



GE Fanuc Automation

Computer Numerical Control Products

Series 16i-TB
Series 18i-TB
Series 160i-TB
Series 180i-TB

Operator's Manual

Warnings, Cautions, and Notes as Used in this Publication

Warning

Warning notices are used in this publication to emphasize that hazardous voltages, currents, temperatures, or other conditions that could cause personal injury exist in this equipment or may be associated with its use.

In situations where inattention could cause either personal injury or damage to equipment, a Warning notice is used.

Caution

Caution notices are used where equipment might be damaged if care is not taken.

Note

Notes merely call attention to information that is especially significant to understanding and operating the equipment.

This document is based on information available at the time of its publication. While efforts have been made to be accurate, the information contained herein does not purport to cover all details or variations in hardware or software, nor to provide for every possible contingency in connection with installation, operation, or maintenance. Features may be described herein which are not present in all hardware and software systems. GE Fanuc Automation assumes no obligation of notice to holders of this document with respect to changes subsequently made.

GE Fanuc Automation makes no representation or warranty, expressed, implied, or statutory with respect to, and assumes no responsibility for the accuracy, completeness, sufficiency, or usefulness of the information contained herein. No warranties of merchantability or fitness for purpose shall apply.

SAFETY PRECAUTIONS

This section describes the safety precautions related to the use of CNC units. It is essential that these precautions be observed by users to ensure the safe operation of machines equipped with a CNC unit (all descriptions in this section assume this configuration). Note that some precautions are related only to specific functions, and thus may not be applicable to certain CNC units.

Users must also observe the safety precautions related to the machine, as described in the relevant manual supplied by the machine tool builder. Before attempting to operate the machine or create a program to control the operation of the machine, the operator must become fully familiar with the contents of this manual and relevant manual supplied by the machine tool builder.

Contents

1. DEFINITION OF WARNING, CAUTION, AND NOTE	s-2
2. GENERAL WARNINGS AND CAUTIONS	s-3
3. WARNINGS AND CAUTIONS RELATED TO PROGRAMMING	s-5
4. WARNINGS AND CAUTIONS RELATED TO HANDLING	s-7
5. WARNINGS RELATED TO DAILY MAINTENANCE	s-9

1

DEFINITION OF WARNING, CAUTION, AND NOTE

This manual includes safety precautions for protecting the user and preventing damage to the machine. Precautions are classified into Warning and Caution according to their bearing on safety. Also, supplementary information is described as a Note. Read the Warning, Caution, and Note thoroughly before attempting to use the machine.

WARNING

Applied when there is a danger of the user being injured or when there is a danger of both the user being injured and the equipment being damaged if the approved procedure is not observed.

CAUTION

Applied when there is a danger of the equipment being damaged, if the approved procedure is not observed.

NOTE

The Note is used to indicate supplementary information other than Warning and Caution.

- **Read this manual carefully, and store it in a safe place.**

2 GENERAL WARNINGS AND CAUTIONS

WARNING

1. Never attempt to machine a workpiece without first checking the operation of the machine. Before starting a production run, ensure that the machine is operating correctly by performing a trial run using, for example, the single block, feedrate override, or machine lock function or by operating the machine with neither a tool nor workpiece mounted. Failure to confirm the correct operation of the machine may result in the machine behaving unexpectedly, possibly causing damage to the workpiece and/or machine itself, or injury to the user.
2. Before operating the machine, thoroughly check the entered data. Operating the machine with incorrectly specified data may result in the machine behaving unexpectedly, possibly causing damage to the workpiece and/or machine itself, or injury to the user.
3. Ensure that the specified feedrate is appropriate for the intended operation. Generally, for each machine, there is a maximum allowable feedrate. The appropriate feedrate varies with the intended operation. Refer to the manual provided with the machine to determine the maximum allowable feedrate. If a machine is run at other than the correct speed, it may behave unexpectedly, possibly causing damage to the workpiece and/or machine itself, or injury to the user.
4. When using a tool compensation function, thoroughly check the direction and amount of compensation. Operating the machine with incorrectly specified data may result in the machine behaving unexpectedly, possibly causing damage to the workpiece and/or machine itself, or injury to the user.
5. The parameters for the CNC and PMC are factory-set. Usually, there is not need to change them. When, however, there is not alternative other than to change a parameter, ensure that you fully understand the function of the parameter before making any change. Failure to set a parameter correctly may result in the machine behaving unexpectedly, possibly causing damage to the workpiece and/or machine itself, or injury to the user.
6. Immediately after switching on the power, do not touch any of the keys on the MDI panel until the position display or alarm screen appears on the CNC unit. Some of the keys on the MDI panel are dedicated to maintenance or other special operations. Pressing any of these keys may place the CNC unit in other than its normal state. Starting the machine in this state may cause it to behave unexpectedly.
7. The operator's manual and programming manual supplied with a CNC unit provide an overall description of the machine's functions, including any optional functions. Note that the optional functions will vary from one machine model to another. Therefore, some functions described in the manuals may not actually be available for a particular model. Check the specification of the machine if in doubt.

WARNING

- 8.** Some functions may have been implemented at the request of the machine-tool builder. When using such functions, refer to the manual supplied by the machine-tool builder for details of their use and any related cautions.

NOTE

Programs, parameters, and macro variables are stored in nonvolatile memory in the CNC unit. Usually, they are retained even if the power is turned off. Such data may be deleted inadvertently, however, or it may prove necessary to delete all data from nonvolatile memory as part of error recovery.

To guard against the occurrence of the above, and assure quick restoration of deleted data, backup all vital data, and keep the backup copy in a safe place.

3

WARNINGS AND CAUTIONS RELATED TO PROGRAMMING

This section covers the major safety precautions related to programming. Before attempting to perform programming, read the supplied operator's manual and programming manual carefully such that you are fully familiar with their contents.

WARNING

1. Coordinate system setting

If a coordinate system is established incorrectly, the machine may behave unexpectedly as a result of the program issuing an otherwise valid move command.

Such an unexpected operation may damage the tool, the machine itself, the workpiece, or cause injury to the user.

2. Positioning by nonlinear interpolation

When performing positioning by nonlinear interpolation (positioning by nonlinear movement between the start and end points), the tool path must be carefully confirmed before performing programming.

Positioning involves rapid traverse. If the tool collides with the workpiece, it may damage the tool, the machine itself, the workpiece, or cause injury to the user.

3. Function involving a rotation axis

When programming polar coordinate interpolation or normal-direction (perpendicular) control, pay careful attention to the speed of the rotation axis. Incorrect programming may result in the rotation axis speed becoming excessively high, such that centrifugal force causes the chuck to lose its grip on the workpiece if the latter is not mounted securely.

Such mishap is likely to damage the tool, the machine itself, the workpiece, or cause injury to the user.

4. Inch/metric conversion

Switching between inch and metric inputs does not convert the measurement units of data such as the workpiece origin offset, parameter, and current position. Before starting the machine, therefore, determine which measurement units are being used. Attempting to perform an operation with invalid data specified may damage the tool, the machine itself, the workpiece, or cause injury to the user.

5. Constant surface speed control

When an axis subject to constant surface speed control approaches the origin of the workpiece coordinate system, the spindle speed may become excessively high. Therefore, it is necessary to specify a maximum allowable speed. Specifying the maximum allowable speed incorrectly may damage the tool, the machine itself, the workpiece, or cause injury to the user.

WARNING**6. Stroke check**

After switching on the power, perform a manual reference position return as required. Stroke check is not possible before manual reference position return is performed. Note that when stroke check is disabled, an alarm is not issued even if a stroke limit is exceeded, possibly damaging the tool, the machine itself, the workpiece, or causing injury to the user.

7. Tool post interference check

A tool post interference check is performed based on the tool data specified during automatic operation. If the tool specification does not match the tool actually being used, the interference check cannot be made correctly, possibly damaging the tool or the machine itself, or causing injury to the user.

After switching on the power, or after selecting a tool post manually, always start automatic operation and specify the tool number of the tool to be used.

8. Absolute/incremental mode

If a program created with absolute values is run in incremental mode, or vice versa, the machine may behave unexpectedly.

9. Plane selection

If an incorrect plane is specified for circular interpolation, helical interpolation, or a canned cycle, the machine may behave unexpectedly. Refer to the descriptions of the respective functions for details.

10. Torque limit skip

Before attempting a torque limit skip, apply the torque limit. If a torque limit skip is specified without the torque limit actually being applied, a move command will be executed without performing a skip.

11. Programmable mirror image

Note that programmed operations vary considerably when a programmable mirror image is enabled.

12. Compensation function

If a command based on the machine coordinate system or a reference position return command is issued in compensation function mode, compensation is temporarily canceled, resulting in the unexpected behavior of the machine.

Before issuing any of the above commands, therefore, always cancel compensation function mode.

4 WARNINGS AND CAUTIONS RELATED TO HANDLING

This section presents safety precautions related to the handling of machine tools. Before attempting to operate your machine, read the supplied operator's manual and programming manual carefully, such that you are fully familiar with their contents.

WARNING

1. Manual operation

When operating the machine manually, determine the current position of the tool and workpiece, and ensure that the movement axis, direction, and feedrate have been specified correctly. Incorrect operation of the machine may damage the tool, the machine itself, the workpiece, or cause injury to the operator.

2. Manual reference position return

After switching on the power, perform manual reference position return as required. If the machine is operated without first performing manual reference position return, it may behave unexpectedly. Stroke check is not possible before manual reference position return is performed. An unexpected operation of the machine may damage the tool, the machine itself, the workpiece, or cause injury to the user.

3. Manual numeric command

When issuing a manual numeric command, determine the current position of the tool and workpiece, and ensure that the movement axis, direction, and command have been specified correctly, and that the entered values are valid.

Attempting to operate the machine with an invalid command specified may damage the tool, the machine itself, the workpiece, or cause injury to the operator.

4. Manual handle feed

In manual handle feed, rotating the handle with a large scale factor, such as 100, applied causes the tool and table to move rapidly. Careless handling may damage the tool and/or machine, or cause injury to the user.

5. Disabled override

If override is disabled (according to the specification in a macro variable) during threading, rigid tapping, or other tapping, the speed cannot be predicted, possibly damaging the tool, the machine itself, the workpiece, or causing injury to the operator.

6. Origin/preset operation

Basically, never attempt an origin/preset operation when the machine is operating under the control of a program. Otherwise, the machine may behave unexpectedly, possibly damaging the tool, the machine itself, the tool, or causing injury to the user.

WARNING**7. Workpiece coordinate system shift**

Manual intervention, machine lock, or mirror imaging may shift the workpiece coordinate system. Before attempting to operate the machine under the control of a program, confirm the coordinate system carefully.

If the machine is operated under the control of a program without making allowances for any shift in the workpiece coordinate system, the machine may behave unexpectedly, possibly damaging the tool, the machine itself, the workpiece, or causing injury to the operator.

8. Software operator's panel and menu switches

Using the software operator's panel and menu switches, in combination with the MDI panel, it is possible to specify operations not supported by the machine operator's panel, such as mode change, override value change, and jog feed commands.

Note, however, that if the MDI panel keys are operated inadvertently, the machine may behave unexpectedly, possibly damaging the tool, the machine itself, the workpiece, or causing injury to the user.

9. Manual intervention

If manual intervention is performed during programmed operation of the machine, the tool path may vary when the machine is restarted. Before restarting the machine after manual intervention, therefore, confirm the settings of the manual absolute switches, parameters, and absolute/incremental command mode.

10. Feed hold, override, and single block

The feed hold, feedrate override, and single block functions can be disabled using custom macro system variable #3004. Be careful when operating the machine in this case.

11. Dry run

Usually, a dry run is used to confirm the operation of the machine. During a dry run, the machine operates at dry run speed, which differs from the corresponding programmed feedrate. Note that the dry run speed may sometimes be higher than the programmed feed rate.

12. Cutter and tool nose radius compensation in MDI mode

Pay careful attention to a tool path specified by a command in MDI mode, because cutter or tool nose radius compensation is not applied. When a command is entered from the MDI to interrupt in automatic operation in cutter or tool nose radius compensation mode, pay particular attention to the tool path when automatic operation is subsequently resumed. Refer to the descriptions of the corresponding functions for details.

13. Program editing

If the machine is stopped, after which the machining program is edited (modification, insertion, or deletion), the machine may behave unexpectedly if machining is resumed under the control of that program. Basically, do not modify, insert, or delete commands from a machining program while it is in use.

5

WARNINGS RELATED TO DAILY MAINTENANCE

WARNING

1. Memory backup battery replacement

Only those personnel who have received approved safety and maintenance training may perform this work.

When replacing the batteries, be careful not to touch the high-voltage circuits (marked  and fitted with an insulating cover).

Touching the uncovered high-voltage circuits presents an extremely dangerous electric shock hazard.

NOTE

The CNC uses batteries to preserve the contents of its memory, because it must retain data such as programs, offsets, and parameters even while external power is not applied.

If the battery voltage drops, a low battery voltage alarm is displayed on the machine operator's panel or CRT screen.

When a low battery voltage alarm is displayed, replace the batteries within a week. Otherwise, the contents of the CNC's memory will be lost.

Refer to the maintenance section of the operator's manual or programming manual for details of the battery replacement procedure.

WARNING**2. Absolute pulse coder battery replacement**

Only those personnel who have received approved safety and maintenance training may perform this work.

When replacing the batteries, be careful not to touch the high-voltage circuits (marked  and fitted with an insulating cover).

Touching the uncovered high-voltage circuits presents an extremely dangerous electric shock hazard.

NOTE

The absolute pulse coder uses batteries to preserve its absolute position.

If the battery voltage drops, a low battery voltage alarm is displayed on the machine operator's panel or CRT screen.

When a low battery voltage alarm is displayed, replace the batteries within a week. Otherwise, the absolute position data held by the pulse coder will be lost.

Refer to the FANUC SERVO MOTOR α series maintenance manual for details of the battery replacement procedure.

WARNING**3. Fuse replacement**

Before replacing a blown fuse, however, it is necessary to locate and remove the cause of the blown fuse.

For this reason, only those personnel who have received approved safety and maintenance training may perform this work.

When replacing a fuse with the cabinet open, be careful not to touch the high-voltage circuits (marked  and fitted with an insulating cover).

Touching an uncovered high-voltage circuit presents an extremely dangerous electric shock hazard.

Table of Contents

SAFETY PRECAUTIONS	s-1
---------------------------------	------------

I. GENERAL

1. GENERAL	3
1.1 GENERAL FLOW OF OPERATION OF CNC MACHINE TOOL	6
1.2 CAUTIONS ON READING THIS MANUAL	8
1.3 CAUTIONS ON VARIOUS KINDS OF DATA	8

II. PROGRAMMING

1. GENERAL	11
1.1 TOOL MOVEMENT ALONG WORKPIECE PARTS FIGURE-INTERPOLATION	12
1.2 FEED-FEED FUNCTION	15
1.3 PART DRAWING AND TOOL MOVEMENT	16
1.3.1 Reference Position (Machine-Specific Position)	16
1.3.2 Coordinate System on Part Drawing and Coordinate System Specified by CNC - Coordinate System	17
1.3.3 How to Indicate Command Dimensions for Moving the Tool - Absolute, Incremental Commands	20
1.4 CUTTING SPEED - SPINDLE SPEED FUNCTION	23
1.5 SELECTION OF TOOL USED FOR VARIOUS MACHINING - TOOL FUNCTION	24
1.6 COMMAND FOR MACHINE OPERATIONS - MISCELLANEOUS FUNCTION	25
1.7 PROGRAM CONFIGURATION	26
1.8 TOOL FIGURE AND TOOL MOTION BY PROGRAM	29
1.9 TOOL MOVEMENT RANGE - STROKE	30
2. CONTROLLED AXES	31
2.1 CONTROLLED AXES	32
2.2 NAMES OF AXES	34
2.3 INCREMENT SYSTEM	35
2.4 MAXIMUM STROKES	36
3. PREPARATORY FUNCTION (G FUNCTION)	37
4. INTERPOLATION FUNCTIONS	42
4.1 POSITIONING (G00)	43
4.2 SINGLE DIRECTION POSITIONING (G60)	45
4.3 LINEAR INTERPOLATION (G01)	51
4.4 CIRCULAR INTERPOLATION (G02, G03)	52
4.5 HELICAL INTERPOLATION (G02, G03)	57
4.6 POLAR COORDINATE INTERPOLATION (G12.1, G13.1)	58
4.7 CYLINDRICAL INTERPOLATION (G07.1)	62
4.8 HYPOTHETICAL AXIS INTERPOLATION (G07)	66
4.9 CONSTANT LEAD THREADING (G32)	68
4.10 VARIABLE-LEAD THREAD CUTTING (G34)	72

4.11	CONTINUOUS THREAD CUTTING	73
4.12	MULTIPLE-THREAD CUTTING	74
4.13	CIRCULAR THREADING (G35, G36)	76
4.14	SKIP FUNCTION (G31)	79
4.15	MULTISTAGE SKIP (G31)	81
4.16	TORQUE LIMIT SKIP (G31 P99)	82
5.	FEED FUNCTIONS	84
5.1	GENERAL	85
5.2	RAPID TRAVERSE	87
5.3	CUTTING FEED	88
5.4	DWELL (G04)	91
6.	REFERENCE POSITION	92
6.1	REFERENCE POSITION RETURN	93
6.2	FLOATING REFERENCE POSITION RETURN (G30.1)	96
7.	COORDINATE SYSTEM	97
7.1	MACHINE COORDINATE SYSTEM	98
7.2	WORKPIECE COORDINATE SYSTEM	99
7.2.1	Setting a Workpiece Coordinate System	99
7.2.2	Selecting a Workpiece Coordinate System	101
7.2.3	Changing Workpiece Coordinate System	102
7.2.4	Workpiece Coordinate System Preset (G92.1)	104
7.2.5	Workpiece Coordinate System Shift	106
7.3	LOCAL COORDINATE SYSTEM	107
7.4	PLANE SELECTION	109
8.	COORDINATE VALUE AND DIMENSION	110
8.1	ABSOLUTE AND INCREMENTAL PROGRAMMING (G90, G91)	111
8.2	INCH/METRIC CONVERSION (G20, G21)	112
8.3	DECIMAL POINT PROGRAMMING	113
8.4	DIAMETER AND RADIUS PROGRAMMING	114
9.	SPINDLE SPEED FUNCTION	115
9.1	SPECIFYING THE SPINDLE SPEED WITH A CODE	116
9.2	SPECIFYING THE SPINDLE SPEED VALUE DIRECTLY (S5-DIGIT COMMAND)	116
9.3	CONSTANT SURFACE SPEED CONTROL (G96, G97)	116
9.4	SPINDLE SPEED FLUCTUATION DETECTION FUNCTION (G25, G26)	120
9.5	SPINDLE POSITIONING FUNCTION	123
9.5.1	Spindle Orientation	123
9.5.2	Spindle Positioning	123
9.5.3	Canceling Spindle Positioning	125
10.	TOOL FUNCTION (T FUNCTION)	126
10.1	TOOL SELECTION	127

10.2	TOOL LIFE MANAGEMENT	128
10.2.1	Program of Tool Life Data	128
10.2.2	Counting a Tool Life	131
10.2.3	Specifying a Tool Group in a Machining Program	132
11.	AUXILIARY FUNCTION	133
11.1	AUXILIARY FUNCTION (M FUNCTION)	134
11.2	MULTIPLE M COMMANDS IN A SINGLE BLOCK	135
11.3	M CODE GROUP CHECK FUNCTION	136
11.4	THE SECOND AUXILIARY FUNCTIONS (B CODES)	137
12.	PROGRAM CONFIGURATION	138
12.1	PROGRAM COMPONENTS OTHER THAN PROGRAM SECTIONS	140
12.2	PROGRAM SECTION CONFIGURATION	143
12.3	SUBPROGRAM (M98, M99)	149
12.4	8-DIGIT PROGRAM NUMBER	152
13.	FUNCTIONS TO SIMPLIFY PROGRAMMING	155
13.1	CANNED CYCLE (G90, G92, G94)	156
13.1.1	Outer Diameter / Internal Diameter Cutting Cycle (G90)	156
13.1.2	Thread Cutting Cycle (G92)	158
13.1.3	End Face Turning Cycle (G94)	161
13.1.4	How to Use Canned Cycles (G90, G92, G94)	164
13.2	MULTIPLE REPETITIVE CYCLE (G70-G76)	166
13.2.1	Stock Removal in Turning (G71)	166
13.2.2	Stock Removal in Facing (G72)	170
13.2.3	Pattern Repeating (G73)	171
13.2.4	Finishing Cycle (G70)	172
13.2.5	End Face Peck Drilling Cycle (G74)	175
13.2.6	Outer Diameter / Internal Diameter Drilling Cycle (G75)	176
13.2.7	Multiple Thread Cutting Cycle (G76)	177
13.2.8	Notes on Multiple Repetitive Cycle (G70-G76)	181
13.3	CANNED CYCLE FOR DRILLING (G80-G89)	182
13.3.1	Front Drilling Cycle (G83) / Side Drilling Cycle (G87)	186
13.3.2	Front Tapping Cycle (G84) / Side Tapping Cycle (G88)	189
13.3.3	Front Boring Cycle (G85) / Side Boring Cycle (G89)	191
13.3.4	Canned Cycle for Drilling Cancel (G80)	192
13.3.5	Precautions to be Taken by Operator	193
13.4	CANNED GRINDING CYCLE (FOR GRINDING MACHINE)	194
13.4.1	Traverse Grinding Cycle (G71)	194
13.4.2	Traverse Direct Fixed-dimension Grinding Cycle (G72)	195
13.4.3	Oscillation Grinding Cycle (G73)	196
13.4.4	Oscillation Direct Fixed-Dimension Grinding Cycle	197
13.5	CHAMFERING AND CORNER R	198
13.6	MIRROR IMAGE FOR DOUBLE TURRET (G68, G69)	201
13.7	DIRECT DRAWING DIMENSIONS PROGRAMMING	202
13.8	RIGID TAPPING	207
13.8.1	Front Face Rigid Tapping Cycle (G84) / Side Face Rigid Tapping Cycle (G88)	208
13.9	THREE-DIMENSIONAL COORDINATE CONVERSION (G68.1, G69.1)	211

14.COMPENSATION FUNCTION	219
14.1 TOOL OFFSET	220
14.1.1 Tool Geometry Offset and Tool Wear Offset	220
14.1.2 T Code for Tool Offset	221
14.1.3 Tool Selection	221
14.1.4 Offset Number	221
14.1.5 Offset	222
14.1.6 G53, G28, G30, and G30.1 Commands When Tool Position Offset is Applied	225
14.2 OVERVIEW OF TOOL NOSE RADIUS COMPENSATION	229
14.2.1 Imaginary Tool Nose	229
14.2.2 Direction of Imaginary Tool Nose	231
14.2.3 Offset Number and Offset Value	232
14.2.4 Work Position and Move Command	234
14.2.5 Notes on Tool Nose Radius Compensation	239
14.3 DETAILS OF TOOL NOSE RADIUS COMPENSATION	242
14.3.1 General	242
14.3.2 Tool Movement in Start-up	244
14.3.3 Tool Movement in Offset Mode	246
14.3.4 Tool Movement in Offset Mode Cancel	259
14.3.5 Interference Check	262
14.3.6 Overcutting by Tool Nose Radius Compensation	267
14.3.7 Correction in Chamfering and Corner Arcs	268
14.3.8 Input Command from MDI	270
14.3.9 General Precautions for Offset Operations	271
14.3.10 G53, G28, G30, and G30.1 Commands in Tool-tip Radius Compensation Mode	272
14.4 CORNER CIRCULAR INTERPOLATION FUNCTION (G39)	281
14.5 TOOL COMPENSATION VALUES, NUMBER OF COMPENSATION VALUES, AND ENTERING VALUES FROM THE PROGRAM (G10)	283
14.5.1 Tool Compensation and Number of Tool Compensation	283
14.5.2 Changing of Tool Offset Value (Programmable Data Input) (G10)	285
14.6 AUTOMATIC TOOL OFFSET (G36, G37)	286
14.7 COORDINATE ROTATION (G68.1, G69.1)	289
15.CUSTOM MACRO	293
15.1 VARIABLES	294
15.2 SYSTEM VARIABLES	298
15.3 ARITHMETIC AND LOGIC OPERATION	305
15.4 MACRO STATEMENTS AND NC STATEMENTS	310
15.5 BRANCH AND REPETITION	311
15.5.1 Unconditional Branch (GOTO Statement)	311
15.5.2 Conditional Branch (IF Statement)	312
15.5.3 Repetition (While Statement)	313
15.6 MACRO CALL	316
15.6.1 Simple Call (G65)	317
15.6.2 Modal Call (G66)	321
15.6.3 Macro Call Using G Code	323
15.6.4 Macro Call Using an M Code	324
15.6.5 Subprogram Call Using an M Code	325
15.6.6 Subprogram Calls Using a T Code	326
15.6.7 Sample Program	327
15.7 PROCESSING MACRO STATEMENTS	329
15.8 REGISTERING CUSTOM MACRO PROGRAMS	331

15.9	LIMITATIONS	332
15.10	EXTERNAL OUTPUT COMMANDS	333
15.11	INTERRUPTION TYPE CUSTOM MACRO	337
15.11.1	Specification Method	338
15.11.2	Details of Functions	339
16.	PROGRAMMABLE PARAMETER ENTRY (G10)	346
17.	MEMORY OPERATION BY SERIES 15 TAPE FORMAT	349
17.1	ADDRESSES AND SPECIFIABLE VALUE RANGE FOR SERIES 15 TAPE FORMAT	350
17.2	EQUAL-LEAD THREADING	351
17.3	SUBPROGRAM CALLING	352
17.4	CANNED CYCLE	353
17.5	MULTIPLE REPETITIVE CANNED TURNING CYCLE	354
17.6	CANNED DRILLING CYCLE FORMATS	356
18.	FUNCTIONS FOR HIGH SPEED CUTTING	360
18.1	HIGH SPEED CYCLE CUTTING	361
18.2	DISTRIBUTION PROCESSING TERMINATION MONITORING FUNCTION FOR THE HIGH-SPEED MACHINING COMMAND (G05)	363
18.3	ADVANCE PREVIEW CONTROL (G08)	364
19.	AXIS CONTROL FUNCTION	371
19.1	POLYGONAL TURNING	372
19.2	ROTARY AXIS ROLL-OVER	377
19.2.1	Rotary Axis Roll-over	377
19.2.2	Rotary Axis Control	378
19.3	SIMPLE SYNCHRONIZATION CONTROL	379
19.4	SYNCHRONIZATION CONTROL	381
19.5	B-AXIS CONTROL (G100, G101, G102, G103, G110)	382
19.6	ANGULAR AXIS CONTROL / ARBITRARY ANGULAR AXIS CONTROL	392
19.7	TOOL WITHDRAWAL AND RETURN (G10.6)	394
20.	TWO-PATH CONTROL FUNCTION	397
20.1	GENERAL	398
20.2	WAITING FOR TOOL POSTS	400
20.3	TOOL POST INTERFACE CHECK	402
20.3.1	General	402
20.3.2	Data Setting for the Tool Post Interference Check Function	402
20.3.3	Setting and Display of Interference Forbidden Areas for Tool Post Interference Checking	406
20.3.4	Conditions for Making a Tool Post Interference Check	407
20.3.5	Execution of Tool Post Interference Checking	408
20.3.6	Example of Making a Tool Post Interference Check	410
20.4	BALANCE CUT (G68, G69)	412
20.5	MEMORY COMMON TO TOOL POSTS	414
20.6	SPINDLE CONTROL IN TWO-PATH CONTROL	415
20.7	SYNCHRONIZATION CONTROL AND COMPOSITE CONTROL	417

20.8	COPYING A PROGRAM BETWEEN TWO PATHS	419
------	---	-----

21. PATTERN DATA INPUT FUNCTION 420

21.1	DISPLAYING THE PATTERN MENU	421
21.2	PATTERN DATA DISPLAY	425
21.3	CHARACTERS AND CODES TO BE USED FOR THE PATTERN DATA INPUT FUNCTION	429

III. OPERATION

1. GENERAL 433





1.1	MANUAL OPERATION	434
1.2	TOOL MOVEMENT BY PROGRAMMING – AUTOMATIC OPERATION	436
1.3	AUTOMATIC OPERATION	437
1.4	TESTING A PROGRAM	439
1.4.1	Check by Running the Machine	439
1.4.2	How to View the Position Display Change without Running the Machine	440
1.5	EDITING A PART PROGRAM	441
1.6	DISPLAYING AND SETTING DATA	442
1.7	DISPLAY	445
1.7.1	Program Display	445
1.7.2	Current Position Display	446
1.7.3	Alarm Display	446
1.7.4	Parts Count Display, Run Time Display	447
1.7.5	Graphic Display (See Section III-12)	448
1.8	DATA OUTPUT	449



2. OPERATIONAL DEVICES 450

2.1	SETTING AND DISPLAY UNITS	451
2.1.1	7.2"/8.4" LCD-mounted Type CNC Control Unit	452
2.1.2	9.5"/10.4" LCD-mounted Type CNC Control Unit	452
2.1.3	Stand-alone Type Small MDI Unit	453
2.1.4	Stand-alone Type Standard MDI Unit	454
2.1.5	Stand-alone Type 61 Full Key MDI Unit	455
2.2	EXPLANATION OF THE KEYBOARD	456
2.3	FUNCTION KEYS AND SOFT KEYS	458
2.3.1	General Screen Operations	458
2.3.2	Function Keys	459
2.3.3	Soft Keys	460
2.3.4	Key Input and Input Buffer	476
2.3.5	Warning Messages	477
2.3.6	Soft Key Configuration	478
2.4	EXTERNAL I/O DEVICES	479
2.4.1	FANUC Handy File	481
2.5	POWER ON/OFF	482
2.5.1	Turning on the Power	482
2.5.2	Screen Displayed at Power-on	483
2.5.3	Power Disconnection	484

3. MANUAL OPERATION	485
3.1 MANUAL REFERENCE POSITION RETURN	486
3.2 JOG FEED	488
3.3 INCREMENTAL FEED	490
3.4 MANUAL HANDLE FEED	491
3.5 MANUAL ABSOLUTE ON AND OFF	494
3.6 MANUAL LINEAR/CIRCULAR INTERPOLATION	499
3.7 MANUAL NUMERIC COMMAND	504
4. AUTOMATIC OPERATION	512
4.1 MEMORY OPERATION	513
4.2 MDI OPERATION	516
4.3 PROGRAM RESTART	520
4.4 SCHEDULING FUNCTION	528
4.5 SUBPROGRAM CALL FUNCTION (M198)	533
4.6 MANUAL HANDLE INTERRUPTION	535
4.7 MIRROR IMAGE	538
4.8 MANUAL INTERVENTION AND RETURN	540
4.9 DNC OPERATION	542
4.10 DNC OPERATION WITH MEMORY CARD	545
4.10.1 Specification	545
4.10.2 Operations	546
4.10.2.1 DNC operation	546
4.10.2.2 Subprogram call (M198)	547
4.10.3 Limitation and Notes	548
4.10.4 Parameter	548
4.10.5 Connecting PCMCIA Card Attachment	549
4.10.5.1 Specification number	549
4.10.5.2 Assembling	549
4.10.6 Recommended Memory Card	551
5. TEST OPERATION	552
5.1 MACHINE LOCK AND AUXILIARY FUNCTION LOCK	553
5.2 FEEDRATE OVERRIDE	555
5.3 RAPID TRAVERSE OVERRIDE	556
5.4 DRY RUN	557
5.5 SINGLE BLOCK	558
6. SAFETY FUNCTIONS	562
6.1 EMERGENCY STOP	563
6.2 OVERTRAVEL	564
6.3 STORED STROKE CHECK	565
6.4 CHUCK AND TAILSTOCK BARRIERS	569
6.5 STROKE LIMIT CHECK PRIOR TO PERFORMING MOVEMENT	576

7. ALARM AND SELF-DIAGNOSIS FUNCTIONS	579
7.1 ALARM DISPLAY	580
7.2 ALARM HISTORY DISPLAY	582
7.3 CHECKING BY SELF-DIAGNOSTIC SCREEN	583
8. DATA INPUT/OUTPUT	586
8.1 FILES	587
8.2 FILE SEARCH	589
8.3 FILE DELETION	591
8.4 PROGRAM INPUT/OUTPUT	592
8.4.1 Inputting a Program	592
8.4.2 Outputting a Program	595
8.5 OFFSET DATA INPUT AND OUTPUT	597
8.5.1 Inputting Offset Data	597
8.5.2 Outputting Offset Data	598
8.6 INPUTTING AND OUTPUTTING PARAMETERS AND PITCH ERROR COMPENSATION DATA	599
8.6.1 Inputting Parameters	599
8.6.2 Outputting Parameters	600
8.6.3 Inputting Pitch Error Compensation Data	601
8.6.4 Outputting Pitch Error Compensation Data	602
8.7 INPUTTING / OUTPUTTING CUSTOM MACRO COMMON VARIABLES	603
8.7.1 Inputting Custom Macro Common Variables	603
8.7.2 Outputting Custom Macro Common Variable	604
8.8 DISPLAYING DIRECTORY OF FLOPPY DISK	605
8.8.1 Displaying the Directory	606
8.8.2 Reading Files	609
8.8.3 Outputting Programs	610
8.8.4 Deleting Files	611
8.9 OUTPUTTING A PROGRAM LIST FOR A SPECIFIED GROUP	613
8.10 DATA INPUT/OUTPUT ON THE ALL IO SCREEN	614
8.10.1 Setting Input/Output-Related Parameters	615
8.10.2 Inputting and Outputting Programs	616
8.10.3 Inputting and Outputting Parameters	620
8.10.4 Inputting and Outputting Offset Data	622
8.10.5 Outputting Custom Macro Common Variables	624
8.10.6 Inputting and Outputting Floppy Files	625
8.10.7 Memory Card Input/Output	630
8.11 DATA INPUT/OUTPUT USING A MEMORY CARD	639
9. EDITING PROGRAMS	651
9.1 INSERTING, ALTERING AND DELETING A WORD	652
9.1.1 Word Search	653
9.1.2 Heading a Program	655
9.1.3 Inserting a Word	656
9.1.4 Altering a Word	657
9.1.5 Deleting a Word	658
9.2 DELETING BLOCKS	659
9.2.1 Deleting a Block	659
9.2.2 Deleting Multiple Blocks	660
9.3 PROGRAM NUMBER SEARCH	662

9.4	SEQUENCE NUMBER SEARCH	663
9.5	DELETING PROGRAMS	665
9.5.1	Deleting One Program	665
9.5.2	Deleting All Programs	665
9.5.3	Deleting More Than One Program by Specifying a Range	666
9.6	EXTENDED PART PROGRAM EDITING FUNCTION	667
9.6.1	Copying an Entire Program	668
9.6.2	Copying Part of a Program	669
9.6.3	Moving Part of a Program	670
9.6.4	Merging a Program	671
9.6.5	Supplementary Explanation for Copying, Moving and Merging	672
9.6.6	Replacement of Words and Addresses	674
9.7	EDITING OF CUSTOM MACROS	676
9.8	BACKGROUND EDITING	677
9.9	PASSWORD FUNCTION	678
9.10	COPYING A PROGRAM BETWEEN TWO PATHS	680
10.	CREATING PROGRAMS	684
10.1	CREATING PROGRAMS USING THE MDI PANEL	685
10.2	AUTOMATIC INSERTION OF SEQUENCE NUMBERS	686
10.3	CREATING PROGRAMS IN TEACH IN MODE (PLAYBACK)	688
10.4	CONVERSATIONAL PROGRAMMING WITH GRAPHIC FUNCTION	691
11.	SETTING AND DISPLAYING DATA	695
11.1	SCREENS DISPLAYED BY FUNCTION KEY 	703
11.1.1	Position Display in the Workpiece Coordinate System	704
11.1.2	Position Display in the Relative Coordinate System	706
11.1.3	Overall Position Display	709
11.1.4	Presetting the Workpiece Coordinate System	711
11.1.5	Actual Feedrate Display	712
11.1.6	Display of Run Time and Parts Count	714
11.1.7	Setting the Floating Reference Position	715
11.1.8	Operating Monitor Display	716
11.2	SCREENS DISPLAYED BY FUNCTION KEY  (IN MEMORY MODE OR MDI MODE)	718
11.2.1	Program Contents Display	719
11.2.2	Current Block Display Screen	720
11.2.3	Next Block Display Screen	721
11.2.4	Program Check Screen	722
11.2.5	Program Screen for MDI Operation	725
11.2.6	Stamping the Machining Time	726
11.2.7	Displaying the B-axis Operation State	734
11.3	SCREENS DISPLAYED BY FUNCTION KEY  (IN THE EDIT MODE)	735
11.3.1	Displaying Memory Used and a List of Programs	736
11.3.2	Two-path Simultaneous Editing on the Program Screen	739
11.3.3	Displaying a Program List for a Specified Group	742
11.4	SCREENS DISPLAYED BY FUNCTION KEY 	745

11.4.1	Setting and Displaying the Tool Offset Value	746
11.4.2	Direct Input of Tool Offset Value	749
11.4.3	Direct Input of tool offset measured B	751
11.4.4	Counter Input of Offset value	753
11.4.5	Setting the Workpiece Coordinate System Shifting Amount	754
11.4.6	Y Axis Offset	756
11.4.7	Displaying and Entering Setting Data	759
11.4.8	Sequence Number Comparison and Stop	761
11.4.9	Displaying and Setting Run Time,Parts Count, and Time	763
11.4.10	Displaying and Setting the Workpiece Origin Offset Value	765
11.4.11	Direct Input of Measured Workpiece Origin Offsets	766
11.4.12	Displaying and Setting Custom Macro Common Variables	768
11.4.13	Displaying and Setting the Software Operator's Panel	769
11.4.14	Displaying and Setting Tool Life Management Data	771
11.4.15	Setting and Displaying B-axis Tool Compensation	774
11.5	SCREENS DISPLAYED BY FUNCTION KEY 	776
11.5.1	Displaying and Setting Parameters	777
11.5.2	Displaying and Setting Pitch Error Compensation Data	779
11.6	DISPLAYING THE PROGRAM NUMBER, SEQUENCE NUMBER, AND STATUS, AND WARNING MESSAGES FOR DATA SETTING OR INPUT/OUTPUT OPERATION	782
11.6.1	Displaying the Program Number and Sequence Number	782
11.6.2	Displaying the Status and Warning for Data Setting or Input/Output Operation	783
11.7	SCREENS DISPLAYED BY FUNCTION KEY 	785
11.7.1	External Operator Message History Display	785
11.8	CLEARING THE SCREEN	787
11.8.1	Erase CRT Screen Display	787
11.8.2	Automatic Erase CNC Screen Display	788
12	GRAPHICS FUNCTION	789
12.1	GRAPHICS DISPLAY	790
13	HELP FUNCTION	796
14	SCREEN HARDCOPY	801
IV. MAINTENANCE		
1	METHOD OF REPLACING BATTERY	807
1.1	REPLACING BATTERY FOR LCD-MOUNTED TYPE <i>i</i> SERIES	808
1.2	REPLACING THE BATTERY FOR STAND-ALONE TYPE <i>i</i> SERIES	811
1.3	BATTERY IN THE PANEL <i>i</i> (3 VDC)	814
1.4	BATTERY FOR SEPARATE ABSOLUTE PULSE CODERS (6 VDC)	816
1.5	BATTERY FOR BUILT-IN ABSOLUTE PULSE CODERS (DC6V)	817

APPENDIX

A. TAPE CODE LIST	825
B. LIST OF FUNCTIONS AND TAPE FORMAT	828
C. RANGE OF COMMAND VALUE	832
D. NOMOGRAPHS	835
D.1 INCORRECT THREADED LENGTH	836
D.2 SIMPLE CALCULATION OF INCORRECT THREAD LENGTH	838
D.3 TOOL PATH AT CORNER	840
D.4 RADIUS DIRECTION ERROR AT CIRCLE CUTTING	843
E. STATUS WHEN TURNING POWER ON, WHEN CLEAR AND WHEN RESET	844
F. CHARACTER-TO-CODES CORRESPONDENCE TABLE	846
G. ALARM LIST	847

I. GENERAL

1 GENERAL

This manual consists of the following parts:

About this manual

I. GENERAL

Describes chapter organization, applicable models, related manuals, and notes for reading this manual.

II. PROGRAMMING

Describes each function: Format used to program functions in the NC language, characteristics, and restrictions. When a program is created through conversational automatic programming function, refer to the manual for the conversational automatic programming function (Table1).

III. OPERATION

Describes the manual operation and automatic operation of a machine, procedures for inputting and outputting data, and procedures for editing a program.

IV. MAINTENANCE

Describes procedures for replacing batteries.

APPENDIX

Lists tape codes, valid data ranges, and error codes.

Some functions described in this manual may not be applied to some products. For detail, refer to the DESCRIPTIONS manual (B-63522EN).

This manual does not describe parameters in detail. For details on parameters mentioned in this manual, refer to the manual for parameters (B-63530EN).

This manual describes all optional functions. Look up the options incorporated into your system in the manual written by the machine tool builder.

Applicable models

The models covered by this manual, and their abbreviations are:

Product name	Abbreviations	
FANUC Series 16i-TB	16i-TB	Series 16i
FANUC Series 18i-TB	18i-TB	Series 18i
FANUC Series 160i-TB	160i-TB	Series 160i
FANUC Series 180i-TB	180i-TB	Series 180i

Special symbols

This manual uses the following symbols:

- **IP** Indicates a combination of axes such as X__ Y__ Z (used in PROGRAMMING.).
- ; Indicates the end of a block. It actually corresponds to the ISO code LF or EIA code CR.

Related manuals of Series 16i/18i/21i/160i/180i/210i-MODEL B

The following table lists the manuals related to Series 16i, Series 18i, Series 21i, Series 160i, Series 180i, Series 210i-MODEL B. This manual is indicated by an asterisk(*).

Manual name	Specification number	
DESCRIPTIONS	B-63522EN	
CONNECTION MANUAL (HARDWARE)	B-63523EN	
CONNECTION MANUAL (FUNCTION)	B-63523EN-1	
OPERATORS MANUAL (16i/18i/160i/180i-TB)	B-63524EN	*
OPERATOR'S MANUAL (16i/18i/160i/180i-MB)	B-63534EN	
OPERATOR'S MANUAL (21i/210i-TB)	B-63604EN	
OPERATOR'S MANUAL (21i/210i-MB)	B-63614EN	
MAINTENANCE MANUAL	B-63625EN	
PARAMETER MANUAL (16i/18i/160i/180i-MODEL B)	B-63530EN	
PARAMETER MANUAL (21i/210i-MODEL B)	B-63610EN	
PROGRAMMING MANUAL		
Macro Compiler/Macro Executor PROGRAMMING MANUAL	B-61803E-1	
FAPT MACRO COMPILER (For Personal Computer) PROGRAMMING MANUAL	B-66102E	
C Language Executor PROGRAMMING MANUAL	B-62443EN-3	
CAP (T series)		
FANUC Super CAPi T OPERATORS MANUAL	B-63284EN	
FANUC Symbol CAPi T OPERATOR'S MANUAL	B-63304EN	
MANUAL GUIDE For Lathe PROGRAMMING MANUAL	B-63343EN	
MANUAL GUIDE For Lathe OPERATOR'S MANUAL	B-63344EN	
CAP (M series)		
FANUC Super CAPi M OPERATOR'S MANUAL	B-63294EN	
MANUAL GUIDE For Milling PROGRAMMING MANUAL	B-63423EN	
MANUAL GUIDE For Milling OPERATOR'S MANUAL	B-63424EN	

Manual name	Specification number	
PMC		
PMC Ladder Language PROGRAMMING MANUAL	B-61863E	
PMC C Language PROGRAMMING MANUAL	B-61863E-1	
Network		
FANUC I/O Link-II CONNECTION MANUAL	B-62714EN	
Profibus-DP Board OPERATOR'S MANUAL	B-62924EN	
DeviceNet Board OPERATOR'S MANUAL	B-63404EN	
Ethernet Board/DATA SERVER Board OPERATOR'S MANUAL	B-63354EN	

Related manuals of SERVO MOTOR α series

The following table lists the manuals related to SERVO MOTOR α series

Manual name	Specification number
AC SERVO MOTOR α series DESCRIPTIONS	B-65142E
AC SERVO MOTOR α series PARAMETER MANUAL	B-65150E
AC SPINDLE MOTOR α series DESCRIPTIONS	B-65152E
AC SPINDLE MOTOR α series PARAMETER MANUAL	B-65160E
SERVO AMPLIFIER α series DESCRIPTIONS	B-65162E
SERVO MOTOR α series MAINTENANCE MANUAL	B-65165E

1.1 GENERAL FLOW OF OPERATION OF CNC MACHINE TOOL

When machining the part using the CNC machine tool, first prepare the program, then operate the CNC machine by using the program.

- 1) First, prepare the program from a part drawing to operate the CNC machine tool.
How to prepare the program is described in the Chapter II. PROGRAMMING.
- 2) The program is to be read into the CNC system. Then, mount the workpieces and tools on the machine, and operate the tools according to the programming. Finally, execute the machining actually.
How to operate the CNC system is described in the Chapter III. OPERATION.

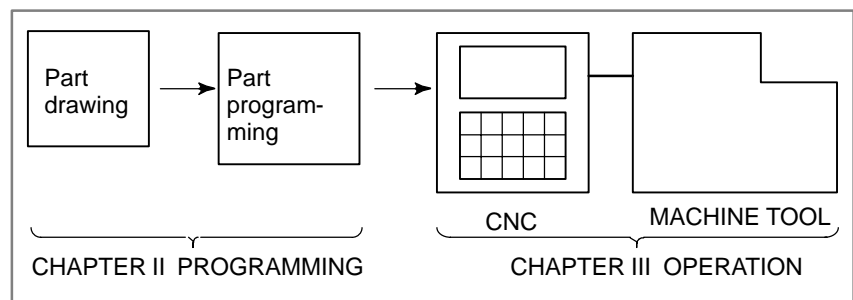

Before the actual programming, make the machining plan for how to machine the part.

Machining plan

1. Determination of workpieces machining range
2. Method of mounting workpieces on the machine tool
3. Machining sequence in every cutting process
4. Cutting tools and cutting conditions

Decide the cutting method in every cutting process.

Cutting process Cutting procedure	1	2	3
	End face cutting	Outer diameter cutting	Grooving
1. Cutting method : Rough Semi Finish			
2. Cutting tools			
3. Cutting conditions : Feedrate Cutting depth			
4. Tool path			

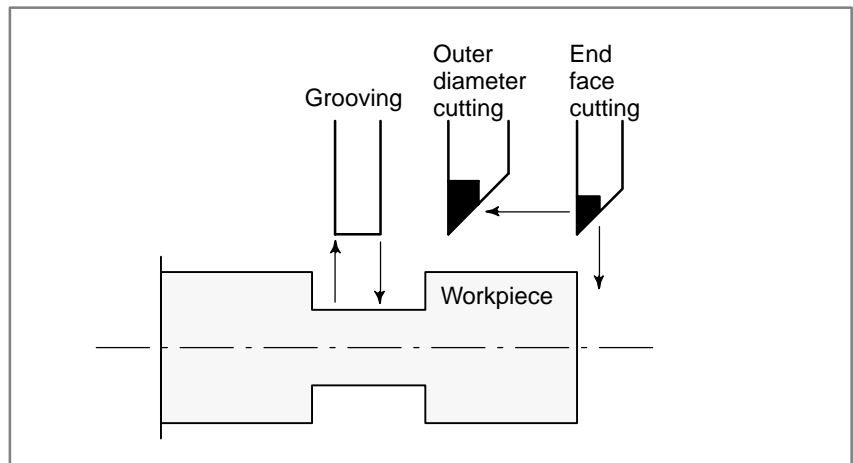

Prepare the program of the tool path and cutting condition according to the workpiece figure, for each cutting.

1.2 CAUTIONS ON READING THIS MANUAL

CAUTION

- 1 The function of an CNC machine tool system depends not only on the CNC, but on the combination of the machine tool, its magnetic cabinet, the servo system, the CNC, the operator's panels, etc. It is too difficult to describe the function, programming, and operation relating to all combinations. This manual generally describes these from the stand-point of the CNC. So, for details on a particular CNC machine tool, refer to the manual issued by the machine tool builder, which should take precedence over this manual.
- 2 Headings are placed in the left margin so that the reader can easily access necessary information. When locating the necessary information, the reader can save time by searching through these headings.
- 3 This manual describes as many reasonable variations in equipment usage as possible. It cannot address every combination of features, options and commands that should not be attempted.
If a particular combination of operations is not described, it should not be attempted.

1.3 CAUTIONS ON VARIOUS KINDS OF DATA

CAUTION

Machining programs, parameters, variables, etc. are stored in the CNC unit internal non-volatile memory. In general, these contents are not lost by the switching ON/OFF of the power. However, it is possible that a state can occur where precious data stored in the non-volatile memory has to be deleted, because of deletions from a maloperation, or by a failure restoration. In order to restore rapidly when this kind of mishap occurs, it is recommended that you create a copy of the various kinds of data beforehand.

II. PROGRAMMING

1

GENERAL



1.1 TOOL MOVEMENT ALONG WORKPIECE PARTS FIGURE- INTERPOLATION

Explanations

- Tool movement along a straight line

The tool moves along straight lines and arcs constituting the workpiece parts figure (See II-4).

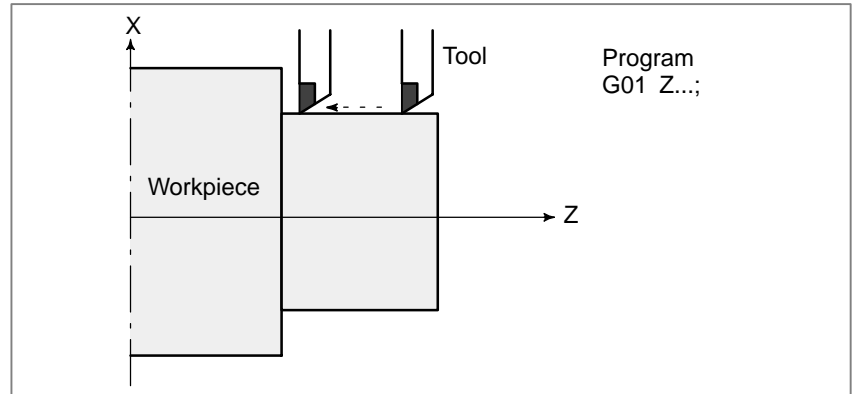

Fig.1.1 (a) Tool movement along the straight line which is parallel to Z-axis

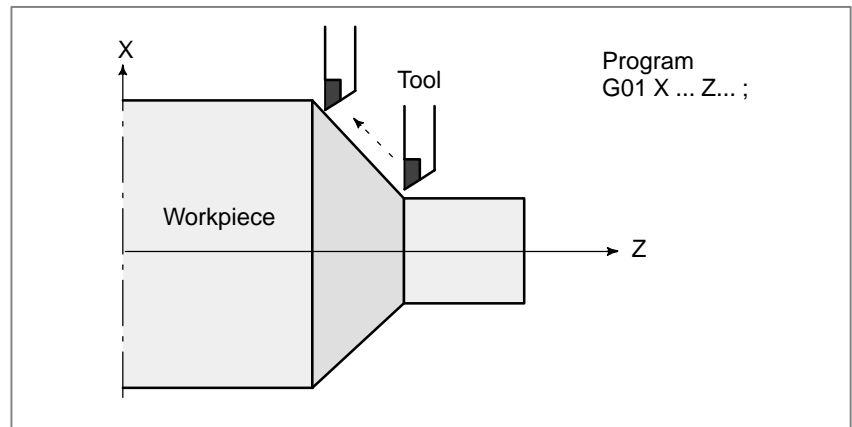

Fig.1.1 (b) Tool movement along the taper line

- Tool movement along an arc

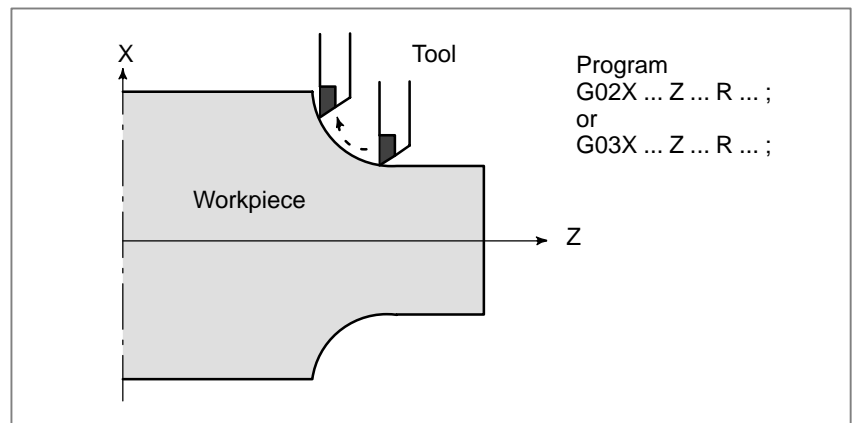

Fig. 1.1 (c) Tool movement along an arc

The term interpolation refers to an operation in which the tool moves along a straight line or arc in the way described above.

Symbols of the programmed commands G01, G02, ... are called the preparatory function and specify the type of interpolation conducted in the control unit.

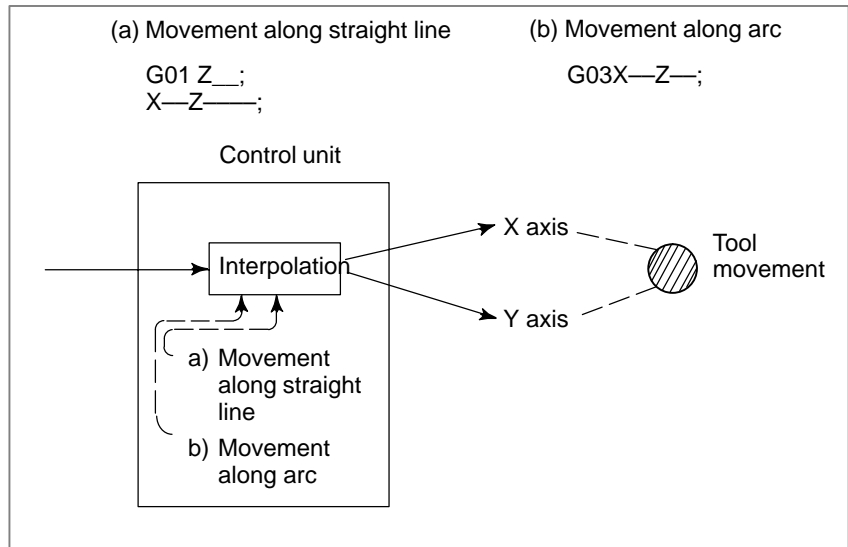

Fig. 1.1 (d) Interpolation function

NOTE

Some machines move tables instead of tools but this manual assumes that tools are moved against workpieces.

• **Thread cutting**

Threads can be cut by moving the tool in synchronization with spindle rotation. In a program, specify the thread cutting function by G32.

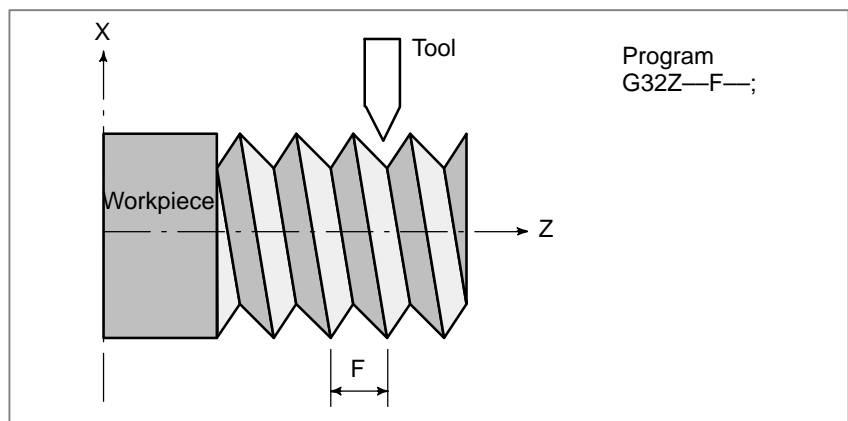

Fig. 1.1 (e) Straight thread cutting

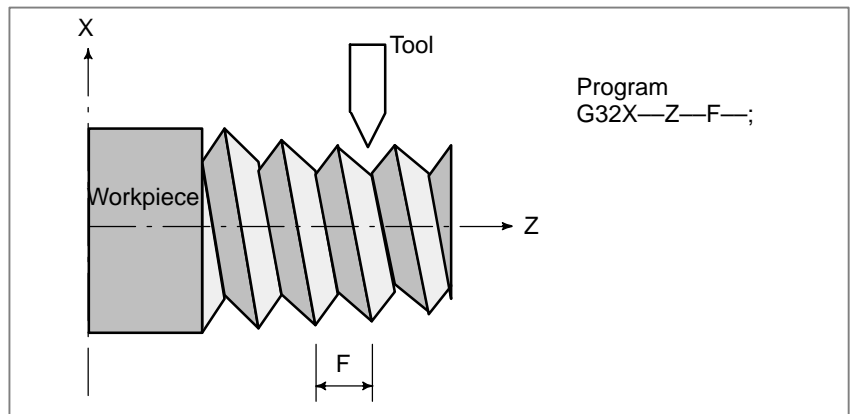

Fig. 1.1 (f) Taper thread cutting

1.2 FEED- FEED FUNCTION

Movement of the tool at a specified speed for cutting a workpiece is called the feed.

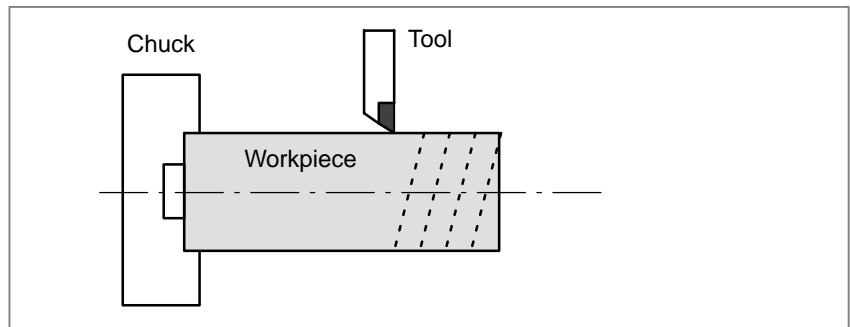

Fig. 1.2 (a) Feed function

Feedrates can be specified by using actual numerics.

For example, the following command can be used to feed the tool 2 mm while the workpiece makes one turn :

F2.0

The function of deciding the feed rate is called the feed function (See II-5).

1.3 PART DRAWING AND TOOL MOVEMENT

1.3.1 Reference Position (Machine-Specific Position)

A CNC machine tool is provided with a fixed position. Normally, tool change and programming of absolute zero point as described later are performed at this position. This position is called the reference position.

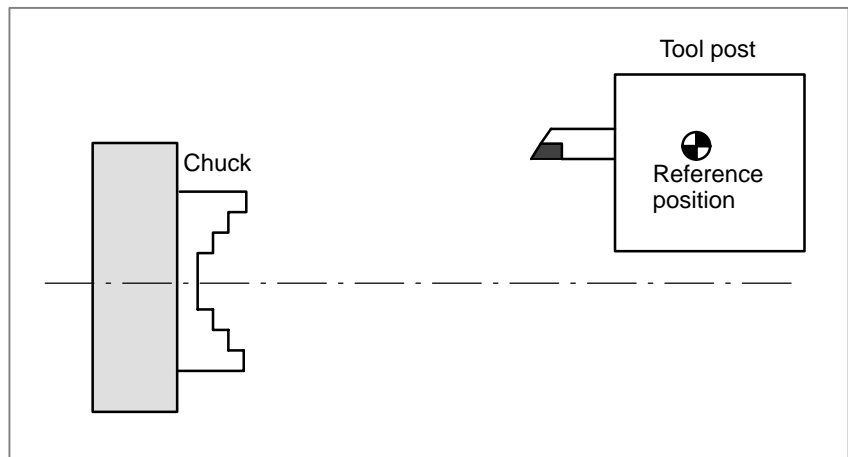

Fig. 1.3.1 (a) Reference position

Explanations

The tool can be moved to the reference position in two ways:

1. Manual reference position return (See III-3.1)
Reference position return is performed by manual button operation.
2. Automatic reference position return (See II-6)
In general, manual reference position return is performed first after the power is turned on. In order to move the tool to the reference position for tool change thereafter, the function of automatic reference position return is used.

1.3.2 Coordinate System on Part Drawing and Coordinate System Specified by CNC – Coordinate System

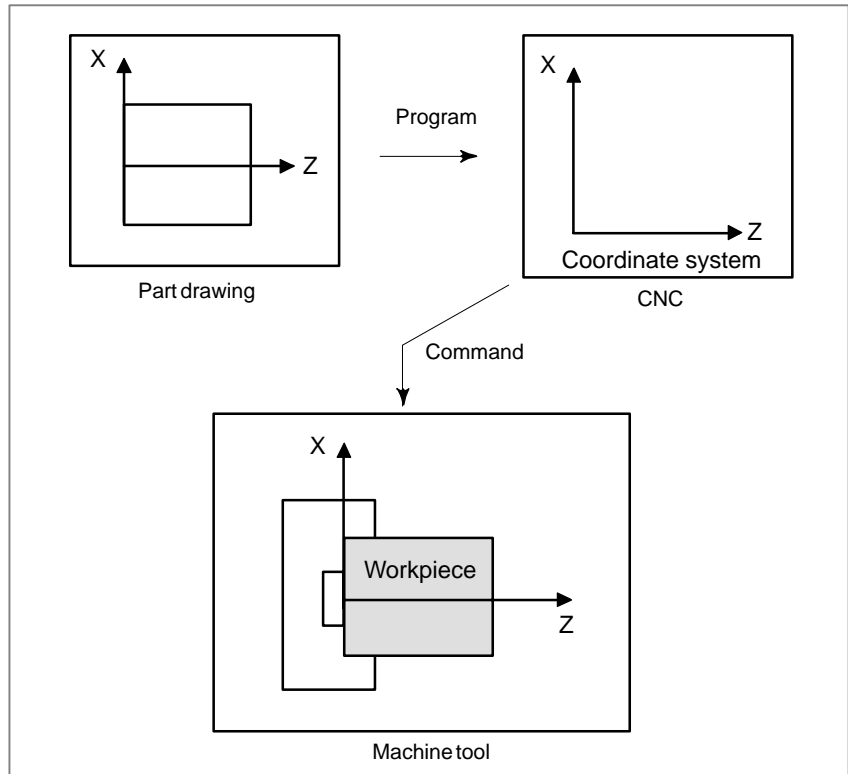

Fig. 1.3.2 (a) Coordinate system

Explanations

- **Coordinate system**

The following two coordinate systems are specified at different locations:
(See II-7)

1. **Coordinate system on part drawing**
The coordinate system is written on the part drawing. As the program data, the coordinate values on this coordinate system are used.
2. **Coordinate system specified by the CNC**
The coordinate system is prepared on the actual machine tool. This can be achieved by programming the distance from the current position of the tool to the zero point of the coordinate system to be set.

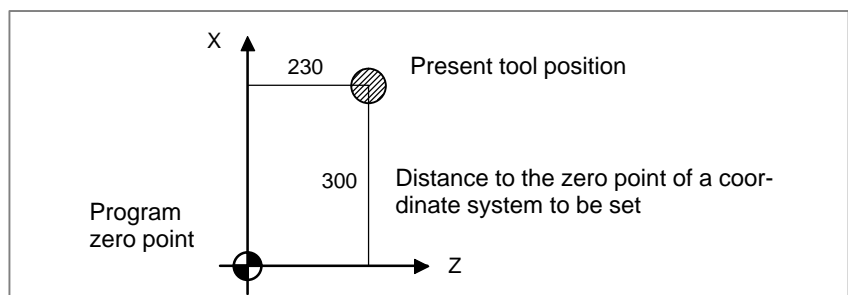

Fig. 1.3.2 (b) Coordinate system specified by the CNC

The tool moves on the coordinate system specified by the CNC in accordance with the command program generated with respect to the coordinate system on the part drawing, and cuts a workpiece into a shape on the drawing.

Therefore, in order to correctly cut the workpiece as specified on the drawing, the two coordinate systems must be set at the same position.

- **Methods of setting the two coordinate systems in the same position**

The following method is usually used to define two coordinate systems at the same location.

1. When coordinate zero point is set at chuck face

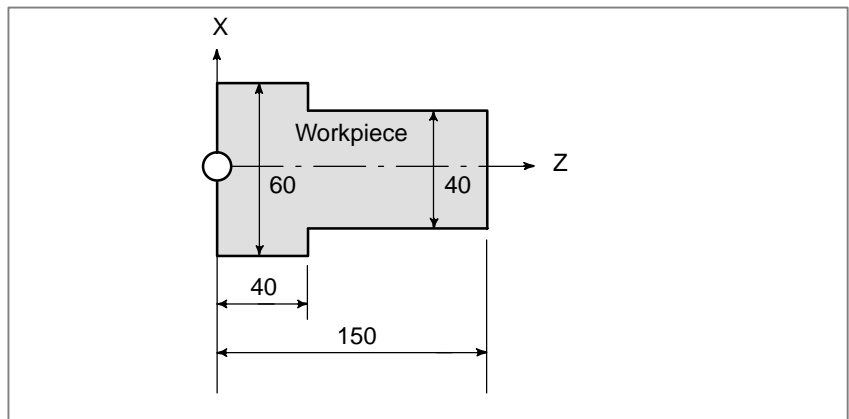

Fig. 1.3.2 (c) Coordinates and dimensions on part drawing

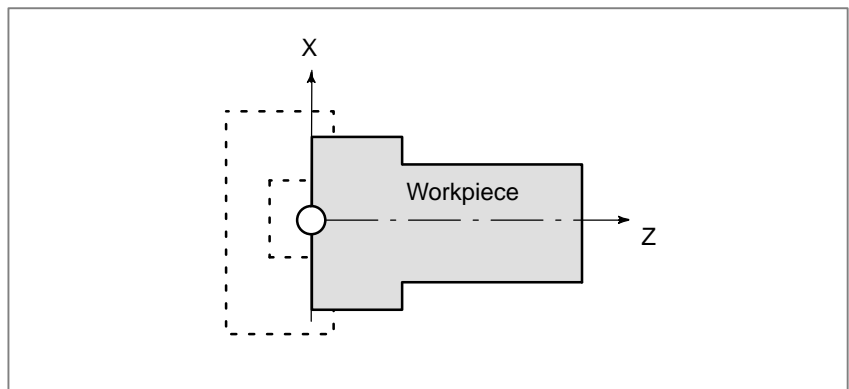

Fig. 1.3.2 (d) Coordinate system on lathe as specified by CNC (made to coincide with the coordinate system on part drawing)

2. When coordinate zero point is set at work end face.

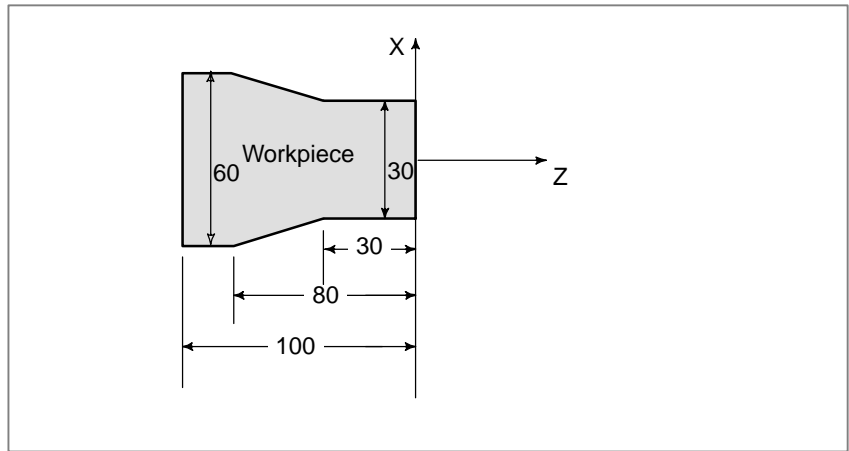

Fig. 1.3.2 (e) Coordinates and dimensions on part drawing

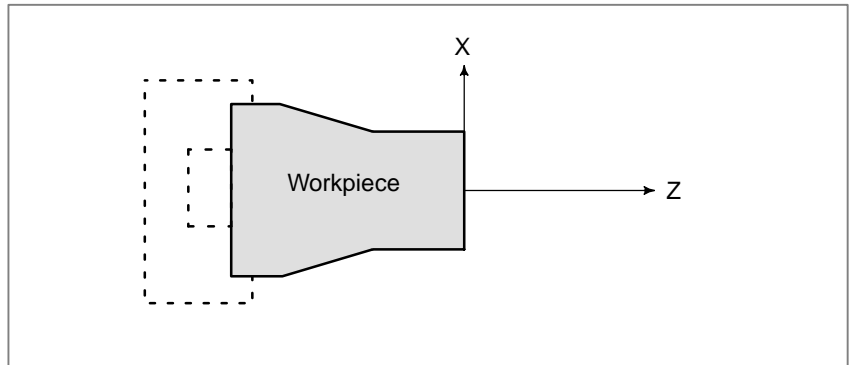

Fig. 1.3.2 (f) Coordinate system on lathe as specified by CNC (made to coincide with the coordinate system on part drawing)

1.3.3 How to Indicate Command Dimensions for Moving the Tool – Absolute, Incremental Commands

Explanations

- **Absolute command**

Methods of command for moving the tool can be indicated by absolute or incremental designation (See II-8.1).

The tool moves to a point at “the distance from zero point of the coordinate system” that is to the position of the coordinate values.

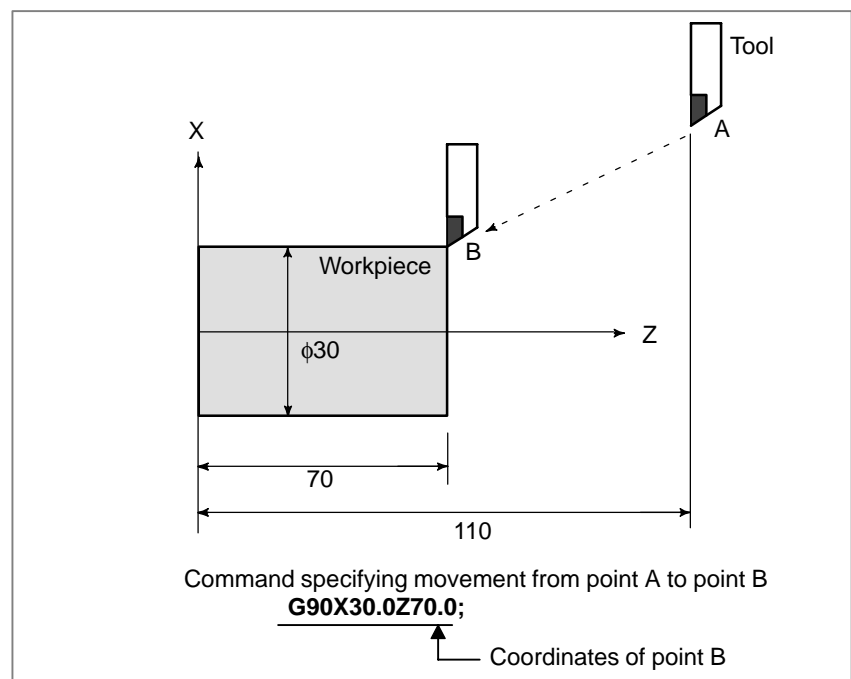

Fig. 1.3.3 (a) Absolute command

● **Incremental command**

Specify the distance from the previous tool position to the next tool position.

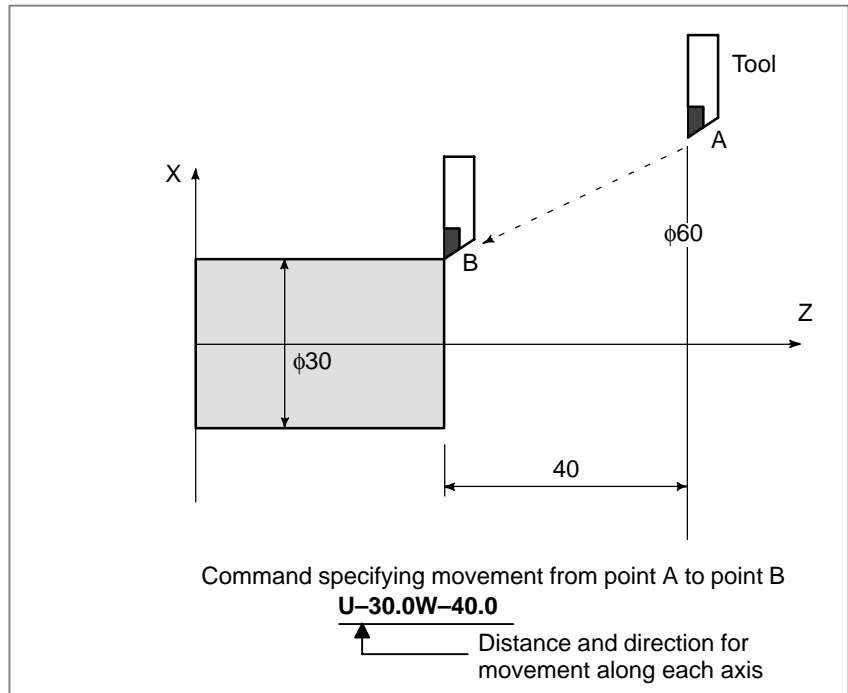

Fig. 1.3.3 (b) Incremental command

● **Diameter programming / radius programming**

Dimensions of the X axis can be set in diameter or in radius. Diameter programming or radius programming is employed independently in each machine.

1. Diameter programming

In diameter programming, specify the diameter value indicated on the drawing as the value of the X axis.

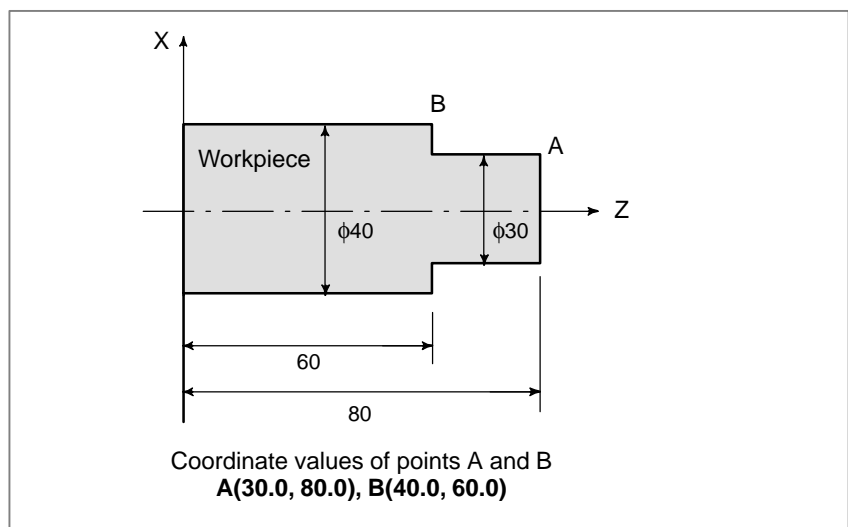

Fig. 1.3.3 (c) Diameter programming

2. Radius programming

In radius programming, specify the distance from the center of the workpiece, i.e. the radius value as the value of the X axis.

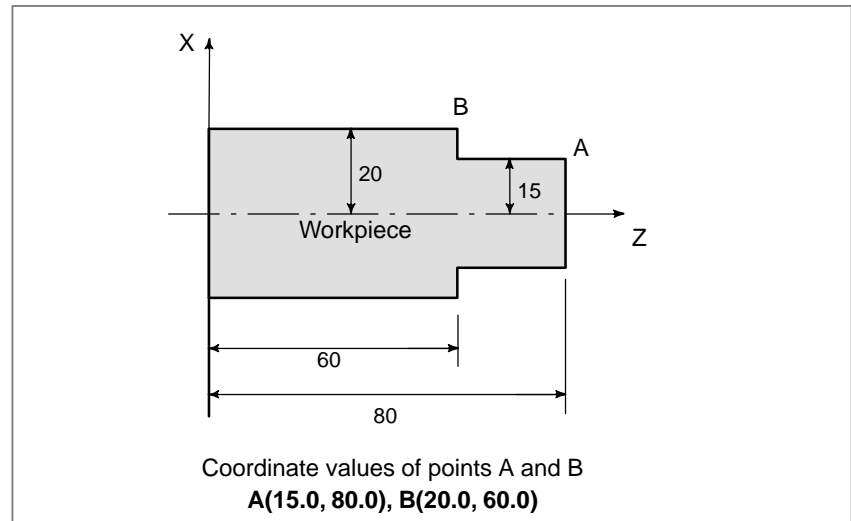

Fig. 1.3.3 (d) Radius programming

1.4 CUTTING SPEED – SPINDLE SPEED FUNCTION

The speed of the tool with respect to the workpiece when the workpiece is cut is called the cutting speed.

As for the CNC, the cutting speed can be specified by the spindle speed in min^{-1} unit.

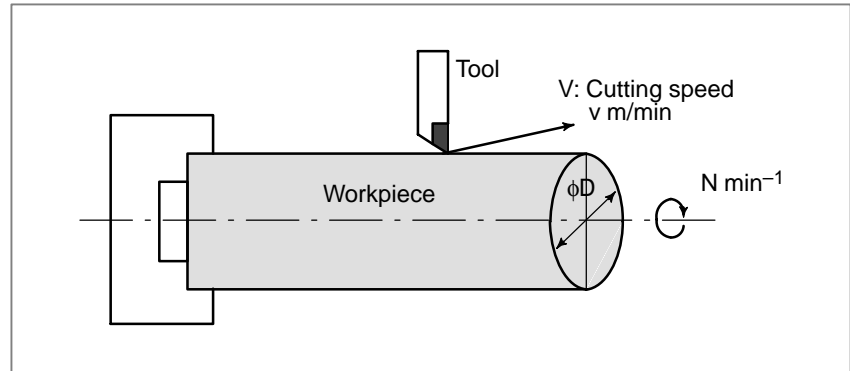

Fig. 1.4 Cutting speed

Examples

<When a workpiece 200 mm in diameter should be machined at a cutting speed of 300 m/min. >

The spindle speed is approximately 478 min^{-1} , which is obtained from $N=1000v/\pi D$. Hence the following command is required:

S478 ;

Commands related to the spindle speed are called the spindle speed function (See II-9).

The cutting speed v (m/min) can also be specified directly by the speed value. Even when the workpiece diameter is changed, the CNC changes the spindle speed so that the cutting speed remains constant.

This function is called the constant surface speed control function (See II-9.3).

1.5 SELECTION OF TOOL USED FOR VARIOUS MACHINING – TOOL FUNCTION

When drilling, tapping, boring, milling or the like, is performed, it is necessary to select a suitable tool. When a number is assigned to each tool and the number is specified in the program, the corresponding tool is selected.

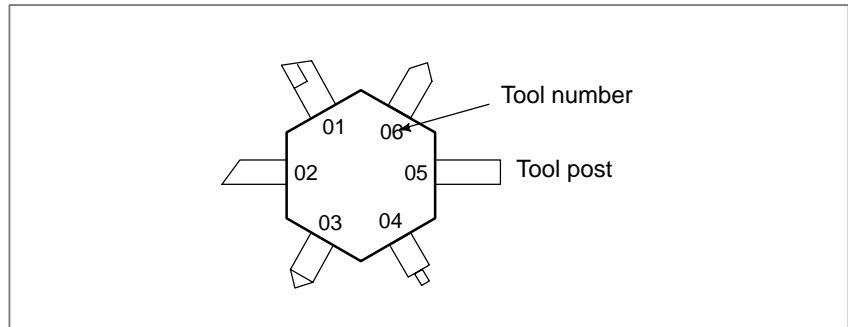

Fig. 1.5 Tool used for various machining

Examples

<When No.01 is assigned to a roughing tool>

When the tool is stored at location 01 of the tool post, the tool can be selected by specifying **T0101**.

This is called the tool function (See II-10).

1.6 COMMAND FOR MACHINE OPERATIONS – MISCELLANEOUS FUNCTION

When machining is actually started, it is necessary to rotate the spindle, and feed coolant. For this purpose, on–off operations of spindle motor and coolant valve should be controlled (See II–11).

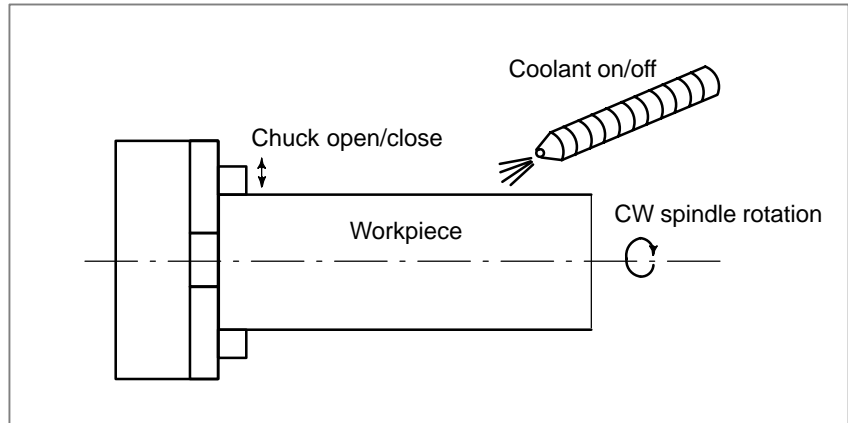

Fig. 1.6 Command for machine operations

The function of specifying the on–off operations of the components of the machine is called the miscellaneous function. In general, the function is specified by an M code.

For example, when M03 is specified, the spindle is rotated clockwise at the specified spindle speed.

1.7 PROGRAM CONFIGURATION

A group of commands given to the CNC for operating the machine is called the program. By specifying the commands, the tool is moved along a straight line or an arc, or the spindle motor is turned on and off. In the program, specify the commands in the sequence of actual tool movements.

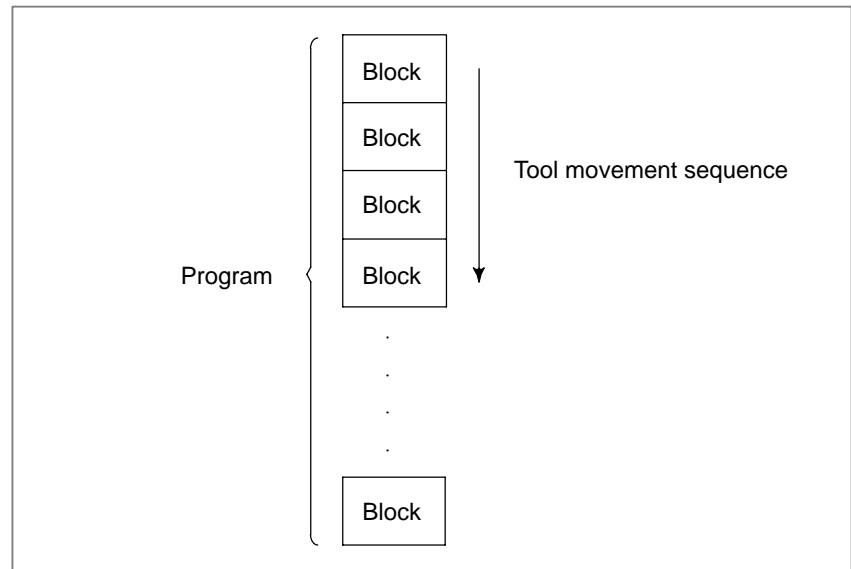

Fig. 1.7 (a) Program configuration

A group of commands at each step of the sequence is called the block. The program consists of a group of blocks for a series of machining. The number for discriminating each block is called the sequence number, and the number for discriminating each program is called the program number (See II-12).

Explanations

The block and the program have the following configurations.

• **Block**

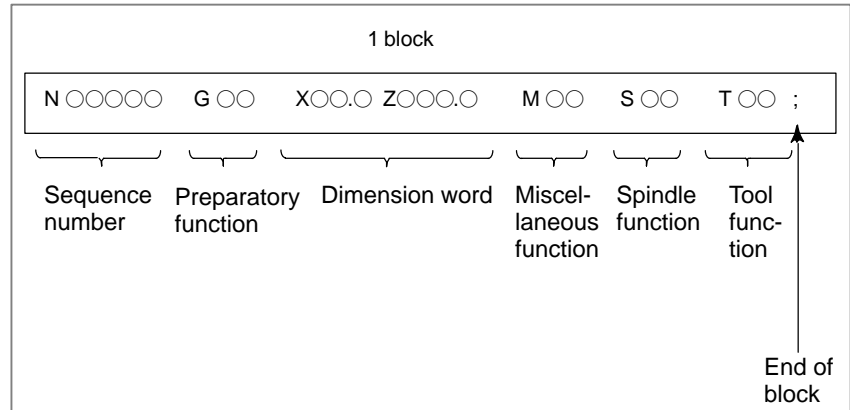

Fig. 1.7 (b) Block configuration

A block begins with a sequence number that identifies that block and ends with an end-of-block code.

This manual indicates the end-of-block code by ; (LF in the ISO code and CR in the EIA code).

The contents of the dimension word depend on the preparatory function. In this manual, the portion of the dimension word may be represent as IP_.

• **Program**

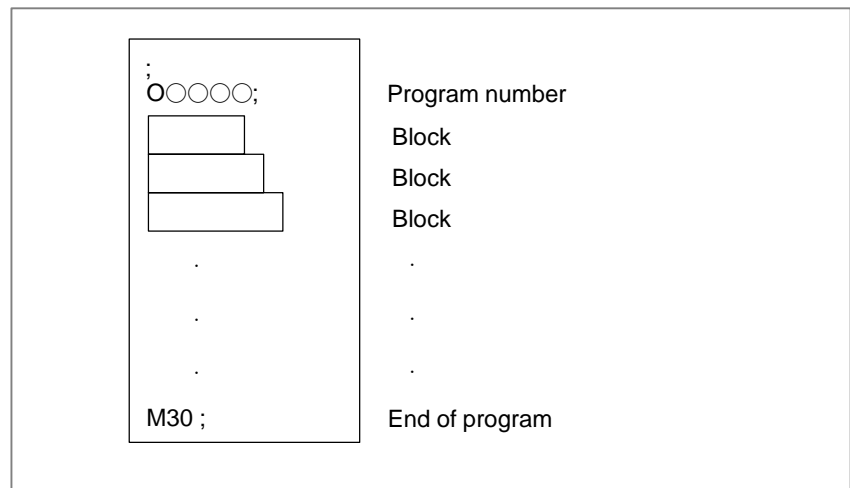
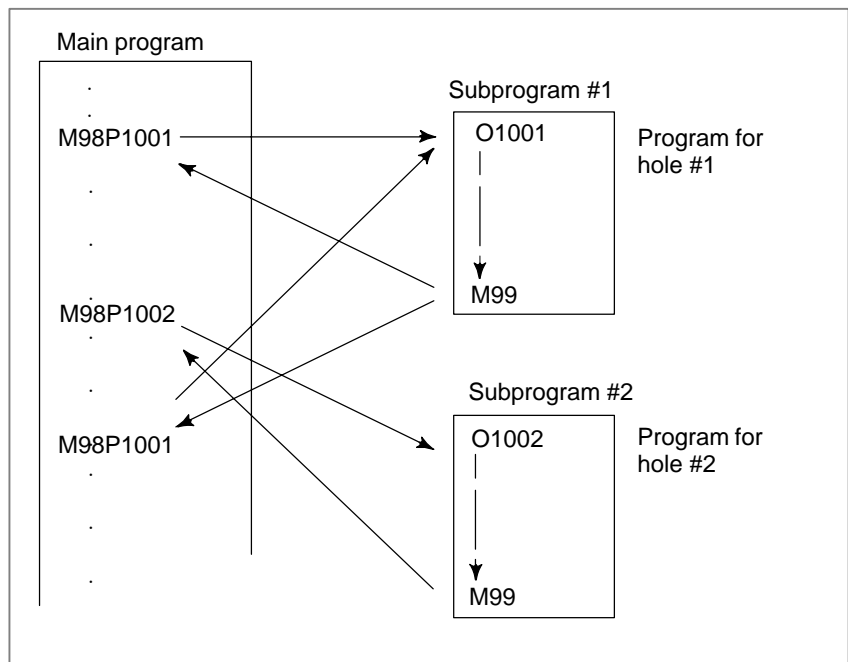

Fig. 1.7 (c) Program configuration

Normally, a program number is specified after the end-of-block (;) code at the beginning of the program, and a program end code (M02 or M30) is specified at the end of the program.

- **Main program and subprogram**

When machining of the same pattern appears at many portions of a program, a program for the pattern is created. This is called the subprogram. On the other hand, the original program is called the main program. When a subprogram execution command appears during execution of the main program, commands of the subprogram are executed. When execution of the subprogram is finished, the sequence returns to the main program.



1.8 TOOL FIGURE AND TOOL MOTION BY PROGRAM

Explanations

- **Machining using the end of cutter – Tool length compensation function (See II-15.1)**

Usually, several tools are used for machining one workpiece. The tools have different tool length. It is very troublesome to change the program in accordance with the tools.

Therefore, the length of each tool used should be measured in advance. By setting the difference between the length of the standard tool and the length of each tool in the CNC (data display and setting : see III-11), machining can be performed without altering the program even when the tool is changed. This function is called tool length compensation.

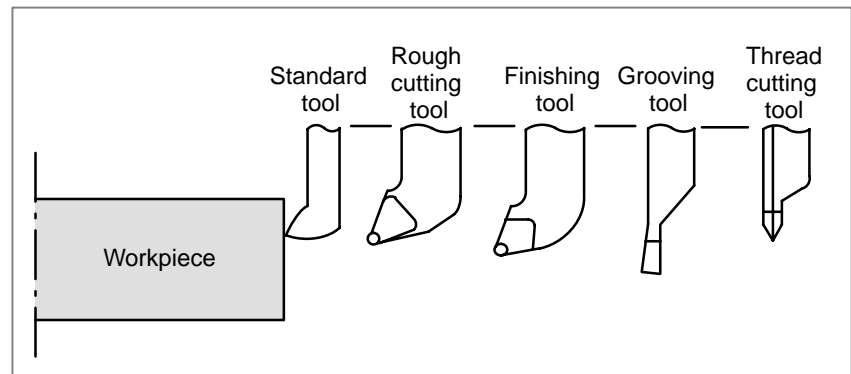
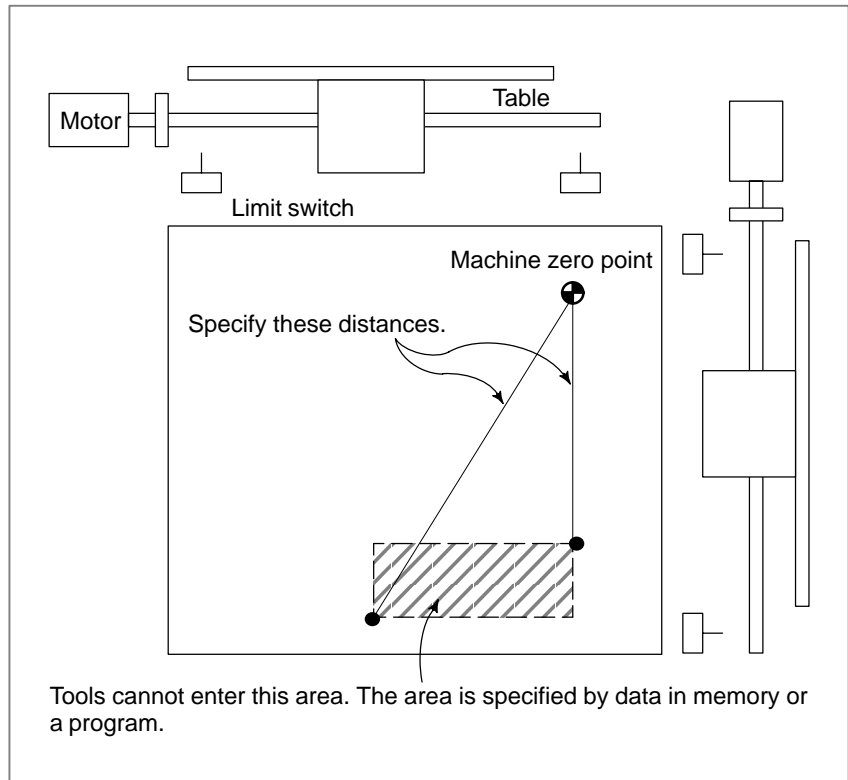

Fig. 1.8 Tool offset

1.9 TOOL MOVEMENT RANGE – STROKE

Limit switches are installed at the ends of each axis on the machine to prevent tools from moving beyond the ends. The range in which tools can move is called the stroke. Besides the stroke limits, data in memory can be used to define an area which tools cannot enter.



Besides strokes defined with limit switches, the operator can define an area which the tool cannot enter using a program or data in memory. This function is called stroke check (See III-6.3).

2 CONTROLLED AXES



2.1 CONTROLLED AXES

Series 16i Series 160i

Item	16i-TB 160i-TB	16i-TB, 160i-TB (two-path control)
Number of basic controlled axes	2 axes	2 axes for each tool post (4 axes in total)
Controlled axis expansion (total)	Max. 8 axes (Included in Cs axis)	Max. 8 axes for each tool post (Included in Cs axis) (Note)
Number of basic simultaneously controlled axes	2 axes	2 axes for each tool post (4 axes in total)
Simultaneously controlled axis expansion (total)	Max. 6 axes	Max. 6 axes for each tool post

The table above lists the number of controlled axes of one-path control and two-CPU two-path control. For the number of controlled axes of one-CPU two-path control and two-CPU three-path control, refer to the specifications.

NOTE

- 1 A two-path control system with the 7.2"/8.4" LCD has up to eight controlled axes.
- 2 The number of simultaneously controllable axes for manual operation (jog feed, incremental feed, or manual handle feed) is 1 or 3 (1 when bit 0 (JAX) of parameter 1002 is set to 0 and 3 when it is set to 1).

Series 18i Series 180i

Item	18i-TB 180i-TB	18i-TB, 180i-TB (two-path control)
Number of basic controlled axes	2 axes	2 axes for each tool post (4 axes in total)
Controlled axis expansion (total)	Max. 6 axes (Included in Cs axis)	Max. 6 axes for each tool post (Included in Cs axis) (Note)
Number of basic simultaneously controlled axes	2 axes	2 axes for each tool post (4 axes in total)
Simultaneously controlled axis expansion (total)	Max. 4 axes	Max. 4 axes for each tool post

The table above lists the number of controlled axes of one-path control and two-CPU two-path control.

For the number of controlled axes of one-CPU two-path control, refer to the specifications.

NOTE

- 1 A two-path control system with the 7.2"/8.4" LCD has up to eight controlled axes.
- 2 The number of simultaneously controllable axes for manual operation (jog feed, incremental feed, or manual handle feed) is 1 or 3 (1 when bit 0 (JAX) of parameter 1002 is set to 0 and 3 when it is set to 1).

2.2 NAMES OF AXES

The names of two basic axes are always X and Z; the names of additional axes can be optionally selected from A, B, C, U, V, W, and Y by using parameter No.1020.

Each axis name is determined according to parameter No. 1020. If the parameter specifies 0 or anything other than the nine letters, the axis name defaults to a number from 1 to 8.

With two-path control, the names of two basic axes for one tool post are always X and Z; the names of additional axes can be optionally selected from A, B, C, U, V, W, and Y by using parameter No. 1020. For one tool post, the same axis name cannot be assigned to multiple axes, but the same axis name can be used with the other tool post.

Limitations

- **Default axis name**

When a default axis name (1 to 8) is used, the system cannot operate in MEM, MDI, or RMT mode.

- **Duplicate axis name**

If the parameter specifies an axis name more than once, only the first axis to be assigned that axis name becomes operable.

NOTE

1 When G code system A is used, the letters U, V, and W cannot be used as an axis name (hence, the maximum of six controlled axes), because these letters are used as incremental commands for X, Y, and Z. To use the letters U, V, and W as axis names, the G code system must be B or C. Likewise, letter H is used as an incremental command for C, thus incremental commands cannot be used if A or B is used as an axis name.

2 With two-path control, when information (such as the current position) about each axis is displayed on the screen, an axis name may be followed by a subscript to indicate a tool post number (e.g., X1 and X2). This is axis name to help the user to easily understand which tool post an axis belongs to. When writing a program, the user must specify X, Y, Z, U, V, W, A, B, and C without attaching a subscript.

3 In G76 (multiple-thread cutting), the A address in a block specifies the tool nose angle instead of a command for axis A.

If C or A is used as an axis name, C or A cannot be used as an angle command for a straight line in chamfering or direct drawing dimension programming. Therefore, C and A should be used according to bit 4 (CCR) of parameter No. 3405.

2.3 INCREMENT SYSTEM

The increment system consists of the least input increment (for input) and least command increment (for output). The least input increment is the least increment for programming the travel distance. The least command increment is the least increment for moving the tool on the machine. Both increments are represented in mm, inches, or degrees.

The increment system is classified into IS-B and IS-C (Tables 2.3 (a) and 2.3 (b)). Select IS-B or IS-C using bit 1 (ISC) of parameter 1004. When the IS-C increment system is selected, it is applied to all axes and the 1/10 increment system option is required. The setting of parameter ISC (No. 1004#4) is valid for all axes. When IS-C is selected, for example, the setting units for all axes are IS-C.

Table 2.3 (a) Increment system IS-B

		Least input increment	Least command increment
Metric system machine	mm input	0.001 mm (Diameter)	0.0005 mm
		0.001 mm (Radius)	0.001 mm
		0.001 deg	0.001 deg
	inch input	0.0001 inch (Diameter)	0.0005 inch
		0.0001 inch (Radius)	0.001 inch
		0.001 deg	0.001 deg
Inch machine system	mm input	0.001 mm (Diameter)	0.00005 mm
		0.001 mm (Radius)	0.0001 mm
		0.001 deg	0.001 deg
	inch input	0.0001 inch (Diameter)	0.00005 inch
		0.0001 inch (Radius)	0.0001 inch
		0.001 deg	0.001 deg

Table 2.3 (b) Increment system IS-C

		Least input increment	Least command increment
Metric system machine	mm input	0.0001 mm (Diameter)	0.00005 mm
		0.0001 mm (Radius)	0.0001 mm
		0.0001 deg	0.0001 deg
	inch input	0.00001 inch (Diameter)	0.00005 inch
		0.00001 inch (Radius)	0.0001 inch
		0.0001 deg	0.0001 deg
Inch machine system	mm input	0.0001 mm (Diameter)	0.000005 mm
		0.0001 mm (Radius)	0.00001 mm
		0.0001 deg	0.0001 deg
	inch input	0.00001 inch (Diameter)	0.000005 inch
		0.00001 inch (Radius)	0.00001 inch
		0.0001 deg	0.0001 deg

2.4 MAXIMUM STROKES

The maximum stroke controlled by this CNC is shown in the table below:
 Maximum stroke = Least command increment × 99999999.

Table 2.4 Maximum strokes

Increment system		Maximum strokes
IS-B	Metric machine system	± 99999.999 mm ± 99999.999 deg
	Inch machine system	± 9999.9999 inch ± 99999.999 deg
IS-C	Metric machine system	± 9999.9999 mm ± 9999.9999 deg
	Inch machine system	± 999.99999 inch ± 9999.9999 deg

NOTE

- 1 The unit in the table 2.4 is a diameter value with diameter programming and a radius value in radius programming.
- 2 A command exceeding the maximum stroke cannot be specified.
- 3 The actual stroke depends on the machine tool.

3

PREPARATORY FUNCTION (G FUNCTION)

A number following address G determines the meaning of the command for the concerned block.

G codes are divided into the following two types.

Type	Meaning
One-shot G code	The G code is effective only in the block in which it is specified
Modal G code	The G code is effective until another G code of the same group is specified.

(Example)

G01 and G00 are modal G codes.

```

G01X_;
  Z_;
  X_;
G00Z_;
  } G01 is effective in this range

```

There are three G code systems : A,B, and C (Table 3). Select a G code system using bits 6 (GSB) and 7 (GSC) of parameter 3401. To use G code system B or C, the corresponding option is needed. Generally, this manual describes the use of G code system A, except when the described item can use only G code system B or C. In such cases, the use of G code system B or C is described.

Explanations

1. If the CNC enters the clear state (see bit 6 (CLR) of parameter 3402) when the power is turned on or the CNC is reset, the modal G codes change as follows.
 - (1) G codes marked with  in Table 3 are enabled.
 - (2) When the system is cleared due to power-on or reset, whichever specified, either G20 or G21, remains effective.
 - (3) Bit 7 of parameter No. 3402 can be used to specify whether G22 or G23 is selected upon power-on. Resetting the CNC to the clear state does not affect the selection of G22 or G23.
 - (4) Setting bit 0 (G01) of parameter 3402 determines which code, either G00 or G01, is effective.
 - (5) When G code system B or C is used, setting bit 3 (G91) of parameter 3402 determines which code, either G90 or G91, is effective.
2. G codes of group 00 except G10 and G11 are single-shot G codes.
3. P/S alarm (No.010) is displayed when a G code not listed in the G code list is specified or a G code without a corresponding option is specified.
4. G codes of different groups can be specified in the same block. If G codes of the same group are specified in the same block, the G code specified last is valid.
5. If a G code of group 01 is specified in a canned cycle, the canned cycle is canceled in the same way as when a G80 command is specified. G codes of group 01 are not affected by G codes for specifying a canned cycle.
6. When G code system A is used, absolute or incremental programming is specified not by a G code (G90/G91) but by an address word (X/U, Z/W, C/H, Y/V). When G code system A is used for a drilling cycle, only the initial level is provided at the return point.
7. G codes are displayed for each group number.

Table 3 G code list for T series (1/3)

G code			Group	Function	
A	B	C			
↙ G00	↙ G00	↙ G00	01	Positioning (Rapid traverse)	
G01	G01	G01		Linear interpolation (Cutting feed)	
G02	G02	G02		Circular interpolation CW or helical interpolation CW	
G03	G03	G03		Circular interpolation CCW or helical interpolation CCW	
G04	G04	G04	00	Dwell	
G05	G05	G05		High-speed cycle cutting	
G07	G07	G07		Hypothetical axis interpolation	
G07.1 (G107)	G07.1 (G107)	G07.1 (G107)		Cylindrical interpolation	
G08	G08	G08		Look-ahead control	
G10	G10	G10		Programmable data input	
G10.6	G10.6	G10.6		Tool retract and return	
G11	G11	G11		Programmable data input mode cancel	
G12.1 (G112)	G12.1 (G112)	G12.1 (G112)		21	Polar coordinate interpolation mode
↙ G13.1 (G113)	↙ G13.1 (G113)	↙ G13.1 (G113)			Polar coordinate interpolation cancel mode
G17	G17	G17	16	XpYp plane selection	
↙ G18	↙ G18	↙ G18		ZpXp plane selection	
G19	G19	G19		YpZp plane selection	
G20	G20	G70	06	Input in inch	
G21	G21	G71		Input in mm	
↙ G22	↙ G22	↙ G22	09	Stored stroke check function on	
G23	G23	G23		Stored stroke check function off	
↙ G25	↙ G25	↙ G25	08	Spindle speed fluctuation detection off	
G26	G26	G26		Spindle speed fluctuation detection on	
G27	G27	G27	00	Reference position return check	
G28	G28	G28		Return to reference position	
G30	G30	G30		2nd, 3rd and 4th reference position return	
G30.1	G30.1	G30.1		Floating reference point return	
G31	G31	G31		Skip function	
G32	G33	G33	01	Thread cutting	
G34	G34	G34		Variable-lead thread cutting	
G35	G35	G35		Circular threading CW	
G36	G36	G36		Circular threading CCW (When the bit 3 (G36) of parameter No. 3405 is set to 1)	

Table 3 G code list for T series (2/3)

G code			Group	Function
A	B	C		
G36	G36	G36	00	Automatic tool compensation X (When the bit 3 (G36) of parameter No. 3405 is set to 0)
G37	G37	G37		Automatic tool compensation Z
G37.1	G37.1	G37.1		Automatic tool compensation X
G37.2	G37.2	G37.2		Automatic tool compensation Z
G39	G39	G39		Corner circular interpolation
G40	G40	G40	07	Tool nose radius compensation cancel
G41	G41	G41		Tool nose radius compensation left
G42	G42	G42		Tool nose radius compensation right
G50	G92	G92	00	Coordinate system setting or max. spindle speed setting
G50.3	G92.1	G92.1		Workpiece coordinate system preset
G50.2 (G250)	G50.2 (G250)	G50.2 (G250)	20	Polygonal turning cancel
G51.2 (G251)	G51.2 (G251)	G51.2 (G251)		Polygonal turning
G52	G52	G52	00	Local coordinate system setting
G53	G53	G53		Machine coordinate system setting
G54	G54	G54	14	Workpiece coordinate system 1 selection
G55	G55	G55		Workpiece coordinate system 2 selection
G56	G56	G56		Workpiece coordinate system 3 selection
G57	G57	G57		Workpiece coordinate system 4 selection
G58	G58	G58		Workpiece coordinate system 5 selection
G59	G59	G59		Workpiece coordinate system 6 selection
G60	G60	G60	00	Single direction positioning
G65	G65	G65		Macro calling
G66	G66	G66	12	Macro modal call
G67	G67	G67		Macro modal call cancel
G68	G68	G68	04	Mirror image for double turrets ON or balance cut mode
G68.1	G68.1	G68.1	17	Coordinate system rotation start or three-dimensional coordinate system conversion mode on
G69	G69	G69	04	Mirror image for double turrets OFF or balance cut mode cancel
G69.1	G69.1	G69.1	17	Coordinate system rotation cancel or three-dimensional coordinate system conversion mode off

Table 3 G code list for T series (3/3)

G code			Group	Function
A	B	C		
G70	G70	G72	00	Finishing cycle
G71	G71	G73		Stock removal in turning
G72	G72	G74		Stock removal in facing
G73	G73	G75		Pattern repeating
G74	G74	G76		End face peck drilling
G75	G75	G77		Outer diameter/internal diameter drilling
G76	G76	G78		Multiple threading cycle
G71	G71	G72	01	Traverse grinding cycle (for grinding machine)
G72	G72	G73		Traverse direct constant-dimension grinding cycle (for grinding machine)
G73	G73	G74		Oscillation grinding cycle (for grinding machine)
G74	G74	G75		Oscillation direct constant-dimension grinding cycle (for grinding machine)
G80	G80	G80	10	Canned cycle for drilling cancel
G83	G83	G83		Cycle for face drilling
G84	G84	G84		Cycle for face tapping
G86	G86	G86		Cycle for face boring
G87	G87	G87		Cycle for side drilling
G88	G88	G88		Cycle for side tapping
G89	G89	G89		Cycle for side boring
G90	G77	G20	01	Outer diameter/internal diameter cutting cycle
G92	G78	G21		Thread cutting cycle
G94	G79	G24		Endface turning cycle
G96	G96	G96	02	Constant surface speed control
G97	G97	G97		Constant surface speed control cancel
G98	G94	G94	05	Per minute feed
G99	G95	G95		Per rotation feed
-	G90	G90	03	Absolute programming
-	G91	G91		Incremental programming
-	G98	G98	11	Return to initial level (See Explanation 6.)
-	G99	G99		Return to R point level (See Explanation 6.)
G100	G100	G100	00	B axis control-Program registration completion
G101	G101	G101		B axis control-First program registration start
G102	G102	G102		B axis control-Second program registration start
G103	G103	G103		B axis control-Third program registration start
G110	G110	G110		B axis control-One motion operation programming

4 INTERPOLATION FUNCTIONS



4.1 POSITIONING (G00)

The G00 command moves a tool to the position in the workpiece system specified with an absolute or an incremental command at a rapid traverse rate.

In the absolute command, coordinate value of the end point is programmed.

In the incremental command the distance the tool moves is programmed.

Format

G00IP_;

IP_: For an absolute command, the coordinates of an end position, and for an incremental command, the distance the tool moves.

Explanations

Either of the following tool paths can be selected according to bit 1 (LRP) of parameter No. 1401.

- **Nonlinear interpolation positioning**

The tool is positioned with the rapid traverse rate for each axis separately. The tool path is normally straight.

- **Linear interpolation positioning**

The tool path is the same as in linear interpolation (G01). The tool is positioned within the shortest possible time at a speed that is not more than the rapid traverse rate for each axis.

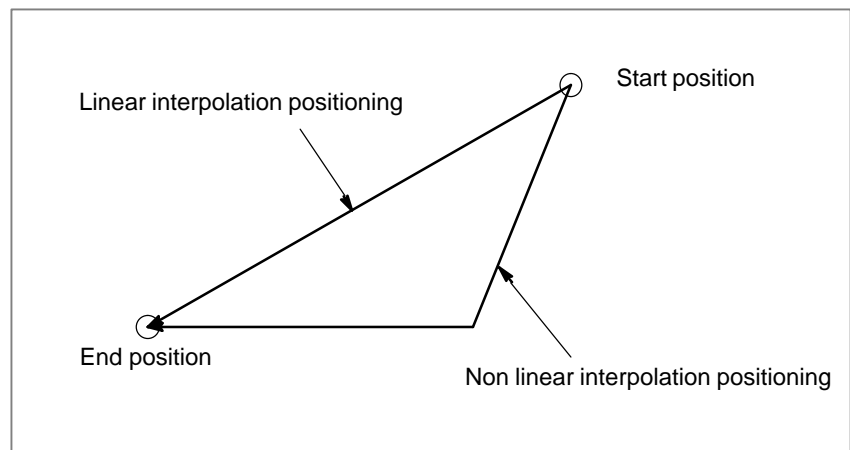

The rapid traverse rate in the G00 command is set to the parameter No. 1420 for each axis independently by the machine tool builder. In the positioning mode actuated by G00, the tool is accelerated to a predetermined speed at the start of a block and is decelerated at the end of a block. Execution proceeds to the next block after confirming the in-position.

“In-position” means that the feed motor is within the specified range.

This range is determined by the machine tool builder by setting to parameter No. 1826.

Examples

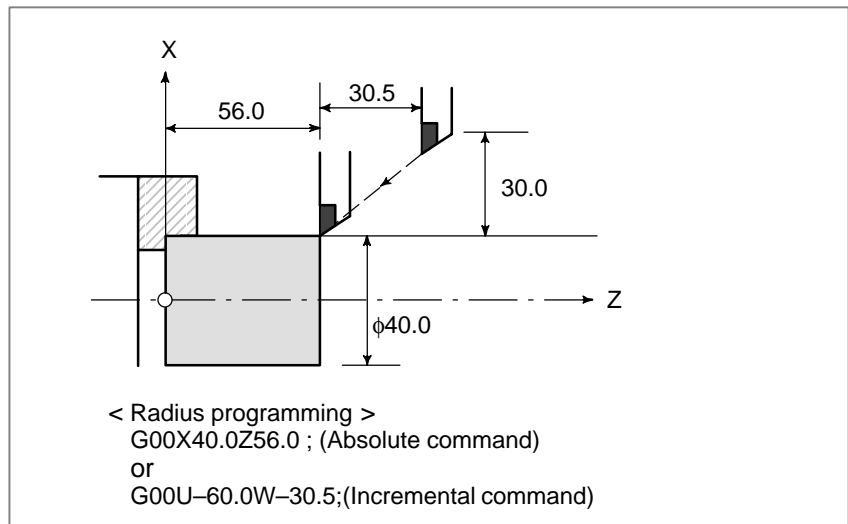

Restrictions

The rapid traverse rate cannot be specified in the address F. Even if linear interpolation positioning is specified, nonlinear interpolation positioning is used in the following cases. Therefore, be careful to ensure that the tool does not foul the workpiece.

- G28 specifying positioning between the reference and intermediate positions.
- G53

4.2 Single Direction Positioning (G60)

General

For accurate positioning without play of the machine (backlash), final positioning from one direction is available.

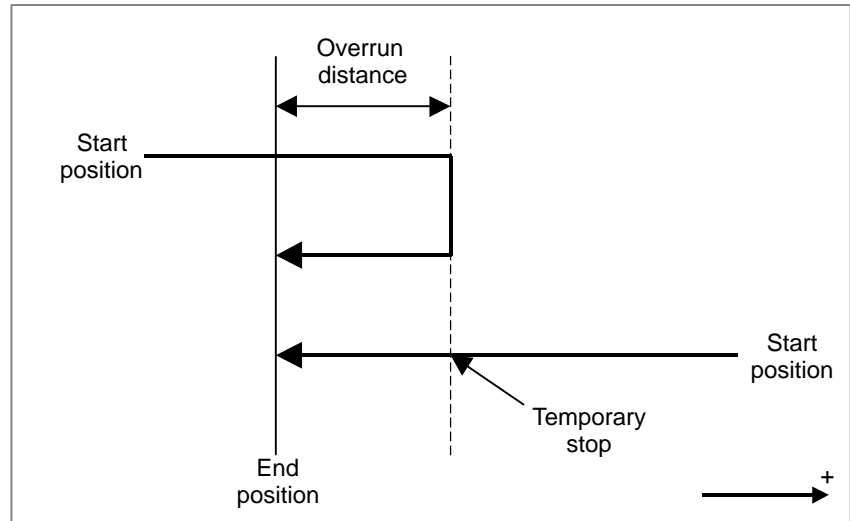

Fig. 4.2 (a) When the positioning direction is minus

Format

G60IP_;

IP_: For an absolute command, the coordinates of an end position, and for an incremental command, the distance the tool moves.

Explanations

An overrun and a positioning direction are set by the parameter (No.5440). Even when a commanded positioning direction coincides with that set by the parameter, the tool stops once before the end point. G60, which is an one-shot G code, can be used as a modal G code in group 01 by setting 1 to the parameter (No. 5431 bit 0 MDL). This setting can eliminate specifying a G60 command for every block. Other specifications are the same as those for an one-shot G60 command. When an one-shot G code is specified in the single direction positioning mode, the one-shot G command is effective like G codes in group 01.

(example)		When one-shot G60 command are used		When modal G60 command is used	
:		:		:	
G90 ;		G90 G60 ;	S.D.P. mode start	G90 G60 ;	S.D.P. mode start
G60 X0 Z0 ;	} Single direction positioning	X0 Z0 ;	Single direction positioning	X0 Z0 ;	Single direction positioning
G60 X100 ;		X100 ;		X100 ;	
G60 Z100 ;		Z100 ;		Z100 ;	
G04 X10 ;		G04 X10 ;		G04 X10 ;	
G00 X0 Z0 ;		G00 X0 Z0 ;	S.D.P. mode cancel	G00 X0 Z0 ;	S.D.P. mode cancel
:		:		:	

Summary of motion

- **When the non-linear positioning is used (parameter No.1401#1 LRP=0)**

The axes are positioned independently from start point by single direction positioning as follows.

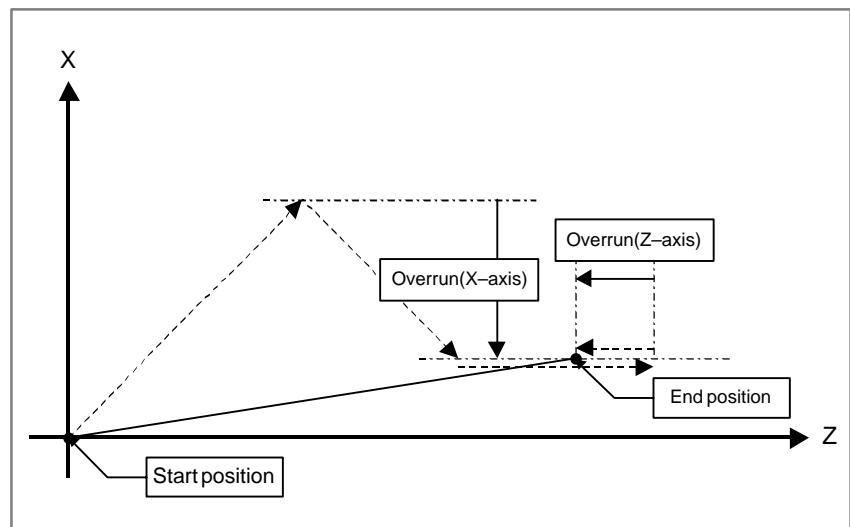

- **When the linear positioning is used (parameter No.1401#1 LRP=1)**

The axes are positioned linear from start position to temporary stop position or overrun position, and are positioned independently from temporary stop position or overrun position to end position.

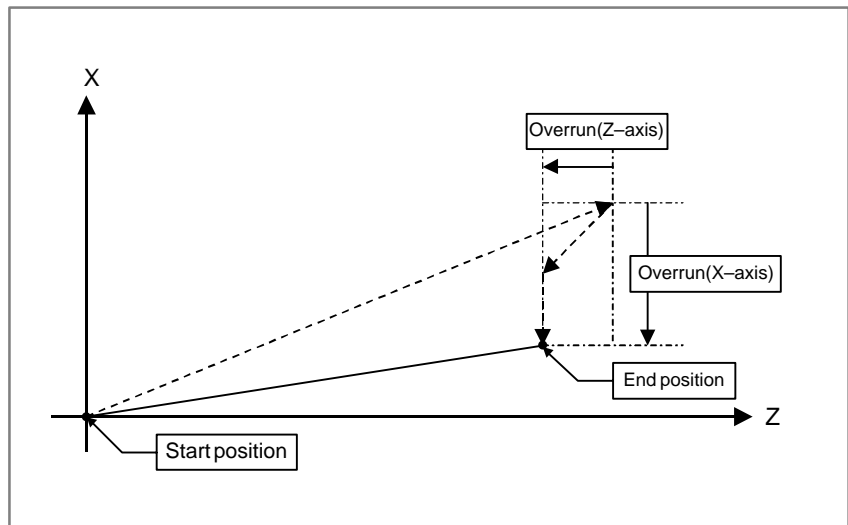
**NOTE**

- 1 Single direction positioning is not performed in an axis for which an overrun has not been set by the parameter (No.5440).
- 2 When the move distance 0 is commanded, the single direction positioning is not performed.
- 3 The mirror image does not influence direction set by the parameter.
The direction does not change during mirror image.
- 4 The G-code for single direction positioning is always G60, if G-code system is A or B or C in all case.
- 5 The single direction positioning can not be commanded during the cylindrical interpolation mode (G07.1).
- 6 The single direction positioning can not be commanded during the polar coordinate interpolation mode (G12.1).
- 7 The single direction positioning can not be commanded during the multiple repetitive cycle (G70-G76).
- 8 The single direction positioning can not be commanded during the canned grinding cycle (G71-G74).
- 9 No single direction positioning is effected in the drilling or patting axis, during canned cycle for drilling (G83-G89) and the rigid tapping (G84, G88). But the single direction positioning is effected in the drilling or patting axis.
- 10 The single direction positioning can not be commanded during the canned cycle (G90, G92, G94).
- 11 During the single direction positioning mode (G60), the following G-code can not be commanded.
G07.1, G12.1, G70-G76, G90-G94.

- **Notice in case of using with the angular axis control.**

In the angular axis control, the distance traveled along the perpendicular axis (X) is corrected by the inclination of the angular axis (Y), and is determined by the following formula.

$$X_a = - Y_p \times \tan\theta$$

The direction of "Xa" is determined by the inclination angle (θ) and the direction of the motion command to the angular axis (Y). In case the value of $\tan\theta$ is plus, the motion command of the angular axis (Y) and the corrected command of the perpendicular (X) is opposite direction. For example, if the inclination angle is 30 degree and the motion command is plus to the angular axis (Y), the corrected command to the perpendicular axis (X) is minus.

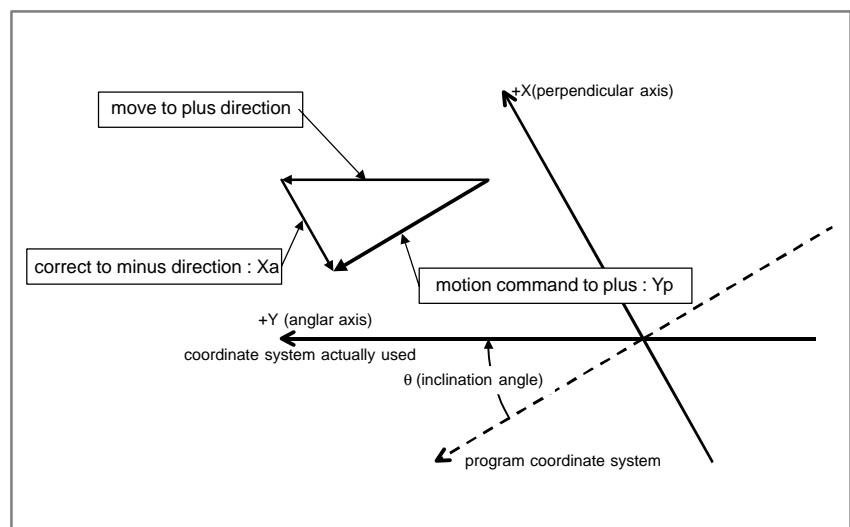

Therefore positioning direction may be disagree with the actual correct direction and the positioning direction of the parameter No.5440 in the perpendicular axis (X) in the single direction positioning with angular axis control.

For avoiding this disagreement, please set the parameter as follows.

- In case the tan value of the inclination angle is plus. (parameter No.8201=1° to 89° or 181° to 269°)

Please set the opposite direction between the angular axis (Y) and the perpendicular axis (X) into the direction of the single direction positioning. If the positioning direction of the perpendicular axis (X) is minus, and the positioning direction of the angular axis (Y) is plus, the motion of the each axes is as follows.

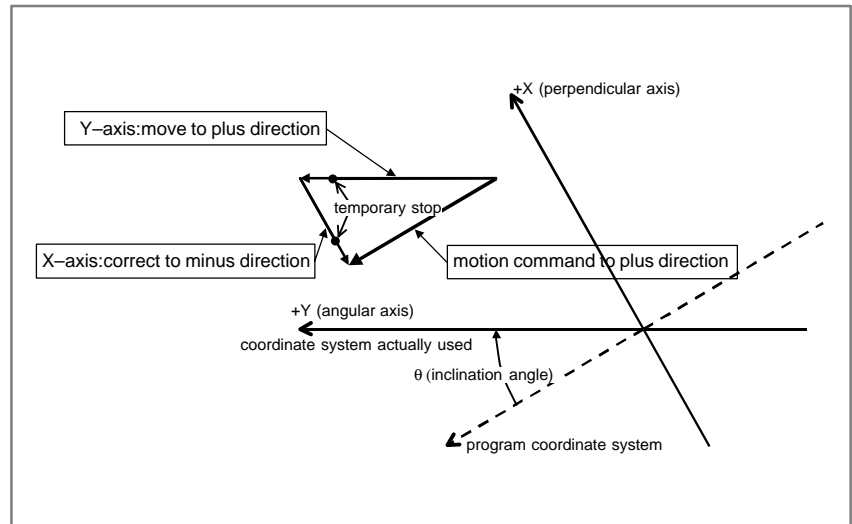

Motion command to plus direction

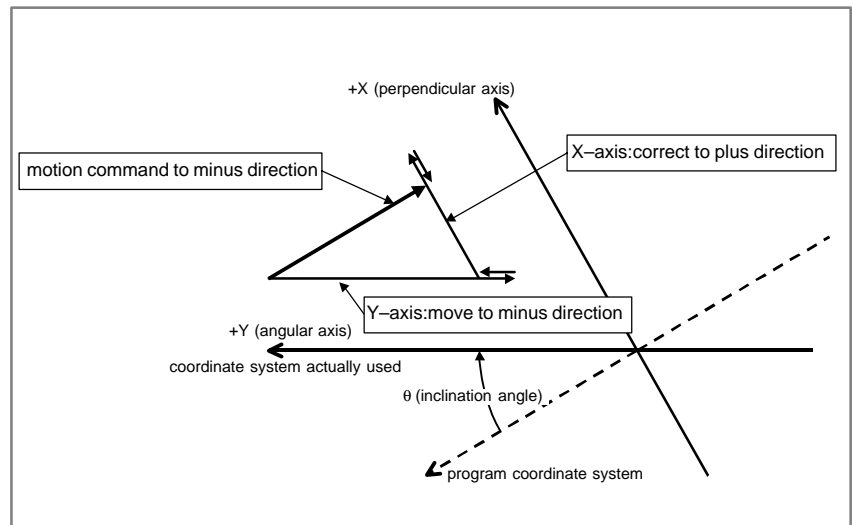

Motion command to minus direction

- In case the tan value of the inclination angle is minus. (parameter No.8201=91° to 179° or 271° to 359°

Please set the same direction between the angular axis (Y) and the perpendicular axis (X) into the direction of the single direction positioning. If the positioning direction of the perpendicular axis (X) is plus, and the positioning direction of the angular axis (Y) is plus, the motion of the each axes is as follows.

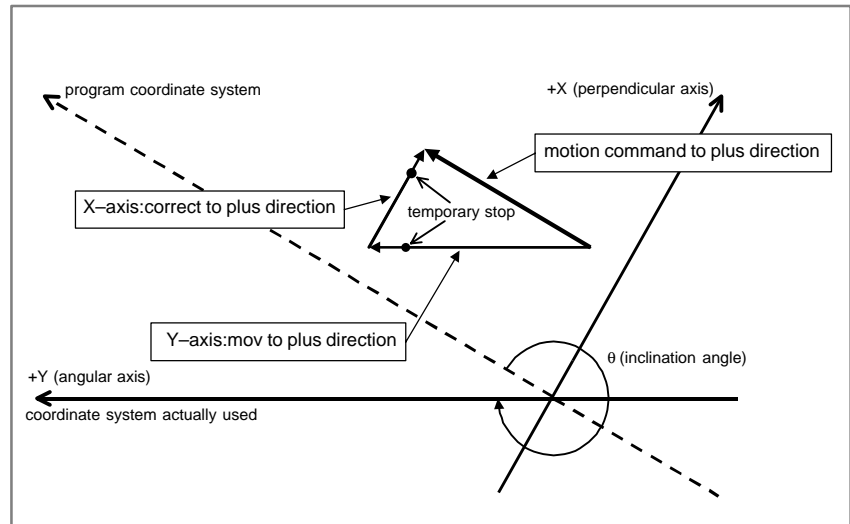

Motion command to plus direction

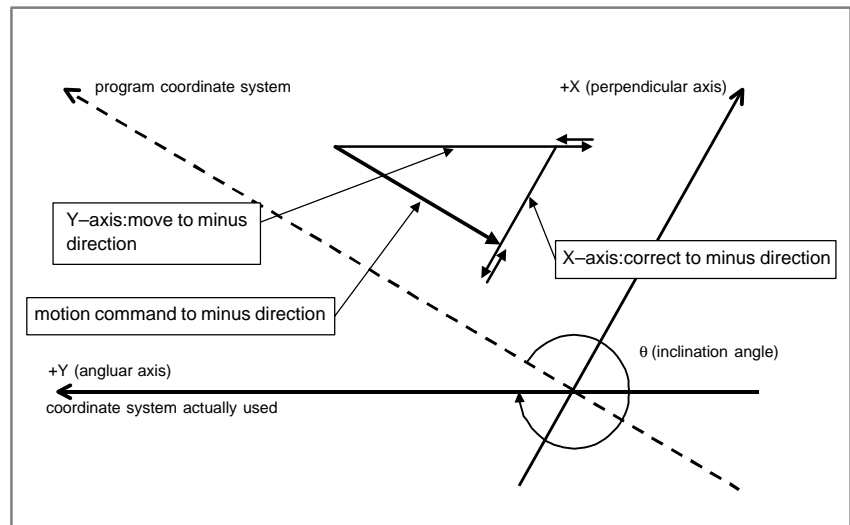

Motion command to minus direction

4.3 LINEAR INTERPOLATION (G01)

Tools can move along a line.

Format

G01 IP_F_;

IP_: For an absolute command, the coordinates of an end point, and for an incremental command, the distance the tool moves.

F_: Speed of tool feed (Feedrate)

Explanations

A tools move along a line to the specified position at the feedrate specified in F.

The feedrate specified in F is effective until a new value is specified. It need not be specified for each block.

The feedrate commanded by the F code is measured along the tool path. If the F code is not commanded, the feedrate is regarded as zero.

For feed-per-minute mode under 2-axis simultaneous control, the feedrate for a movement along each axis as follows :

G01 $\alpha\beta$ Ff ;

Feed rate of α axis direction : $F_{\alpha} = \frac{\alpha}{L} \times f$

Feed rate of β axis direction : $F_{\beta} = \frac{\beta}{L} \times f$

$$L = \sqrt{\alpha^2 + \beta^2}$$

Examples

- Linear interpolation

< Diameter programming >

G01X40.0Z20.1F20 ; (Absolute command)

or

G01U20.0W-25.9F20 ; (Incremental command)

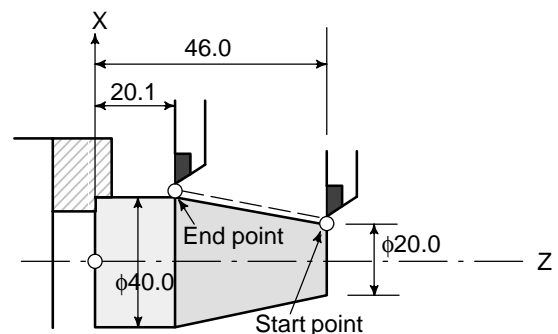

4.4 CIRCULAR INTERPOLATION (G02, G03)

The command below will move a tool along a circular arc.

Format

Arc in the XpYp plane	
$G17 \left\{ \begin{array}{l} G02 \\ G03 \end{array} \right\}$	$Xp_Yp_ \left\{ \begin{array}{l} I_J_ \\ R_ \end{array} \right\} F_$
Arc in the ZpXp plane	
$G18 \left\{ \begin{array}{l} G02 \\ G03 \end{array} \right\}$	$Xp_Zp_ \left\{ \begin{array}{l} I_K_ \\ R_ \end{array} \right\} F_$
Arc in the YpZp plane	
$G19 \left\{ \begin{array}{l} G02 \\ G03 \end{array} \right\}$	$Yp_Zp_ \left\{ \begin{array}{l} J_K_ \\ R_ \end{array} \right\} F_$

Table 4.4 Description of the Command Format

Command	Description
G17	Specification of arc on XpYp plane
G18	Specification of arc on ZpXp plane
G19	Specification of arc on YpZp plane
G02	Circular Interpolation Clockwise direction (CW)
G03	Circular Interpolation Counterclockwise direction (CCW)
Xp_	Command values of X axis or its parallel axis (set by parameter No. 1022)
Yp_	Command values of Y axis or its parallel axis (set by parameter No. 1022)
Zp_	Command values of Z axis or its parallel axis (set by parameter No. 1022)
I_	Xp axis distance from the start point to the center of an arc with sign, radius value
J_	Yp axis distance from the start point to the center of an arc with sign, radius value
k_	Zp axis distance from the start point to the center of an arc with sign, radius value
R_	Arc radius with no sign (always with radius value)
F_	Feedrate along the arc

NOTE

The U-, V-, and W-axes (parallel with the basic axis) can be used with G-codes B and C.

Explanations

• **Direction of the circular interpolation**

“Clockwise” (G02) and “counterclockwise” (G03) on the X_pY_p plane (Z_pX_p plane or Y_pZ_p plane) are defined when the X_pY_p plane is viewed in the positive-to-negative direction of the Z_p axis (Y_p axis or X_p axis, respectively) in the Cartesian coordinate system. See the figure below.

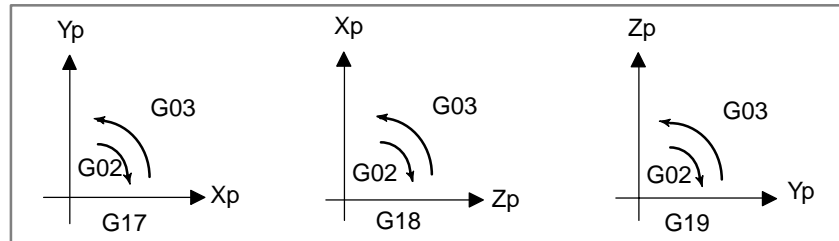

• **Distance moved on an arc**

The end point of an arc is specified by address X_p , Y_p or Z_p , and is expressed as an absolute or incremental value according to G90 or G91. For the incremental value, the distance of the end point which is viewed from the start point of the arc is specified.

• **Distance from the start point to the center of arc**

The arc center is specified by addresses I, J, and K for the X_p , Y_p , and Z_p axes, respectively. The numerical value following I, J, or K, however, is a vector component in which the arc center is seen from the start point, and is always specified as an incremental value irrespective of G90 and G91, as shown below.

I, J, and K must be signed according to the direction.

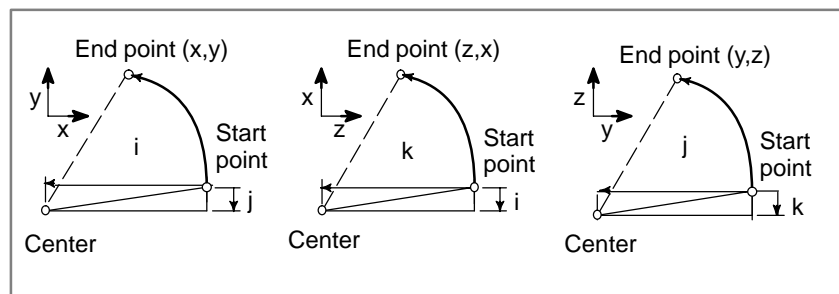

I0, J0, and K0 can be omitted.

If the difference between the radius at the start point and that at the end point exceeds the value in a parameter (No. 3410), an P/S alarm (No. 020) occurs.

• **Full-circle programming**

When X_p , Y_p , and Z_p are omitted (the end point is the same as the start point) and the center is specified with I, J, and K, a 360° arc (circle) is specified.

● **Arc radius**

The distance between an arc and the center of a circle that contains the arc can be specified using the radius, R, of the circle instead of I, J, and K. In this case, one arc is less than 180°, and the other is more than 180° are considered. An arc with a sector angle of 180° or wider cannot be specified. If Xp, Yp, and Zp are all omitted, if the end point is located at the same position as the start point and when R is used, an arc of 0° is programmed

G02R ; (The cutter does not move.)

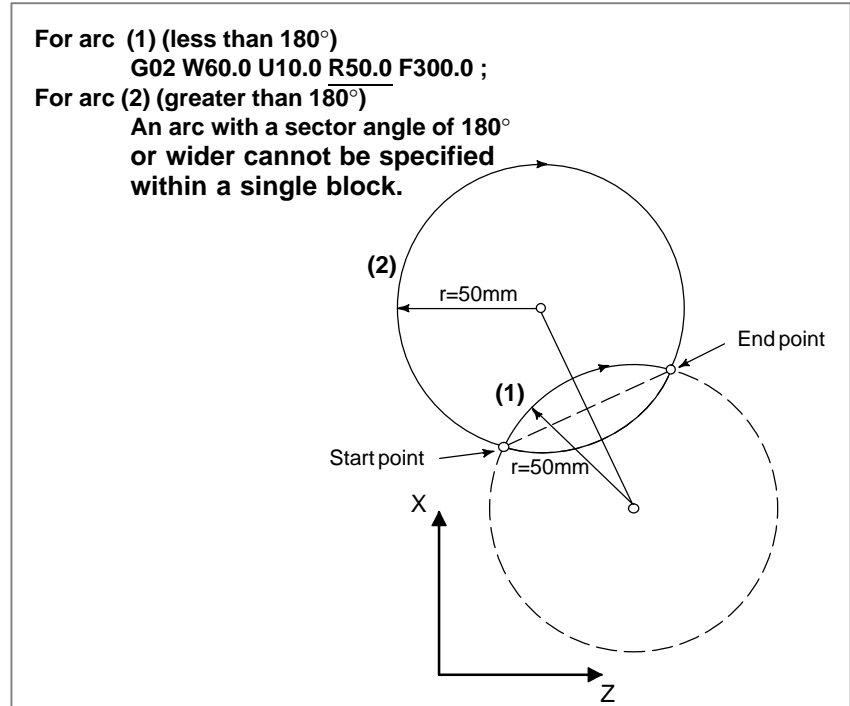

● **Arc radius R with nine digits (option)**

When the option for specifying arc radius R with nine digits is selected, the valid radius range for circular interpolation is expanded as follows:

		Input increments	
		Metric input	Inch input
Increment system	IS-B	0.001 to 999999.999 mm	0.0001 to 99999.9999 inch
	IS-C	0.0001 to 99999.9999 mm	0.00001 to 9999.99999 inch

NOTE

When using the nine-digit arc radius R function, note the following points.

- 1 Specifying an arc center with addresses I, K, and J
When the distance from the arc start point to the arc center is specified with addresses I, K, and J, a P/S alarm (No. 5059) is issued if:

$$\text{Maximum value which can be specified} < \sqrt{I^2 + K^2}$$

Example: When IS-B and metric input are selected, issuing the following command (radius specification) will result in a P/S alarm (No. 5059):

```
G50 X0 Z0;
G18G02X11.250 Z10. I-800000.000 K900000.000 F5.0;
```

$$\begin{aligned} \because \sqrt{I^2 + K^2} &= \sqrt{(-800000.000)^2 + 900000.000^2} \\ &= 1204159.458 \\ &> 999999.999 \end{aligned}$$

- 2 Tool nose radius compensation

In tool nose radius compensation mode, a P/S alarm (No. 5059) is issued if the distance from the tool nose radius center to the arc center exceeds the maximum value which can be specified.

- **Feedrate**

The feedrate in circular interpolation is equal to the feed rate specified by the F code, and the feedrate along the arc (the tangential feedrate of the arc) is controlled to be the specified feedrate.

The error between the specified feedrate and the actual tool feedrate is $\pm 2\%$ or less. However, this feed rate is measured along the arc after the tool nose radius compensation is applied.

Restrictions

- **Simultaneously specifying R with I, J, and K**
- **Specifying an axis that is not contained in the specified plane**
- **Difference in the radius between the start and end points**

If I, J, K, and R addresses are specified simultaneously, the arc specified by address R takes precedence and the other are ignored.

If an axis not contained in the specified plane is commanded, an alarm is displayed.

For example, when a ZX plane is specified in G-code B or C, specifying the X-axis or U-axis (parallel to the X-axis) causes P/S alarm No. 028 to be generated.

If the difference in the radius between the start and end points of the arc exceeds the value specified in parameter No. 3410, P/S alarm No. 020 is generated.

If the end point is not on the arc, the tool moves in a straight line along one of the axes after reaching the end point.

● **Specifying a semicircle with R**

If an arc having a central angle approaching 180° is specified with R, the calculation of the center coordinates may produce an error. In such a case, specify the center of the arc with I, J, and K.

Examples

● **Command of circular interpolation X, Z**

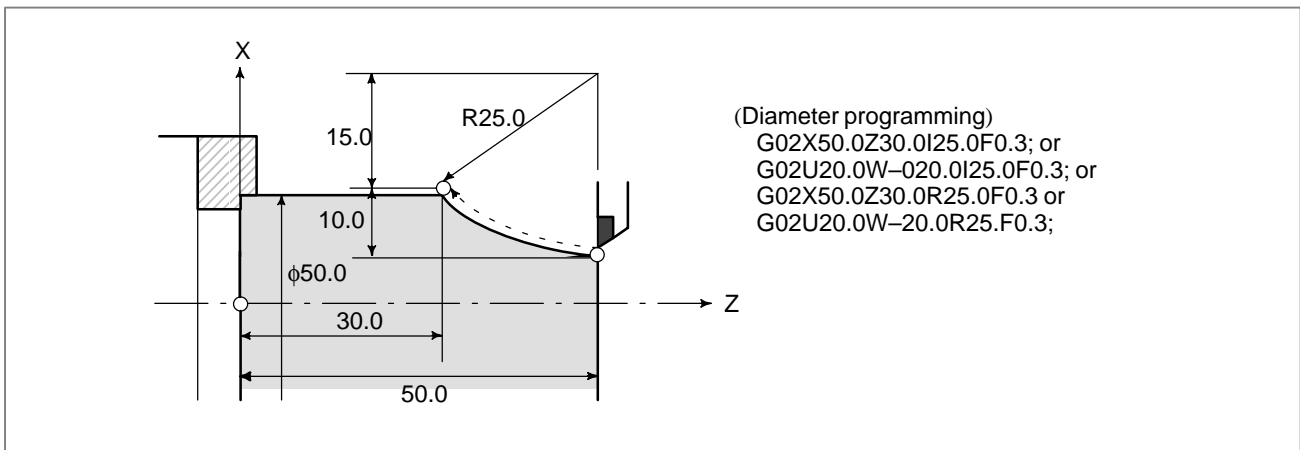
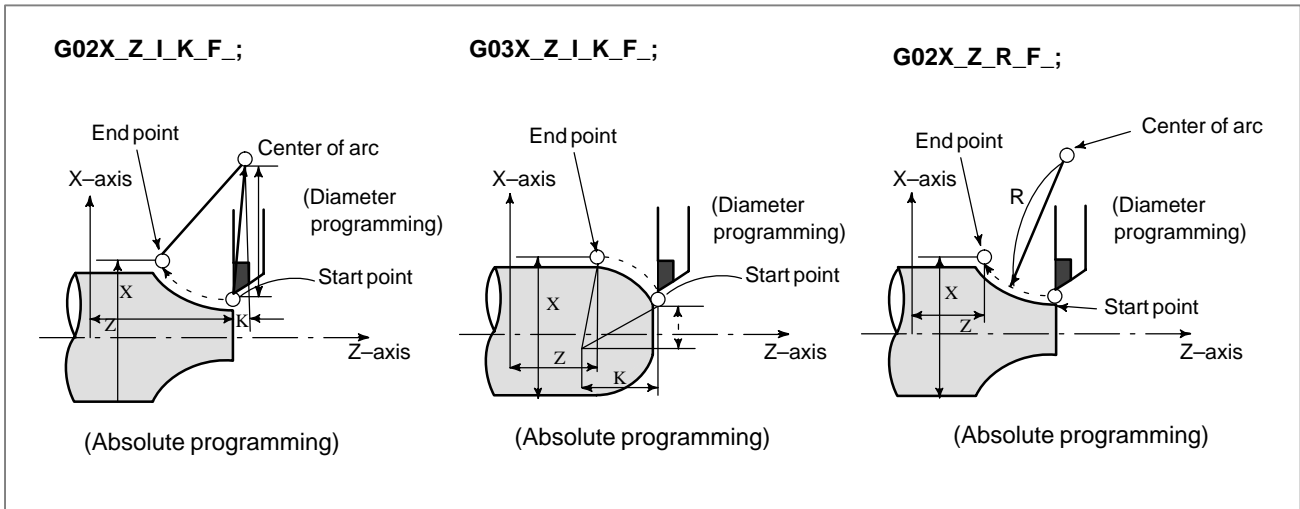

4.5 HELICAL INTERPOLATION (G02, G03)

Format

Helical interpolation which moved helically is enabled by specifying up to two other axes which move synchronously with the circular interpolation by circular commands.

Synchronously with arc of XpYp plane

$$G17 \left\{ \begin{array}{l} G02 \\ G03 \end{array} \right\} Xp_Yp_ \left\{ \begin{array}{l} I_J_ \\ R_ \end{array} \right\} \alpha_(\beta_)F_;$$

Synchronously with arc of ZpXp plane

$$G18 \left\{ \begin{array}{l} G02 \\ G03 \end{array} \right\} Xp_Zp_ \left\{ \begin{array}{l} I_K_ \\ R_ \end{array} \right\} \alpha_(\beta_)F_;$$

Synchronously with arc of YpZp plane

$$G19 \left\{ \begin{array}{l} G02 \\ G03 \end{array} \right\} Yp_Zp_ \left\{ \begin{array}{l} J_K_ \\ R_ \end{array} \right\} \alpha_(\beta_)F_;$$

α, β : Any one axis where circular interpolation is not applied.
Up to two other axes can be specified.

Explanations

The command method is to simply or secondary add a move command axis which is not circular interpolation axes. An F command specifies a feed rate along a circular arc. Therefore, the feed rate of the linear axis is as follows:

$$F_x \frac{\text{Length of linear axis}}{\text{Length of circular arc}}$$

Determine the feed rate so the linear axis feed rate does not exceed any of the various limit values. Bit 0 (HFC) of parameter No. 1404 can be used to prevent the linear axis feedrate from exceeding various limit values.

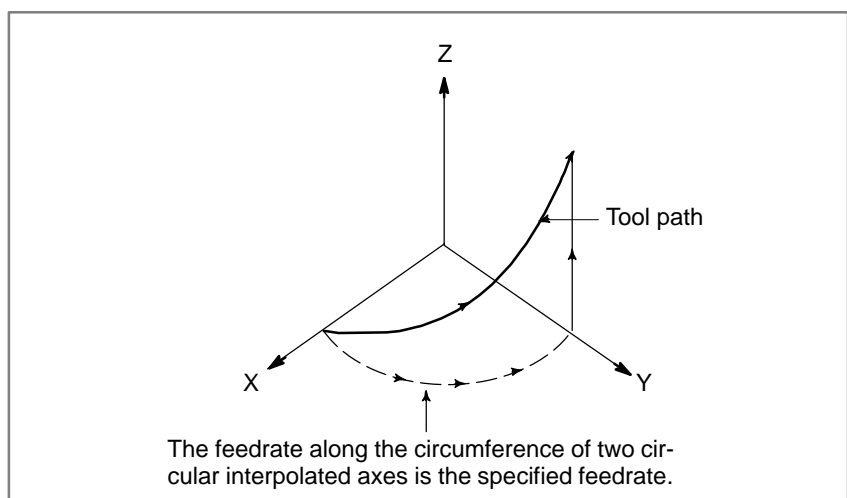

Limitations

- Tool nose radius compensation is applied only for a circular arc.
- Tool offset and tool length compensation cannot be used in a block in which a helical interpolation is commanded.

4.6 POLAR COORDINATE INTERPOLATION (G12.1, G13.1)

Polar coordinate interpolation is a function that exercises contour control in converting a command programmed in a Cartesian coordinate system to the movement of a linear axis (movement of a tool) and the movement of a rotary axis (rotation of a workpiece). This method is useful in cutting a front surface and grinding a cam shaft on a lathe.

Format

- Specify G12.1 and G13.1 in Separate Blocks.

G12.1 ;	Starts polar coordinate interpolation mode (enables polar coordinate interpolation)
	}
G13.1 ;	
	Polar coordinate interpolation mode is cancelled (for not performing polar coordinate interpolation)
	G112 and G113 can be used in place of G12.1 and G13.1, respectively.

Explanations

- Polar coordinate interpolation plane**

G12.1 starts the polar coordinate interpolation mode and selects a polar coordinate interpolation plane (Fig. 4.6 (a)). Polar coordinate interpolation is performed on this plane.

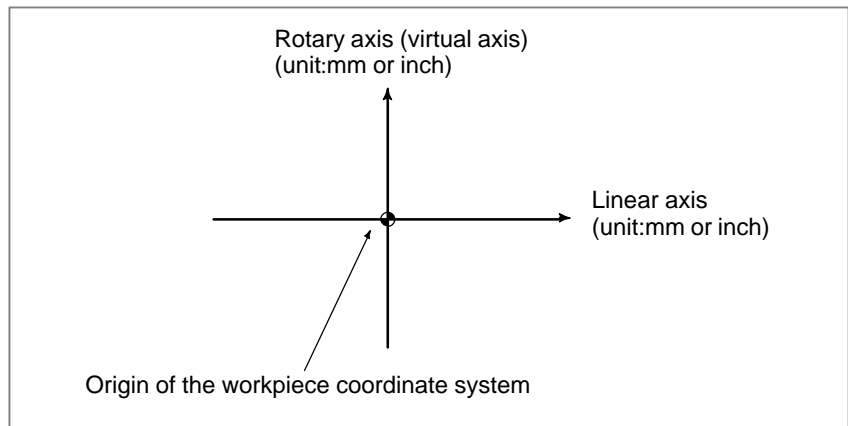

Fig. 4.6 (a) Polar coordinate interpolation plane.

When the power is turned on or the system is reset, polar coordinate interpolation is canceled (G13.1).

The linear and rotation axes for polar coordinate interpolation must be set in parameters (No. 5460 and 5461) beforehand.

CAUTION

The plane used before G12.1 is specified (plane selected by G17, G18, or G19) is canceled. It is restored when G13.1 (canceling polar coordinate interpolation) is specified. When the system is reset, polar coordinate interpolation is canceled and the plane specified by G17, G18, or G19 is used.

- **Distance moved and feedrate for polar coordinate interpolation**

The unit for coordinates on the hypothetical axis is the same as the unit for the linear axis (mm/inch)

The unit for the feedrate is mm/min or inch/min

- **G codes which can be specified in the polar coordinate interpolation mode**

In the polar coordinate interpolation mode, program commands are specified with Cartesian coordinates on the polar coordinate interpolation plane. The axis address for the rotation axis is used as the axis address for the second axis (virtual axis) in the plane. Whether a diameter or radius is specified for the first axis in the plane is the same as for the rotation axis regardless of the specification for the first axis in the plane. The virtual axis is at coordinate 0 immediately after G12.1 is specified. Polar interpolation is started assuming the angle of 0 for the position of the tool when G12.1 is specified.

Specify the feedrate as a speed (relative speed between the workpiece and tool) tangential to the polar coordinate interpolation plane (Cartesian coordinate system) using F.

G01 Linear interpolation

G02, G03 Circular interpolation

G04 Dwell

G40, G41, G42 Tool nose radius compensation

(Polar coordinate interpolation is applied to the path after cutter compensation.)

G65, G66, G67 Custom macro command

G98, G99 Feed per minute, feed per revolution

- **Circular interpolation in the polar coordinate plane**

The addresses for specifying the radius of an arc for circular interpolation (G02 or G03) in the polar coordinate interpolation plane depend on the first axis in the plane (linear axis).

- I and J in the X_p-Y_p plane when the linear axis is the X-axis or an axis parallel to the X-axis.
- J and K in the Y_p-Z_p plane when the linear axis is Y-axis or an axis parallel to the Y-axis.
- K and I in the Z_p-X_p plane when the linear axis is the Z-axis or an axis parallel to the Z-axis.

The radius of an arc can be specified also with an R command.

NOTE

The U-, V-, and W-axes (parallel with the basic axis) can be used with G-codes B and C.

- **Movement along axes not in the polar coordinate interpolation plane in the polar coordinate interpolation mode**

The tool moves along such axes normally, independent of polar coordinate interpolation.

- **Current position display in the polar coordinate interpolation mode**

Actual coordinates are displayed. However, the remaining distance to move in a block is displayed based on the coordinates in the polar coordinate interpolation plane (Cartesian coordinates).

Restrictions

- **Coordinate system for the polar coordinate interpolation**
Before G12.1 is specified, a workpiece coordinate system) where the center of the rotary axis is the origin of the coordinate system must be set. In the G12.1 mode, the coordinate system must not be changed (G92, G52, G53, relative coordinate reset, G54 through G59, etc.).
- **Tool nose radius compensation command**
The polar coordinate interpolation mode cannot be started or terminated (G12.1 or G13.1) in the tool nose radius compensation mode (G41 or G42). G12.1 or G13.1 must be specified in the tool nose radius compensation canceled mode (G40).
- **Program restart**
For a block in the G12.1 mode, the program cannot be restarted.
- **Cutting feedrate for the rotation axis**
Polar coordinate interpolation converts the tool movement for a figure programmed in a Cartesian coordinate system to the tool movement in the rotation axis (C-axis) and the linear axis (X-axis). When the tool moves closer to the center of the workpiece, the C-axis component of the feedrate becomes larger and may exceed the maximum cutting feedrate for the C-axis (set in parameter (No. 1422)), causing an alarm (see the figure below). To prevent the C-axis component from exceeding the maximum cutting feedrate for the C-axis, reduce the feedrate specified with address F or create a program so that the tool (center of the tool when tool nose radius compensation is applied) does not move close to the center of the workpiece.

WARNING

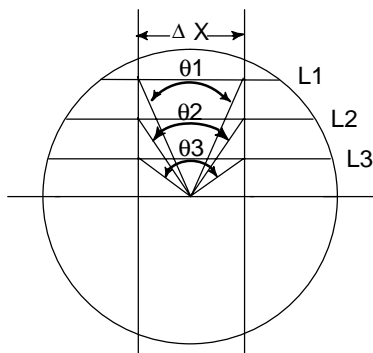

Consider lines L1, L2, and L3. ΔX is the distance the tool moves per time unit at the feedrate specified with address F in the Cartesian coordinate system. As the tool moves from L1 to L2 to L3, the angle at which the tool moves per time unit corresponding to ΔX in the Cartesian coordinate system increases from θ_1 to θ_2 to θ_3 .

In other words, the C-axis component of the feedrate becomes larger as the tool moves closer to the center of the workpiece. The C component of the feedrate may exceed the maximum cutting feedrate for the C-axis because the tool movement in the Cartesian coordinate system has been converted to the tool movement for the C-axis and the X-axis.

L : Distance (in mm) between the tool center and workpiece center when the tool center is the nearest to the workpiece center

R : Maximum cutting feedrate (deg/min) of the C axis

Then, a speed specifiable with address F in polar coordinate interpolation can be given by the formula below. Specify a speed allowed by the formula. The formula provides a theoretical value; in practice, a value slightly smaller than a theoretical value may need to be used due to a calculation error.

$$F < L \times R \times \frac{\pi}{180} \text{ (mm/min)}$$

- **Diameter and radius programming**
Even when diameter programming is used for the linear axis (X-axis), radius programming is applied to the rotary axis (C-axis).

Examples

Example of Polar Coordinate Interpolation Program Based on X Axis (Linear Axis) and C Axis (Rotary Axis)

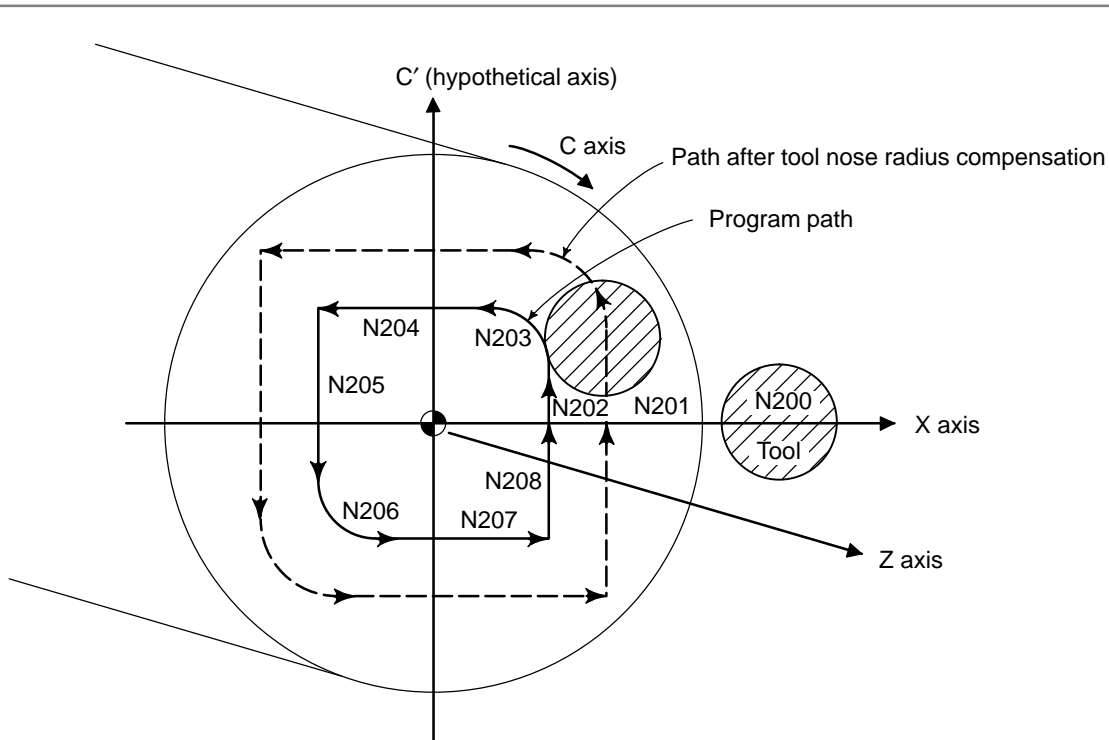

X axis is by diameter programming, C axis is by radius programming.

```

O0001 ;
  ⋮
N010 T0101
  ⋮
N0100 G00 X120.0 C0 Z _ ;
N0200 G12.1 ;
N0201 G42 G01 X40.0 F _ ;
N0202 C10.0 ;
N0203 G03 X20.0 C20.0 R10.0 ;
N0204 G01 X-40.0 ;
N0205 C-10.0 ;
N0206 G03 X-20.0 C-20.0 I10.0 J0 ;
N0207 G01 X40.0 ;
N0208 C0 ;
N0209 G40 X120.0 ;
N0210 G13.1 ;
N0300 Z _ ;
N0400 X _ C _ ;
  ⋮
N0900M30 ;
    
```

Positioning to start position

Start of polar coordinate interpolation

Geometry program

(program based on cartesian coordinates on X-C' plane)

Cancellation of polar coordinate interpolation

4.7 CYLINDRICAL INTERPOLATION (G07.1)

The amount of travel of a rotary axis specified by an angle is once internally converted to a distance of a linear axis along the outer surface so that linear interpolation or circular interpolation can be performed with another axis. After interpolation, such a distance is converted back to the amount of travel of the rotary axis.

The cylindrical interpolation function allows the side of a cylinder to be developed for programming. So programs such as a program for cylindrical cam grooving can be created very easily.

Format

**G07.1 IP r ; Starts the cylindrical interpolation mode
(enables cylindrical interpolation).**

⋮

G07.1 IP 0 ; The cylindrical interpolation mode is cancelled.

**IP : An address for the rotation axis
r : Radius value of the cylinder**

**Specify G07.1 IP r ; and G07.1 IP 0; in separate blocks.
G107 can be used instead of G07.1.**

Explanations

- **Plane selection
(G17, G18, G19)**

Use parameter No. 1002 to specify whether the rotation axis is the X-, Y-, or Z-axis, or an axis parallel to one of these axes. Specify the G code to select a plane for which the rotation axis is the specified linear axis.

For example, when the rotation axis is an axis parallel to the X-axis, G17 must specify an Xp-Yp plane, which is a plane defined by the rotation axis and the Y-axis or an axis parallel to the Y-axis.

Only one rotation axis can be set for cylindrical interpolation.

NOTE

The U-, V-, and W-axes (parallel with the basic axis) can be used with G-codes B and C.

- **Feedrate**

A feedrate specified in the cylindrical interpolation mode is a speed on the developed cylindrical surface.

- **Circular interpolation (G02,G03)**

In the cylindrical interpolation mode, circular interpolation is possible with the rotation axis and another linear axis. Radius R is used in commands in the same way as described in Section 4.4.

The unit for a radius is not degrees but millimeters (for metric input) or inches (for inch input).

< Example Circular interpolation between the Z axis and C axis >

For the C axis of parameter No. 1022, 5 (axis parallel with the X axis) is to be set. In this case, the command for circular interpolation is

```
G18 Z__C__;  
G02 (G03) Z__C__R__;
```

For the C axis of parameter No. 1022, 6 (axis parallel with the Y axis) may be specified instead. In this case, however, the command for circular interpolation is

```
G19 C__Z__;  
G02 (G03) Z__C__R__;
```

- **Tool nose radius compensation**

To perform tool nose radius compensation in the cylindrical interpolation mode, cancel any ongoing tool nose radius compensation mode before entering the cylindrical interpolation mode. Then, start and terminate tool nose radius compensation within the cylindrical interpolation mode.

- **Cylindrical interpolation accuracy**

In the cylindrical interpolation mode, the amount of travel of a rotary axis specified by an angle is once internally converted to a distance of a linear axis on the outer surface so that linear interpolation or circular interpolation can be performed with another axis. After interpolation, such a distance is converted back to an angle. For this conversion, the amount of travel is rounded to a least input increment.

So when the radius of a cylinder is small, the actual amount of travel can differ from a specified amount of travel. Note, however, that such an error is not accumulative.

If manual operation is performed in the cylindrical interpolation mode with manual absolute on, an error can occur for the reason described above.

$$\text{The actual amount of travel} = \left[\frac{\text{MOTION REV}}{2 \times 2\pi R} \left[\times \text{Specified value} \times \frac{2 \times 2\pi R}{\text{MOTION REV}} \right] \right]$$

MOTION REV : The amount of travel per rotation of the rotation axis (Setting value of parameter No. 1260)

R : Workpiece radius

$\left[\right]$: Rounded to the least input increment

Restrictions

- **Arc radius specification in the cylindrical interpolation mode**

In the cylindrical interpolation mode, an arc radius cannot be specified with word address I, J, or K.

- **Circular interpolation and tool nose radius compensation**

If the cylindrical interpolation mode is started when tool nose radius compensation is already applied, circular interpolation is not correctly performed in the cylindrical interpolation mode.

-
- **Positioning**

In the cylindrical interpolation mode, positioning operations (including those that produce rapid traverse cycles such as G28, G80 through G89) cannot be specified. Before positioning can be specified, the cylindrical interpolation mode must be cancelled. Cylindrical interpolation (G07.1) cannot be performed in the positioning mode (G00).
 - **Coordinate system setting**

In the cylindrical interpolation mode, a workpiece coordinate system G50 cannot be specified.
 - **Cylindrical interpolation mode setting**

In the cylindrical interpolation mode, the cylindrical interpolation mode cannot be reset. The cylindrical interpolation mode must be cancelled before the cylindrical interpolation mode can be reset.
 - **Canned cycle for drilling during cylindrical interpolation mode**

Canned cycles for drilling, G81 to G89, cannot be specified during cylindrical interpolation mode.
 - **Mirror Image for Double Turret**

Mirror image for double turret, G68 and G69, cannot be specified during cylindrical interpolation mode.

Examples

Example of a Cylindrical Interpolation Program

```

O0001 (CYLINDRICAL INTERPOLATION);
N01 G00 Z100.0 C0;
N02 G01 G18 W0 H0;
N03 G07.1 H57299;
N04 G01 G42 Z120.0 D01 F250;
N05 C30.0;
N06 G02 Z90.0 C60.0 R30.0;
N07 G01 Z70.0;
N08 G03 Z60.0 C70.0 R10.0;
N09 G01 C150.0;
N10 G03 Z70.0 C190.0 R75.0;
N11 G01 Z110.0 C230.0;
N12 G02 Z120.0 C270.0 R75.0;
N13 G01 C360.0;
N14 G40 Z100.0;
N15 G07.1 C0;
N16 M30;
    
```

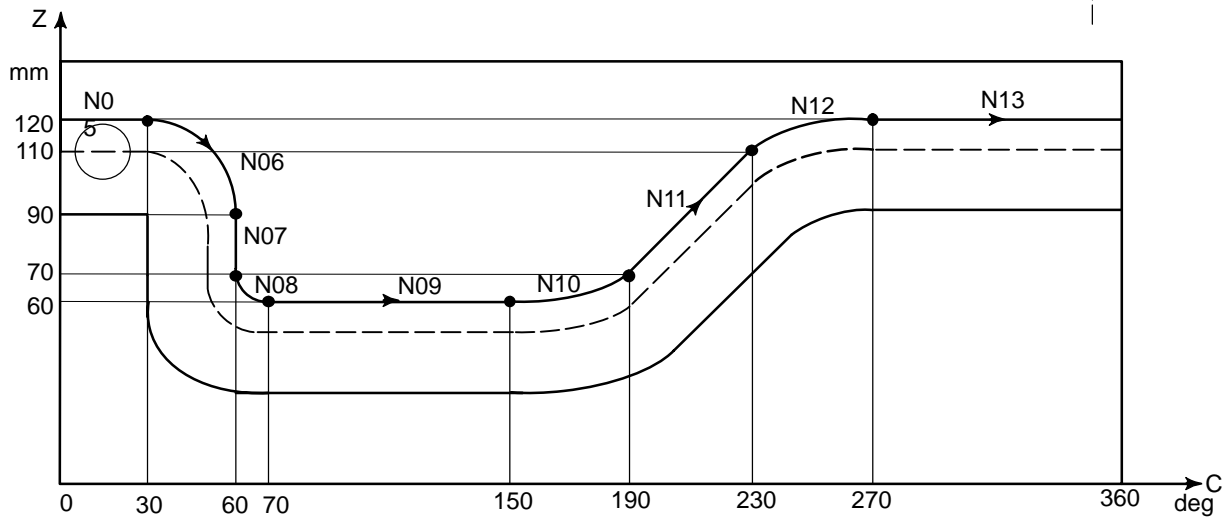
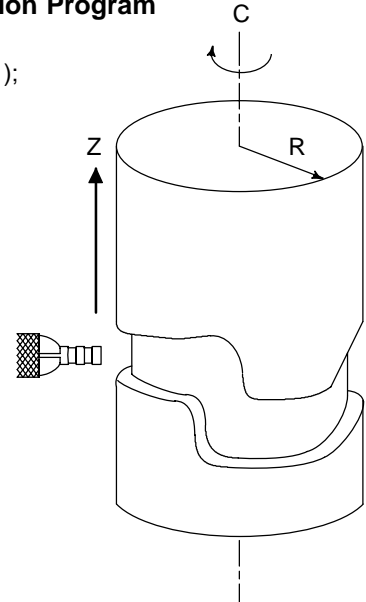

4.8 HYPOTHETICAL AXIS INTERPOLATION (G07)

In helical interpolation, when pulses are distributed with one of the circular interpolation axes set to a hypothetical axis, sine interpolation is enable.

When one of the circular interpolation axes is set to a hypothetical axis, pulse distribution causes the speed of movement along the remaining axis to change sinusoidally. If the major axis for threading (the axis along which the machine travels the longest distance) is set to a hypothetical axis, threading with a fractional lead is enabled. The axis to be set as the hypothetical axis is specified with G07.

Format

G07 α 0; Hypothetical axis setting

G07 α 1; Hypothetical axis cancel

Where, α is any one of the addresses of the controlled axes.

Explanations

- **Sine interpolation**

The α axis is regarded as a hypothetical axis for the period of time from the G07 α 0 command until the G07 α 1 command appears.

Suppose sine interpolation is performed for one cycle in the YZ plane. The hypothetical axis is then the X axis.

$$X^2 + Y^2 = r^2 \text{ (r is the radius of an arc.)}$$

$$Y = r \text{ SIN } \left(\frac{2\pi}{1} Z \right)$$

1 is the distance traveled along the Z-axis in one cycle.)

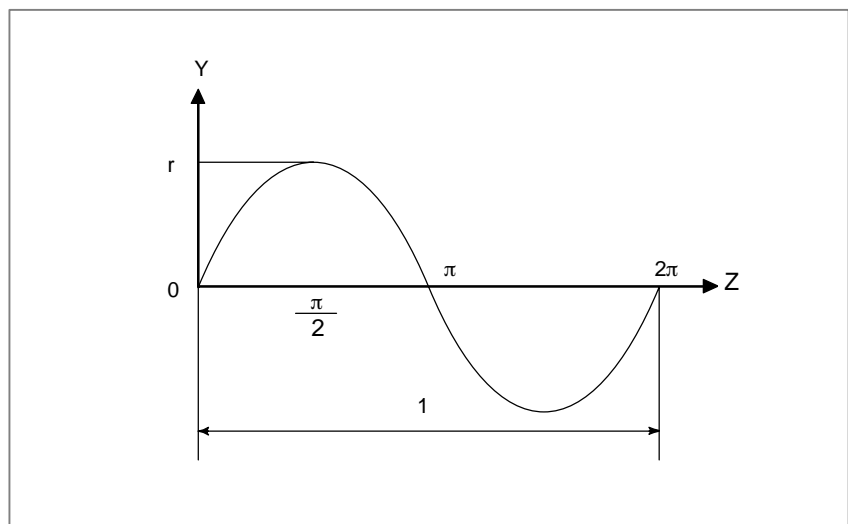

- **Interlock, stroke limit, and external deceleration**

Interlock, stroke limit, and external deceleration can also apply to the hypothetical axis.

- **Handle interrupt**

An interrupt caused by the handle also applies to the hypothetical axis. This means that movement for a handle interrupt is performed.

Limitations

- **Manual operation**
- **Move command**
- **Coordinate rotation**

The hypothetical axis can be used only in automatic operation. In manual operation, it is not used, and movement takes place.

Specify hypothetical axis interpolation only in the incremental mode.

Hypothetical axis interpolation does not support coordinate rotation.

Examples

- **Sine interpolation**

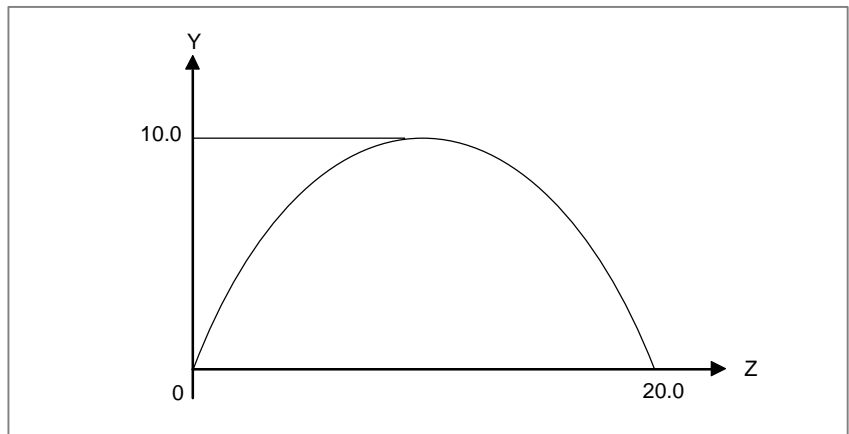

```
N001 G07 X0 ;
N002 G91 G17 G03 X-20.0 Y0.0 I-10.0 Z20.0 F100 ;
N003 G01 X10.0 ;
N004 G07 X1 ;
```

From the N002 to N003 blocks, the X-axis is set to a hypothetical axis. The N002 block specifies helical cutting in which the Z-axis is the linear axis. Since no movement takes place along the X axis, movement along the Y-axis is performed while performing sine interpolation along the Z-axis.

In the N003 block, there is no movement along the X-axis, and so the machine dwells until interpolation terminates.

- **Changing the feedrate to form a sine curve**

(Sample program)

```
G07Z0 ;           The Z-axis is set to a hypothetical axis.
G02X0Z0I10.0F4. ; The feedrate on the X-axis changes sinusoidally.
G07Z1 ;           The use of the Z-axis as a hypothetical axis is
                  canceled.
```

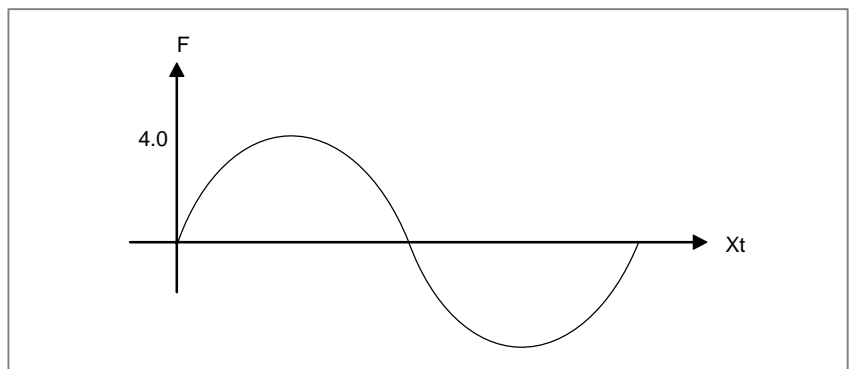

4.9 CONSTANT LEAD THREADING (G32)

Tapered screws and scroll threads in addition to equal lead straight threads can be cut by using a G32 command.

The spindle speed is read from the position coder on the spindle in real time and converted to a cutting feedrate for feed-per minute mode, which is used to move the tool.

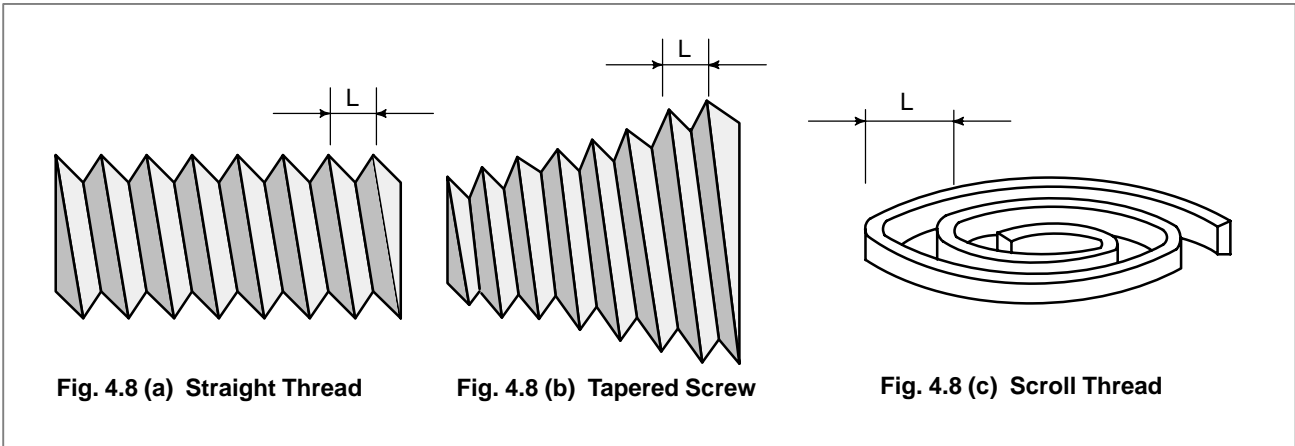

Format

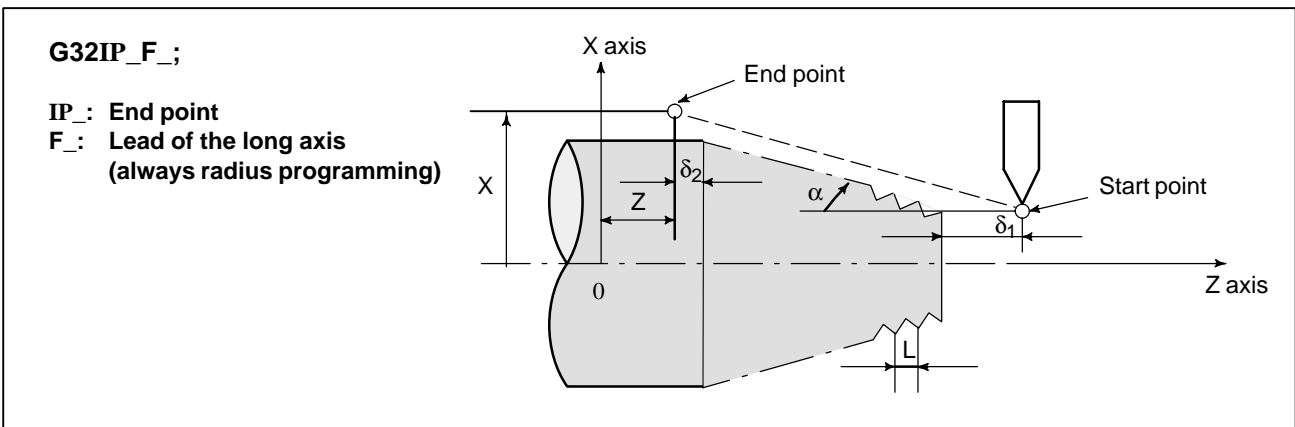

Fig. 4.9 (d) Example of Thread Cutting

Explanations

In general, thread cutting is repeated along the same tool path in rough cutting through finish cutting for a screw. Since thread cutting starts when the position coder mounted on the spindle outputs a 1-turn signal, threading is started at a fixed point and the tool path on the workpiece is unchanged for repeated thread cutting. Note that the spindle speed must remain constant from rough cutting through finish cutting. If not, incorrect thread lead will occur.

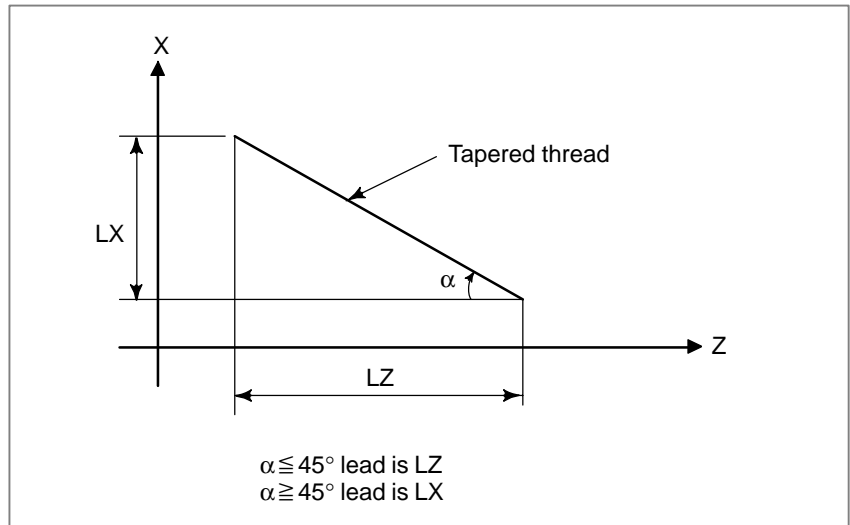

Fig. 4.9 (e) LZ and LX of a Tapered Thread

In general, the lag of the servo system, etc. will produce somewhat incorrect leads at the starting and ending points of a thread cut. To compensate for this, a threading length somewhat longer than required should be specified.

Table 4.9 lists the ranges for specifying the thread lead.

Table. 4.9 Ranges of lead sizes that can be specified

	Least command increment
mm input	0.0001 to 500.0000mm
Inch input	0.000001 inch to 9.999999inch

Explanations

1. Straight thread cutting

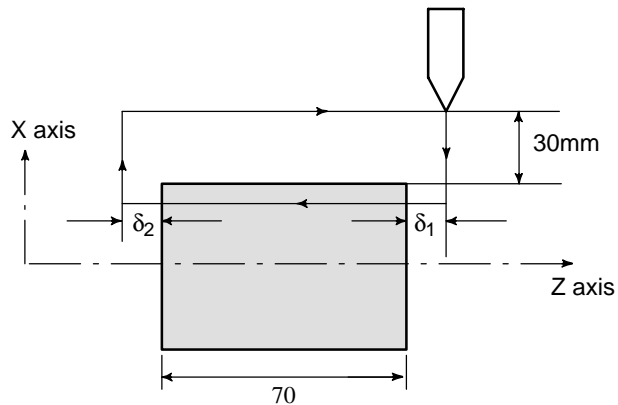

The following values are used in programming :
 Thread lead :4mm
 $\delta_1=3\text{mm}$
 $\delta_2=1.5\text{mm}$
 Depth of cut :1mm (cut twice)
 (Metric input, Diameter programming)

```
G00 U-62.0 ;
G32 W-74.5 F4.0 ;
G00 U62.0 ;
W74.5 ;
U-64.0 ;
(For the second cut, cut 1mm more)
G32 W-74.5 ;
G00 U64.0 ;
W74.5 ;
```

2. Tapered thread cutting

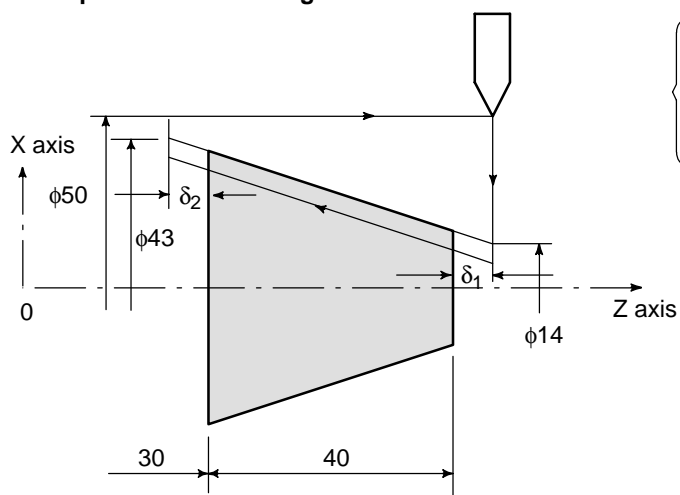

The following values are used in programming :
 Thread lead : 3.5mm in the direction of the Z axis
 $\delta_1=2\text{mm}$
 $\delta_2=1\text{mm}$
 Cutting depth in the X axis direction is 1mm
 (Cut twice)
 (Metric input, Diameter programming)

```
G00 X 12.0 Z72.0 ;
G32 X 41.0 Z29.0 F3.5 ;
G00 X 50.0 ;
Z 72.0 ;
X 10.0 ;
(Cut 1mm more for the second cut)
G32 X 39.0 Z29.0 ;
G00 X 50.0 ;
Z 72.0 ;
```

WARNING

- 1 Feedrate override is effective (fixed at 100%) during thread cutting.
- 2 It is very dangerous to stop feeding the thread cutter without stopping the spindle. This will suddenly increase the cutting depth. Thus, the feed hold function is ineffective while thread cutting. If the feed hold button is pressed during thread cutting, the tool will stop after a block not specifying thread cutting is executed as if the SINGLE BLOCK button were pushed. However, the feed hold lamp (SPL lamp) lights when the FEED HOLD button on the machine control panel is pushed. Then, when the tool stops, the lamp is turned off (Single Block stop status).
- 3 When the FEED HOLD button is held down, or is pressed again in the first block that does not specify thread cutting immediately after a thread cutting block, the tool stops at the block that does not specify thread cutting.
- 4 When thread cutting is executed in the single block status, the tool stops after execution of the first block not specifying thread cutting.
- 5 When the mode was changed from automatic operation to manual operation during thread cutting, the tool stops at the first block not specifying thread cutting as when the feed hold button is pushed as mentioned in Note 3.
However, when the mode is changed from one automatic operation mode to another, the tool stops after execution of the block not specifying thread cutting as for the single block mode in Note 4.
- 6 When the previous block was a thread cutting block, cutting will start immediately without waiting for detection of the 1-turn signal even if the present block is a thread cutting block.
`G32Z _ F_ ;`
`Z_ ;` (A 1-turn signal is not detected before this block.)
`G32 ;` (Regarded as threading block.)
`Z_ F_ ;` (One turn signal is also not detected.)
- 7 Because the constant surface speed control is effective during scroll thread or tapered screw cutting and the spindle speed changes, the correct thread lead may not be cut. Therefore, do not use the constant surface speed control during thread cutting. Instead, use G97.
- 8 A movement block preceding the thread cutting block must not specify chamfering or corner R.
- 9 A thread cutting block must not specify chamfering or corner R.
- 10 The spindle speed override function is disabled during thread cutting. The spindle speed is fixed at 100%.
- 11 Thread cycle retract function is ineffective to G32.

4.10 VARIABLE-LEAD THREAD CUTTING (G34)

Specifying an increment or a decrement value for a lead per screw revolution enables variable-lead thread cutting to be performed.

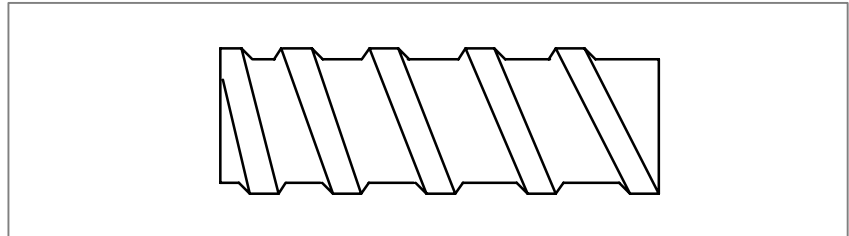

Fig. 4.10 Variable-lead screw

Format

G34 IP_F_K ;
IP : End point
F : Lead in longitudinal axis direction at the start point
K : Increment and decrement of lead per spindle revolution

Explanations

Address other than K are the same as in straight/taper thread cutting with G32.

Table 4.10 lists a range of values that can be specified as K.

Table 4.10 Range of valid K values

Metric input	± 0.0001 to ± 500.0000 mm/rev
Inch input	± 0.000001 to ± 9.999999 inch/rev

P/S alarm (No. 14) is produced, for example, when K such that the value in Table 4.10 is exceeded is directed, the maximum value of lead is exceeded as a result of increase or decrease by K or the lead has a negative value.

WARNING

The "Thread Cutting Cycle Retract" is not effective for G34.

Examples

Lead at the start point: 8.0 mm
 Lead increment: 0.3 mm/rev

G34 Z-72.0 F8.0 K0.3 ;

4.11 CONTINUOUS THREAD CUTTING

This function for continuous thread cutting is such that fractional pulses output to a joint between move blocks are overlapped with the next move for pulse processing and output (block overlap) .

Therefore, discontinuous machining sections caused by the interruption of move during continuously block machining are eliminated, thus making it possible to continuously direct the block for thread cutting instructions.

Explanations

Since the system is controlled in such a manner that the synchronism with the spindle does not deviate in the joint between blocks wherever possible, it is possible to performed special thread cutting operation in which the lead and shape change midway.



Fig. 4.11 Continuous Thread Cutting

Even when the same section is repeated for thread cutting while changing the depth of cut, this system allows a correct machining without impairing the threads.

NOTE

- 1 Block overlap is effective even for G01 command, producing a more excellent finishing surface.
- 2 When extreme micro blocks continue, no block overlap may function.

4.12 MULTIPLE-THREAD CUTTING

Using the Q address to specify an angle between the one-spindle-rotation signal and the start of threading shifts the threading start angle, making it possible to produce multiple-thread screws with ease.

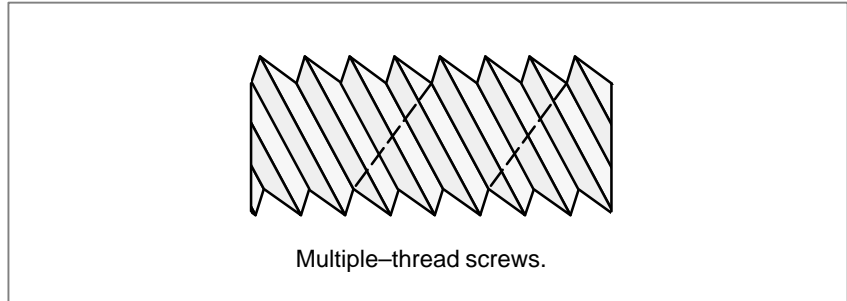

Format

(constant-lead threading)	
G32 IP_ F_ Q_ ;	IP_ : End point
G32 IP_ Q_ ;	F_ : Lead in longitudinal direction
	Q_ : Threading start angle

Explanations

- Available thread cutting commands

G32: Constant-lead thread cutting
 G34: Variable-lead thread cutting
 G76: Multiple-thread cutting cycle
 G92: Thread cutting cycle

Limitations

- Start angle

The start angle is not a continuous-state (modal) value. It must be specified each time it is used. If a value is not specified, 0 is assumed.

- Start angle increment

The start angle (Q) increment is 0.001 degrees. Note that no decimal point can be specified.

Example:

For a shift angle of 180 degrees, specify Q180000.

Q180.000 cannot be specified, because it contains a decimal point.

- Specifiable start angle range

A start angle (Q) of between 0 and 360000 (in 0.001-degree units) can be specified. If a value greater than 360000 (360 degrees) is specified, it is rounded down to 360000 (360 degrees).

- Multiple-thread cutting (G76)

For the G76 multiple-thread cutting command, always use the FS15 tape format.

Examples

**Program for producing double-threaded screws
(with start angles of 0 and 180 degrees)**

```
G00 X40.0 ;  
G32 W-38.0 F4.0 Q0 ;  
G00 X72.0 ;  
    W38.0 ;  
    X40.0 ;  
G32 W-38.0 F4.0 Q180000 ;  
G00 X72.0 ;  
    W38.0 ;
```

4.13 CIRCULAR THREADING (G35, G36)

Using the G35 and G36 commands, a circular thread, having the specified lead in the direction of the major axis, can be machined.

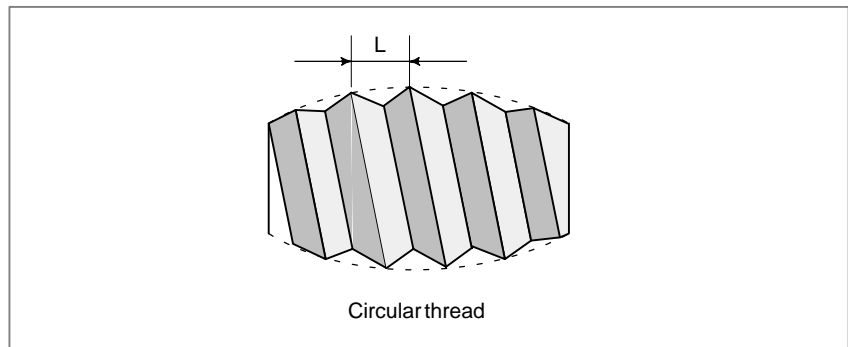

Format

$$\left\{ \begin{array}{l} \text{G35} \\ \text{G36} \end{array} \right\} X(U) _ Z(W) _ \left\{ \begin{array}{l} I _ K _ \\ R _ _ _ \end{array} \right\} F _ Q _ ;$$

G35 : Clockwise circular threading command

G36 : Counterclockwise circular threading command

X (U) : Specify the arc end point (in the same way as for G02, G03).

Z (W)

I, K : Specify the arc center relative to the start point, using relative coordinates (in the same way as for G02, G03).

R : Specify the arc radius.

F : Specify the lead in the direction of the major axis.

Q : Specify the shift of the threading start angle (0 to 360° in units of 0.001°)

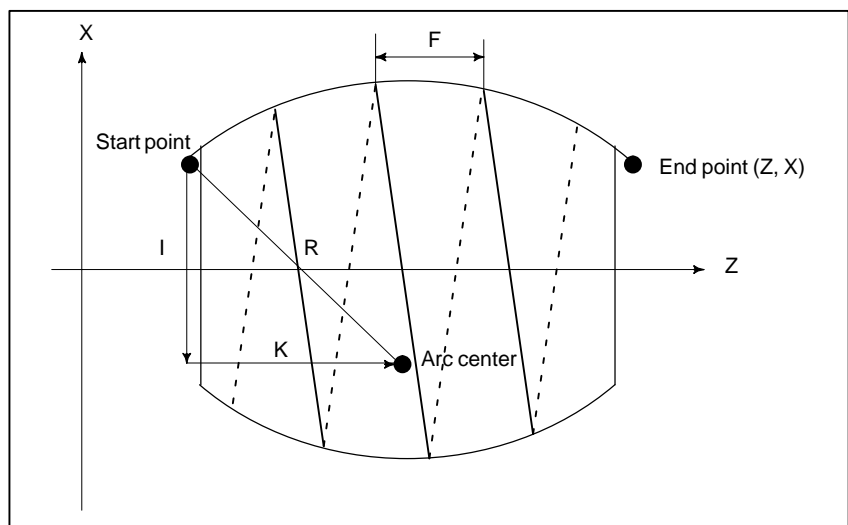

Explanations

- **Specifying the arc radius**
- **Selecting a plane other than the ZX plane**
- **Automatic tool compensation**

If R is specified with I and K, only R is effective.

If an additional axis other than the X- and Z-axes is provided, circular threading can be specified for a plane other than the ZX plane. The method of specification is the same as that for G02 and G03.

The G36 command is used to specify the following two functions: Automatic tool compensation X and counterclockwise circular threading. The function for which G36 is to be used depends on bit 3 (G36) of parameter No. 3405.

- When parameter G36 is set to 0, the G36 command is used for automatic tool compensation X.
- When parameter G36 is set to 1, the G36 command is used for counterclockwise circular threading.

G37.1 can be used to specify automatic tool compensation X and G37.2 can be used to specify automatic tool compensation Z.

(Specification method)

G37.1 X_

G37.2 Z_

G code when bit 3 of parameter No. 3405 is set to 1

G code	G code group	Function
G35	01	Clockwise circular threading
G36		Counterclockwise circular threading
G37	00	Automatic tool compensation Z
G37.1		Automatic tool compensation X
G37.2		Automatic tool compensation Z

Limitations

• **Range of specifiable arc**

An arc must be specified such that it falls within a range in which the major axis of the arc is always the Z-axis or always the X-axis, as shown in Fig. 4.13 (a) and (b). If the arc includes a point at which the major axis changes from the X-axis to Z-axis, or vice versa, as shown in Fig. 4.13 (c), P/S alarm 5058 is issued.

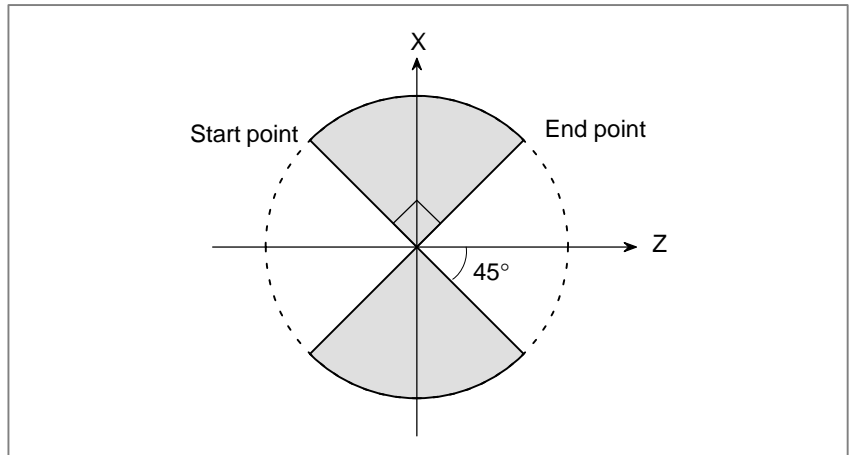

Fig. 4.13 (a) Range in which the Z-axis is the major axis

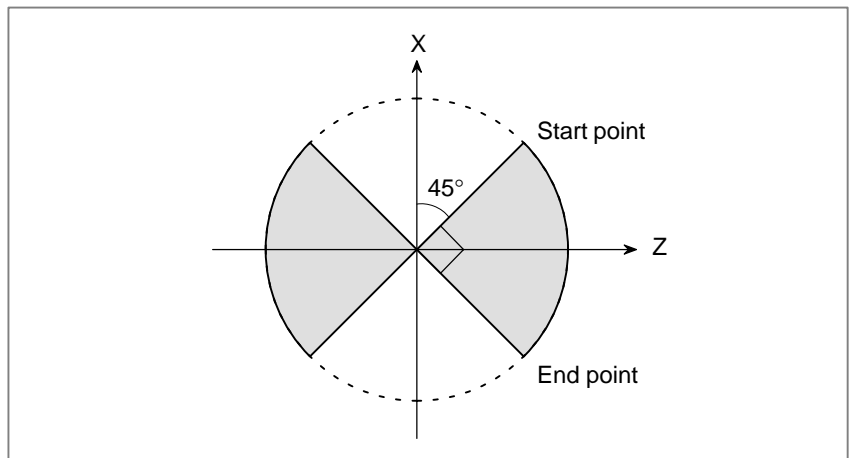

Fig. 4.13 (b) Range in which the X-axis is the major axis

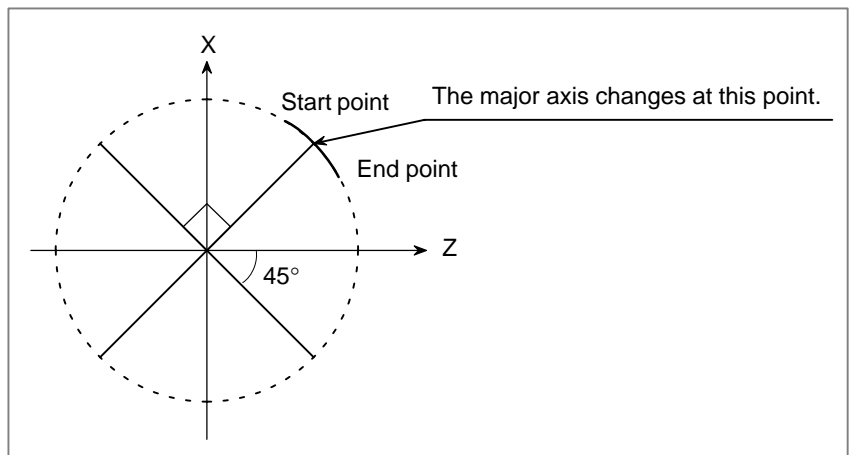

Fig. 4.13 (c) Example of arc specification which causes an alarm

4.14 SKIP FUNCTION (G31)

Linear interpolation can be commanded by specifying axial move following the G31 command, like G01. If an external skip signal is input during the execution of this command, execution of the command is interrupted and the next block is executed.

The skip function is used when the end of machining is not programmed but specified with a signal from the machine, for example, in grinding. It is used also for measuring the dimensions of a workpiece.

For details of how to use this function, refer to the manual supplied by the machine tool builder.

Format

G31 IP_ ;

G31: One-shot G code (If is effective only in the block in which it is specified)

Explanations

The coordinate values when the skip signal is turned on can be used in a custom macro because they are stored in the custom macro system variable #5061 to #5068, as follows:

```
#5061 X axis coordinate value
#5062 Z axis coordinate value
#5063 3rd axis coordinate value
:
:
#5068 8th axis coordinate value
```

WARNING

To increase the precision of the tool position when the skip signal is input, feedrate override, dry run, and automatic acceleration/deceleration is disabled for the skip function when the feedrate is specified as a feed per minute value. To enable these functions, set bit 7 (SKF) of parameter No. 6200 to 1. If the feedrate is specified as a feed per rotation value, feedrate override, dry run, and automatic acceleration/deceleration are enabled for the skip function, regardless of the setting of the SKF bit.

NOTE

- 1 If G31 command is issued while tool nose radius compensation is applied, an P/S alarm of No. 035 is displayed. Cancel the cutter compensation with the G40 command before the G31 command is specified.
- 2 For the high-speed skip option, executing G31 during feed-per-rotation mode causes P/S alarm (No. 211) to be generated.

Examples

- The next block to G31 is an incremental command

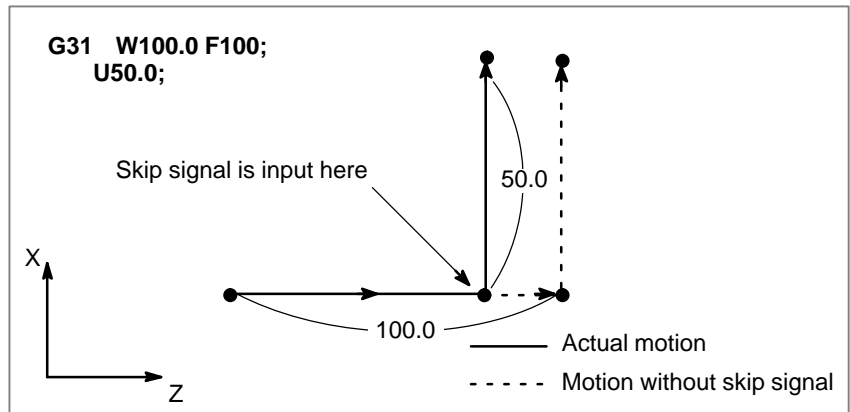

Fig.4.14 (a) The next block is an incremental command

- The next block to G31 is an absolute command for 1 axis

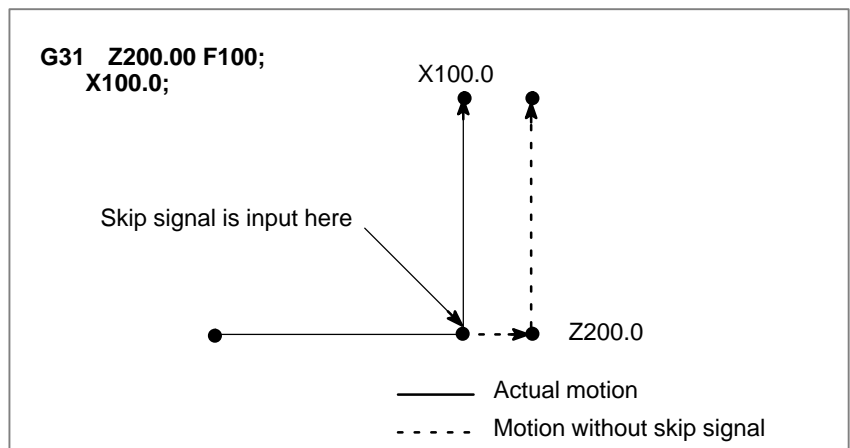

Fig.4.14 (b) The next block is an absolute command for 1 axis

- The next block to G31 is an absolute command for 2 axes

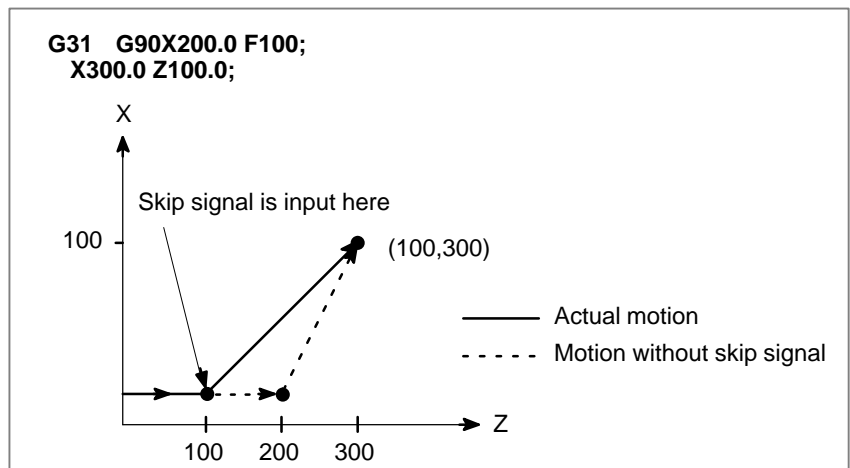

Fig 4.14 (c) The next block is an absolute command for 2 axes

4.15 MULTISTAGE SKIP (G31)

In a block specifying P1 to P4 after G31, the multistage skip function stores coordinates in a custom macro variable when a skip signal (4-point or 8-point ; 8-point when a high-speed skip signal is used) is turned on. Then, the function skips the entire amount of remaining movement. In a block specifying Q1 to Q4 after G04, the function skips a dwell when a skip signal (4-point or 8-point; 8-point when a high-speed skip signal is used) is turned on.

A skip signal from equipment such as a fixed-dimension size measuring instrument can be used to skip programs being executed.

In plunge grinding, for example, a series of operations from rough machining to spark-out can be performed automatically by applying a skip signal each time rough machining, semi-fine machining, fine-machining, or spark-out operation is completed.

For details of how to use this function, refer to the manuals supplied by the machine tool builder.

Format

Move command

G31 IP _ F _ P _ ;

IP_ : End point

F_ : Feedrate

P_ : P1-P4

Dwell

G04 X (U, P)_ (Q_) ;

X(U, P)_ : Dwell time

Q_ : Q1 - Q4

Explanations

Multistage skip is caused by specifying P1, P2, P3, or P4 in a G31 block. For an explanation of selecting (P1, P2, P3, or P4), refer to the manual supplied by the machine tool builder.

Specifying Q1, Q2, Q3, or Q4 in G04 (dwell command) enables dwell skip in a similar way to specifying G31. A skip may occur even if Q is not specified. For an explanation of selecting (Q1, Q2, Q3, or Q4), refer to the manual supplied by the machine tool builder.

- **Correspondence to skip signals**

Parameter Nos. 6202 to 6205 can be used to specify whether the 4-point or 8-point skip signal is used (when a high-speed skip signal is used). Specification is not limited to one-to-one correspondence. It is possible to specify that one skip signal correspond to two or more Pn's or Qn's (n=1, 2, 3, 4). Also, bits 0 (DS1) to 7 (DS8) of parameter No. 6206 can be used to specify dwell.

CAUTION

Dwell is not skipped when Qn is not specified and parameters DS1-DS8 (No. 6206#0-#7) are not set.

4.16 TORQUE LIMIT SKIP (G31 P99)

With the motor torque limited (for example, by a torque limit command, issued through the PMC window), a move command following G31 P99 (or G31 P98) can cause the same type of cutting feed as with G01 (linear interpolation).

With the issue of a signal indicating a torque limit has been reached (because of pressure being applied or for some other reason), a skip occurs.

For details of how to use this function, refer to the manuals supplied by the machine tool builder.

Format

G31 P99 IP_ F_ ;

G31 P98 IP_ F_ ;

G31: One-shot G code (G code effective only in the block in which it is issued)

Explanations

- **G31 P99**
If the motor torque limit is reached, or a SKIP signal is received during execution of G31 P99, the current move command is aborted, and the next block is executed.
- **G31 P98**
If the motor torque limit is reached during execution of G31 P98, the current move command is aborted, and the next block is executed. The SKIP signal <X0004#7/Tool post 2 X0013#7> does not affect G31 P98. Entering a SKIP signal during the execution of G31 P98 does not cause a skip.
- **Torque limit command**
If a torque limit is not specified before the execution of G31 P99/98, the move command continues; no skip occurs even if a torque limit is reached.
- **Custom macro system variable**
When G31 P99/98 is specified, the custom macro variables hold the coordinates at the end of a skip. (See Section 4.9.)
If a SKIP signal causes a skip with G31 P99, the custom macro system variables hold the coordinates based on the machine coordinate system when it stops, rather than those when the SKIP signal is entered.

Limitations

- **Axis command**
Only one axis can be controlled in each block with G31 P98/99. If two or more axes are specified to be controlled in such blocks, or no axis command is issued, P/S alarm No. 015 is generated.
- **Degree of servo error**
When a signal indicating that a torque limit has been reached is input during execution of G31 P99/98, and the degree of servo error exceeds 32767, P/S alarm No. 244 is generated.
- **High-speed skip**
With G31 P99, a SKIP signal can cause a skip, but not a high-speed skip.

- **Simplified synchronization and slanted axis control** G31 P99/98 cannot be used for axes subject to simplified synchronization or the X-axis or Z-axis when under slanted axis control.
- **Speed control** Bit 7 (SKF) of parameter No. 6200 must be set to disable dry run, override, and auto acceleration or deceleration for G31 skip commands.
- **Consecutive commands** Do not use G31 P99/98 in consecutive blocks.

WARNING

Always specify a torque limit before a G31 P99/98 command. Otherwise, G31 P99/98 allows move commands to be executed without causing a skip.

NOTE

If G31 is issued with tool nose radius compensation specified, P/S alarm No. 035 is generated. Therefore, before issuing G31, execute G40 to cancel tool nose radius compensation.

Examples

```

O0001 ;
:
:
:
M□□ ; ← The PMC specifies the torque limit
:           through the window.
:
:
G31 P99 X200. F100 ; ← Torque limit skip command
:
G01 X100. F500 ; ← Move command for which a torque
:           limit is applied
:
:
M△△ ; ← Torque limit canceled by the PMC
:
:
M30 ;
:
%
```

5 FEED FUNCTIONS



5.1 GENERAL

• Feed functions

The feed functions control the feedrate of the tool. The following two feed functions are available:

1. Rapid traverse

When the positioning command (G00) is specified, the tool moves at a rapid traverse feedrate set in the CNC (parameter No. 1420).

2. Cutting feed

The tool moves at a programmed cutting feedrate.

• Override

Override can be applied to a rapid traverse rate or cutting feedrate using the switch on the machine operator's panel.

• Automatic acceleration/ deceleration

To prevent a mechanical shock, acceleration/deceleration is automatically applied when the tool starts and ends its movement (Fig. 5.1 (a)).

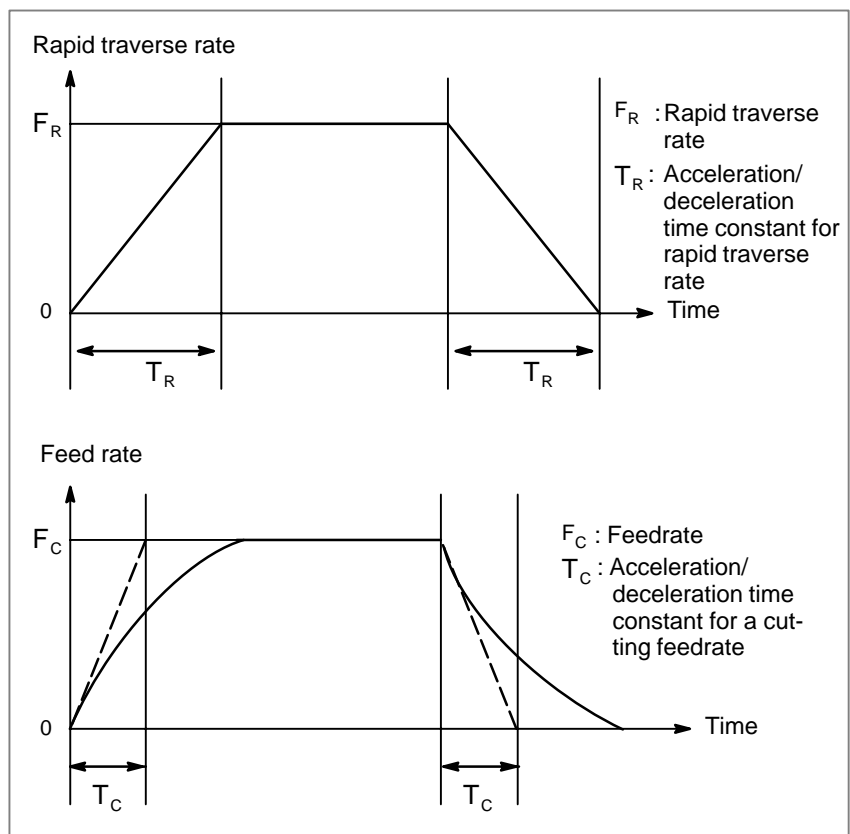

Fig. 5.1 (a) Automatic acceleration/deceleration (example)

- **Tool path in a cutting feed**

If the direction of movement changes between specified blocks during cutting feed, a rounded-corner path may result (Fig. 5.1 (b)).

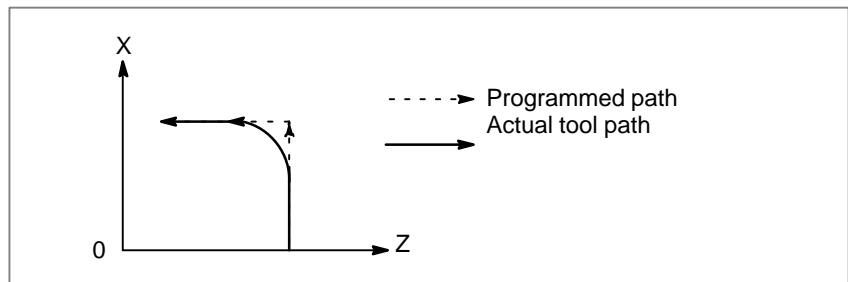

Fig. 5.1 (b) Example of Tool Path between Two Blocks

In circular interpolation, a radial error occurs (Fig. 5.1 (c)).

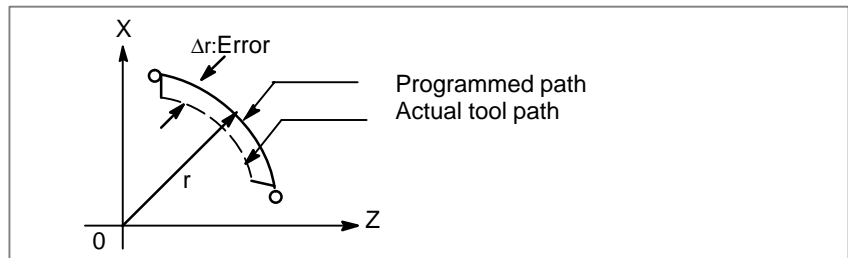

Fig. 5.1 (c) Example of Radial Error in Circular Interpolation

The rounded-corner path shown in Fig. 5.1 (b) and the error shown in Fig. 5.1 (c) depend on the feedrate. So, the feedrate needs to be controlled for the tool to move as programmed.

5.2 RAPID TRAVERSE

Format

```
G00 IP_ ;  
G00 : G code (group 01) for positioning (rapid traverse)  
IP_ ; Dimension word for the end point
```

Explanations

The positioning command (G00) positions the tool by rapid traverse. In rapid traverse, the next block is executed after the specified feedrate becomes 0 and the servo motor reaches a certain range set by the machine tool builder (in-position check).

A rapid traverse rate is set for each axis by parameter No. 1420, so no rapid traverse feedrate need be programmed.

The following overrides can be applied to a rapid traverse rate with the switch on the machine operator's panel:F0, 25, 50, 100%

F0: Allows a fixed feedrate to be set for each axis by parameter No. 1421. For detailed information, refer to the appropriate manual of the machine tool builder.

5.3 CUTTING FEED

Feedrate of linear interpolation (G01), circular interpolation (G02, G03), etc. are commanded with numbers after the F code.

In cutting feed, the next block is executed so that the feedrate change from the previous block is minimized.

Two modes of specification are available:

1. Feed per minute (G98)
After F, specify the amount of feed of the tool per minute.
2. Feed per revolution (G99)
After F, specify the amount of feed of the tool per spindle revolution.

Format

Feed per minute

G98 ; G code (group 05) for feed per minute

F_ ; Feedrate command (mm/min or inch/min)

Feed per revolution

G99 ; G code (group 05) for feed per revolution

F_ ; Feedrate command (mm/rev or inch/rev)

Explanations

- **Tangential speed constant control**

Cutting feed is controlled so that the tangential feedrate is always set at a specified feedrate.

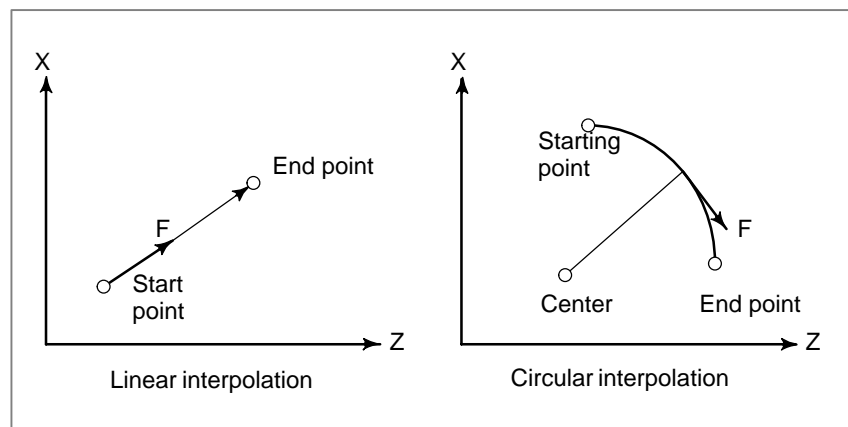

Fig. 5.3 (a) Tangential feedrate (F)

- **Feed per minute (G98)**

After specifying G98 (in the feed per minute mode), the amount of feed of the tool per minute is to be directly specified by setting a number after F. G98 is a modal code. Once a G98 is specified, it is valid until G99 (feed per revolution) is specified. At power-on, the feed per revolution mode is set.

An override from 0% to 254% (in 1% steps) can be applied to feed per minute with the switch on the machine operator's panel. For detailed information, see the appropriate manual of the machine tool builder.

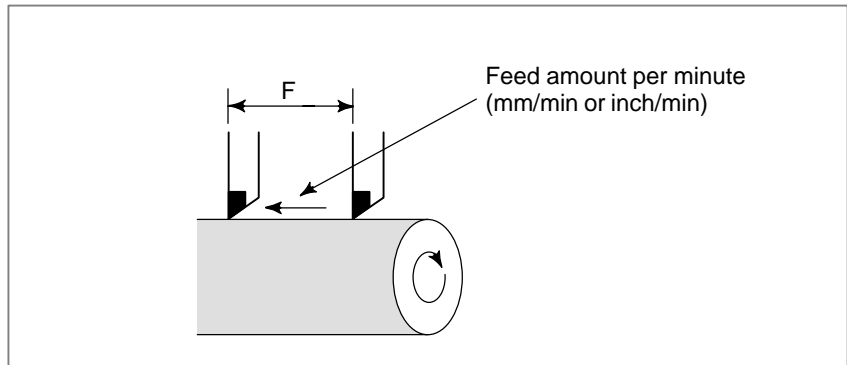

Fig. 5.3 (b) Feed per minute

WARNING

No override can be used for some commands such as for threading.

- **Feed per revolution (G99)**

After specifying G99 (in the feed per revolution mode), the amount of feed of the tool per spindle revolution is to be directly specified by setting a number after F. G99 is a modal code. Once a G99 is specified, it is valid until G98 (feed per minute) is specified.

An override from 0% to 254% (in 1% steps) can be applied to feed per revolution with the switch on the machine operator's panel. For detailed information, see the appropriate manual of the machine tool builder.

If bit 0 (NPC) of parameter No. 1402 has been set to 1, feed-per-rotation commands can be specified even when a position coder is not being used. (The CNC converts feed-per-rotation commands to feed-per-minute commands.)

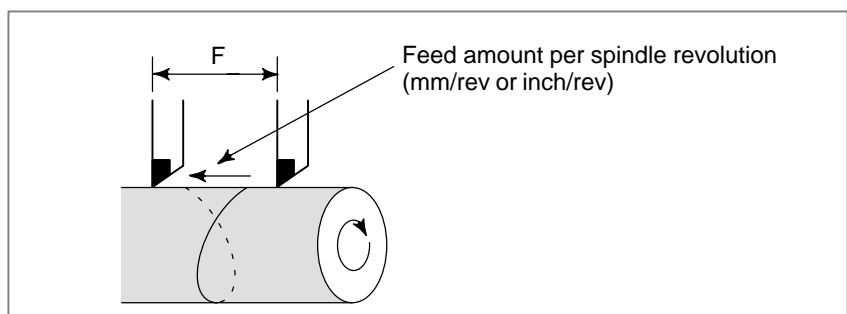

Fig. 5.3 (c) Feed per revolution

CAUTION

When the speed of the spindle is low, feedrate fluctuation may occur. The slower the spindle rotates, the more frequently feedrate fluctuation occurs.

- **Cutting feedrate clamp**

A common upper limit can be set on the cutting feedrate along each axis with parameter No. 1422. If an actual cutting feedrate (with an override applied) exceeds a specified upper limit, it is clamped to the upper limit.

NOTE

An upper limit is set in mm/min or inch/min. CNC calculation may involve a feedrate error of $\pm 2\%$ with respect to a specified value. However, this is not true for acceleration/deceleration. To be more specific, this error is calculated with respect to a measurement on the time the tool takes to move 500 mm or more during the steady state:

- **Reference**

See Appendix C for a range of feedrates that can be specified.

5.4 DWELL (G04)

Format

Dwell G04 X_ ; or G04 U_ ; or G04 P_ ;
 X_ : Specify a time (decimal point permitted)
 U_ : Specify a time (decimal point permitted)
 P_ : Specify a time (decimal point not permitted)

Explanations

By specifying a dwell, the execution of the next block is delayed by the specified time.

Bit 1 (DWL) of parameter No. 3405 can specify dwell for each rotation in feed per rotation mode (G99).

Table 5.4 (a)
Command value range of the dwell time (Command by X or U)

Increment system	Command value range	Dwell time unit
IS-B	0.001 to 99999.999	s or rev
IS-C	0.0001 to 9999.9999	

Table 5.4 (b)
Command value range of the dwell time (Command by P)

Increment system	Command value range	Dwell time unit
IS-B	1 to 99999999	0.001 s or rev
IS-C	1 to 99999999	0.0001 s or rev

6

REFERENCE POSITION



A CNC machine tool has a special position where, generally, the tool is exchanged or the coordinate system is set, as described later. This position is referred to as a reference position.

6.1 REFERENCE POSITION RETURN

- **Reference position**

The reference position is a fixed position on a machine tool to which the tool can easily be moved by the reference position return function. For example, the reference position is used as a position at which tools are automatically changed. Up to four reference positions can be specified by setting coordinates in the machine coordinate system in parameters (No. 1240 to 1243).

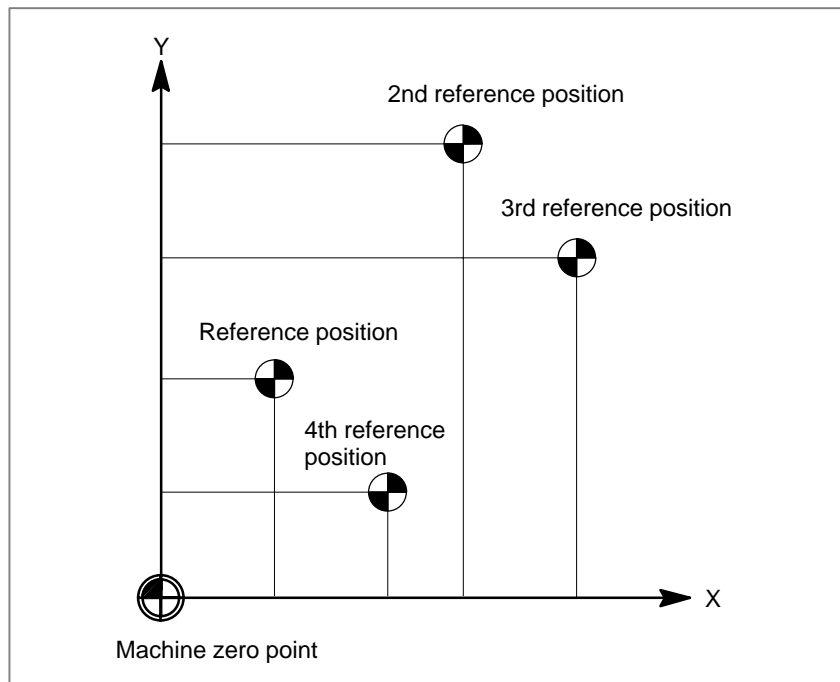

Fig. 6.1 (a) Machine zero point and reference positions

- **Reference position return**

Tools are automatically moved to the reference position via an intermediate position along a specified axis. When reference position return is completed, the lamp for indicating the completion of return goes on.

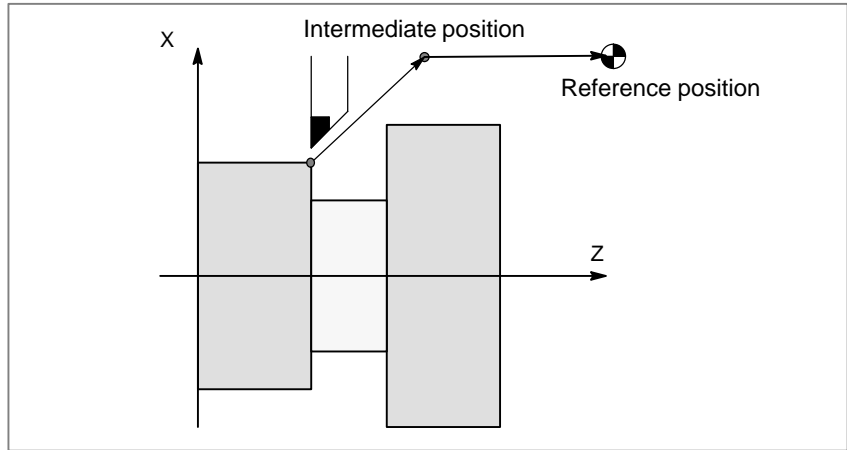

Fig. 6.2 (b) Reference position return

- **Reference position return check**

The reference position return check (G27) is the function which checks whether the tool has correctly returned to the reference position as specified in the program. If the tool has correctly returned to the reference position along a specified axis, the lamp for the axis goes on.

Format

- **Reference position return**

```

G28 IP _ ; Reference position return
G30 P2 IP _ ; 2nd reference position return (P2 can be omitted.)
G30 P3 IP _ ; 3rd reference position return
G30 P4 IP _ ; 4th reference position return

IP : Command specifying the intermediate position
(Absolute/incremental command)
    
```

- **Reference position return check**

```

G27 IP _ ;

IP : Command specifying the reference position
(Absolute/incremental command)
    
```

Explanations

- **Reference position return (G28)**
Positioning to the intermediate or reference positions are performed at the rapid traverse rate of each axis. Therefore, for safety, the tool nose radius compensation, and tool offset should be cancelled before executing this command.
- **2nd, 3rd, and 4th reference position return (G30)**
In a system without an absolute-position detector, the first, third, and fourth reference position return functions can be used only after the reference position return (G28) or manual reference position return (see III-3.1) is made. The G30 command is generally used when the automatic tool changer (ATC) position differs from the reference position.
- **Reference position return check (G27)**
G27 command positions the tool at rapid traverse rate. If the tool reaches the reference position, the reference position return lamp lights up. However, if the position reached by the tool is not the reference position, an alarm (No. 092) is displayed.

Restrictions

- **Status the machine lock being turned on**
The lamp for indicating the completion of return does not go on when the machine lock is turned on, even when the tool has automatically returned to the reference position. In this case, it is not checked whether the tool has returned to the reference position even when a G27 command is specified.
- **First return to the reference position after the power has been turned on (without an absolute position detector)**
When the G28 command is specified when manual return to the reference position has not been performed after the power has been turned on, the movement from the intermediate point is the same as in manual return to the reference position. In this case, the tool moves in the direction for reference position return specified in parameter ZMIx (bit 5 of No. 1006). Therefore the specified intermediate position must be a position to which reference position return is possible.
- **Reference position return check in an offset mode**
In an offset mode, the position to be reached by the tool with the G27 command is the position obtained by adding the offset value. Therefore, if the position with the offset value added is not the reference position, the lamp does not light up, but an alarm is displayed instead. Usually, cancel offsets before G27 is commanded.
- **Lighting the lamp when the programmed position does not coincide with the reference position**
When the machine tool is an inch system with metric input, the reference position return lamp may also light up even if the programmed position is shifted from the reference position by least input increment. This is because the least input increment of the machine is smaller than its least command increment.

Reference

- **Manual reference position return**
See III-3.1.

6.2 FLOATING REFERENCE POSITION RETURN (G30.1)

Tools can be returned to the floating reference position.

A floating reference point is a position on a machine tool, and serves as a reference point for machine tool operation.

A floating reference point need not always be fixed, but can be moved as required.

Format

G30.1 IP ;

IP _ : Command of the intermediate position of the floating reference position
(Absolute command/incremental command)

Explanations

On some machine tools, the cutting tools can be replaced at any position unless they interfere with the workpiece or tail stock.

With these machines, the cutting tools should be replaced at a position as close to the workpiece as possible so as to minimize the machine cycle time. For this purpose, the tool change position is to be changed, depending on the figure of the workpiece. This operation can easily be performed using this function. That is, a tool change position suitable for the workpiece is memorized as a floating reference point. Then command G30.1 can easily cause return to the tool change position.

- Floating reference position

The G30.1 block first positions the tool at the intermediate point along the specified axes at rapid traverse rate, then further moves the tool from the intermediate point to the floating reference point at rapid traverse rate. Before using G30.1, cancel cutter compensation and tool offset.

- Setting of floating reference position

A floating reference point becomes a machine coordinate position memorized by pressing the soft key **[SET FRP]** on the current positions display screen.

A floating reference point is not lost even if power is turned off.

Examples

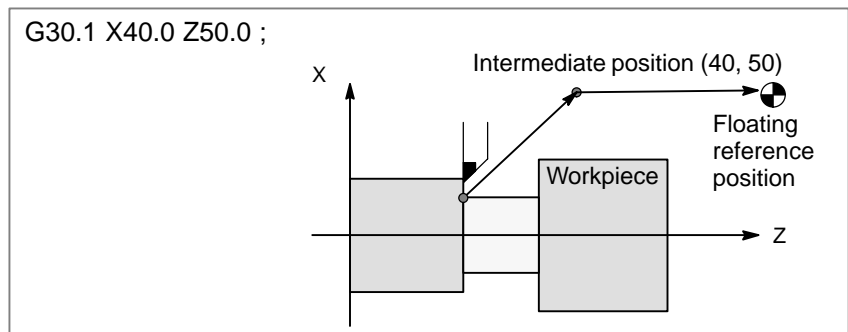

7 COORDINATE SYSTEM

By teaching the CNC a desired tool position, the tool can be moved to the position. Such a tool position is represented by coordinates in a coordinate system. Coordinates are specified using program axes. When two program axes, the X-axis and Z-axis, are used, coordinates are specified as follows:

X_Z_

This command is referred to as a dimension word.

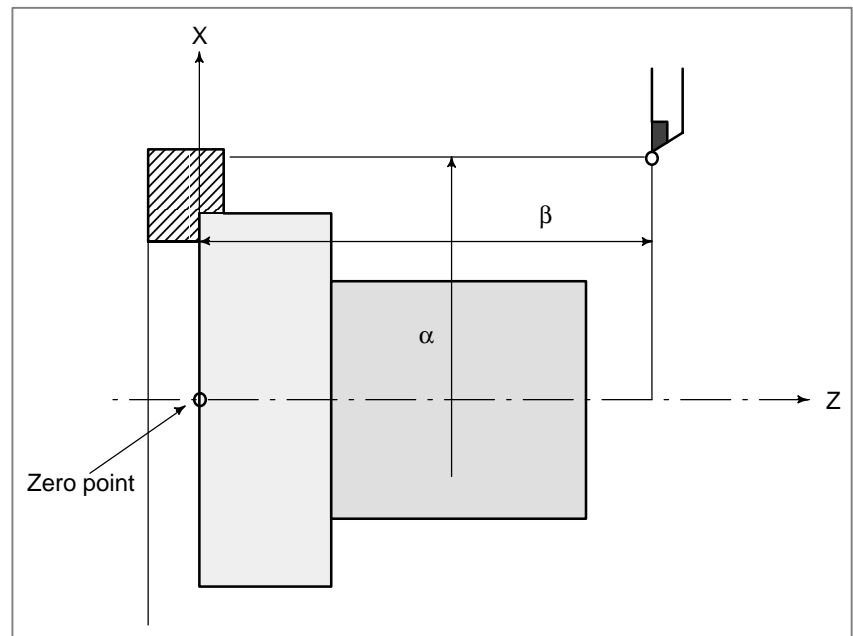

Fig. 7 Tool Position Specified by $X\alpha Z\beta$

Coordinates are specified in one of following three coordinate systems:

- (1) Machine coordinate system
- (2) Workpiece coordinate system
- (3) Local coordinate system

The number of the axes of a coordinate system varies from one machine to another. So, in this manual, a dimension word is represented as **IP_**.

7.1 MACHINE COORDINATE SYSTEM

The point that is specific to a machine and serves as the reference of the machine is referred to as the machine zero point. A machine tool builder sets a machine zero point for each machine.

A coordinate system with a machine zero point set as its origin is referred to as a machine coordinate system.

A machine coordinate system is set by performing manual reference position return after power-on (see III-3.1). A machine coordinate system, once set, remains unchanged until the power is turned off.

Format

```
G53 IP _ ;
      IP _; Absolute dimension word
```

Explanations

- **Selecting a machine coordinate system (G53)**

When a position has been specified as a set of machine coordinates, the tool moves to that position by means of rapid traverse. G53, used for selecting the machine coordinate system, is a one-shot G code. Any commands based on the selected machine coordinate system are thus effective only in the block containing G53. The G53 command must be specified using absolute values. If incremental values are specified, the G53 command is ignored. When the tool is to be moved to a machine-specific position such as a tool change position, program the movement in a machine coordinate system based on G53.

Restrictions

- **Cancel of the compensation function**
- **G53 specification immediately after power-on**

When the G53 command is specified, cancel the tool nose radius compensation and tool offset.

Since the machine coordinate system must be set before the G53 command is specified, at least one manual reference position return or automatic reference position return by the G28 command must be performed after the power is turned on. This is not necessary when an absolute-position detector is attached.

Reference

When manual reference position return is performed after power-on, a machine coordinate system is set so that the reference position is at the coordinate values of (α , β) set using parameter No.1240.

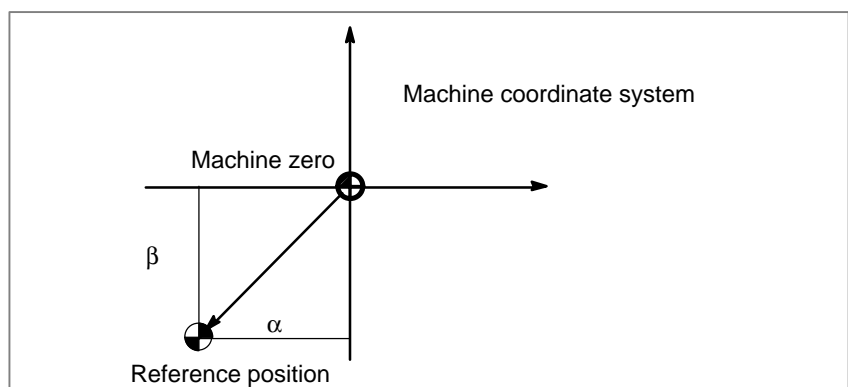

7.2 WORKPIECE COORDINATE SYSTEM

A coordinate system used for machining a workpiece is referred to as a workpiece coordinate system. A workpiece coordinate system is to be set with the NC beforehand (**setting a workpiece coordinate system**).

A machining program sets a workpiece coordinate system (**selecting a workpiece coordinate system**).

A set workpiece coordinate system can be changed by shifting its origin (**changing a workpiece coordinate system**).

7.2.1 Setting a Workpiece Coordinate System

A workpiece coordinate system can be set using one of three methods:

(1) Method using G50

A workpiece coordinate system is set by specifying a value after G50 in the program.

(2) Automatic setting

If bit 0 of parameter No. 1201 is set beforehand, a workpiece coordinate system is automatically set when manual reference position return is performed (see III-3.1.).

This function is, however, disabled when the workpiece coordinate system option is being used.

(3) Input using the MDI panel

Six workpiece coordinate systems can be set beforehand using the MDI panel.

Program commands G54 to G59 can be used to select the work axis to be used. (see III-11.4.10.)

When an absolute command is used, a workpiece coordinate system must be established in any of the ways described above.

Format

- Setting a workpiece coordinate system by G50

G50 IP_

Explanations

A workpiece coordinate system is set so that a point on the tool, such as the tool tip, is at specified coordinates. If IP is an incremental command value, the work coordinate system is defined so that the current tool position coincides with the result of adding the specified incremental value to the coordinates of the previous tool position. If a coordinate system is set using G50 during offset, a coordinate system in which the position before offset matches the position specified in G50 is set.

Examples

Example 1

Setting the coordinate system by the
G50X128.7Z375.1; command (Diameter designation)

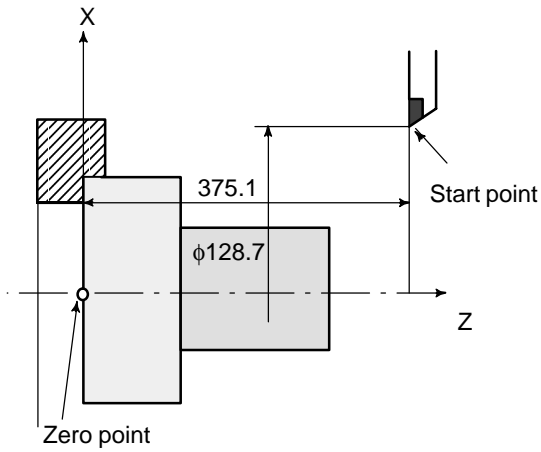

Example 2

Base point

Setting the coordinate system by the
G50X1200.0Z700.0; command (Diameter designation)

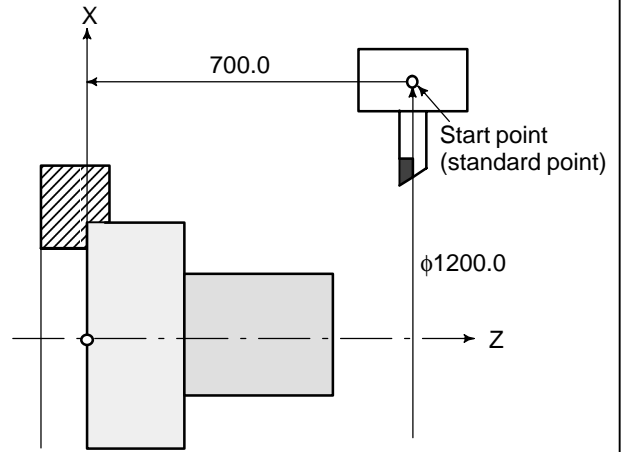

7.2.2 Selecting a Workpiece Coordinate System

The user can choose from set workpiece coordinate systems as described below. (For information about the methods of setting, see Subsec. II-7.2.1.)

(1) G50 or automatic workpiece coordinate system setting

Once a workpiece coordinate system is selected, absolute commands work with the workpiece coordinate system.

(2) Choosing from six workpiece coordinate systems set using the MDI

By specifying a G code from G54 to G59, one of the workpiece coordinate systems 1 to 6 can be selected.

G54 Workpiece coordinate system 1

G55 Workpiece coordinate system 2

G56 Workpiece coordinate system 3

G57 Workpiece coordinate system 4

G58 Workpiece coordinate system 5

G59 Workpiece coordinate system 6

Workpiece coordinate system 1 to 6 are established after reference position return after the power is turned on. When the power is turned on, G54 coordinate system is selected.

When bit 2 (G50) of parameter No. 1202 is set to 1, executing the G50 command results in the issue of P/S alarm No. 10. This is designed to prevent the user from confusing coordinate systems.

Examples

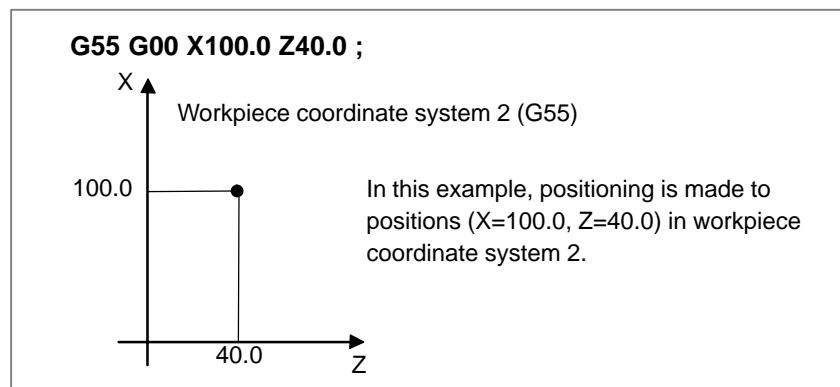

Fig. 7.2.2

7.2.3 Changing Workpiece Coordinate System

The six workpiece coordinate systems specified with G54 to G59 can be changed by changing an external workpiece zero point offset value or workpiece zero point offset value.

Three methods are available to change an external workpiece zero point offset value or workpiece zero point offset value.

- (1) Inputting from the MDI panel (see III-11.4.10)
- (2) Programming by G10 or G50
- (3) Using the external data input function

An external workpiece origin offset can be changed by using a signal input to the CNC. For details, refer to the relevant manual supplied by the machine tool builder.

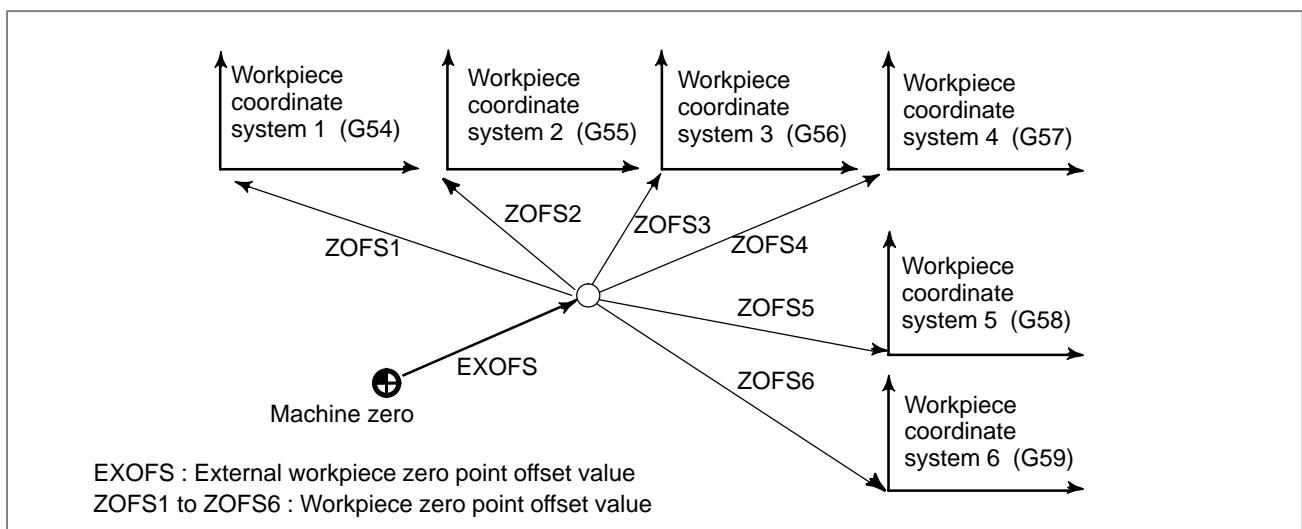

Fig. 7.2.3 Changing an external workpiece zero point offset value or workpiece zero point offset value

Format

- Changing by G10

G10 L2 Pp IP _;

p=0 : External workpiece zero point offset value

p=1 to 6 : Workpiece zero point offset value correspond to workpiece coordinate system 1 to 6

IP : For an absolute command (G90), workpiece zero point offset for each axis.

For an incremental command (G91), value to be added to the set workpiece zero point offset for each axis (the sum is set as the new offset).

- Changing by G50

G50 IP _;

Explanations

- **Changing by G10**
- **Changing by G50**

With the G10 command, each workpiece coordinate system can be changed separately.

By specifying G50IP_;, a workpiece coordinate system (selected with a code from G54 to G59) is shifted to set a new workpiece coordinate system so that the current tool position matches the specified coordinates (IP_).

If IP is an incremental command value, the work coordinate system is defined so that the current tool position coincides with the result of adding the specified incremental value to the coordinates of the previous tool position. (Coordinate system shift)

Then, the amount of coordinate system shift is added to all the workpiece zero point offset values. This means that all the workpiece coordinate systems are shifted by the same amount.

Examples

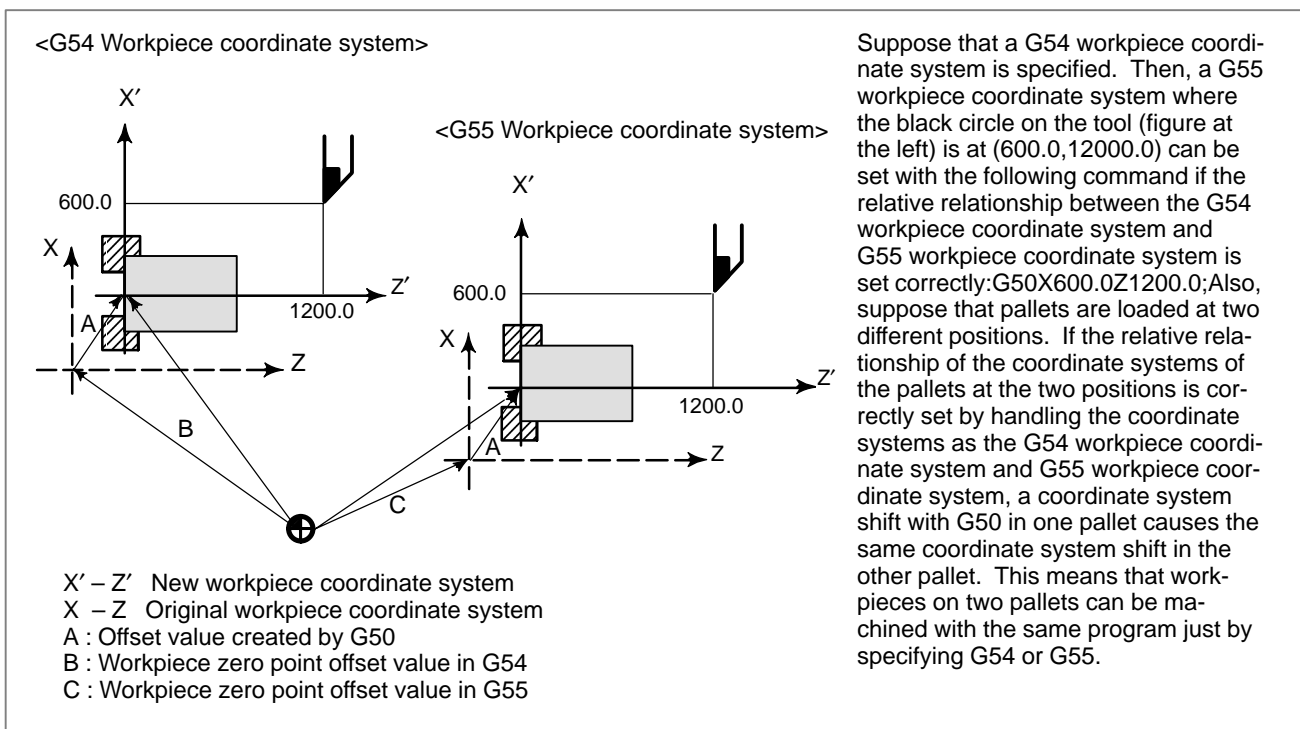
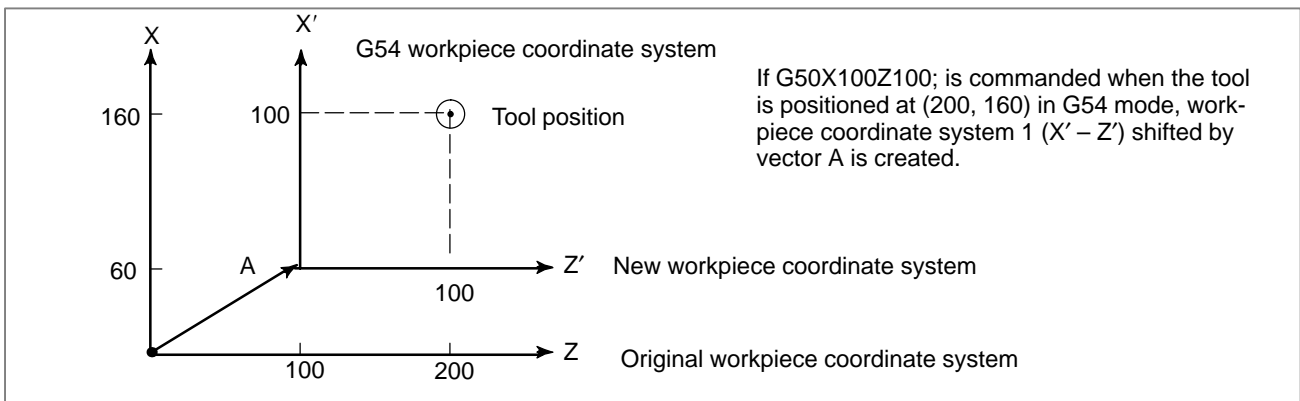

7.2.4 Workpiece Coordinate System Preset (G92.1)

The workpiece coordinate system preset function presets a workpiece coordinate system shifted by manual intervention to the pre-shift workpiece coordinate system. The latter system is displaced from the machine zero point by a workpiece zero point offset value.

There are two methods for using the workpiece coordinate system preset function. One method uses a programmed command (G92.1). The other uses MDI operations on the absolute position display screen, relative position display screen, and overall position display screen (III – 11.1.4).

Format

G92.1 IP 0 ; (G50.3 P0 ; for G code system A)
IP 0 ; Specifies axis addresses subject to the workpiece coordinate system preset operation. Axes that are not specified are not subject to the preset operation.

Explanations

When manual reference position return operation is performed in the reset state, a workpiece coordinate system is shifted by the workpiece zero point offset value from the machine coordinate system zero point. Suppose that the manual reference position return operation is performed when a workpiece coordinate system is selected with G54. In this case, a workpiece coordinate system is automatically set which has its zero point displaced from the machine zero point by the G54 workpiece zero point offset value; the distance from the zero point of the workpiece coordinate system to the reference position represents the current position in the workpiece coordinate system.

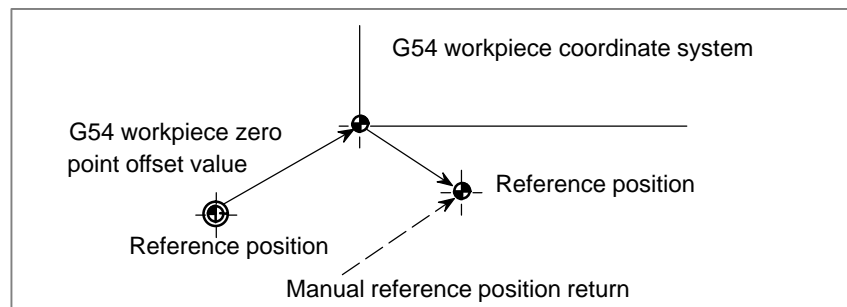

If an absolute position detector is provided, the workpiece coordinate system automatically set at power-up has its zero point displaced from the machine zero point by the G54 workpiece zero point offset value. The machine position at the time of power-up is read from the absolute position detector and the current position in the workpiece coordinate system is set by subtracting the G54 workpiece zero point offset value from this machine position. The workpiece coordinate system set by these operations is shifted from the machine coordinate system using the commands and operations listed next page.

- (a) Manual intervention performed when the manual absolute signal is off
- (b) Move command executed in the machine lock state
- (c) Movement by handle interrupt
- (d) Operation using the mirror image function
- (e) Setting the local coordinate system using G52, or shifting the workpiece coordinate system using G92

In the case of (a) above, the workpiece coordinate system is shifted by the amount of movement during manual intervention.

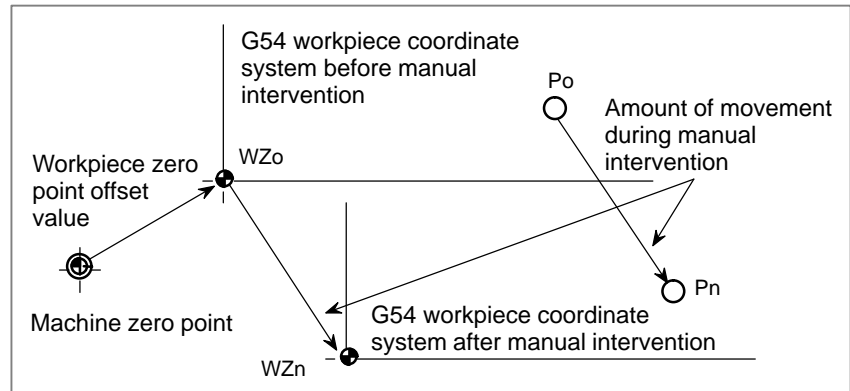

In the operation above, a workpiece coordinate system once shifted can be preset using G code specification or MDI operation to a workpiece coordinate system displaced by a workpiece zero point offset value from the machine zero point. This is the same as when manual reference position return operation is performed on a workpiece coordinate system that has been shifted. In this example, such G code specification or MDI operation has the effect of returning workpiece coordinate system zero point WZn to the original zero point WZo, and the distance from WZo to Pn is used to represent the current position in the workpiece coordinate system.

Bit 3 (PPD) of parameter No. 3104 specifies whether to preset relative coordinates (RELATIVE) as well as absolute coordinates.

When no workpiece coordinate system option (G54 to G59) is selected, the workpiece coordinate system is preset to the coordinate system set by automatic workpiece coordinate system setting. When automatic workpiece coordinate system setting is not selected, the workpiece coordinate system is preset with its zero point placed at the reference position.

Restrictions

- **Cutter compensation, tool length compensation, tool offset**
- **Program restart**
- **Prohibited modes**

When using the workpiece coordinate system preset function, cancel compensation modes: cutter compensation, tool length compensation, and tool offset. If the function is executed without cancelling these modes, compensation vectors are temporarily cancelled.

The workpiece coordinate system preset function is not executed during program restart.

Do not use the workpiece coordinate system preset function when the scaling, coordinate system rotation, programmable image, or drawing copy mode is set.

7.2.5 Workpiece Coordinate System Shift

When the coordinate system actually set by the G50 command or the automatic system setting deviates from the programmed work system, the set coordinate system can be shifted (see III-3.1).

Set the desired shift amount in the work coordinate system shift memory.

Explanations

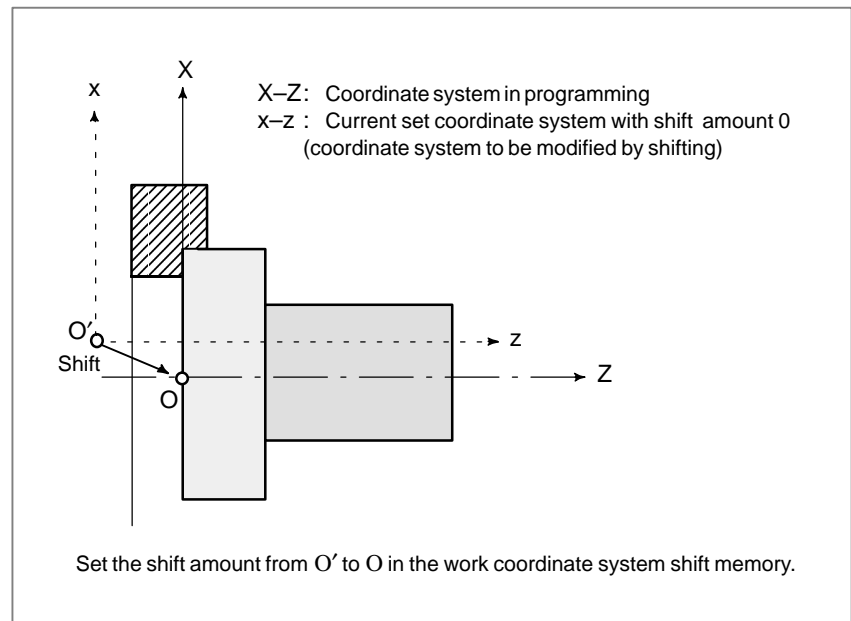

Fig. 7.2.5 Workpiece Coordinate System shift

See Section III-11.4.5 of Part III for how to specify the distance the work coordinate system is shifted.

7.3 LOCAL COORDINATE SYSTEM

When a program is created in a workpiece coordinate system, a child workpiece coordinate system may be set for easier programming. Such a child coordinate system is referred to as a local coordinate system.

Format

G52 IP _; Setting the local coordinate system

.....

G52 IP 0 ; Canceling of the local coordinate system

IP _ : Origin of the local coordinate system

Explanations

By specifying G52IP_;, a local coordinate system can be set in all the workpiece coordinate systems (G54 to G59). The origin of each local coordinate system is set at the position specified by IP_ in the workpiece coordinate system.

Once a local coordinate system is established, the coordinates in the local coordinate system are used in an axis shift command. The local coordinate system can be changed by specifying the G52 command with the zero point of a new local coordinate system in the workpiece coordinate system.

To cancel the local coordinate system and specify the coordinate value in the workpiece coordinate system, match the zero point of the local coordinate system with that of the workpiece coordinate system.

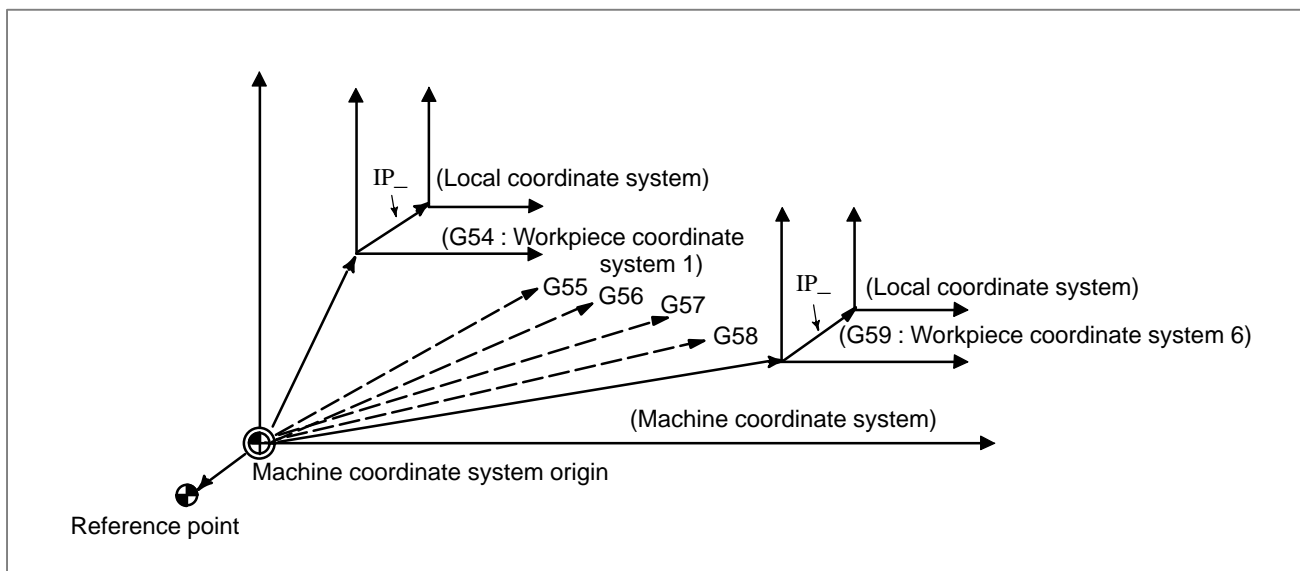

Fig. 7.3 Setting the local coordinate system

WARNING

- 1 The local coordinate system setting does not change the workpiece and machine coordinate systems.
- 2 When G50 is used to define a work coordinate system, if coordinates are not specified for all axes of a local coordinate system, the local coordinate system remains unchanged.
If coordinates are specified for any axis of a local coordinate system, the local coordinate system is canceled.
- 3 G52 cancels the offset temporarily in tool nose radius compensation.
- 4 Command a move command immediately after the G52 block in the absolute mode.
- 5 Whether the local coordinate system is canceled upon reset depends on the specified parameters. The local coordinate system is canceled upon reset when bit 6 (CLR) of parameter No. 3402 or bit 3 (RLC) of parameter No. 1202 is set to 1.

7.4 PLANE SELECTION

Select the planes for circular interpolation, tool nose radius compensation, coordinate system rotation, and drilling by G-code. The following table lists G-codes and the planes selected by them.

Explanations

Table 7.4 Plane selected by G code

G code	Selected plane	Xp	Yp	Zp
G17	Xp Yp plane	X-axis or an axis parallel to it	Y-axis or an axis parallel to it	Z-axis or an axis parallel to it
G18	Zp Xp plane			
G19	Yp Zp plane			

Xp, Yp, Zp are determined by the axis address appeared in the block in which G17, G18 or G19 is commanded.

When an axis address is omitted in G17, G18 or G19 block, it is assumed that the addresses of basic three axes are omitted.

Parameter No. 1022 specifies whether each axis is a basic axis (X-axis, Y-axis, or Z-axis) or an axis parallel to a basic axis.

The plane is unchanged in the block in which G17, G18 or G19 is not commanded.

When the power is turned on, G18 (ZX plane) is selected .

The movement instruction is irrelevant to the plane selection.

NOTE

- 1 U-, V-, and W-axes (parallel to a basic axis) can be used with G-codes B and C.
- 2 Direct drawing dimension programming, chamfering, corner R, multiple repetitive canned cycle, and simple canned cycle are enabled only for the ZX plane.
Specifying these functions for other planes causes P/S alarm No. 212 to be generated.

Examples

Plane selection when the X-axis is parallel with the U-axis.

G17X_Y_; XY plane,

G17U_Y_; UY plane

G18X_Z_; ZX plane

X_Y_; Plane is unchanged (ZX plane)

G17; XY plane

G18; ZX plane

G17 U_; UY plane

G18Y_; ZX plane, Y axis moves regardless without any relation to the plane.

8

COORDINATE VALUE AND DIMENSION



This chapter contains the following topics.

8.1 ABSOLUTE AND INCREMENTAL PROGRAMMING (G90, G91)

8.2 INCH/METRIC CONVERSION (G20, G21)

8.3 DECIMAL POINT PROGRAMMING

8.4 DIAMETER AND RADIUS PROGRAMMING

8.1 ABSOLUTE AND INCREMENTAL PROGRAMMING (G90, G91)

There are two ways to command travels of the tool; the absolute command, and the incremental command. In the absolute command, coordinate value of the end position is programmed; in the incremental command, move distance of the position itself is programmed. G90 and G91 are used to command absolute or incremental command, respectively.

Absolute programming or incremental programming is used depending on the command used. See following tables.

G code system	A	B or C
Command method	Address word	G90, G91

Format

- G code system A

	Absolute command	Incremental command
X axis move command	X	U
Z axis move command	Z	W
Y axis move command	Y	V
C axis move command	C	H

- G code system B or C

Absolute command	G90 IP_n ;
Incremental command	G91 IP_n ;

Examples

- Tool movement from point P to point Q (diameter programming is used for the X-axis)

	G code system A	G code system B or C
Absolute command	X400.0 Z50.0 ;	G90 X400.0 Z50.0 ;
Incremental command	U200.0 W-400.0 ;	G91 X200.0 Z-400.0 ;

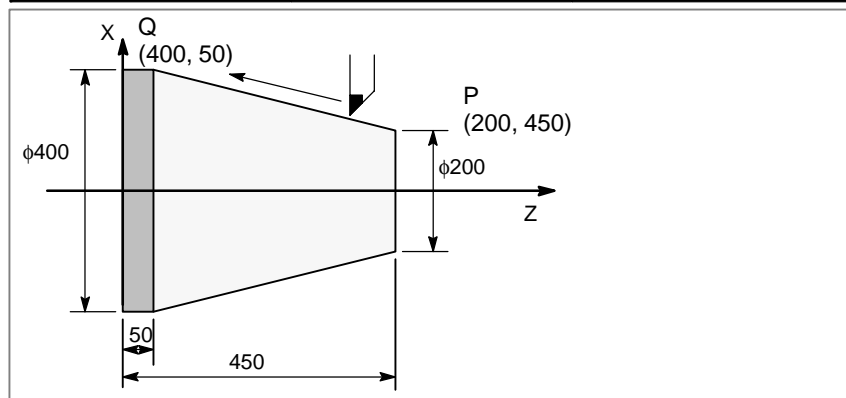

NOTE

- Absolute and incremental commands can be used together in a block.
In the above example, the following command can be specified :
X400.0 W-400.0 ;
- When both X and U or W and Z are used together in a block, the one specified later is effective.
- Incremental commands cannot be used when names of the axes are A and B during G code system A is selected.

8.2 INCH/METRIC CONVERSION (G20, G21) Format

Either inch or metric input can be selected by G code.

G20 ; Inch input
G21 ; mm input

This G code must be specified in an independent block before setting the coordinate system at the beginning of the program. After the G code for inch/metric conversion is specified, the unit of input data is switched to the least inch or metric input increment of increment system IS-B or IS-C (Section II-2.3). The unit of data input for degrees remains unchanged. The unit systems for the following values are changed after inch/metric conversion:

- Feedrate commanded by F code
- Positional command
- Work zero point offset value
- Tool compensation value
- Unit of scale for manual pulse generator
- Movement distance in incremental feed
- Some parameters

When the power is turned on, the G code is the same as that held before the power was turned off.

WARNING

- 1 G20 and G21 must not be switched during a program.
- 2 When switching inch input (G20) to metric input (G21) and vice versa, the tool compensation value must be re-set according to the least input increment. However, when bit 0 (OIM) of parameter 5006 is 1, tool compensation values are automatically converted and need not be re-set.

CAUTION

Movement from the intermediate point is the same as that for manual reference position return. The direction in which the tool moves from the intermediate point is the same as the reference position return direction, as specified with bit 5 (ZMI) of parameter No. 1006.

NOTE

- 1 When the least input increment and the least command increment systems are different, the maximum error is half of the least command increment. This error is not accumulated.
- 2 The inch and metric input can also be switched using setting of data setting (III-11.4.7).

8.3 DECIMAL POINT PROGRAMMING

Numerical values can be entered with a decimal point. A decimal point can be used when entering a distance, time, or speed. Decimal points can be specified with the following addresses:

X, Y, Z, U, V, W, A, B, C, I, J, K, R, and F.

Explanations

There are two types of decimal point notation: calculator-type notation and standard notation.

When calculator-type decimal notation is used, a value without decimal point is considered to be specified in millimeters. When standard decimal notation is used, such a value is considered to be specified in least input increments. Select either calculator-type or standard decimal notation by using the DPI bit (bit 0 of parameter 3401). Values can be specified both with and without decimal point in a single program.

Examples

Program command	Pocket calculator type decimal point programming	Standard type decimal point programming
X1000 Command value without decimal point	1000mm Unit : mm	1mm Unit : Least input increment (0.001 mm)
X1000.0 Command value with decimal point	1000mm Unit : mm	1000mm Unit : mm

WARNING

In a single block, specify a G code before entering a value. The position of decimal point may depend on the command.

Examples:

G20; Input in inches

X1.0 G04; X1.0 is considered to be a distance and processed as X10000. This command is equivalent to G04 X10000. The tool dwells for 10 seconds.

G04 X1.0; Equivalent to G04 X1000. The tool dwells for one second.

NOTE

- 1 Fractions less than the least input increment are truncated.

Examples:

X1.23456; Truncated to X1.234 when the least input increment is 0.001 mm.
Processed as X1.2345 when the least input increment is 0.0001 inch.

- 2 When more than eight digits are specified, an alarm occurs. If a value is entered with a decimal point, the number of digits is also checked after the value is converted to an integer according to the least input increment.

Examples:

X1.23456789; P/S alarm 003 occurs because more than eight digits are specified.

X123456.7; If the least input increment is 0.001 mm, the value is converted to integer 123456700. Because the integer has more than eight digits, an P/S alarm 003 occurs.

8.4 DIAMETER AND RADIUS PROGRAMMING

Since the work cross section is usually circular in CNC lathe control programming, its dimensions can be specified in two ways :

Diameter and Radius

When the diameter is specified, it is called diameter programming and when the radius is specified, it is called radius programming.

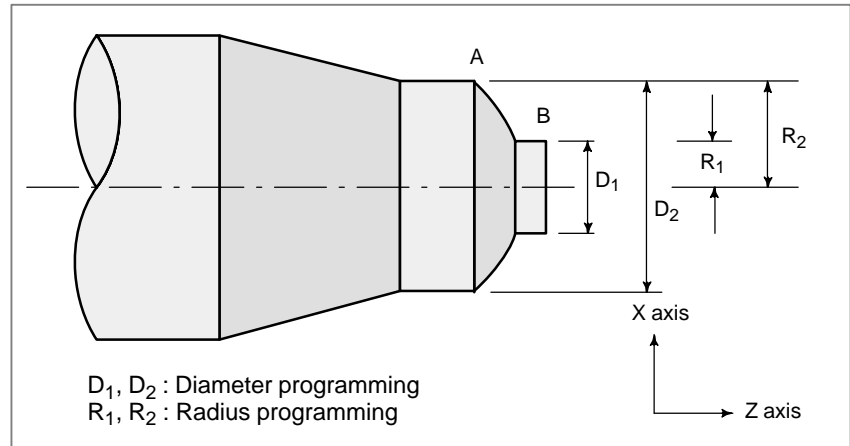

Explanations

- Notes on diameter programming/radius programming for each command

Radius programming or diameter programming can be specified by parameter DIA (No.1006#3). When using diameter programming, note the conditions listed in the table 8.4.

Table 8.4 Notes on specifying diameter value

Item	Notes
X axis command	Specified with a diameter value
Incremental command	Specified with a diameter value In the above figure, specifies D2 minus D1 for tool path B to A.
Coordinate system setting (G50)	Specifies a coordinate value with a diameter value
Component of tool offset value	Parameter (No.5004#1) determines either diameter or radius value
Parameters in canned cycle, such as cutting depth along X axis. (R)	Specifies a radius value
Radius designation in circular interpolation (R, I, K, and etc.)	Specifies a radius value
Feedrate along axis	Specifies change of radius/rev. or change of radius/min.
Display of axis position	Displayed as diameter value

9

SPINDLE SPEED FUNCTION



The spindle speed can be controlled by specifying a value following address S.

In addition, the spindle can be rotated by a specified angle.

This chapter contains the following topics.

9.1 SPECIFYING THE SPINDLE SPEED WITH A CODE

9.2 SPECIFYING THE SPINDLE SPEED VALUE DIRECTLY (S5-DIGIT COMMAND)

9.3 CONSTANT SURFACE SPEED CONTROL (G96, G97)

9.4 SPINDLE SPEED FLUCTUATION DETECTION FUNCTION (G25, G26)

9.5 SPINDLE POSITIONING FUNCTION

9.1 SPECIFYING THE SPINDLE SPEED WITH A CODE

Specifying a value following address S sends code and strobe signals to the machine. On the machine, the signals are used to control the spindle speed. A block can contain only one S code. Refer to the appropriate manual provided by the machine tool builder for details such as the number of digits in an S code or the execution order when a move command and an S code command are in the same block.

9.2 SPECIFYING THE SPINDLE SPEED VALUE DIRECTLY (S5-DIGIT COMMAND)

The spindle speed can be specified directly by address S followed by a five-digit value (min^{-1}). The unit for specifying the spindle speed may vary depending on the machine tool builder. Refer to the appropriate manual provided by the machine tool builder for details.

9.3 CONSTANT SURFACE SPEED CONTROL (G96, G97)

Specify the surface speed (relative speed between the tool and workpiece) following S. The spindle is rotated so that the surface speed is constant regardless of the position of the tool.

Format

- Constant surface speed control command

G96 S○○○○○ ;

↑Surface speed (m/min or feet/min)

Note : This surface speed unit may change according to machine tool builder's specification.

- Constant surface speed control cancel command

G97 S○○○○○ ;

↑Spindle speed (min^{-1})

Note : This surface speed unit may change according to machine tool builder's specification.

- Clamp of maximum spindle speed

G50 S ; The maximum spindle speed (min^{-1}) follows S.

Explanations

- **Constant surface speed control command (G96)**

G96 (constant surface speed control command) is a modal G code. After a G96 command is specified, the program enters the constant surface speed control mode (G96 mode) and specified S values are assumed as a surface speed. A G96 command must specify the axis along which constant surface speed control is applied. A G97 command cancels the G96 mode. When constant surface speed control is applied, a spindle speed higher than the value specified in G50S_; (maximum spindle speed) is clamped at the maximum spindle speed. When the power is turned on, the maximum spindle speed is not yet set and the speed is not clamped. S (surface speed) commands in the G96 mode are assumed as $S = 0$ (the surface speed is 0) until M03 (rotating the spindle in the positive direction) or M04 (rotating the spindle in the negative direction) appears in the program.

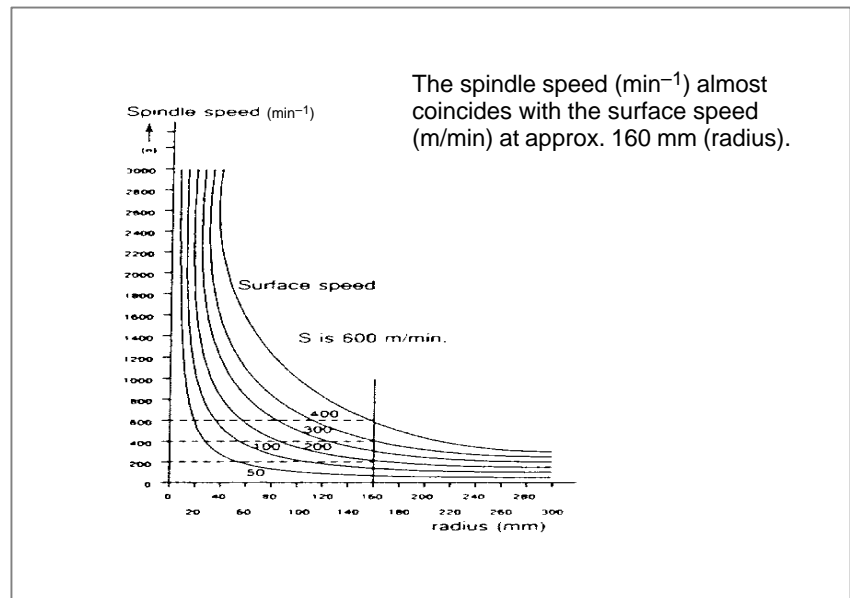

Fig. 9.3 (a) Relation between workpiece radius, spindle speed and surface speed

- **Setting the workpiece coordinate system for constant surface speed control**

To execute the constant surface speed control, it is necessary to set the work coordinate system, Z axis, (axis to which the constant surface speed control applies) becomes zero.

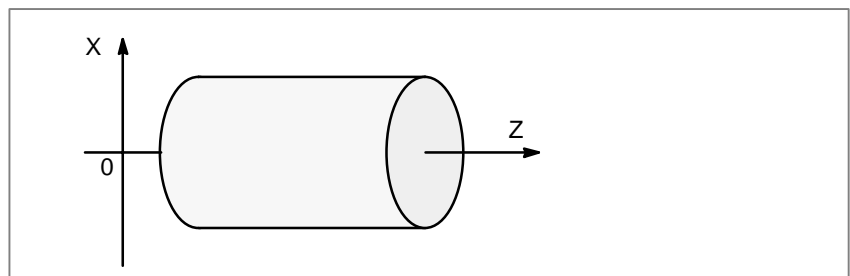
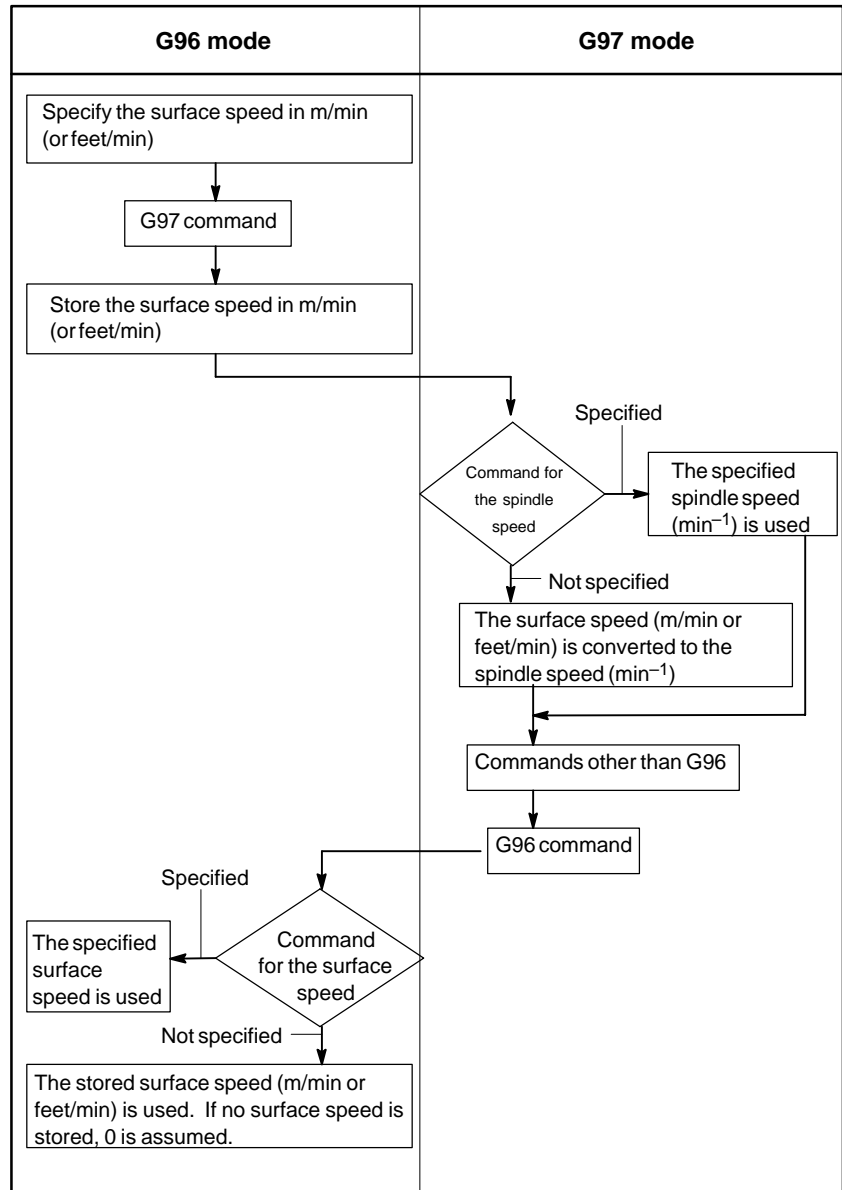

Fig. 9.3 (b) Example of the Workpiece Coordinate System for Constant Surface Speed Control

● **Surface speed specified in the G96 mode**



Restrictions

● **Constant surface speed control for threading**

The constant surface speed control is also effective during threading. Accordingly, it is recommended that the constant surface speed control be invalidated with G97 command before starting the scroll threading and taper threading, because the response problem in the servo system may not be considered when the spindle speed changes.

- **Constant surface speed control for rapid traverse (G00)**

In a rapid traverse block specified by G00, the constant surface speed control is not made by calculating the surface speed to a transient change of the tool position, but is made by calculating the surface speed based on the position at the end point of the rapid traverse block, on the condition that cutting is not executed at rapid traverse.

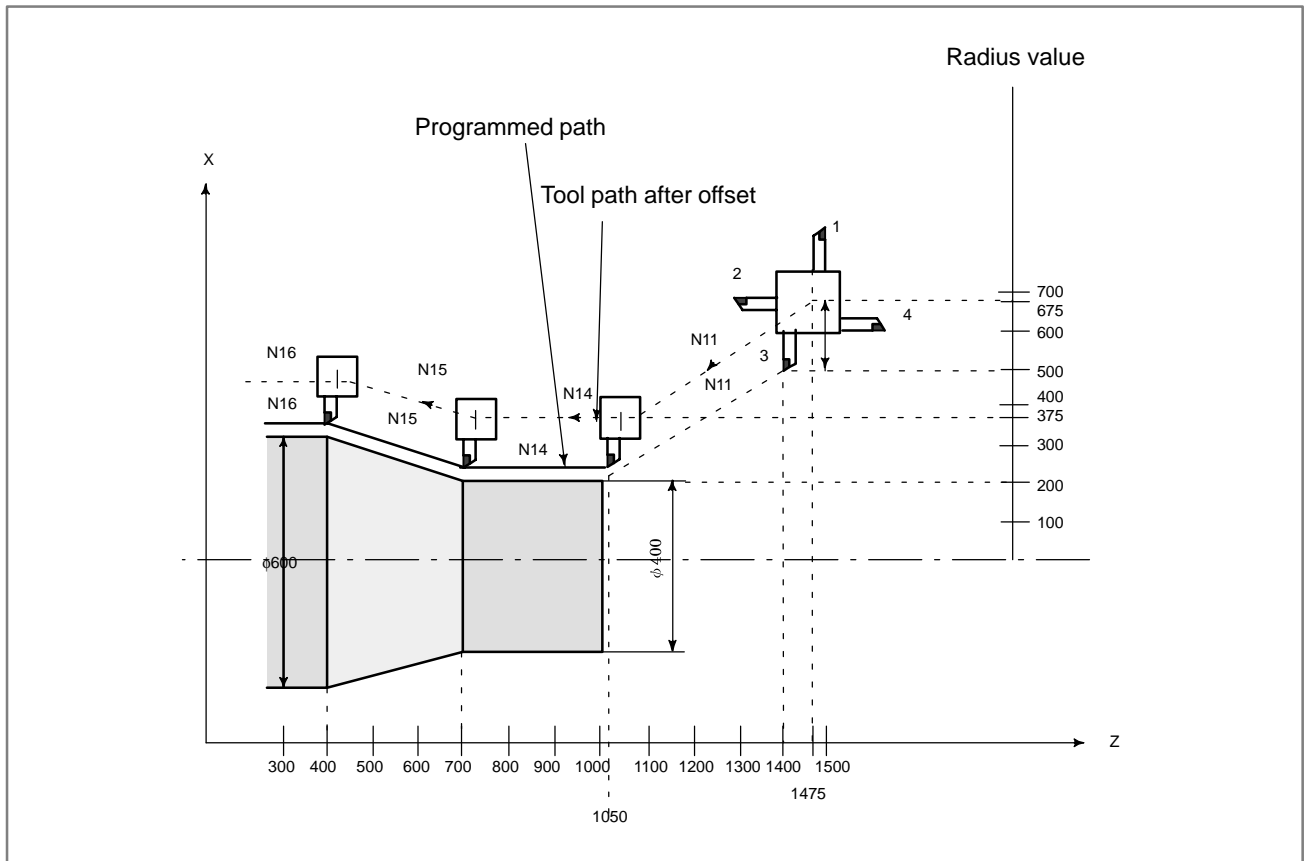

Example

```

N8 G00 X1000.0Z1400.0 ;
N9 T33;
N11 X400.0Z1050.0;
N12 G50S3000 ; (Designation of max. spindle speed)
N13 G96S200 ; (Surface speed 200 m/min)
N14 G01 Z 700.0F1000 ;
N15 X600.0Z 400.0;
N16 Z ... ;

```

The CNC calculates the spindle speed which is proportional to the specified surface speed at the position of the programmed coordinate value on the X axis. This is not the value calculated according to the X axis coordinate after offset when offset is valid. At the end point N15 in the example above, the speed at 600 dia. (Which is not the turret center but the tool nose) is 200 m/min. If X axis coordinate value is negative, the CNC uses the absolute value.

9.4 SPINDLE SPEED FLUCTUATION DETECTION FUNCTION (G25, G26)

With this function, an overheat alarm (No. 704) is raised when the spindle speed deviates from the specified speed due to machine conditions. This function is useful, for example, for preventing the seizure of the guide bushing.

Format

G26 enables spindle speed fluctuation detection.
G25 disables spindle speed fluctuation detection.

G26 Pp Qq Rr ;	Spindle fluctuation detection on
G25 ;	Spindle fluctuation detection off

p : Time (in ms) from the issue of a new spindle rotation command (S command) to the start of checking whether the actual spindle speed is so fast that an overheat can occur.

When a specified speed is reached within the time period of P, spindle speed is checked at that time.

q : Tolerance (%) of a specified spindle speed

$$q = \frac{1 - \text{actual spindle speed}}{\text{specified spindle speed}} \times 100$$

If a specified spindle speed lies within this range, it is regarded as having reached the specified value. Then, an actual spindle speed is checked.

r : Spindle speed fluctuation (%) at which the actual spindle speed is so fast that an overheat can occur

$$r = \frac{1 - \text{speed that can cause overheat}}{\text{specified spindle speed}} \times 100$$

G26 enables the spindle speed fluctuation detection function, and G25 disables the spindle speed fluctuation detection. Even if G25 is specified, p, q, and r are not cleared.

Explanations

The fluctuation of the spindle speed is detected as follows:

1. When an alarm is issued after a specified spindle speed is reached

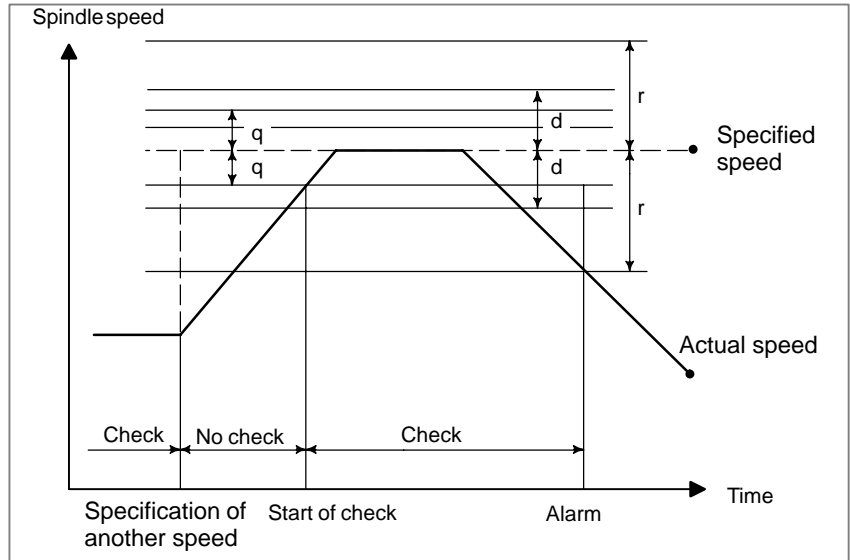

2. When an alarm is issued before a specified spindle speed is reached

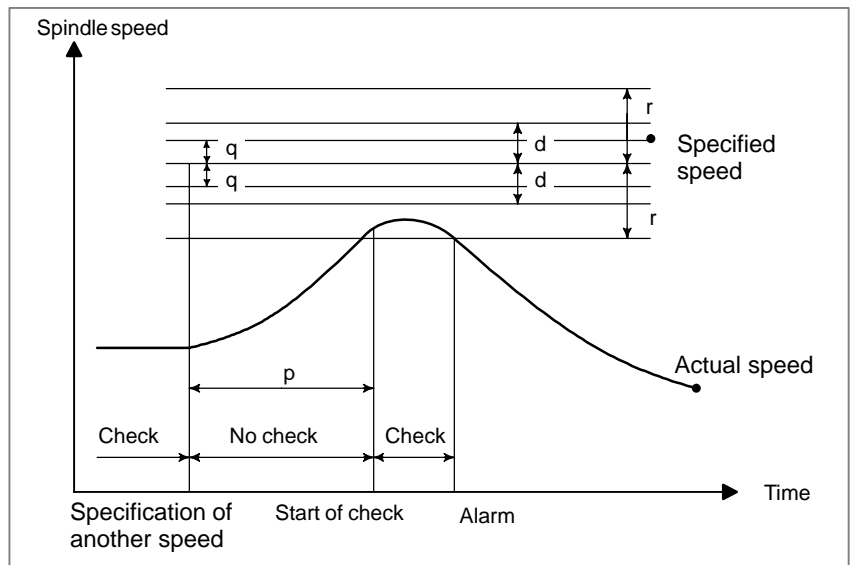

Specified speed :

(Speed specified by address S and five-digit value) × (spindle override)

Actual speed : Speed detected with a position coder

p : Time elapses since the specified speed changes until a check starts.

q : (Percentage tolerance for a check to start) × (specified speed)

r : (Percentage fluctuation detected as an alarm condition) × (specified speed)

d : Fluctuation detected as an alarm (specified in parameter 4913)

An alarm is issued when the difference between the specified speed and the actual speed exceeds both r and d.

NOTE

- 1 When an alarm is issued in automatic operation, a single block stop occurs. The spindle overheat alarm is indicated on the CRT screen, and the alarm signal "SPAL" is output (set to 1 for the presence of an alarm). This signal is cleared by resetting.
- 2 Even when reset operation is performed after an alarm occurs, the alarm is issued again unless the cause of the alarm is corrected.
- 3 No check is made during spindle stop state (*SSTP = 0).
- 4 By setting the parameter (No. 4913), an allowable range of speed fluctuations can be set which suppresses the occurrence of an alarm. However, an alarm is issued one second later if the actual speed is found to be 0 min⁻¹.

9.5 SPINDLE POSITIONING FUNCTION

In turning, the spindle connected to the spindle motor is rotated at a certain speed to rotate the workpiece mounted on the spindle. The spindle positioning function turns the spindle connected to the spindle motor by a certain angle to position the workpiece mounted on the spindle at a certain angle. The spindle is positioned about the C-axis.

The spindle positioning function involves the following three operations:

1. Canceling the spindle rotation mode and entering the spindle positioning mode (spindle orientation)
2. Positioning the spindle in the spindle positioning mode
3. Canceling the spindle positioning mode, and entering the spindle rotation mode

9.5.1 Spindle Orientation

When spindle positioning is first performed after the spindle motor is used for normal spindle operation, or when spindle positioning is interrupted, the spindle orientation is required.

Orientation permits the spindle to stop at a predetermined position.

Orientation is directed by the M code set in parameter No. 4960. The direction of orientation can be set with a parameter. For the analog spindle, the direction is set in ZMIx (bit 5 of parameter 1006).

For the serial spindle, it is set in RETRN (bit 5 of parameter 4005).

9.5.2 Spindle Positioning

The spindle can be positioned with an arbitrary angle or semi-fixed angle.

- **Positioning with a semi-fixed angle specified by an M code**

Address M is followed by a 2-digit numeric. The specifiable value may be one of the six values from $M\alpha$ to $M(\alpha+5)$. Value α must be set in parameter No. 4962 beforehand. The positioning angles corresponding to $M\alpha$ to $M(\alpha+5)$ are listed below. Value β must be set in parameter No. 4963 beforehand.

M-code	Positioning angle	(Ex.) $\beta=30^\circ$
$M\alpha$	β	30°
$M(\alpha+1)$	2β	60°
$M(\alpha+2)$	3β	90°
$M(\alpha+3)$	4β	120°
$M(\alpha+4)$	5β	150°
$M(\alpha+5)$	6β	180°

Specify the command with incremental values. The direction of rotation can be specified in parameter IDM (bit 1 of parameter 4950).

● **Positioning with a given angle specified by address C or H**

Specify the position using address C or H followed by a signed numeric value or numeric values. Addresses C and H must be specified in the G00 mode.

(Example) C-1000
H4500

The end point must be specified with a distance from the program reference position (in absolute mode) using address C. Alternatively, the end point must also be specified with a distance from the start point to the end point (in incremental mode) using address H.

A numeric with the decimal point can be entered.

The value must be specified in degrees.

(Example) C35.0=C35 degrees

● **Program reference position**

The position to which the spindle is oriented is assumed as the program reference position. The program reference position can be changed by setting of a coordinate system (G50) or automatic setting of a coordinate system (#OZPR of parameter 1202).

● **Feedrate for positioning**

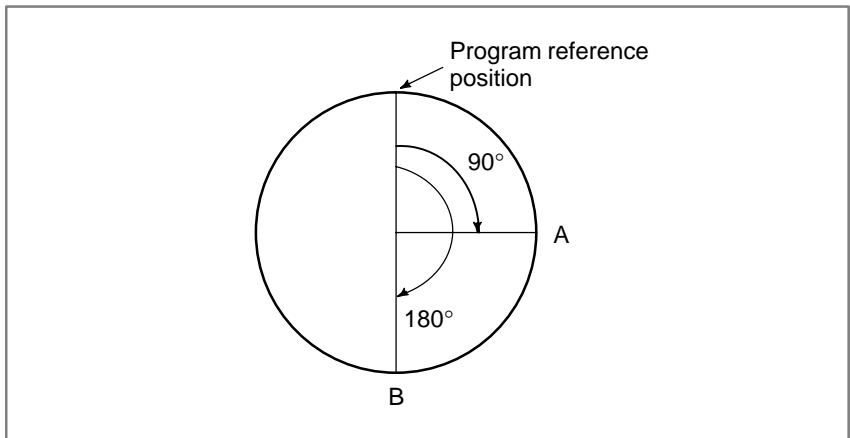

Command format		G code A		G code B and C	
		Addresses used	Command A-B in the above figure	Addresses used and G code	Command A-B in the above figure
Absolute command	Specify the end point with a distance from the program reference position.	C	C180.0 ;	G90,C	G90C180.;
Incremental command	Specify a distance from the start point to the end point.	H	H90.0 ;	G91,C	G90C90. ;

- **Feedrate during positioning**

The feedrate during positioning equals the rapid traverse speed specified in parameter No. 1420. Linear acceleration/deceleration is performed. For the specified speed, an override of 100%, 50%, 25%, and F0 (parameter No. 1421) can be applied.
- **Speed during orientation**

The tool moves at the rapid traverse speed set in parameter No.1420 until a sufficient speed for orientation is attained. After the speed for orientation has been attained, orientation is performed at the speed set in parameter No. 1425.

9.5.3 Canceling Spindle Positioning

When modes are to be switched from spindle positioning to normal spindle rotation, the M code set in parameter No. 4961 is specified.

WARNING

- 1 Feed hold, dry run, machine lock, and auxiliary function lock cannot be performed during spindle positioning.
- 2 Parameter No. 4962 must always be set even when positioning with a semi-fixed angle specified in an M-code is not performed. If the parameter is not set, M-codes from the M00 to M05 do not function properly.

NOTE

- 1 Specify spindle positioning alone in a block. A move command for the X or Z axis cannot be specified within the same block.
- 2 When emergency stop is applied during spindle positioning, spindle positioning stops. To resume it, restart with the orientation step.
- 3 The serial spindle Cs-axis contour control function and the spindle positioning function cannot be used at a time. If both options are specified, the spindle positioning function has priority.
- 4 The spindle positioning axis is indicated in pulses in the machine coordinate system.

10

TOOL FUNCTION (T FUNCTION)



Two tool functions are available. One is the tool selection function, and the other is the tool life management function.

10.1 TOOL SELECTION

By specifying a 2–digit/4–digit numerical value following address T, a code signal and a strobe signal are transmitted to the machine tool. This is mainly used to select tools on the machine.

One T code can be commanded in a block. Refer to the machine tool builder's manual for the number of digits commandable with address T and the correspondence between the T codes and machine operations.

When a move command and a T code are specified in the same block, the commands are executed in one of the following two ways:

1. Simultaneous execution of the move command and T function commands.
2. Executing T function commands upon completion of move command execution.

The selection of either sequence depends on the machine tool builder's specifications. Refer to the machine tool builder's manual for details.

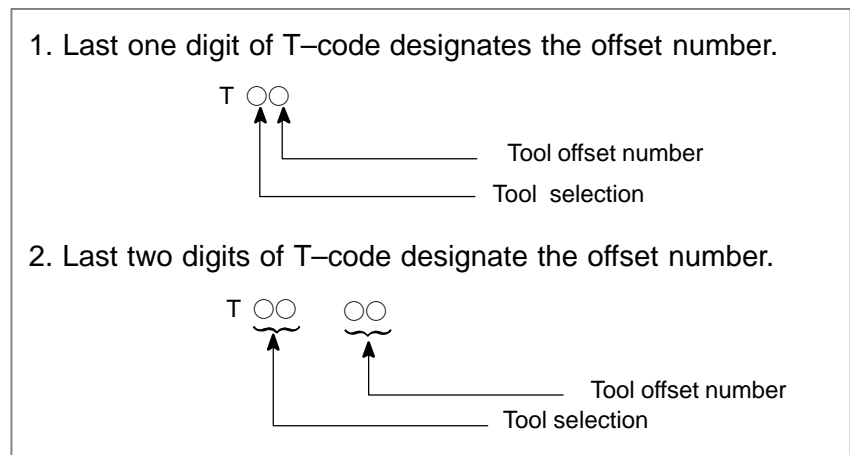

Explanations

The value after the T code indicates the desired tool. Part of the values is also used as the offset number indicating the compensation amount for tool offset.

Refer to the machine tool builder's manual for correspondence between the T–code and the tool and the number of digit to specify tool selection.

Example (T2+2)

N1G00X1000Z1400

N2T0313; (Select Tool No. 3 and Offset value No. 13)

N3X400Z1050;

Some machines use a 1–digit value to specify tool selection.

10.2 TOOL LIFE MANAGEMENT

Tools are classified into some groups. For each group, a tool life (time or frequency of use) is specified. Each time a tool is used, the time for which the tool is used is accumulated. When the tool life has been reached, the next tool previously determined in the same group is used. This function is called the tool life management function.

With 2-path control, tool life management is performed for each tool post separately. So tool life management data is also set for each tool post.

10.2.1 Program of Tool Life Data

Format

Tools used sequentially in each group and their tool life are registered in the CNC as following program format of table 10.2.1 (a).

Table 10.2.1 (a) Program format of life management

Tape format	Meaning
O_____ ;	Program number
G10L3;	Start of setting tool life data
P_____ L_____ ;	P_____ :Group number (1 to 128) L_____ :Tool life (1 to 9999)
T_____ ;	(1) } T:_____ Tool number
T_____ ;	(2) }
⋮	(n) }
P_____ L_____ ;	Tools are selected from (1)to (2) to ... to (n).
T_____ ;	} Data for the next group
T_____ ;	
⋮	
G11;	End of setting tool life data
M02(M30);	End of program

For the method of registering tool life data in CNC, refer to Subsec. III-11.4.14.

Explanations

- **Specification by duration or number of times the tool has been used**

A tool life is specified either as the time of use (in minutes) or the frequency of use, which depends on the parameter setting parameter No. 6800#2 (LTM).
Up to 4300 minutes in time or 9999 times in frequency can be specified for a tool life.

- **Maximum number of groups and tools**

The number of groups to be registered and the number of tools registered per group can be combined in three ways. One of the three combinations is set by a parameter No. 6800#0, #1 (Each GS1 and GS2).

Table 10.2.1 (b) The max. number of groups and tools that can be registered

GS2 (No.6800#1)	GS1 (No.6800#0)	The Max. number of groups and tools without optional function of 128 tool pairs		The Max. number of groups and tools with optional function of 128 tool pairs	
		Number of group	Number of tool	Number of group	Number of tool
0	0	16	16	16	32
0	1	32	8	32	16
1	0	64	4	64	8
1	1	16	16	128	4

In each of the cases listed above, the maximum number of tools which can be registered is 512 or 256 depending, respectively, on whether the option for 128 tool life control groups is used or not. When the option is not used, set the parameters as follows: For up to 16 groups, with up to 16 tools in each group, set GS1 = 0 and GS2 = 0. For up to 32 groups, with up to 8 tools in each group, set GS1 = 0 and GS2 = 1. To change the combination, change the parameter, then set program is executed with the old tool group combination set in the NC. Whenever the parameter is changed, be sure to reexecute the group setting program.

- **A T code for registering tools**

The same tool number may appear anywhere any times in the program of tool life data.

A T code for registering tools can usually consist of up to four digits. When the option for 128 tool life control groups is used, however, it can consist of up to six digits.

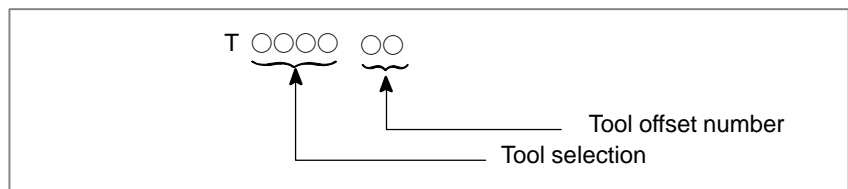

When using the tool life control function, do not use tool position offset parameters LD1 and LGN (bits 0 and 1 of parameter No. 5002).

Example

<pre>O0001 ; G10L3 ; P001L0150 ; T0011 ; T0132 ; T0068 ; P002L1400 ; T0061 ; T0241 ; T0134 ; T0074 ; P003L0700 ; T0012 ; T0202 ; G11 ; M02 ;</pre>	<table border="0"> <tr> <td style="font-size: 2em;">}</td> <td>Data of group 1</td> </tr> <tr> <td style="font-size: 2em;">}</td> <td>Data of group 2</td> </tr> <tr> <td style="font-size: 2em;">}</td> <td>Data of group 3</td> </tr> </table>	}	Data of group 1	}	Data of group 2	}	Data of group 3
}	Data of group 1						
}	Data of group 2						
}	Data of group 3						

Explanations

The group numbers specified in P need not be serial. They need not be assigned to all groups, either. When using two or more offset numbers for the same tool in the same process, set as follows;

Tape format	Meaning
<pre>P004L0500 ; T0101 ; T0105 ; T0108 ; T0206 ; T0203 ; T0202 ; T0209 ; T0304 ; T0309 ; P005L1200 ; T0405 ;</pre>	<p>The tools in group 4 are used from (1) to (2) to (3).</p> <p>(1) Each tool is used 500 times (or for 500 minutes).</p> <p>(2) When this group is specified three times in one process, the offset numbers are selected in the following orders:</p> <p>Tools (1): 01→05→08</p> <p>(3) Tools (2): 06→03→02→09</p> <p>Tools (3): 04→09</p>

10.2.2 Counting a Tool Life

Explanation

- **When a tool life is specified as the time of use (in minutes)**

Between T $\Delta\Delta$ 99($\Delta\Delta$ =Tool group number) and T $\Delta\Delta$ 88 in a machining program, the time for which the tool is used in the cutting mode is counted at intervals of 4 seconds. The time taken for single-block stoppage, feed hold, rapid traverse, dwelling, and FIN wait is ignored.

Up to 4300 minutes can be specified for a life.

- **When a tool life is specified as the frequency of use**

Counting is performed for each process that is initiated by the cycle start of a machining program and ended when the NC is reset by the M02 or M03 command. The counters for tool groups used in a process are incremented by one. Even when the same group is specified more than once in one process, the counter is incremented only by one. Up to 9999 can be set for a tool life.

Counting of a tool life is performed for each group. The life counter contents are not erased even when the power of CNC is cut off.

When a life is specified as the frequency of use, apply an external reset (ERS) signal to the CNC when M02 or M30 is executed.

10.2.3 Specifying a Tool Group in a Machining Program

In machining programs, T codes are used to specify tool groups as follows:

Tape format	Meaning
⋮ TΔΔ99; ⋮ ⋮ ⋮ TΔΔ88; ⋮ ⋮ M02(M300);	<p>Ends the tool used by now, and starts to use the tool of the ΔΔgroup. "99" distinguishes this specification from ordinary specification.</p> <p>Cancels the offset of the tool of the group. "88" distinguishes this specification from ordinary specification.</p> <p>Ends the machining program.</p>

Explanations

Tape format	Meaning
T0199; ⋮	Ends the previous tool, and starts to use the tool of the 01 group.
T0188; ⋮	Cancels the offset of the tool of the 01 group.
T0508; ⋮	Ends the tool of the 01 group. Selects tool number 05 and offset number 08.
T0500; ⋮	Cancels the offset of tool number 05.
T0299; ⋮	Ends tool number 05, and starts to use the tool of the 02 group.
T0199; ⋮ ⋮ ⋮	Ends the tool of the 02 group, and starts to use the tool of the 01 group. If more than one offset number is specified for the tool, the second offset number is selected. Otherwise, the previous offset number is used.

11

AUXILIARY FUNCTION



There are two types of auxiliary functions; miscellaneous function (M code) for specifying spindle start, spindle stop program end, and so on, and secondary auxiliary function (B code).

When a move command and miscellaneous function are specified in the same block, the commands are executed in one of the following two ways:

- i) Simultaneous execution of the move command and miscellaneous function commands.
- ii) Executing miscellaneous function commands upon completion of move command execution.

The selection of either sequence depends on the machine tool builder's specification. Refer to the manual issued by the machine tool builder for details.

11.1 AUXILIARY FUNCTION (M FUNCTION)

When address M followed by a number is specified, a code signal and strobe signal are transmitted. These signals are used for turning on/off the power to the machine.

In general, only one M code is valid in a block but up to three M codes can be specified in a block (although some machines may not allow that). The correspondence between M codes and functions is up to the machine tool builder.

All M codes are processed in the machine except for M98, M99, M198, M codes for calling a subprogram (parameters Nos. 6071 to 6079), and M codes for calling a custom macro (parameters Nos. 6080 to 6089). Refer to the appropriate manual issued by the machine tool builder.

Explanations

- **M02, M03**
(End of program)

The following M codes have special meanings.

This indicates the end of the main program. Automatic operation is stopped and the CNC unit is reset. This differs with the machine tool builder. After a block specifying the end of the program is executed, control returns to the start of the program. Bit 5 of parameter No. 3404 (M02) or bit 4 of parameter No. 3404 (M03) can be used to disable M02 or M03 from returning control to the start of the program.

- **M00**
(Program stop)

Automatic operation is stopped after a block containing M00 is executed. When the program is stopped, all existing modal information remains unchanged. The automatic operation can be restarted by actuating the cycle operation. This differs with the machine tool builder.

- **M01**
(Optional stop)

Similarly to M00, automatic operation is stopped after a block containing M01 is executed. This code is only effective when the Optional Stop switch on the machine operator's panel has been pressed.

- **M98**
(Calling of subprogram)

This code is used to call a subprogram. The code and strobe signals are not sent. See the subprogram section II-13.3 for details.

- **M99**
(End of subprogram)

This code indicates the end of a subprogram. M99 execution returns control to the main program. No code or strobe signal is sent. See the subprogram section II-13.3 for details.

- **M198**
(Calling a subprogram)

This code is used to call a subprogram of a file in the external input/output function. See the description of the subprogram call function (III-4.5) for details.

NOTE

A block immediately after an M00, M01, M02, or M03 block is not buffered. Similarly, ten M codes which do not buffer can be set by parameters (Nos. 3411 to 3421). Refer to the machine tool builder's instruction manual for these M codes.

11.2 MULTIPLE M COMMANDS IN A SINGLE BLOCK

So far, one block has been able to contain only one M code. Up to three M codes can be specified in a single block when bit 7 (M3B) of parameter No. 3404 is set to 1.

Up to three M codes specified in a block are simultaneously output to the machine. This means that compared with the conventional method of a single M command in a single block, a shorter cycle time can be realized in machining.

Explanations

CNC allows up to three M codes to be specified in one block. However, some M codes cannot be specified at the same time due to mechanical operation restrictions. For detailed information about the mechanical operation restrictions on simultaneous specification of multiple M codes in one block, refer to the manual of each machine tool builder.

M00, M01, M02, M30, M98, M99, or M198 must not be specified together with another M code.

Some M codes other than M00, M01, M02, M30, M98, M99, and M198 cannot be specified together with other M codes; each of those M codes must be specified in a single block.

Such M codes include these which direct the CNC to perform internal operations in addition to sending the M codes themselves to the machine. To be specified, such M codes are M codes for calling program numbers 9001 to 9009 and M codes for disabling advance reading (buffering) of subsequent blocks. Meanwhile, multiple of M codes that direct the CNC only to send the M codes themselves (without performing internal operations) can be specified in a single block.

Examples

One M command in a single block	Multiple M commands in a single block
M40 ;	M40M50M60 ;
M50 ;	G28G91X0Z0 ;
M60 ;	:
G28G91X0Z0 ;	:
:	:
:	:
:	:

11.3 M CODE GROUP CHECK FUNCTION

The M code group check function checks if a combination of multiple M codes (up to three M codes) contained in a block is correct.

This function has two purposes. One is to detect if any of the multiple M codes specified in a block include an M code that must be specified alone. The other purpose is to detect if any of the multiple M codes specified in a block include M codes that belong to the same group. In either of these cases, P/S alarm No. 5016 is issued.

For details on group data setting, refer to the manual available from the machine tool builder.

Explanations

- **M code setting**
- **Group numbers**

Up to 500 M codes can be specified. In general, M0 to M99 are always specified. M codes from M100 and up are optional.

Group numbers can be set from 0 to 127. Note, however, that 0 and 1 have special meanings. Group number 0 represents M codes that need not be checked. Group number 1 represents M codes that must be specified alone.

11.4 THE SECOND AUXILIARY FUNCTIONS (B CODES)

Indexing of the table is performed by address B and a following 8-digit number. The relationship between B codes and the corresponding indexing differs between machine tool builders.

Refer to the manual issued by the machine tool builder for details.

Explanations

- **Command range**

0 to 99999999

- **Command method**

1. The decimal point can be used for input.

Command	Output value
B10.	10000
B10	10

2. It is possible to change over the scale factor of B output, 1000 or 1 when the decimal point input is omitted, using the parameter DPI (No. 3401#0).

Command	Output value
When DPI is 1: B1	1000
When DPI is 0: B1	1

3. It is possible to change over the scale factor of B output 1000 or 10000 when the decimal point input is omitted in the inch input system, using the parameter AUX (No. 3405#0) When DPI=1.

Command	Output value
When AUX is 1: B1	10000
When AUX is 0: B1	1000

Restrictions

When this functions is used, the B address specifying an axis movement disabled.

12 PROGRAM CONFIGURATION

General

- **Main program and subprogram**

There are two program types, main program and subprogram. Normally, the CNC operates according to the main program. However, when a command calling a subprogram is encountered in the main program, control is passed to the subprogram. When a command specifying a return to the main program is encountered in a subprogram, control is returned to the main program.

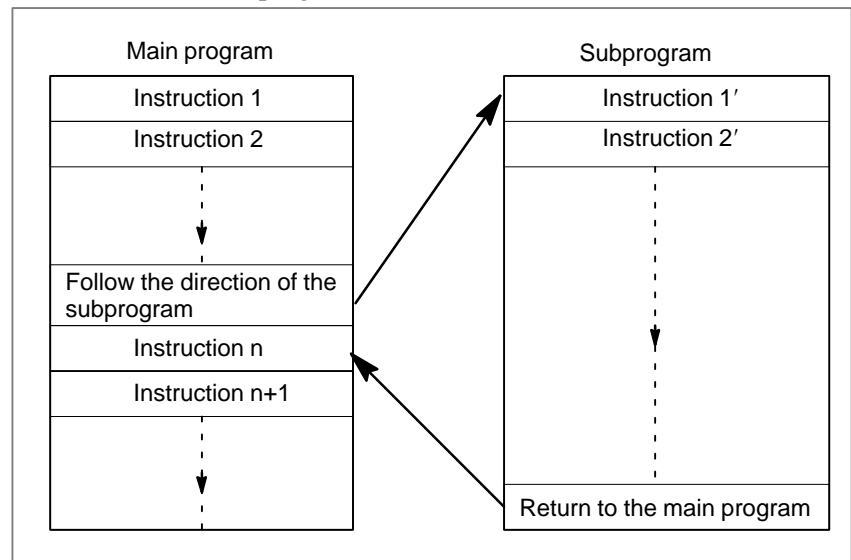

Fig. 12 (a) Main program and Subprogram

The CNC memory can hold up to 400 main programs and subprograms (63 as standard). A main program can be selected from the stored main programs to operate the machine. See III-10 and III-9.3 for the methods of registering and selecting programs.

● **Program components**

A program consists of the following components:

Table 12 Program components

Components	Descriptions
Tape start	Symbol indicating the start of a program file
Leader section	Used for the title of a program file, etc.
Program start	Symbol indicating the start of a program
Program section	Commands for machining
Comment section	Comments or directions for the operator
Tape end	Symbol indicating the end of a program file

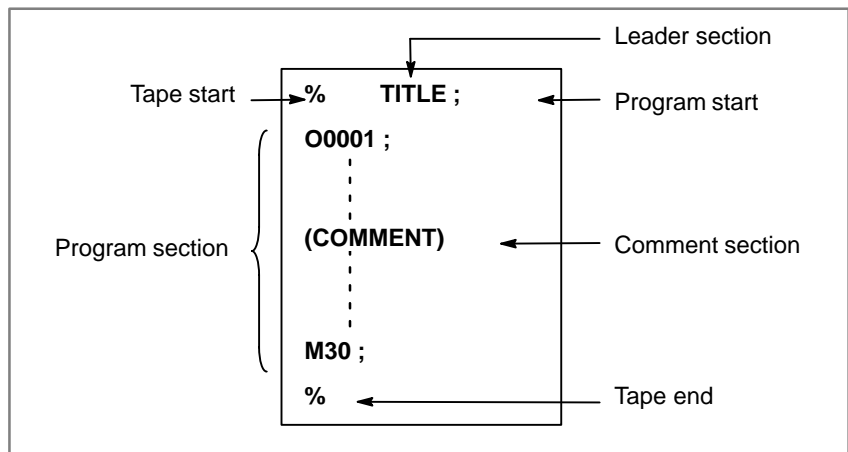

Fig. 12 (b) Program configuration

● **Program section configuration**

A program section consists of several blocks. A program section starts with a program number and ends with a program end code.

<u>Program section configuration</u>	<u>Program section</u>
Program number	O0001 ;
Block 1	N1 G91 G00 X120.0 Y80.0 ;
Block 2	N2 G43 Z-32.0 H01 ;
:	:
Block n	Nn Z0 ;
Program end	M30 ;

A block contains information necessary for machining, such as a move command or coolant on/off command. Specifying a value following a slash (/) at the start of a block disables the execution of some blocks (see “optional block skip” in Section II-12.2).

12.1 PROGRAM COMPONENTS OTHER THAN PROGRAM SECTIONS

This section describes program components other than program sections. See Section II-12.2 for a program section.

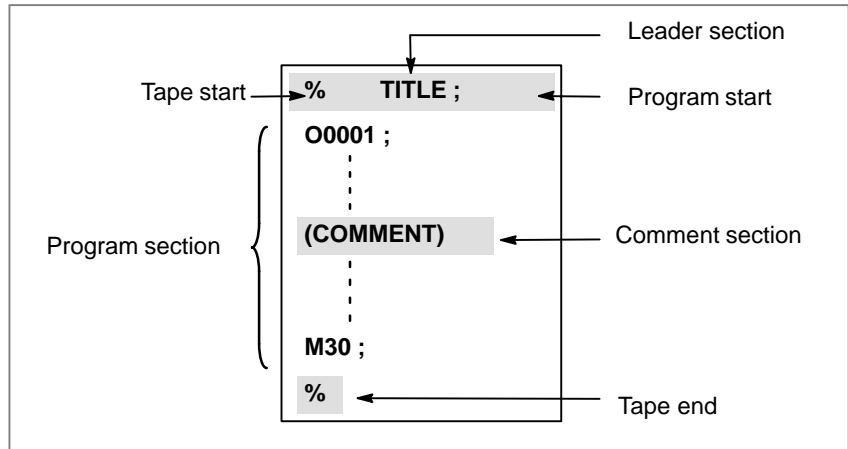

Fig. 12.1 Program configuration

Explanations

- **Tape start**

The tape start indicates the start of a file that contains CNC programs. The mark is not required when programs are entered using SYSTEM P or ordinary personal computers. The mark is not displayed on the display screen. However, if the file is output, the mark is automatically output at the start of the file.

Table 12.1 (a) Code of a tape start

Name	ISO code	EIA code	Notation in this manual
Tape start	%	ER	%

- **Leader section**

Data entered before the programs in a file constitutes a leader section. When machining is started, the label skip state is usually set by turning on the power or resetting the system. In the label skip state, all information is ignored until the first end-of-block code is read. When a file is read into the CNC unit from an I/O device, leader sections are skipped by the label skip function.

A leader section generally contains information such as a file header. When a leader section is skipped, even a TV parity check is not made. So a leader section can contain any codes except the EOB code.

- **Program start**

The program start code is to be entered immediately after a leader section, that is, immediately before a program section. This code indicates the start of a program, and is always required to disable the label skip function.

With SYSTEM P or ordinary personal computers, this code can be entered by pressing the return key.

Table 12.1 (b) Code of a program start

Name	ISO code	EIA code	Notation in this manual
Program start	LF	CR	;

NOTE

If one file contains multiple programs, the EOB code for label skip operation must not appear before a second or subsequent program number. However, an program start is required at the start of a program if the preceding program ends with %.

- **Comment section**

Any information enclosed by the control-out and control-in codes is regarded as a comment and skipped by the CNC. The user can enter a header, comments, directions to the operator, etc. There is no limit on the length of a comment section.

Table 12.1 (c) Codes of a control-in and a control-out

Name	ISO code	EIA code	Notation in this manual	Meaning
Control-out	(2-4-5	(Start of comment section
Control-in)	2-4-7)	End of comment section

When a program is read into memory for memory operation, comment sections, if any, are not ignored but are also read into memory. Note, however, that codes other than those listed in the code table in Appendix F are ignored, and thus are not read into memory. When the program in this memory is output to an external input/output device (see Section III-8), any comments are also output.

When a program is displayed on the screen, its comment sections are also displayed. However, those codes that were ignored when read into memory are not outputted or displayed.

During memory operation or DNC operation, all comment sections are ignored.

The TV check function can be used for a comment section by setting parameter CTV (bit 1 of No. 0100).

CAUTION

If a long comment section appears in the middle of a program section, a move along an axis may be suspended for a long time because of such a comment section. So a comment section should be placed where movement suspension may occur or no movement is involved.

NOTE

- 1 If only a control-in code is read with no matching control-out code, the read control-in code is ignored.
- 2 The EOB code cannot be used in a comment.

- **Tape end**

A tape end is to be placed at the end of a file containing NC programs. If programs are entered using the automatic programming system, the mark need not be entered. The mark is not displayed on the CRT display screen. However, when a file is output, the mark is automatically output at the end of the file.

If an attempt is made to execute % when M02 or M03 is not placed at the end of the program, the P/S alarm (No. 5010) is occurred.

Table 12.1 (d) Code of a tape end

Name	ISO code	EIA code	Notation in this manual
Tape end	%	ER	%

12.2 PROGRAM SECTION CONFIGURATION

This section describes elements of a program section. See Section II-12.1 for program components other than program sections.

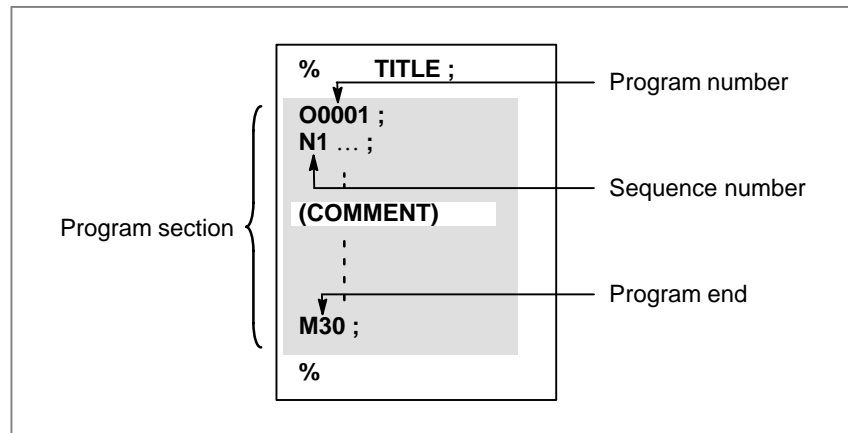

Fig. 12.2 (a) Program configuration

- Program number

A program number consisting of address O followed by a four-digit number is assigned to each program at the beginning registered in memory to identify the program.

When the 8-digit program number option is used, however, specify eight digits for the program number (see Section II.12.4).

In ISO code, the colon (:) can be used instead of O.

When no program number is specified at the start of a program, the sequence number (N....) at the start of the program is regarded as its program number. If a five-digit sequence number is used, the lower four digits are registered as a program number. If the lower four digits are all 0, the program number registered immediately before added to 1 is registered as a program number. Note, however, that N0 cannot be used for a program number.

If there is no program number or sequence number at the start of a program, a program number must be specified using the MDI panel when the program is stored in memory (See Section 8.4 or 10.1 in Part III.).

NOTE

Program numbers 8000 to 9999 may be used by machine tool builders, and the user may not be able to use these numbers.

- **Sequence number and block**

A program consists of several commands. One command unit is called a block. One block is separated from another with an EOB of end of block code.

Table 12.2 (a) EOB code

Name	ISO code	EIA code	Notation in this manual
End of block (EOB)	LF	CR	;

At the head of a block, a sequence number consisting of address N followed by a number not longer than five digits (1 to 99999) can be placed. Sequence numbers can be specified in a random order, and any numbers can be skipped. Sequence numbers may be specified for all blocks or only for desired blocks of the program. In general, however, it is convenient to assign sequence numbers in ascending order in phase with the machining steps (for example, when a new tool is used by tool replacement, and machining proceeds to a new surface with table indexing.)

N300 X200.0 Z300.0 ; A sequence number is underlined.

Fig. 12.2 (b) Sequence number and block (example)

NOTE

N0 must not be used for the reason of file compatibility with other CNC systems.

Program number 0 cannot be used. So 0 must not be used for a sequence number regarded as a program number.

- **TV check (Vertical parity check along tape)**

A parity check is made for a block on input tape vertically. If the number of characters in one block (starting with the code immediately after an EOB and ending with the next EOB) is odd, an P/S alarm (No.002) is output. No TV check is made only for those parts that are skipped by the label skip function. Bit 1 (CTV) of parameter No. 0100 can be used to specify whether the characters constituting comments, enclosed in “(” and “)”, are counted when obtaining the number of characters for TV check. The TV check function can be enabled or disabled by setting on the MDI unit (See subsec. 11.4.7 in Part III.).

- **Block configuration (word and address)**

A block consists of one or more words. A word consists of an address followed by a number some digits long. (The plus sign (+) or minus sign (-) may be prefixed to a number.)

Word = Address + number (Example : X-1000)

For an address, one of the letters (A to Z) is used ; an address defines the meaning of a number that follows the address. Table 12.2 (b) indicates the usable addresses and their meanings.

The same address may have different meanings, depending on the preparatory function specification.

Table 12.2 (b) Major functions and addresses

Function	Address	Meaning
Program number	O ⁽¹⁾	Program number
Sequence number	N	Sequence number
Preparatory function	G	Specifies a motion mode (linear, arc, etc.)
Dimension word	X, Y, Z, U, V, W, A, B, C	Coordinate axis move command
	I, J, K	Coordinate of the arc center
	R	Arc radius
Feed function	F	Rate of feed per minute, Rate of feed per revolution
Spindle speed function	S	Spindle speed
Tool function	T	Tool number
Auxiliary function	M	On/off control on the machine tool
	B	Table indexing, etc.
Dwell	P, X, U	Dwell time
Program number designation	P	Subprogram number
Number of repetitions	P	Number of subprogram repetitions
Parameter	P, Q	Canned cycle parameter

NOTE

In ISO code, the colon (:) can also be used as the address of a program number.

N_	G_	X_ Z_	F_	S_	T_	M_	;
Se- quence number	Preparatory function	Dimension word	Feed- function	Spindle speed function	Tool func- tion	Miscella- neous func- tion	

Fig. 12.2 (c) 1 block (example)

- **Major addresses and ranges of command values**

Major addresses and the ranges of values specified for the addresses are shown below. Note that these figures represent limits on the CNC side, which are totally different from limits on the machine tool side. For example, the CNC allows a tool to traverse up to about 100 m (in millimeter input) along the X axis.

However, an actual stroke along the X axis may be limited to 2 m for a specific machine tool.

Similarly, the CNC may be able to control a cutting federate of up to 240 m/min, but the machine tool may not allow more than 3 m/min. When developing a program, the user should carefully read the manuals of the machine tool as well as this manual to be familiar with the restrictions on programming.

Table 12.2 (c) Major addresses and ranges of command values

Function		Address	Input in mm	Input in inch
Program number		O ⁽¹⁾	1-9999	1-9999
Sequence number		N	1-99999	1-99999
Preparatory function		G	0-99	0-99
Dimension word	Increment system IS-B	X, Y, Z, U, V, W, A, B, C, I, J, K, R,	-99999.999 to +99999.999	-9999.9999 to +9999.9999
	Increment system IS-C		-9999.9999 to +9999.9999	-999.99999 to +999.99999
Feed per minute	Increment system IS-B	F	1 to 240000 mm/min	0.01 to 9600.00 inch/min
	Increment system IS-C		1 to 100000 mm/min	0.01 to 4000.00 inch/min
Feed per revolution		F	0.0001 to 500.0000 mm/rev	0.000001 to 9.999999 inch/rev
Spindle speed function		S	0 to 20000	0 to 20000
Tool function		T	0 to 99999999	0 to 99999999
Auxiliary function		M	0 to 99999999	0 to 99999999
		B	0 to 99999999	0 to 99999999
Dwell	Increment system IS-B	P, X, U	0 to 99999.999s	0 to 99999.999s
	Increment system IS-C		0 to 9999.9999s	0 to 9999.9999s
Designation of a program number		P	1 to 9999	1 to 9999
Number of repetitions		P	1 to 999	1 to 999

NOTE

In ISO code, the colon (:) can also be used as the address of a program number.

- **Optional block skip**

When a slash followed by a number (/n (n=1 to 9)) is specified at the head of a block, and optional block skip switch n on the machine operator panel is set to on, the information contained in the block for which /n corresponding to switch number n is specified is ignored in tape operation or memory operation.

When optional block skip switch n is set to off, the information contained in the block for which /n is specified is valid. This means that the operator can determine whether to skip the block containing /n.

Number 1 for /1 can be omitted. However, when two or more optional block skip switches are used for one block, number 1 for /1 cannot be omitted.

Example)

(Incorrect) (Correct)
//3 G00X10.0; /1/3 G00X10.0;

This function is ignored when programs are loaded into memory. Blocks containing /n are also stored in memory, regardless of how the optional block skip switch is set.

Programs held in memory can be output, regardless of how the optional block skip switches are set.

Optional block skip is effective even during sequence number search operation.

Depending on the machine tool, all optional block skip switches (1 to 9) may not be usable. Refer to manuals of the machine tool builder to find which switches are usable.

WARNING

1 Position of a slash

A slash (/) must be specified at the head of a block. If a slash is placed elsewhere, the information from the slash to immediately before the EOB code is ignored.

2 Disabling an optional block skip switch

Optional block skip operation is processed when blocks are read from memory or tape into a buffer. Even if a switch is set to on after blocks are read into a buffer, the blocks already read are not ignored.

NOTE

TV and TH check

When an optional block skip switch is on, TH and TV checks are made for the skipped portions in the same way as when the optional block skip switch is off.

- **Program end**

The end of a program is indicated by punching one of the following codes at the end of the program:

Table 12.2 (d) Code of a program end

Code	Meaning usage
M02	For main program
M30	
M99	For subprogram

If one of the program end codes is executed in program execution, the CNC terminates the execution of the program, and the reset state is set. When the subprogram end code is executed, control returns to the program that called the subprogram.

WARNING

A block containing an optional block skip code such as /M02 ; , /M30 ; , or /M99 ; is not regarded as the end of a program, if the optional block skip switch on the machine operator's panel is set to on.
(See item "Optional block skip".)

12.3 SUBPROGRAM (M98, M99)

If a program contains a fixed sequence or frequently repeated pattern, such a sequence or pattern can be stored as a subprogram in memory to simplify the program.

A subprogram can be called from the main program.

A called subprogram can also call another subprogram.

Format

- Subprogram configuration

One subprogram

O □□□□ ; : : : M99 ;	Subprogram number (or the colon (:)) optionally in the case of ISO
------------------------------------	--

Program end

M99 need not constitute a separate block as indicated below.
Example) X100.0 Y100.0 M99 ;

- Subprogram call (M98)

M98 P ○○○○ ○○○○ ;

↑	↑
Number of times the subprogram is called repeatedly	Subprogram number

When no repetition data is specified, the subprogram is called just once.

Explanations

When the main program calls a subprogram, it is regarded as a one-level subprogram call. Thus, subprogram calls can be nested up to four levels as shown below.

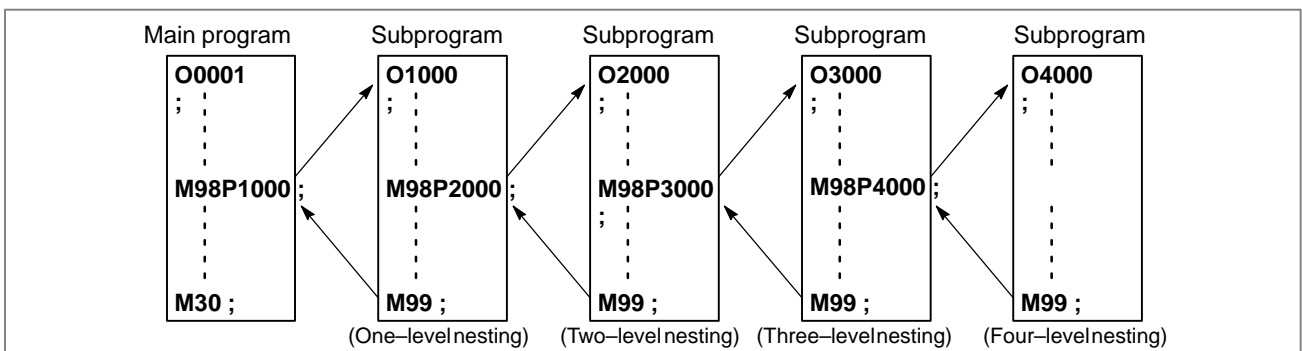

A single call command can repeatedly call a subprogram up to 9999 times. For compatibility with automatic programming systems, in the first block, Nxxxx can be used instead of a subprogram number that follows O (or :). A sequence number after N is registered as a subprogram number.

Reference item

See Chapter 10 in Part III for the method of registering a subprogram.

NOTE

- 1 The M98 and M99 signals are not output to the machine tool.
- 2 If the subprogram number specified by address P cannot be found, an alarm (No. 078) is output.

Examples

☆ **M98 P51002 ;**

This command specifies "Call the subprogram (number 1002) five times in succession." A subprogram call command (M98P_) can be specified in the same block as a move command.

☆ **X1000.0 M98 P1200 ;**

This example calls the subprogram (number 1200) after an X movement.

☆ Execution sequence of subprograms called from a main program

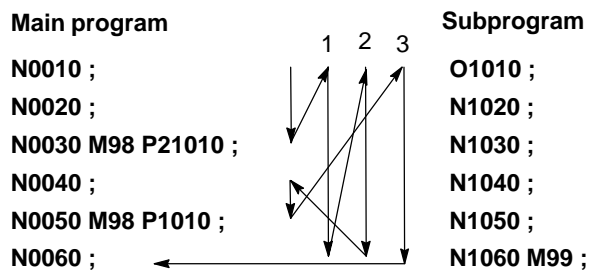

A subprogram can call another subprogram in the same way as a main program calls a subprogram.

Special Usage

- **Specifying the sequence number for the return destination in the main program**

If P is used to specify a sequence number when a subprogram is terminated, control does not return to the block after the calling block, but returns to the block with the sequence number specified by P. Note, however, that P is ignored if the main program is operating in a mode other than memory operation mode.

This method consumes a much longer time than the normal return method to return to the main program.

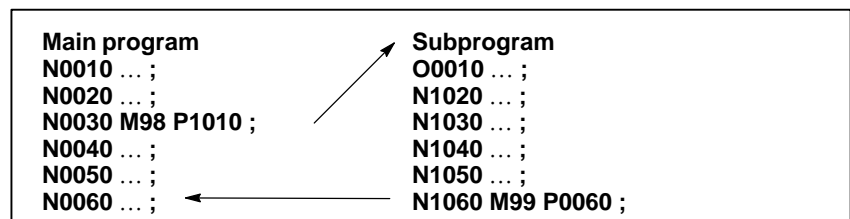

- **Using M99 in the main program**

If M99 is executed in a main program, control returns to the start of the main program. For example, M99 can be executed by placing /M99 ; at an appropriate location of the main program and setting the optional block skip function to off when executing the main program. When M99 is executed, control returns to the start of the main program, then execution is repeated starting at the head of the main program.

Execution is repeated while the optional block skip function is set to off. If the optional block skip function is set to on, the /M99 ; block is skipped; control is passed to the next block for continued execution.

If /M99P_n ; is specified, control returns not to the start of the main program, but to sequence number n. In this case, a longer time is required to return to sequence number n.

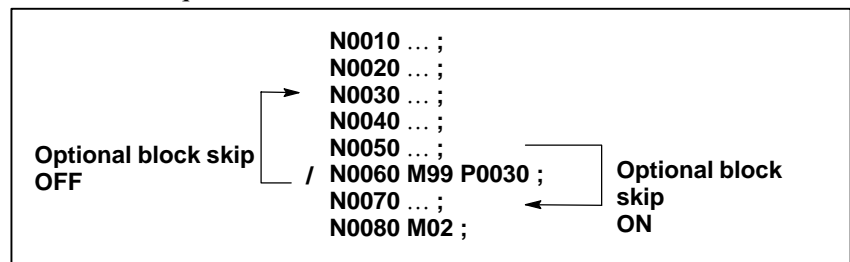

- **Using a subprogram only**

A subprogram can be executed just like a main program by searching for the start of the subprogram with the MDI.

(See Section 9.4 in Part III for information about search operation.)

In this case, if a block containing M99 is executed, control returns to the start of the subprogram for repeated execution. If a block containing M99P_n is executed, control returns to the block with sequence number n in the subprogram for repeated execution. To terminate this program, a block containing /M02 ; or /M30 ; must be placed at an appropriate location, and the optional block switch must be set to off ; this switch is to be set to on first.

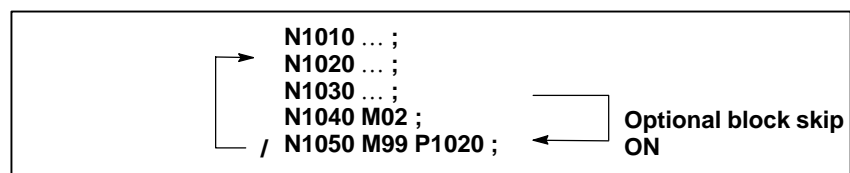

12.4 8-DIGIT PROGRAM NUMBER

The 8-digit program number function enables specification of program numbers with eight digits following address O (O00000001 to O99999999).

Explanations

- **Inhibiting editing of programs**

Editing of subprograms O00008000 to O00008999, O00009000 to O00009999, O80000000 to O89999999, and O90000000 to O99999999 can be inhibited.

Parameter	Program numbers for which editing is disabled
NE8(No.3202#0)	O00008000 to O00008999
NE9(No.3202#4)	O00009000 to O00009999
PRG8E(No.3204#3)	O80000000 to O89999999
PRG9E(No.3204#4)	O90000000 to O99999999

NOTE

When a wrong password has been specified for the password function (see III-9.9), the settings of NE9 (bit 3 of parameter No. 3202) and PQE (bit 4 of parameter No. 3204) cannot be changed.

- **File name**

For program punch by specifying a range, files are named as follows:

When punching by specifying O00000001 and O00123456:
“O00000001-G”

When punching by specifying O12345678 and O45678900:
“O12345678-G”

When 2-path control is being applied, the file name for the first path is

suffixed with “-1” and that for the second path is suffixed with “-2.”

- **Special programs**

Special subprogram numbers can be changed by using bit 5 (SPR) of parameter No. 3204.

1) Macro call using G code

Parameter used to specify G code	Program number	
	When SPR = 0	When SPR = 1
No.6050	O00009010	O90009010
No.6051	O00009011	O90009011
No.6052	O00009012	O90009012
No.6053	O00009013	O90009013
No.6054	O00009014	O90009014
No.6055	O00009015	O90009015
No.6056	O00009016	O90009016
No.6057	O00009017	O90009017
No.6058	O00009018	O90009018
No.6059	O00009019	O90009019

2) Macro call using M code

Parameter used to specify M code	Program number	
	When SPR = 0	When SPR = 1
No.6080	O00009020	O90009020
No.6081	O00009021	O90009021
No.6082	O00009022	O90009022
No.6083	O00009023	O90009023
No.6084	O00009024	O90009024
No.6085	O00009025	O90009025
No.6086	O00009026	O90009026
No.6087	O00009027	O90009027
No.6088	O00009028	O90009028
No.6089	O00009029	O90009029

3) Subprogram call using M code

Parameter used to specify M code	Program number	
	When SPR = 0	When SPR = 1
No.6071	O00009001	O90009001
No.6072	O00009002	O90009002
No.6073	O00009003	O90009003
No.6074	O00009004	O90009004
No.6075	O00009005	O90009005
No.6076	O00009006	O90009006
No.6077	O00009007	O90009007
No.6078	O00009008	O90009008
No.6079	O00009009	O90009009

4) Macro call using T code

Parameter used to specify T code	Program number	
	When SPR = 0	When SPR = 1
TCS(No.6001#5)	O00009000	O90009000

5) Macro call using ASCII code

Parameter used to specify ASCII code	Program number	
	When SPR = 0	When SPR = 1
No.6090	O00009004	O90009004
No.6091	O00009005	O90009005

6) Pattern data function

Program number	
When SPR = 0	When SPR = 1
O00009500	O90009500
O00009501	O90009501
O00009502	O90009502
O00009503	O90009503
O00009504	O90009504
O00009505	O90009505
O00009506	O90009506
O00009507	O90009507
O00009508	O90009508
O00009509	O90009509
O00009510	O90009510

- **External program number search**

External input signals can be used to search for a program number. A program stored in CNC memory can be selected by externally inputting a program number, between 1 and 99999999, to the CNC. For details, refer to the appropriate manual supplied from the machine tool builder.

Limitations

- **Subprogram call**

This function disables subprogram call unless FS15 tape format (see II-19) is used. This restriction also applies to calling a program in external I/O devices (M198).

(Example)

```
M98 P12345678 ;
```

└── Subprogram number only

The repetition count is not included.

- **DNC**

O8-digit program number can not be used in DNC1, DNC2, ethernet, data server, OPEN CNC, CONVERSATIONAL AUTOMATIC PROGRAMMING FUNCTION.

13

FUNCTIONS TO SIMPLIFY PROGRAMMING

General

This chapter explains the following items:

13.1 CANNED CYCLE (G90, G92, G94)

13.2 MULTIPLE REPETITIVE CYCLE (G70–G76)

13.3 CANNED CYCLE FOR DRILLING (G80–G89)

**13.4 CANNED GRINDING CYCLE
(FOR GRINDING MACHINE)**

13.5 CHAMFERING AND CORNER R

13.6 MIRROR IMAGE FOR DOUBLE TURRET (G68, G69)

13.7 DIRECT DRAWING DIMENSIONS PROGRAMMING

13.8 RIGID TAPPING

**13.9 THREE-DIMENSIONAL COORDINATE CONVERSION
(G68.1, G69.1)**

NOTE

Explanatory diagrams in this chapter uses diameter programming in X axis.
In radius programming, changes U/2 with U and X/2 with X.

13.1 CANNED CYCLE (G90, G92, G94)

There are three canned cycles : the outer diameter/internal diameter cutting canned cycle (G90), the thread cutting canned cycle (G92), and the end face turning canned cycle (G94).

13.1.1 Outer Diameter / Internal Diameter Cutting Cycle (G90)

- Straight cutting cycle

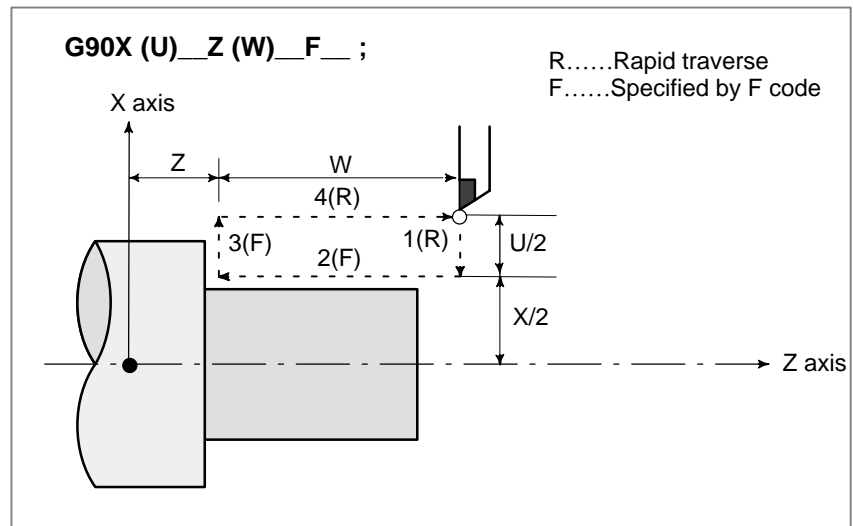

Fig. 13.1.1 (a) Straight Cutting Cycle

In incremental programming, the sign of the numbers following address U and W depends on the direction of paths 1 and 2. In the cycle of Fig. 13.1.1 (a), the signs of U and W are negative.

In single block mode, operations 1, 2, 3 and 4 are performed by pressing the cycle start button once.

• Taper cutting cycle

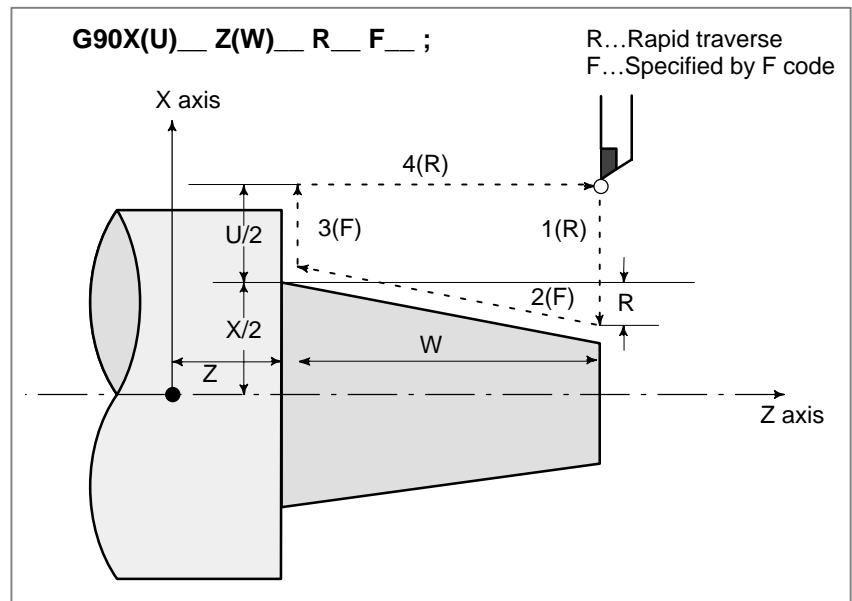

Fig. 13.1.1 (b) Taper Cutting Cycle

• Signs of numbers specified in the taper cutting cycle

In incremental programming, the relationship between the signs of the numbers following address U, W, and R, and the tool paths are as follows:

1. $U < 0, W < 0, R < 0$	2. $U > 0, W < 0, R > 0$
3. $U < 0, W < 0, R > 0$ at $ R \leq \frac{ U }{2}$	4. $U > 0, W < 0, R < 0$ at $ R \leq \frac{ U }{2}$

**13.1.2
Thread Cutting Cycle
(G92)**

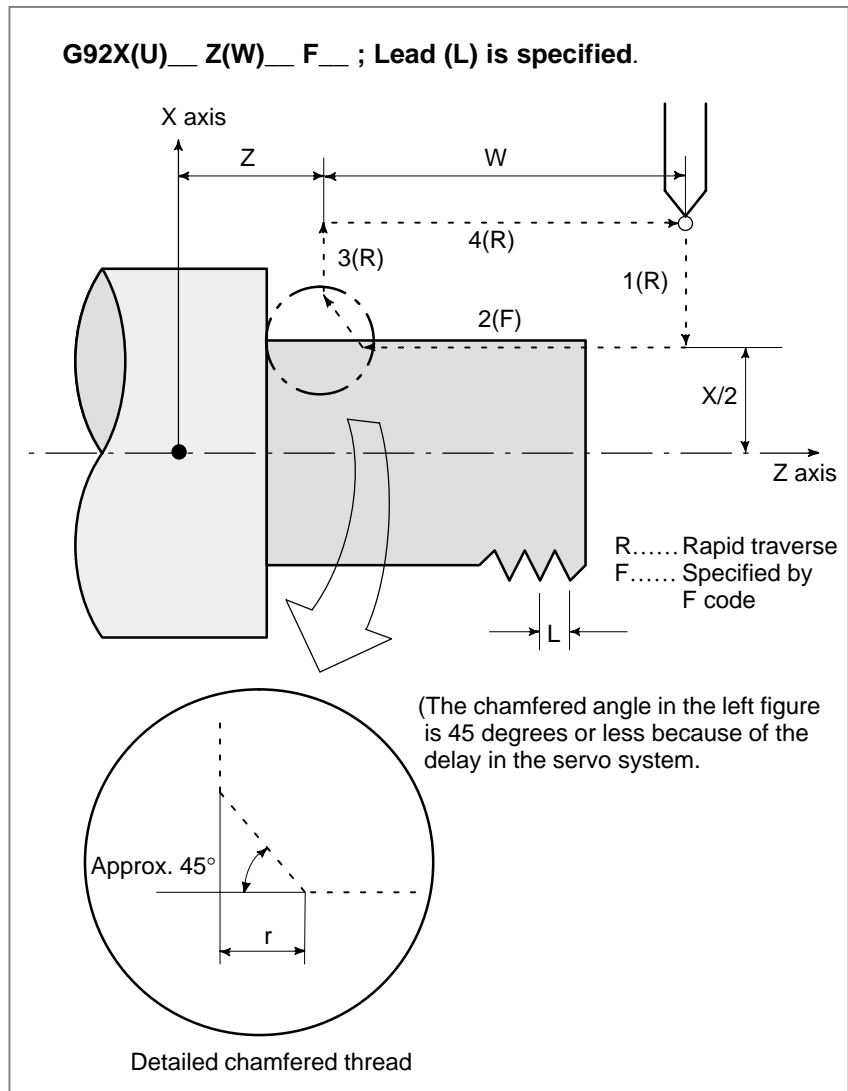

Fig. 13.1.2 (a) Straight Thread Cutting

In incremental programming, the sign of numbers following addresses U and W depends on the direction of paths 1 and 2. That is, if the direction of path 1 is the negative along the X axis, the value of U is negative.

The range of thread leads, limitation of spindle speed, etc. are the same as in G32 (thread cutting). Thread chamfering can be performed in this thread cutting cycle. A signal from the machine tool, initiates thread chamfering. The chamfering distance is specified in a range from 0.1L to 12.7L in 0.1L increments by parameter (No. 5130). (In the above expression, L is the thread lead.)

In the single block mode, operations 1, 2, 3, and 4 are performed by pressing cycle start button once.

WARNING

Notes on this thread cutting are the same as in thread cutting in G32. However, a stop by feed hold is as follows; Stop after completion of path 3 of thread cutting cycle.

CAUTION

The tool retreats while chamfering and returns to the start point on the X axis then the Z axis, as soon as the feed hold status is entered during thread cutting (motion 2) when the "Thread Cutting Cycle retract" option is used.

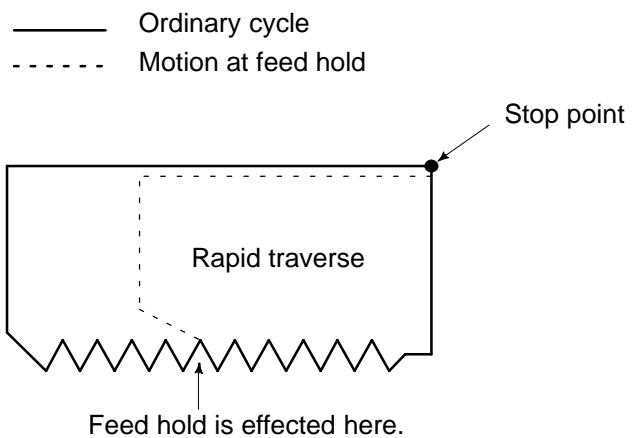

Another feed hold cannot be made during retreat. The chamfered amount is the same as that at the end point.

● Taper thread cutting cycle

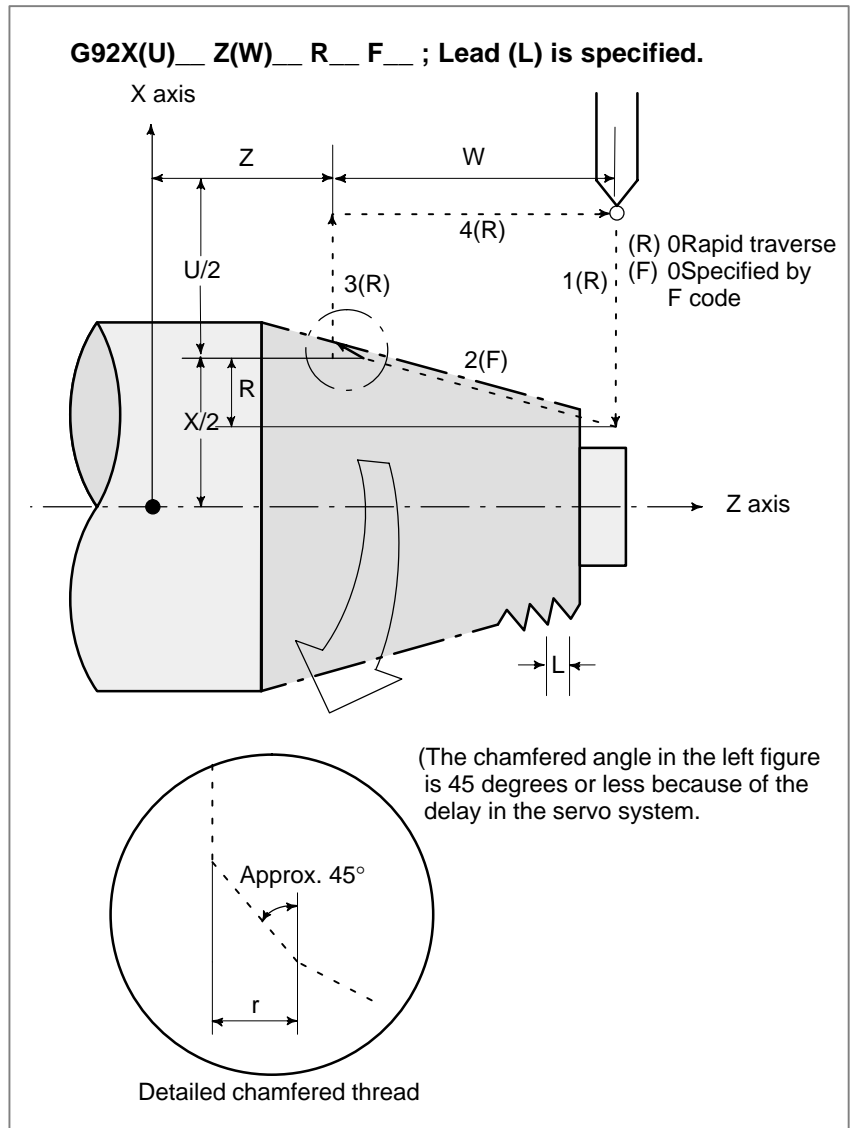

Fig. 13.1.2 (b) Taper thread cutting cycle

13.1.3 End Face Turning Cycle (G94)

- Face cutting cycle

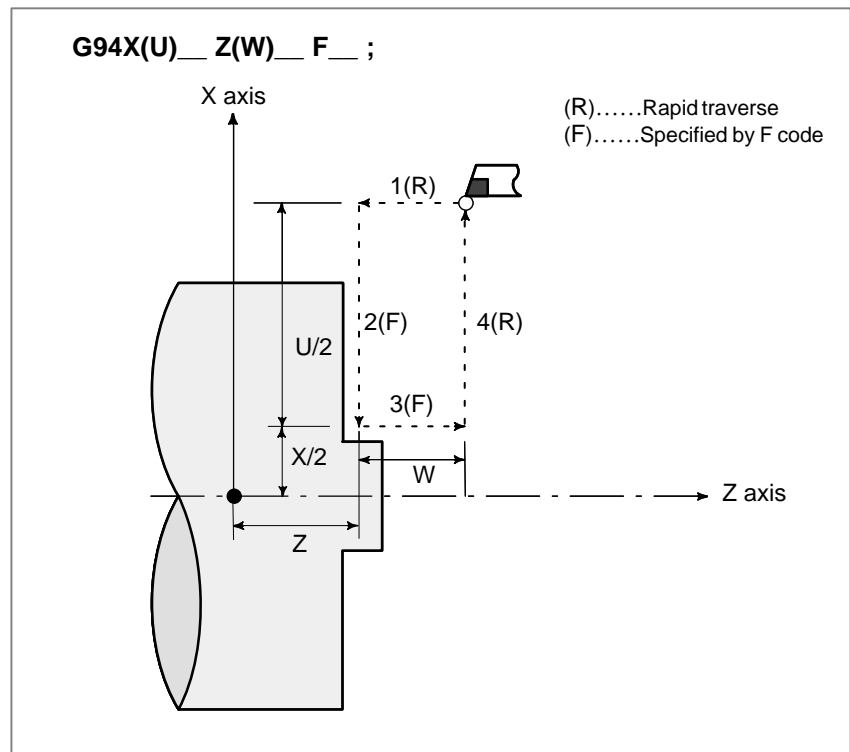

Fig. 13.1.3 (a) Face Cutting Cycle

In incremental programming, the sign of numbers following addresses U and W depends on the direction of paths 1 and 2. That is, if the direction of the path is in the negative direction of the Z axis, the value of W is negative.

In single block mode, operations 1, 2, 3, and 4 are performed by pressing the cycle start button once.

● Taper face cutting cycle

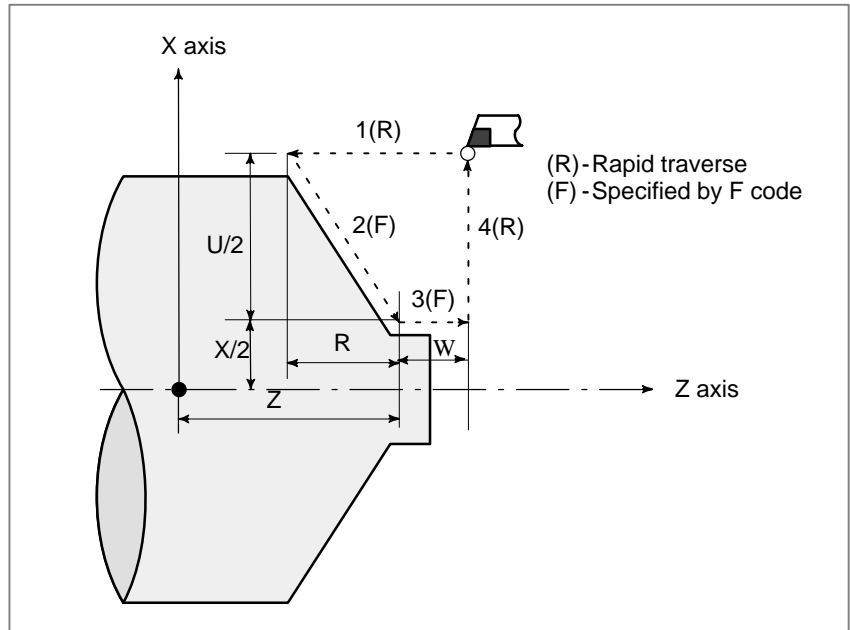

Fig. 13.1.3 (b)

● Signs of numbers specified in the taper cutting cycle

In incremental programming, the relationship between the signs of the numbers following address U, W, and R, and the tool paths are as follows:

<p>1. $U < 0, W < 0, R < 0$</p>	<p>2. $U > 0, W < 0, R < 0$</p>
<p>3. $U < 0, W < 0, R > 0$ at $R \leq W$</p>	<p>4. $U > 0, W < 0, R < 0$ at $R \leq W$</p>

NOTE

1 Since data values of X (U), Z (W) and R during canned cycle are modal, if X (U), Z (W), or R is not newly commanded, the previously specified data is effective. Thus, when the Z axis movement amount does not vary as in the example below, a canned cycle can be repeated only by specifying the movement commands for the X-axis.

However, these data are cleared, if a one-shot G code expect for G04 (dwell) or a G code in the group 01 except for G90, G92, G94 is commanded.

(Example)

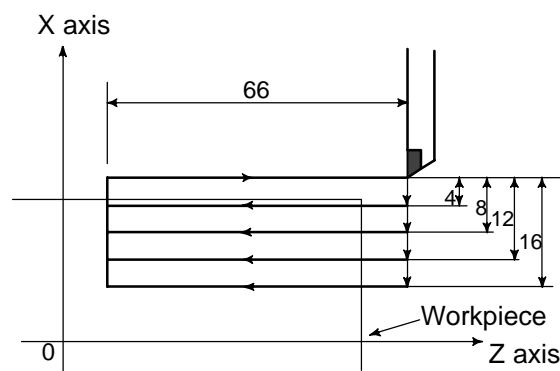

The cycle in the above figure is executed by the following program.

```
N030 G90 U-8.0 W-66.0 F0.4 ;
N031 U-16.0 ;
N032 U-24.0 ;
N033 U-32.0 ;
```

2 The following two applications can be performed.

- (1) If an EOB or zero movement commands are specified for the block following that specified with a canned cycle, the same canned cycle is repeated.
- (2) If the M, S, T function is commanded during the canned cycle mode, both the canned cycle and M, S, or T function can be performed simultaneously. If this is inconvenient, cancel the canned cycle once as in the program examples below (specify G00 or G01) and execute the M, S, or T command. After the execution of M, S, or T terminates, command the canned cycle again.

(Example)

```
N003 T0101 ;
:
:
N010 G90 X20.0 Z10.0 F0.2 ;
N011 G00 T0202 ;
N012 G90 X20.5 Z10.0 ;
```

13.1.4 How to Use Canned Cycles (G90, G92, G94)

An appropriate canned cycle is selected according to the shape of the material and the shape of the product.

- Straight cutting cycle (G90)

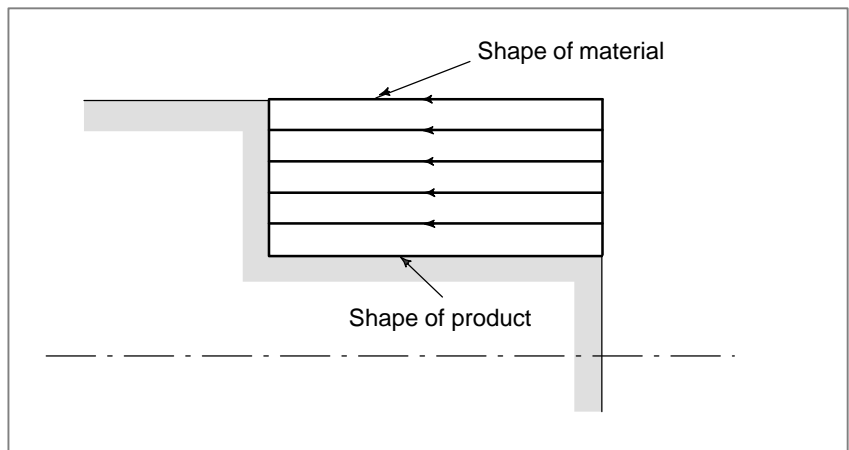

- Taper cutting cycle (G90)

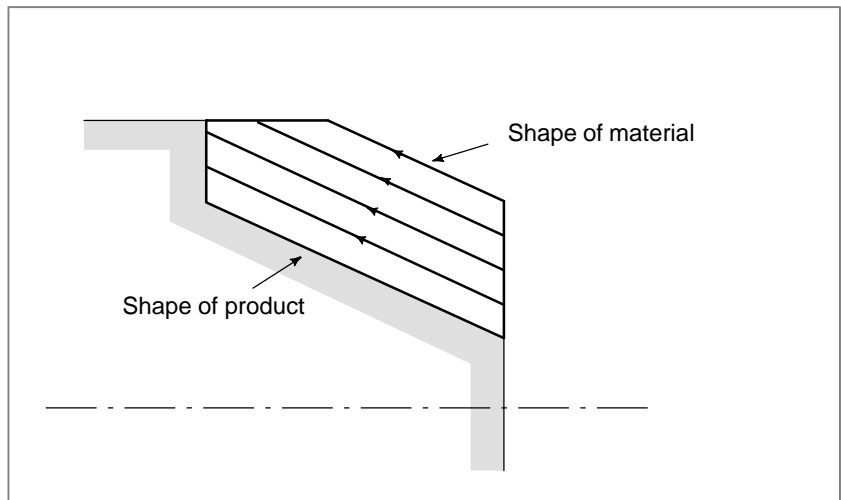

● **Face cutting cycle (G94)**

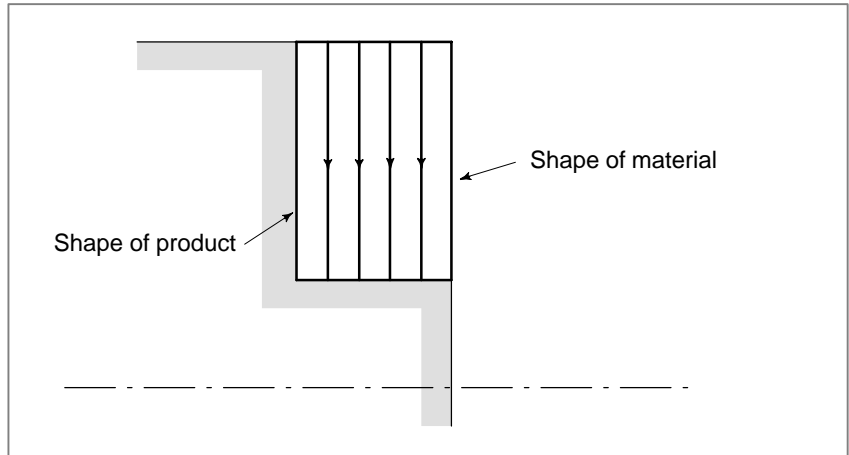

● **Face taper cutting cycle (G94)**

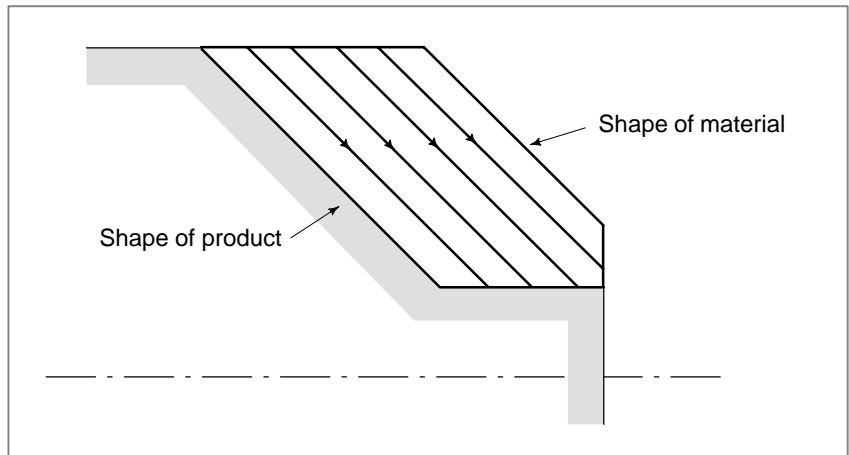

13.2 MULTIPLE REPETITIVE CYCLE (G70-G76)

This option canned cycles to make CNC programming easy. For instance, the data of the finish work shape describes the tool path for rough machining. And also, a canned cycles for the thread cutting is available.

13.2.1 Stock Removal in Turning (G71)

There are two types of stock removals in turning : Type I and II.

- Type I

If a finished shape of A to A' to B is given by a program as in the figure below, the specified area is removed by Δd (depth of cut), with finishing allowance $\Delta u/2$ and Δw left.

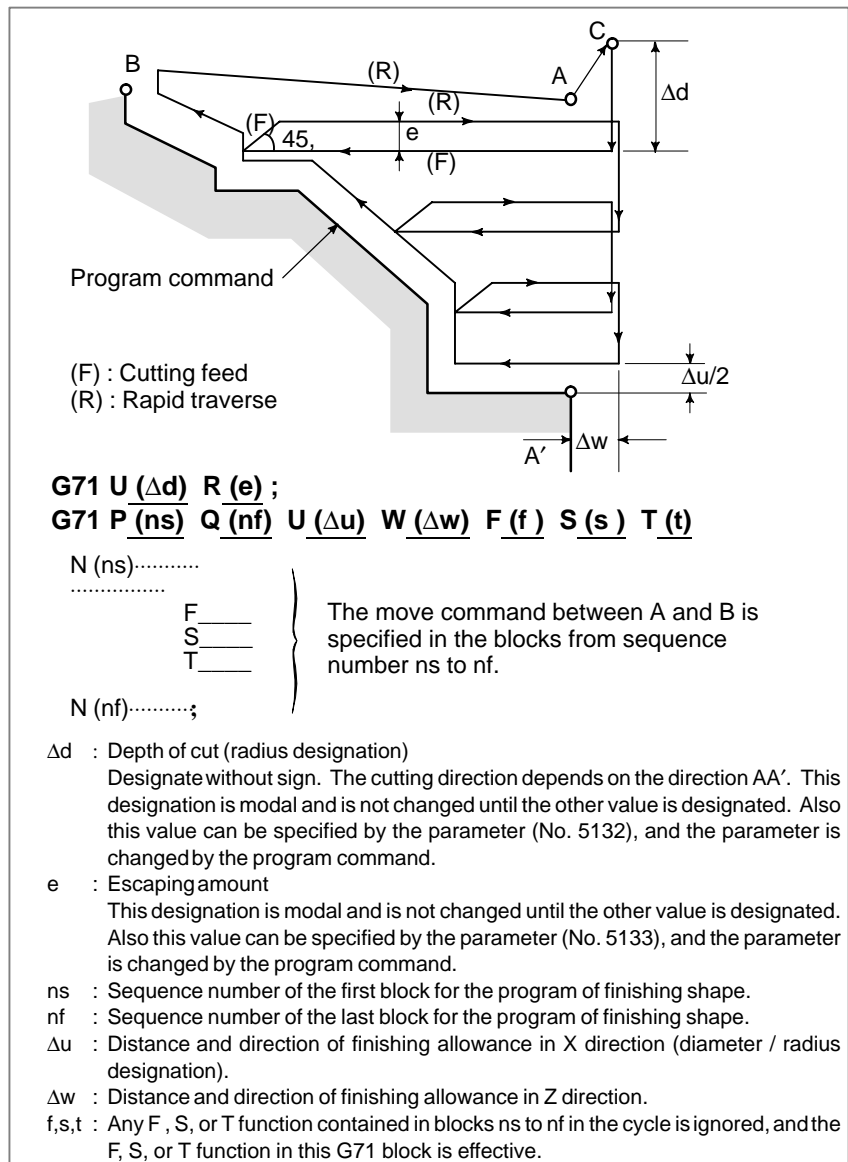

Fig. 13.2.1 (a) Cutting Path in Stock Removal in Turning (Type I)

NOTE

- 1 While both Δd and Δu , are specified by address U, the meanings of them are determined by the presence of addresses P and Q.
- 2 The cycle machining is performed by G71 command with P and Q specification.
F, S, and T functions which are specified in the move command between points A and B are ineffective and those specified in G71 block or the previous block are effective.

When an option of constant surface speed control is selected, G96 or G97 command specified in the move command between points A and B are ineffective, and that specified in G71 block or the previous block is effective.

The following four cutting patterns are considered. All of these cutting cycles are made paralleled to Z axis and the sign of Δu and Δw are as follows:

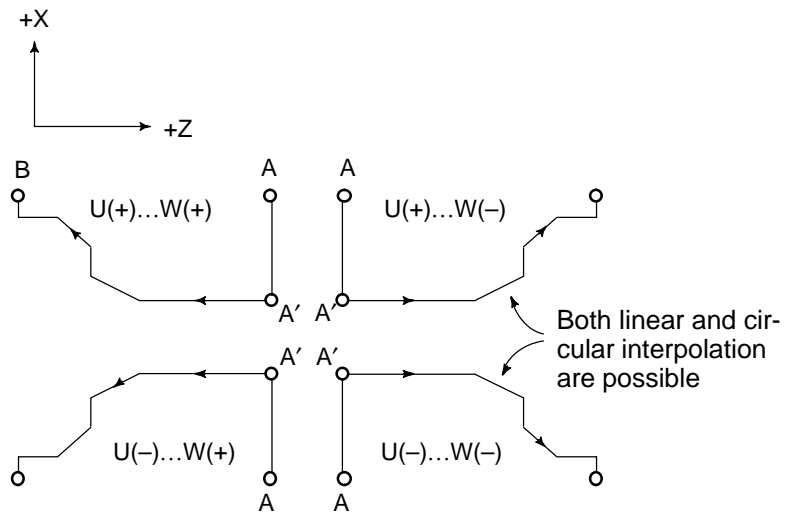

The tool path between A and A' is specified in the block with sequence number "ns" including G00 or G01, and in this block, a move command in the Z axis cannot be specified. The tool path between A' and B must be steadily increasing or decreasing pattern in both X and Z axis. When the tool path between A and A' is programmed by G00/G01, cutting along AA' is performed in G00/G01 mode respectively.

- 3 The subprogram cannot be called from the block between sequence number "ns" and "nf".

• **Type II**

Type II differs from type I in the following : The profile need not show monotone increase or monotone decrease along the X axis, and it may have up to 10 concaves (pockets).

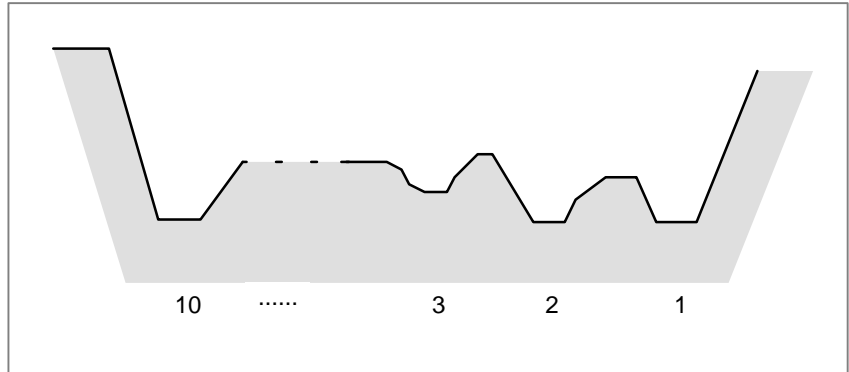

Fig. 13.2.1 (b) Number of Pockets in Stock Removal in Turning (Type II)

Note that, however, the profile must have monotone decrease or increase along the Z axis. The following profile cannot be machined:

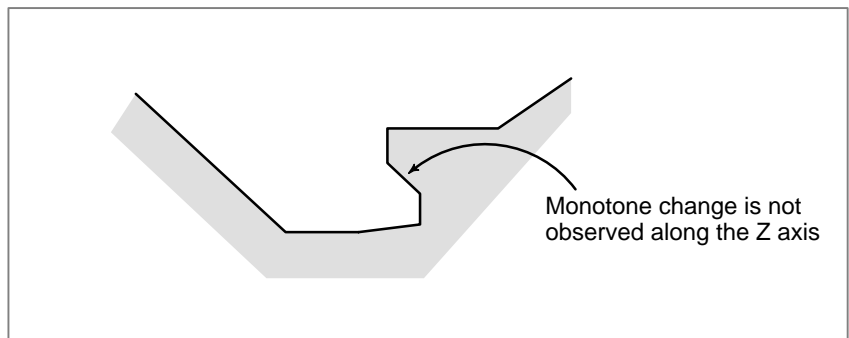

Fig. 13.2.1 (c) Figure Which Cannot Be Machined in Stock Removal in Turning (Type II)

The first cut portion need not be vertical ; any profile is permitted if monotone change is shown along the Z axis.

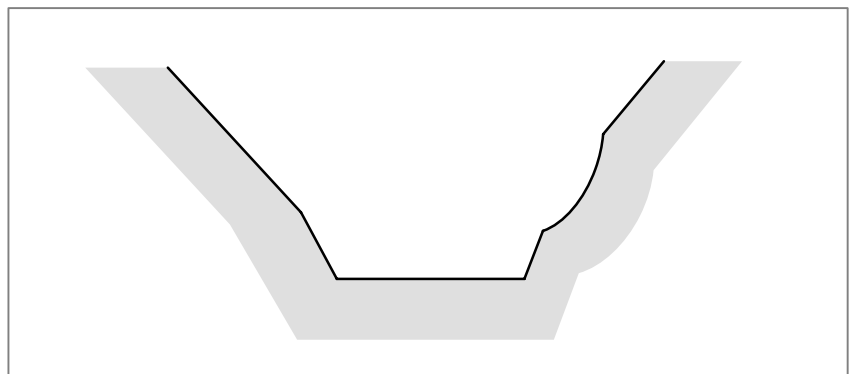

Fig. 13.2.1 (d) Figure Which Can Be Machined (Monotonic change) in Stock Removal in Turning (Type II)

After turning, a clearance is provided by cutting along the workpiece profile.

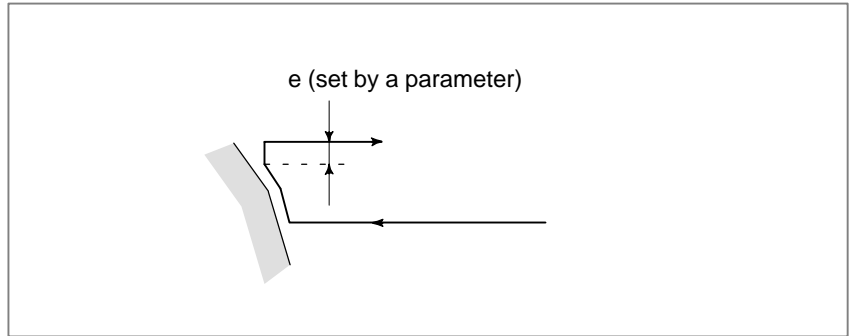

Fig. 13.2.1 (e) Chamfering in Stock Removal in Turning (Type II)

The clearance e (specified in R) to be provided after cutting can also be set in parameter No. 5133.

A sample cutting path is given below:

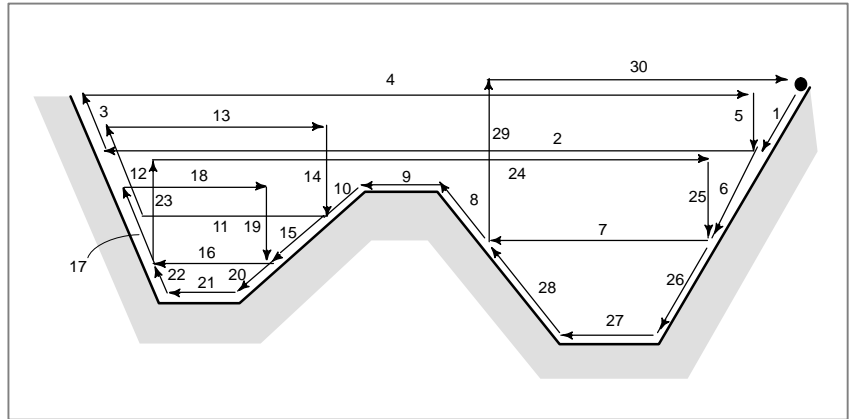

Fig. 13.2.1 (f) Cutting Path in Stock Removal in Facing

The offset of the tool radius is not added to finishing allowances Δu and Δw . In turning, the offset of the tool tip radius is assumed to be zero.

$W=0$ must be specified ; otherwise, the tool tip may cut into one wall side. For the first block of a repetitive portion, two axes X (U) and Z (W) must be specified. When Z motion is not performed, W0 is also specified.

• **Distinction between type I and type II**

When only one axis is specified in the first block of a repetitive portion -- Type I

When two axes are specified in the first block of a repetitive portion -- Type II

When the first block does not include Z motion and type II is to be used, W0 must be specified.

(Example)

TYPE I	TYPE II
G71 V10.0 R5.0 ;	G71 V10.0 R5.0 ;
G71 P100 Q200.....;	G71 P100 Q200.....;
N100X (U)___;	N100X (U)___ Z(W)___;
:	:
:	:
N200.....;	N200.....;

13.2.2 Stock Removal in Facing (G72)

As shown in the figure below, this cycle is the same as G71 except that cutting is made by a operation parallel to X axis.

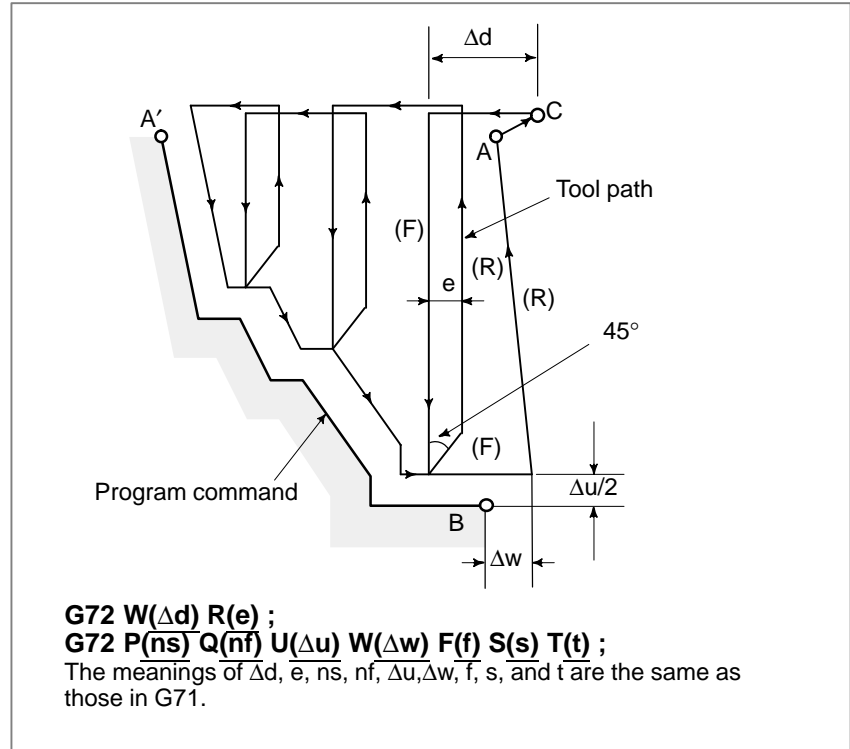

Fig. 13.2.2 (a) Cutting Path in Stock Removal in Facing

• **Signs of specified numbers**

The following four cutting patterns are considered. All of these cutting cycles are made parallel to X axis and the sign of Δu and Δw are as follows:

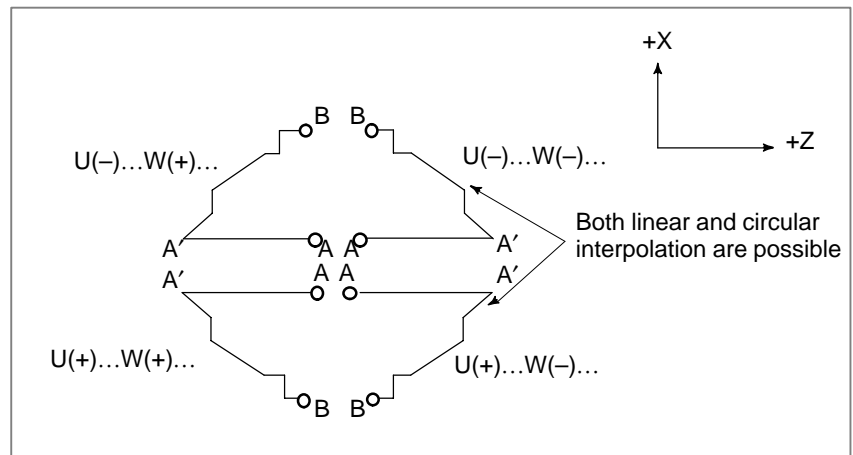
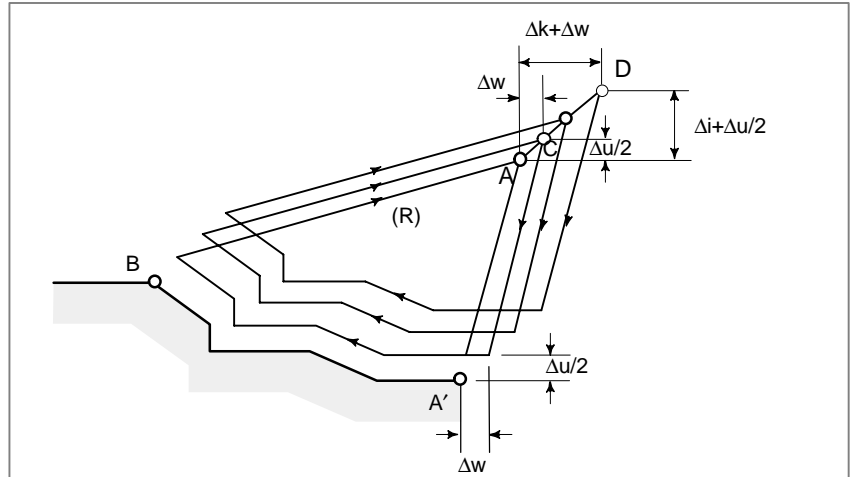

Fig. 13.2.2 (b) Signs of Numbers Specified with U and W in Stock Removal in Facing

The tool path between A and A' is specified in the block with sequence number "ns" including G00 or G01, and in this block, a move command in the X axis cannot be specified. The tool path between A' and B must be steadily increasing and decreasing pattern in both X and Z axes. Whether the cutting along AA' is G00 or G01 mode is determined by the command between A and A', as described in item 13.2.1.

13.2.3 Pattern Repeating (G73)

This function permits cutting a fixed pattern repeatedly, with a pattern being displaced bit by bit. By this cutting cycle, it is possible to efficiently cut work whose rough shape has already been made by a rough machining, forging or casting method, etc.



The pattern commanded in the program should be as follows.

A→A'→B

G73 U (Δi) W (Δk) R (d) ;

G73 P (ns) Q (nf) U (Δu) W (Δw) F (f) S (s) T (t) ;

N (ns).....

.....

F _____
S _____
T _____

N (nf).....;

The move command between A and B is specified in the blocks from sequence number ns to nf.

- Δi : Distance and direction of relief in the X axis direction (Radius designation). This designation is modal and is not changed until the other value is designated. Also this value can be specified by the parameter No. 5135, and the parameter is changed by the program command.
- Δk : Distance and direction of relief in the Z axis direction. This designation is modal and is not changed until the other value is designated. Also this value can be specified by the parameter No. 5136, and the parameter is changed by the program command.
- d : The number of division
This value is the same as the repetitive count for rough cutting. This designation is modal and is not changed until the other value is designated. Also, this value can be specified by the parameter No. 5137, and the parameter is changed by the program command.
- ns : Sequence number of the first block for the program of finishing shape.
- nf : Sequence number of the last block for the program of finishing shape.
- Δu : Distance and direction of finishing allowance in X direction (diameter/radius designation)
- Δw : Distance and direction of finishing allowance in Z direction
- f,s,t : Any F, S, and T function contained in the blocks between sequence number "ns" and "nf" are ignored, and the F, S, and T functions in this G73 block are effective.

Fig. 13.2.3 Cutting path in Pattern Repeating

NOTE

- 1 While the values Δi and Δk , or Δu and Δw are specified by address U and W respectively, the meanings of them are determined by the presence of addresses P and Q in G73 block. When P and Q are not specified in a same block, addresses U and W indicates Δi and Δk respectively. When P and Q are specified in a same block, addresses U and W indicates Δu and Δw respectively.
- 2 The cycle machining is performed by G73 command with P and Q specification.
The four cutting patterns are considered. Take care of the sign of Δu , Δw , Δk , and Δi .
When the machining cycle is terminated, the tool returns to point A.

13.2.4 Finishing Cycle (G70)

After rough cutting by G71, G72 or G73, the following command permits finishing.

Format

G70P (ns) Q (nf) ;

(ns) : Sequence number of the first block for the program of finishing shape.

(nf) : Sequence number of the last block for the program of finishing shape.

NOTE

- 1 F, S, and T functions specified in the block G71, G72, G73 are not effective but those specified between sequence numbers "ns" and "nf" are effective in G70.
- 2 When the cycle machining by G70 is terminated, the tool is returned to the start point and the next block is read.
- 3 In blocks between "ns" and "nf" referred in G70 through G73, the subprogram cannot be called.

Examples

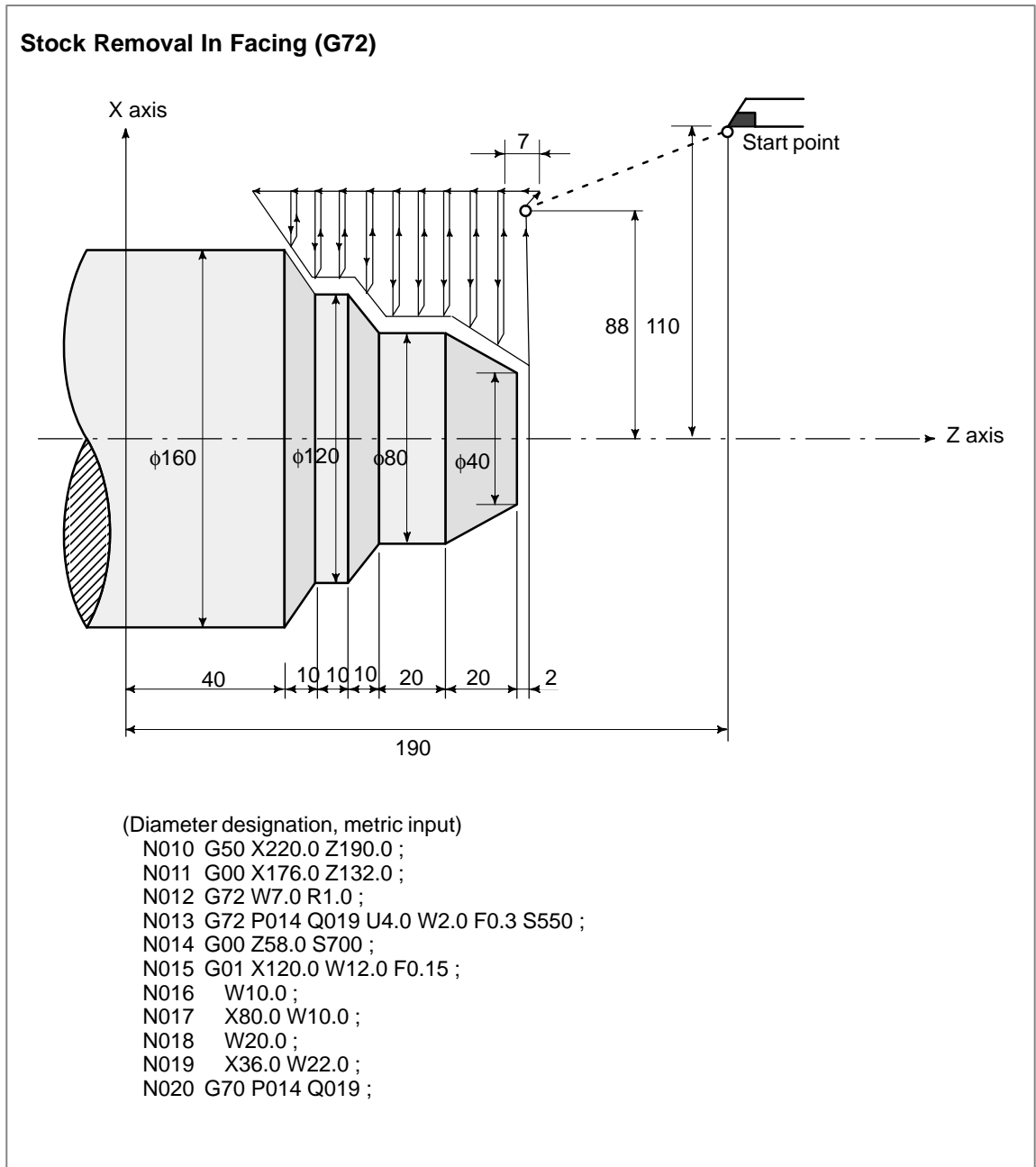

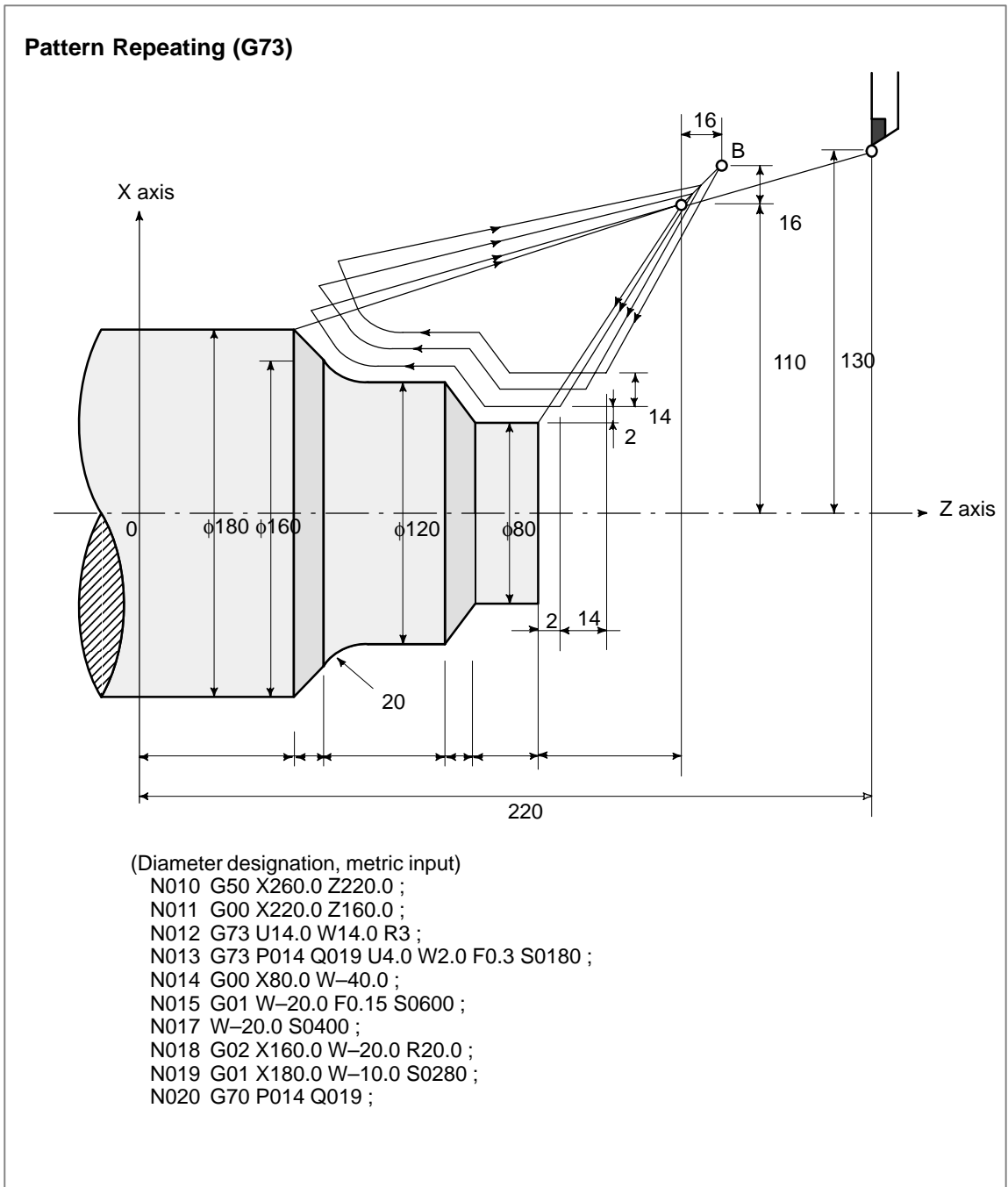

13.2.5 End Face Peck Drilling Cycle (G74)

The following program generates the cutting path shown in Fig. 13.2.5. Chip breaking is possible in this cycle as shown below. If X (U) and P are omitted, operation only in the Z axis results, to be used for drilling.

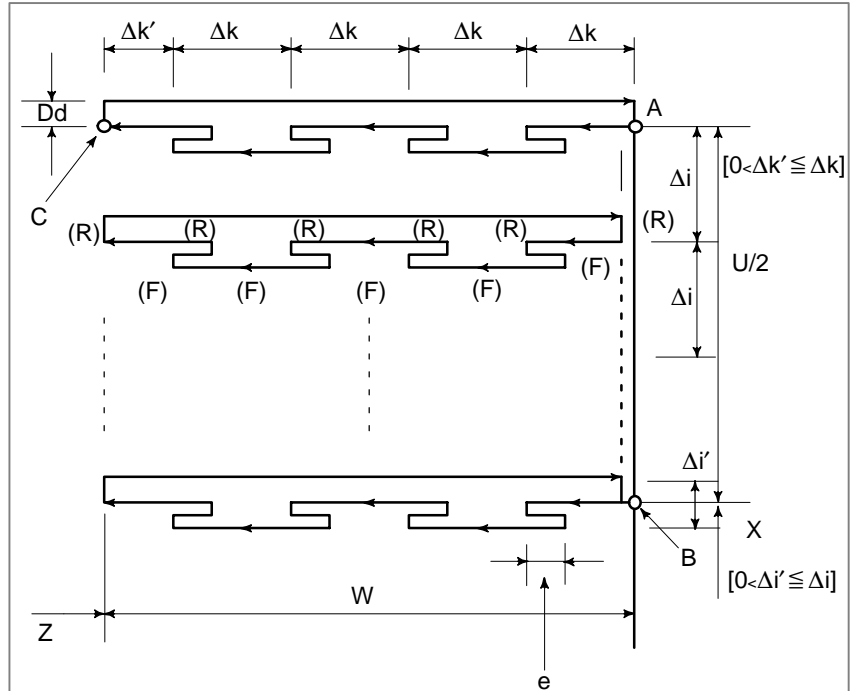

G74R (e) ;

G74X(U)_ Z(W)_ P(Δi) Q(Δk) R(Δd) F (f) ;

e : Return amount

This designation is modal and is not changed until the other value is designated. Also this value can be specified by the parameter No. 5139, and the parameter is changed by the program command.

X : X component of point B

U : Incremental amount from A to B

Z : Z component of point C

W : Increment amount from A to C

Δi : Movement amount in X direction (without sign)

Δk : Depth of cut in Z direction (without sign)

Δd : Relief amount of the tool at the cutting bottom. The sign of Δd is always plus (+). However, if address X (U) and Δi are omitted, the relief direction can be specified by the desired sign.

f : Feed rate

Fig. 13.2.5 Cutting Path in End Face Peck Drilling Cycle

NOTE

- 1 While both e and Δd are specified by address R, the meanings of them are determined by the present of address X (U). When X(U) is specified, Δd is used.
- 2 The cycle machining is performed by G74 command with X (U) specification.

13.2.6 Outer Diameter / Internal Diameter Drilling Cycle (G75)

The following program generates the cutting path shown in Fig. 13.2.6. This is equivalent to G74 except that X is replaced by Z. Chip breaking is possible in this cycle, and grooving in X axis and peck drilling in X axis (in this case, Z, W, and Q are omitted) are possible.

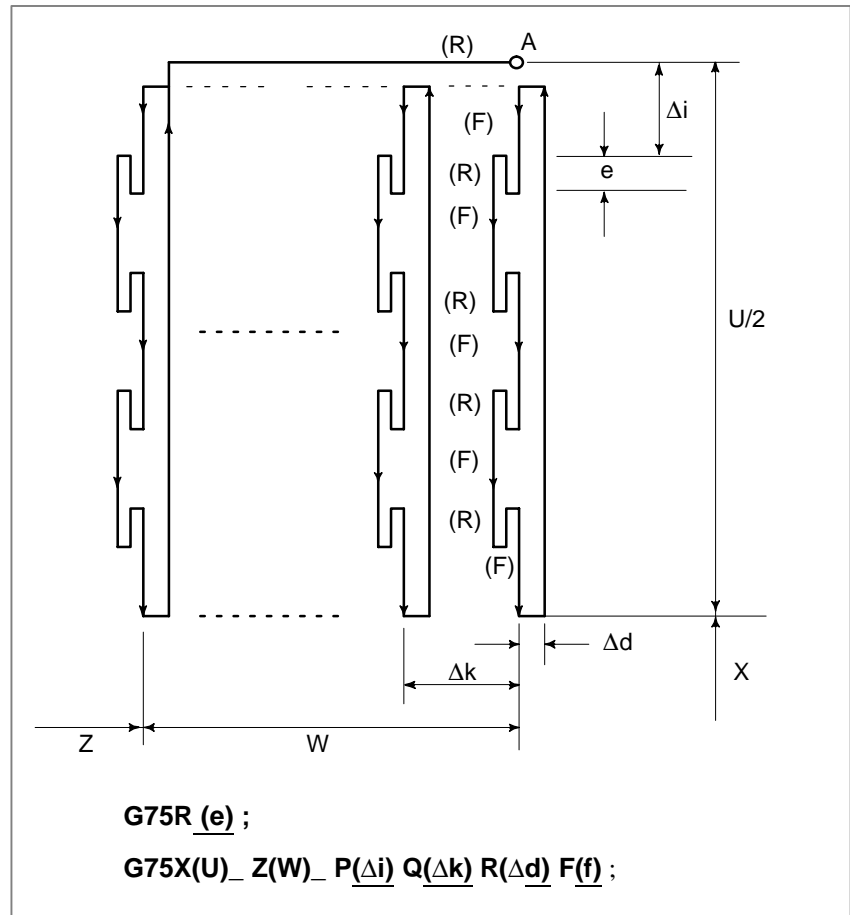

Fig. 13.2.6
Cutting Path in Outer Diameter / Internal Diameter Drilling Cycle

Both G74 and G75 are used for grooving and drilling, and permit the tool to relief automatically. Four symmetrical patterns are considered, respectively.

13.2.7 Multiple Thread Cutting Cycle (G76)

The thread cutting cycle as shown in Fig.13.2.7 is programmed by the G76 command.

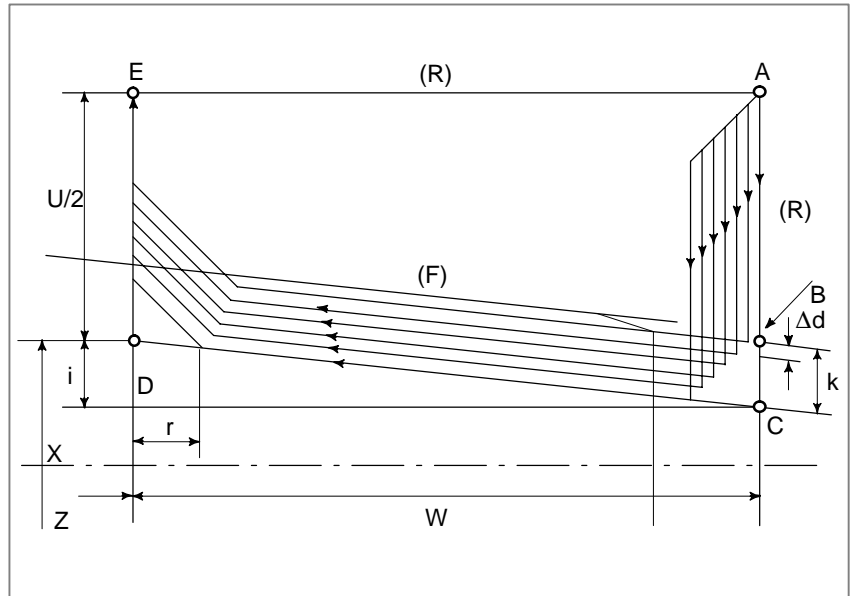

Fig. 13.2.7 Cutting Path in Multiple thread cutting cycle

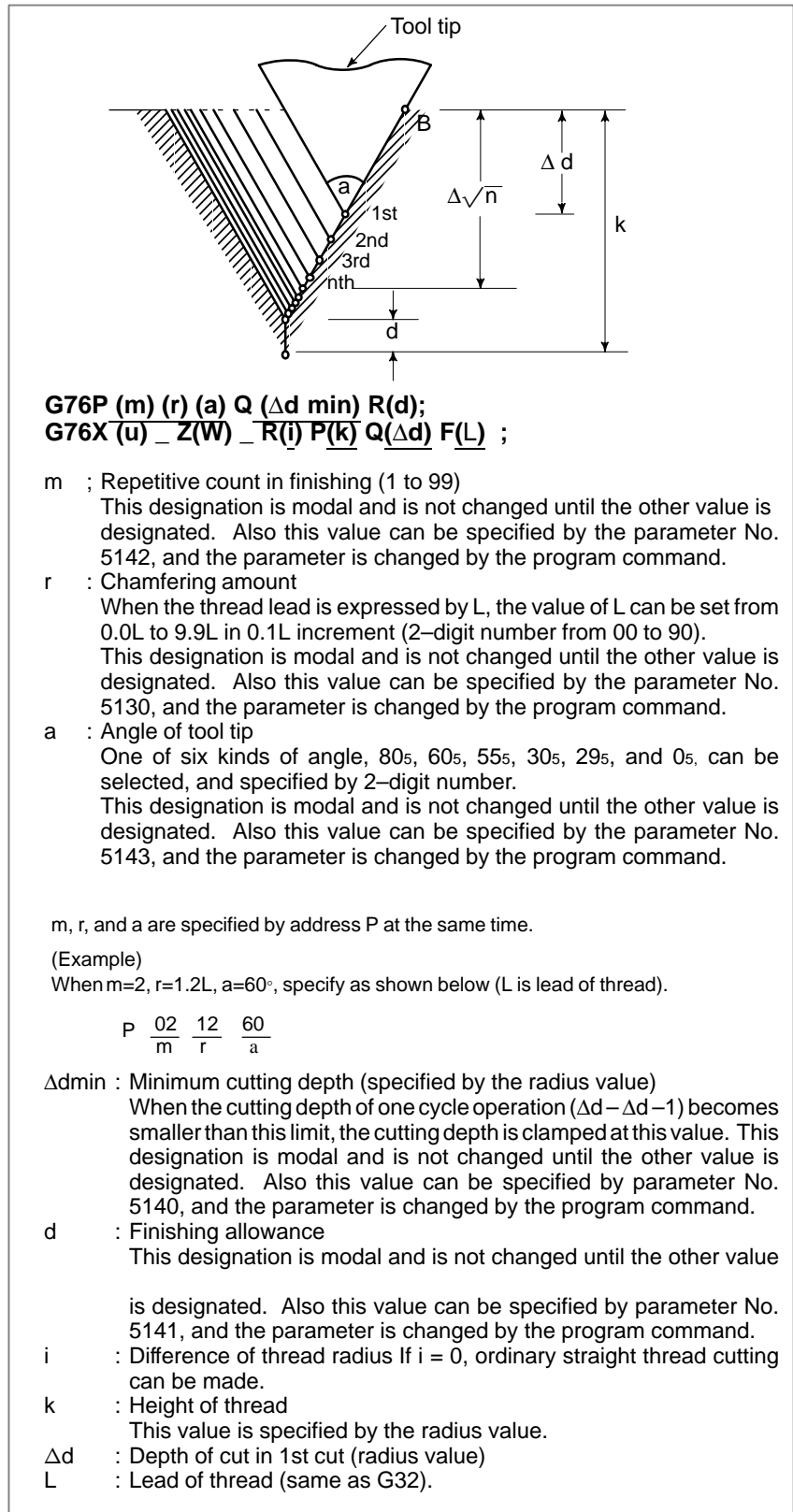

Fig. 13.2.7 (b) Detail of cutting

- **Thread cutting cycle retract**

When feed hold is applied during threading in the multiple thread cutting cycle (G76), the tool quickly retracts in the same way as in chamfering performed at the end of the thread cutting cycle. The tool goes back to the start point of the cycle. When cycle start is triggered, the multiple thread cutting cycle resumes.

Without this retraction function, when feed hold is applied during threading, the tool goes back to the start point of the cycle after threading is completed.

See notes in 13.1.2.

NOTE

- 1 The meanings of the data specified by address P, Q, and R determined by the presence of X (U) and X (W).
- 2 The cycle machining is performed by G76 command with X (U) and Z (W) specification.
By using this cycle, one edge cutting is performed and the load on the tool tip is reduced.
Making the cutting depth Δd for the first path, and Δdn for the nth path, cutting amount per one cycle is held constant. Four symmetrical patterns are considered corresponding to the sign of each address.
The internal thread cutting is available. In the above figure, the feed rate between C and D is specified by address F, and in the other path, at rapid traverse. The sign of incremental dimensions for the above figure is as follows:
U, W : minus (determined by the direction of the tool path AC and CD.)
R : minus (determined by the direction of the tool path AC.)
P : plus (always)
Q : plus (always)
- 3 Notes on thread cutting are the same as those on G32 thread cutting and G92 thread cutting cycle.
- 4 The designation of chamfering is also effective for G92 thread cutting cycle.
- 5 The tool returns to the cycle start point at that time (cutting depth Δdn) as soon as the feed hold status is entered during thread cutting when the "Thread Cutting Cycle retract" option is used.

Examples

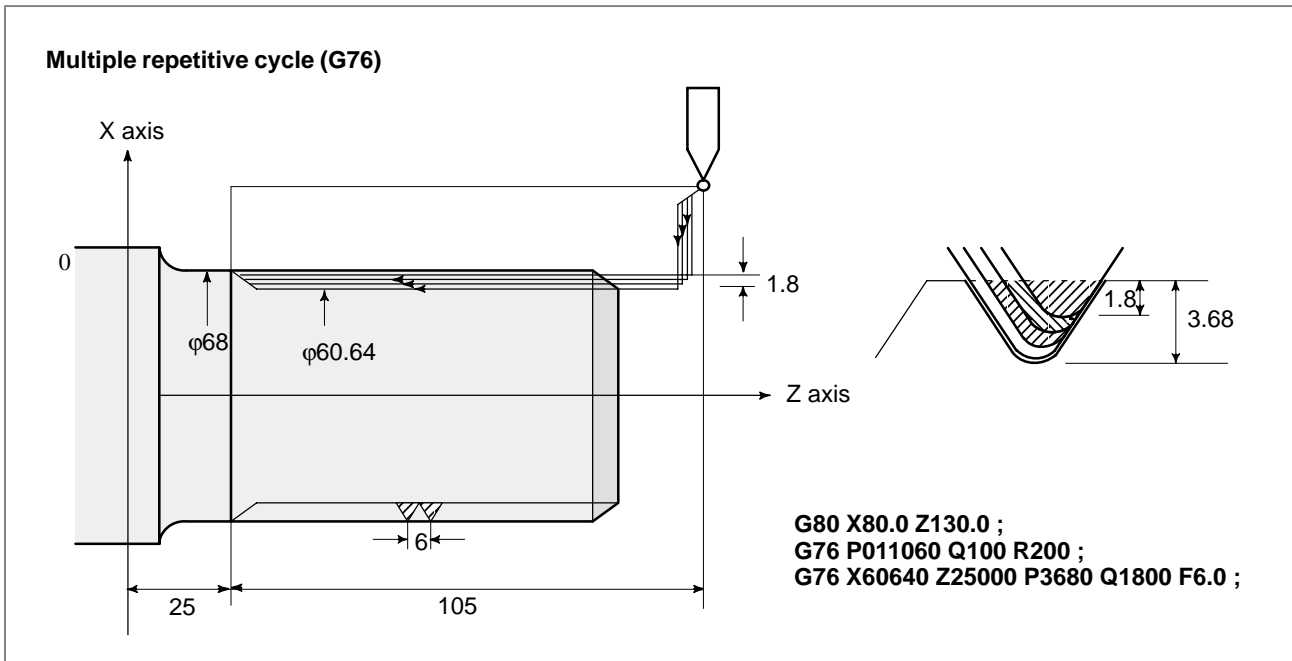

• **Staggered thread cutting**

Specifying P2 can perform staggered thread cutting with a constant depth of cut.

Example: G76 X60640 Z25000 K3680 D1800 F6.0 A60 P2;

For staggered thread cutting, always use the FS15 tape format (see Section 18.5).

If the depth of cut in one cycle is less than d_{min} (specified in parameter No. 5140), the depth of cut is clamped at Δd_{min} .

NOTE
Multiple repetitive cycle II is required.

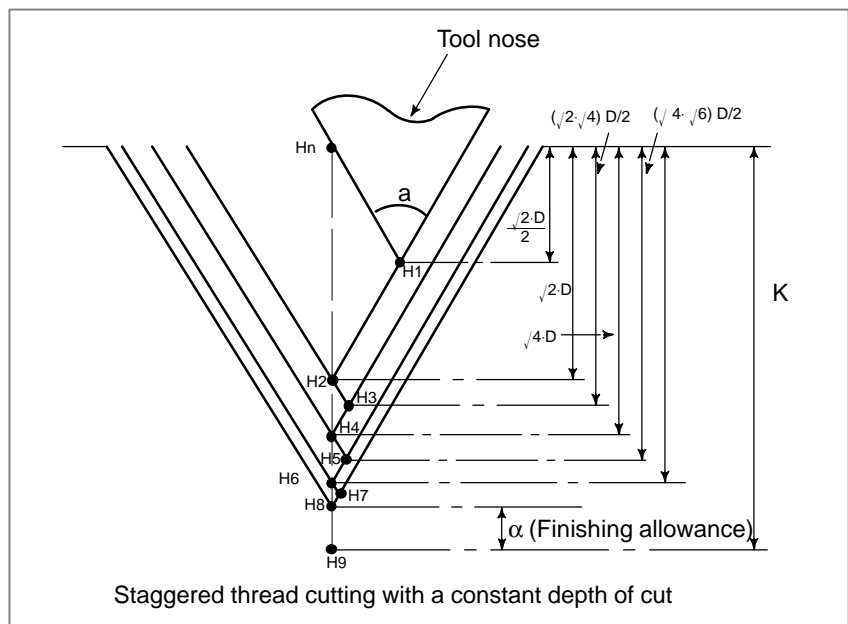

13.2.8 Notes on Multiple Repetitive Cycle (G70–G76)

1. In the blocks where the multiple repetitive cycle are commanded, the addresses P, Q, X, Z, U, W, and R should be specified correctly for each block.
2. In the block which is specified by address P of G71, G72 or G73, G00 or G01 group should be commanded. If it is not commanded, P/S alarm No. 65 is generated.
3. In MDI mode, G70, G71, G72, or G73 cannot be commanded. If it is commanded, P/S alarm No. 67 is generated. G74, G75, and G76 can be commanded in MDI mode.
4. In the blocks in which G70, G71, G72, or G73 are commanded and between the sequence number specified by P and Q, M98 (subprogram call) and M99 (subprogram end) cannot be commanded.
5. In the blocks between the sequence number specified by P and Q, the following commands cannot be specified.
 - One shot G code except for G04 (dwell)
 - 01 group G code except for G00, G01, G02, and G03
 - 06 group G code
 - M98 / M99
6. While a multiple repetitive cycle (G70AG76) is being executed, it is possible to stop the cycle and to perform manual operation. But, when the cycle operation is restarted, the tool should be returned to the position where the cycle operation is stopped.
If the cycle operation is restarted without returning to the stop position, the movement in manual operation is added to the absolute value, and the tool path is shifted by the movement amount in manual operation.
7. When G70, G71, G72, or G73 is executed, the sequence number specified by address P and Q should not be specified twice or more in the same program.
8. The blocks between the sequence number specified by P and Q on the multiple repetitive cycle must not be programmed by using “Direct Drawing Dimensions Programming” or “Chamfering and Corner R”.
9. G74, G75, and G76 also do not support the input of a decimal point for P or Q. The least input increments are used as the units in which the amount of travel and depth of cut are specified.
10. When #1 = 2500 is executed using a custom macro, 2500.000 is assigned to #1. In such a case, P#1 is equivalent to P2500.
11. Tool nose radius compensation cannot be applied to G71, G72, G73, G74, G75, G76, or G78.
12. The multiple repetitive cycle cannot be executing during DNC operation.
13. Interruption type custom macro cannot be executed during executing the multiple repetitive cycle.
14. The multiple repetitive cycle cannot be executing during Advanced Preview Control mode.

13.3 CANNED CYCLE FOR DRILLING (G80–G89)

The canned cycle for drilling simplifies the program normally by directing the machining operation commanded with a few blocks, using one block including G code.

This canned cycle conforms to JIS B 6314.

Following is the canned cycle table.

Table 13.3 (a) Canned Cycles

G code	Drilling axis	Hole machining operation (- direction)	Operation in the bottom hole position	Retraction operation (+ direction)	Applications
G80	—	—	—	—	Cancel
G83	Z axis	Cutting feed / intermittent	Dwell	Rapid traverse	Front drilling cycle
G84	Z axis	Cutting feed	Dwell→spindle CCW	Cutting feed	Front tapping cycle
G85	Z axis	Cutting feed	—	Cutting feed	Front boring cycle
G87	X axis	Cutting feed / intermittent	Dwell	Rapid traverse	Side drilling cycle
G88	X axis	Cutting feed	Dwell→Spindle CCW	Cutting feed	Side tapping cycle
G89	X axis	Cutting feed	Dwell	Cutting feed	Side boring cycle

In general, the drilling cycle consists of the following six operation sequences.

- Operation 1 Positioning of X (Z) and C axis
- Operation 2 Rapid traverse up to point R level
- Operation 3 Hole machining
- Operation 4 Operation at the bottom of a hole
- Operation 5 Retraction to point R level
- Operation 6 Rapid traverse up to the initial point

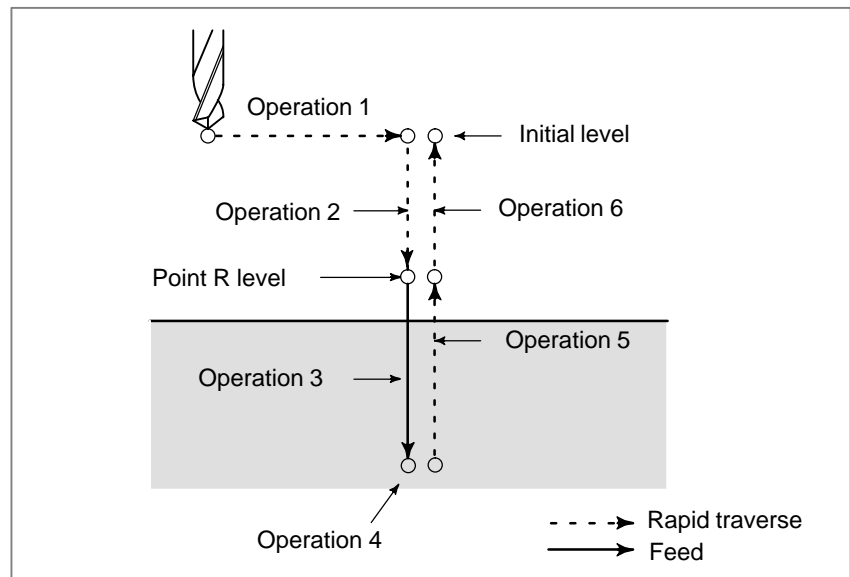

Fig. 13.3 Drilling Cycle Operation Sequence

Explanations

● **Positioning axis and drilling axis**

A drilling G code specifies positioning axes and a drilling axis as shown below. The C-axis and X- or Z-axis are used as positioning axes. The X- or Z-axis, which is not used as a positioning axis, is used as a drilling axis.

Although canned cycles include tapping and boring cycles as well as drilling cycles, in this chapter, only the term drilling will be used to refer to operations implemented with canned cycles.

Table13.3 (b) Positioning axis and drilling axis

G code	Positioning plane	Drilling axis
G83, G84, G85	X axis, C axis	Z axis
G87, G88, G89	Z axis, C axis	X axis

G83 and G87, G84 and G88, and G85 and G89 have the same function respectively except for axes specified as positioning axes and a drilling axis.

● **Drilling mode**

G83AG85 / G87A89 are modal G codes and remain in effect until canceled. When in effect, the current state is the drilling mode.

Once drilling data is specified in the drilling mode, the data is retained until modified or canceled.

Specify all necessary drilling data at the beginning of canned cycles; when canned cycles are being performed, specify data modifications only.

● **Return point level G98/G99**

In G code system A, the tool returns to the initial level from the bottom of a hole. In G code system B or C, specifying G98 returns the tool to the initial level from the bottom of a hole and specifying G99 returns the tool to the point-R level from the bottom of a hole.

The following illustrates how the tool moves when G98 or G99 is specified. Generally, G99 is used for the first drilling operation and G98 is used for the last drilling operation.

The initial level does not change even when drilling is performed in the G99 mode.

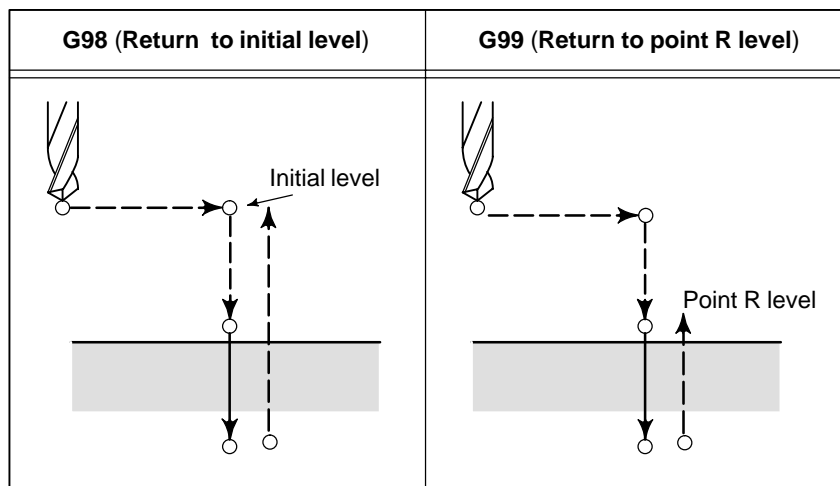

- **Number of repeats**

To repeat drilling for equally-spaced holes, specify the number of repeats in $K_{_}$.

K is effective only within the block where it is specified.

Specify the first hole position in incremental mode.

If it is specified in absolute mode, drilling is repeated at the same position.

Number of repeats K	The maximum command value = 9999
-----------------------	----------------------------------

When $K0$ is specified with parameter $K0E$ (parameter No. 5102 #4) set to 0, drilling is performed once.

When $K0$ is specified with parameter $K0E$ (parameter No. 5102 #4) set to 1, drilling data is just stored without drilling being performed.

- **M code used for C-axis clamp/unclamp**

When an M code specified in parameter No. 5110 for C-axis clamp / unclamp is coded in a program, the CNC issues the M code for C-axis clamp after the tool is positioned and before the tool is fed in rapid traverse to the point-R level. The CNC also issues the M code for C-axis unclamp (the M code for C-axis clamp +1) after the tool retracts to the point-R level. The tool dwells for the time specified in parameter No. 5111.

- **Cancel**

To cancel a canned cycle, use G80 or a group 01 G code.

Group 01 G codes

G00 : Positioning (rapid traverse)



G01 : Linear interpolation

G02 : Circular interpolation (CW)

G03 : Circular interpolation (CCW)

- **Symbols in figures**

Subsequent sections explain the individual canned cycles. Figures in these explanations use the following symbols:

	Positioning (rapid traverse G00)
	Cutting feed (linear interpolation G01)
	Manual feed
P1	Dwell specified in the program
P1	Dwell specified in parameter No.5111
$M\alpha$	Issuing the M code for C-axis clamp (The value of α is specified with parameter No. 5110.)
$M(\alpha+1)$	Issuing the M code for C-axis unclamp

CAUTION

- In each canned cycle,
R_ (distance between the initial level and point R) is always handled as a radius.
Z_ or X_ (distance between point R and the bottom of the hole) is, however, handled either as a diameter or radius, depending on the specification.
- For the B or C G-code system, G90 or G91 can be used to select an incremental or absolute command for hole position data (X, C or Z, C), the distance from point R to the bottom of the hole (Z or X), and the distance from the initial level to the point R level (R).

13.3.1 Front Drilling Cycle (G83) / Side Drilling Cycle (G87)

The peck drilling cycle or high-speed peck drilling cycle is used depending on the setting in RTR, bit 2 of parameter No. 5101. If depth of cut for each drilling is not specified, the normal drilling cycle is used.

- High-speed peck drilling cycle (G83, G87) (parameter RTR (No. 5101#2) =0)

This cycle performs high-speed peck drilling. The drill repeats the cycle of drilling at the cutting feedrate and retracting the specified retraction distance intermittently to the bottom of a hole. The drill draws cutting chips out of the hole when it retracts.

Format

<p>G83 X(U)_ C(H)_ Z(W)_ R_ Q_ P_ F_ K_ M_ ; or G87 Z(W)_ C(H)_ X(U)_ R_ Q_ P_ F_ K_ M_ ;</p> <p>X_ C_ or Z_ C_ : Hole position data Z_ or X_ : The distance from point R to the bottom of the hole R_ : The distance from the initial level to point R level Q_ : Depth of cut for each cutting feed P_ : Dwell time at the bottom of a hole F_ : Cutting feedrate K_ : Number of repeats (When it is needed) M_ : M code for C-axis clamp (When it is needed.)</p>	
G83 or G87 (G98 mode)	G83 or G87 (G99 mode)

- Mα : M code for C-axis clamp
- M(α+1) : M code for C-axis unclamp
- P1 : Dwell specified in the program
- P2 : Dwell specified in parameter No. 5111
- d : Retraction distance specified in parameter No. 5114

- **Peck drilling cycle (G83, G87) (parameter No. 5101#2 =1)**

Format

<p>G83 X(U)_ C(H)_ Z(W)_ R_ Q_ P_ F_ K_ M_ ; or G87 Z(W)_ C(H)_ X(U)_ R_ Q_ P_ F_ K_ M_ ;</p> <p>X_ C_ or Z_ C_ : Hole position data Z_ or X_ : The distance from point R to the bottom of the hole R_ : The distance from the initial level to point R level Q_ : Depth of cut for each cutting feed P_ : Dwell time at the bottom of a hole F_ : Cutting feedrate K_ : Number of repeats (When it is needed.) M_ : M code for C-axis clamp (When it is needed.)</p>	
G83 or G87 (G98 mode)	G83 or G87 (G99 mode)

- Mα : M code for C-axis clamp
- M(α+1) : M code for C-axis unclamp
- P1 : Dwell specified in the program
- P2 : Dwell specified in parameter No. 5111
- d : Retraction distance specified in parameter No. 5114

Examples

<p>M51 ; M3 S2000 ; G00 X50.0 C0.0 ;</p> <p>G83 Z-40.0 R-5.0 Q5000 F5.0 M31 ; C90.0 Q5000 M31 ; C180.0 Q5000 M31 ; C270.0 Q5000 M31 ; G80 M05 ;</p> <p>M50 ;</p>	<p>Setting C-axis index mode ON Rotating the drill Positioning the drill along the X- and C-axes</p> <p>Drilling hole 1 Drilling hole 2 Drilling hole 3 Drilling hole 4 Canceling the drilling cycle and stopping drill rotation Setting C-axis index mode off</p>
---	--

NOTE

If the depth of cut for each cutting feed (Q) is not commanded, normal drilling is performed. (See the description of the drilling cycle.)

• **Drilling cycle (G83 or G87)**

If depth of cut is not specified for each drilling, the normal drilling cycle is used. The tool is then retracted from the bottom of the hole in rapid traverse.

Format

G83 X(U)_ C(H)_ Z(W)_ R_ P_ F_ K_ M_ ;
or
G87 Z(W)_ C(H)_ X(U)_ R_ P_ F_ K_ M_ ;

- X_ C_ or Z_ C_ : Hole position data
- Z_ or X_ : The distance from point R to the bottom of the hole
- R_ : The distance from the initial level to point R level
- P_ : Dwell time at the bottom of a hole
- F_ : Cutting feedrate
- K_ : Number of repeats (When it is needed.)
- M_ : M code for C-axis clamp (When it is needed.)

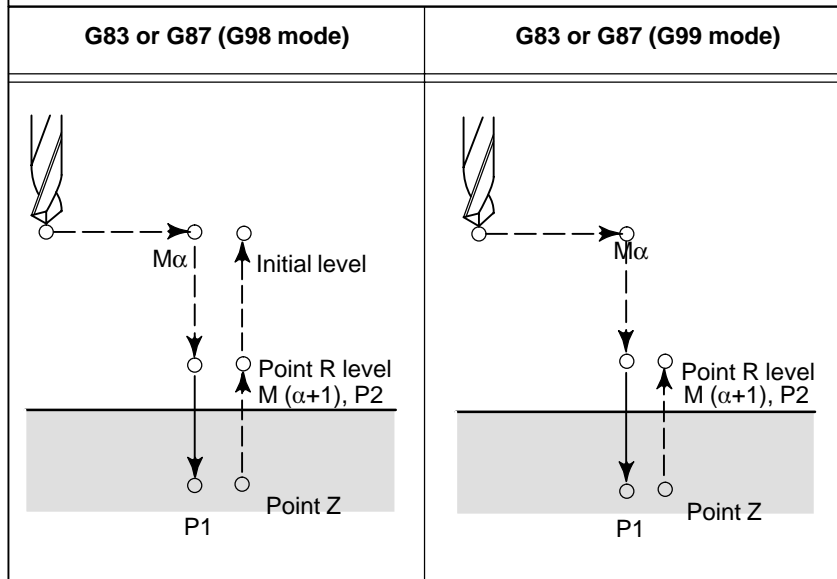

- M α : M code for C-axis clamp
- M(α +1) : M code for C-axis unclamp
- P1 : Dwell specified in the program
- P2 : Dwell specified in parameter No. 5111

Examples

M51 ;	Setting C-axis index mode ON
M3 S2000 ;	Rotating the drill
G00 X50.0 C0.0 ;	Positioning the drill along the X- and C-axes
G83 Z-40.0 R-5.0 P500 F5.0 M31 ;	Drilling hole 1
C90.0 M31 ;	Drilling hole 2
C180.0 M31 ;	Drilling hole 3
C270.0 M31 ;	Drilling hole 4
G80 M05 ;	Canceling the drilling cycle and stopping drill rotation
M50 ;	Setting C-axis index mode off

**13.3.2
Front Tapping Cycle (G84) / Side Tapping Cycle (G88)**

Format

This cycle performs tapping. In this tapping cycle, when the bottom of the hole has been reached, the spindle is rotated in the reverse direction.

<p>G84 X(U)_ C(H)_ Z(W)_ R_ P_ F_ K_ M_ ; or G88 Z(W)_ C(H)_ X(U)_ R_ P_ F_ K_ M_ ;</p> <p>X_ C_ or Z_ C_ : Hole position data Z_ or X_ : The distance from point R to the bottom of the hole R_ : The distance from the initial level to point R level P_ : Dwell time at the bottom of a hole F_ : Cutting feedrate K_ : Number of repeats (When it is needed.) M_ : M code for C-axis clamp (when it is needed.)</p>	
G84 or G88 (G98 mode)	G84 or G88 (G99 mode)

Explanations

Tapping is performed by rotating the spindle clockwise. When the bottom of the hole has been reached, the spindle is rotated in the reverse direction for retraction. This operation creates threads. Feedrate overrides are ignored during tapping. A feed hold does not stop the machine until the return operation is completed.

NOTE

Bit 6 (M5T) of parameter No. 5101 specifies whether the spindle stop command (M05) is issued before the direction in which the spindle rotates is specified with M03 or M04. For details, refer to the operator's manual created by the machine tool builder.

Examples

M51 ;	Setting C-axis index mode ON
M3 S2000 ;	Rotating the drill
G00 X50.0 C0.0 ;	Positioning the drill along the X- and C- axes
G83 Z-40.0 R-5.0 P500 F5.0 M31 ;	Drilling hole 1
C90.0 M31 ;	Drilling hole 2
C180.0 M31 ;	Drilling hole 3
C270.0 M31 ;	Drilling hole 4
G80 M05 ;	Canceling the drilling cycle and stopping drill rotation
M50 ;	Setting C-axis index mode off

13.3.3 Front Boring Cycle (G85) / Side Boring Cycle (G89)

This cycle is used to bore a hole.

Format

<p>G85 X(U)_ C(H)_ Z(W)_ R_ P_ F_ K_ M_ ; or G89 Z(W)_ C(H)_ X(U)_ R_ P_ F_ K_ M_ ;</p> <p>X_ C_ or Z_ C_ : Hole position data Z_ or X_ : The distance from point R to the bottom of the hole R_ : The distance from the initial level to point R level P_ : Dwell time at the bottom of a hole F_ : Cutting feedrate K_ : Number of repeats (When it is needed.) M_ : M code for C-axis clamp (When it is needed.)</p>	
G85 or G89 (G98 mode)	G85 or G89 (G99 mode)

Explanations

After positioning, rapid traverse is performed to point R.
 Drilling is performed from point R to point Z.
 After the tool reaches point Z, it returns to point R at a feedrate twice the cutting feedrate.

Examples

M5 1 ;	Setting C-axis index mode ON
M3 S2000 ;	Rotating the drill
G00 X50.0 C0.0 ;	Positioning the drill along the X- and C-axes
G83 Z-40.0 R-5.0 P500 F5.0 M31 ;	Drilling hole 1
C90.0 M31 ;	Drilling hole 2
C180.0 M31 ;	Drilling hole 3
C270.0 M31 ;	Drilling hole 4
G80 M05 ;	Canceling the drilling cycle and stopping drill rotation
M50 ;	Setting C-axis index mode off

13.3.4 Canned Cycle for Drilling Cancel (G80)

G80 cancels canned cycle.

Format

```
G80 ;
```

Explanations

Canned cycle for drilling is canceled to perform normal operation. Point R and point Z are cleared. Other drilling data is also canceled (cleared).

Examples

M51 ;	Setting C-axis index mode ON
M3 S2000 ;	Rotating the drill
G00 X50.0 C0.0 ;	Positioning the drill along the X- and C-axes.
G83 Z-40.0 R-5.0 P500 F5.0 M31 ;	Drilling hole 1
C90.0 M31 ;	Drilling hole 2
C180.0 M31 ;	Drilling hole 3
C270.0 M31 ;	Drilling hole 4
G80 M05 ;	Canceling the drilling cycle and stopping drill rotation
M50 ;	Setting C-axis index mode off

13.3.5

Precautions to be Taken by Operator

- **Reset and emergency stop**

Even when the controller is stopped by resetting or emergency stop in the course of drilling cycle, the drilling mode and drilling data are saved ; with this mind, therefore, restart operation.
- **Single block**

When drilling cycle is performed with a single block, the operation stops at the end points of operations 1, 2, 6 in Fig. 13.3 (a).
Consequently, it follows that operation is started up 3 times to drill one hole. The operation stops at the end points of operations 1, 2 with the feed hold lamp ON. The operation stops in the feed hold conditions at the end point of operation 6 if the repeat remains, and it stops in stop conditions in other cases.
- **Feed hold**

When “Feed Hold” is applied between operations 3 and 5 by G84/G88, the feed hold lamp lights up immediately if the feed hold is applied again to operation 6.
- **Override**

During operation with G84 and G88, the feedrate override is 100%.

13.4 CANNED GRINDING CYCLE (FOR GRINDING MACHINE)

There are four grinding canned cycles : the traverse grinding cycle (G71), traverse direct fixed-dimension grinding cycle, oscillation grinding cycle, and oscillation direct fixed-dimension grinding cycle.

With a machine tool that allows canned cycles for grinding to be used, the multiple repetitive canned cycle for turning cannot be used.

13.4.1 Traverse Grinding Cycle (G71)

Format

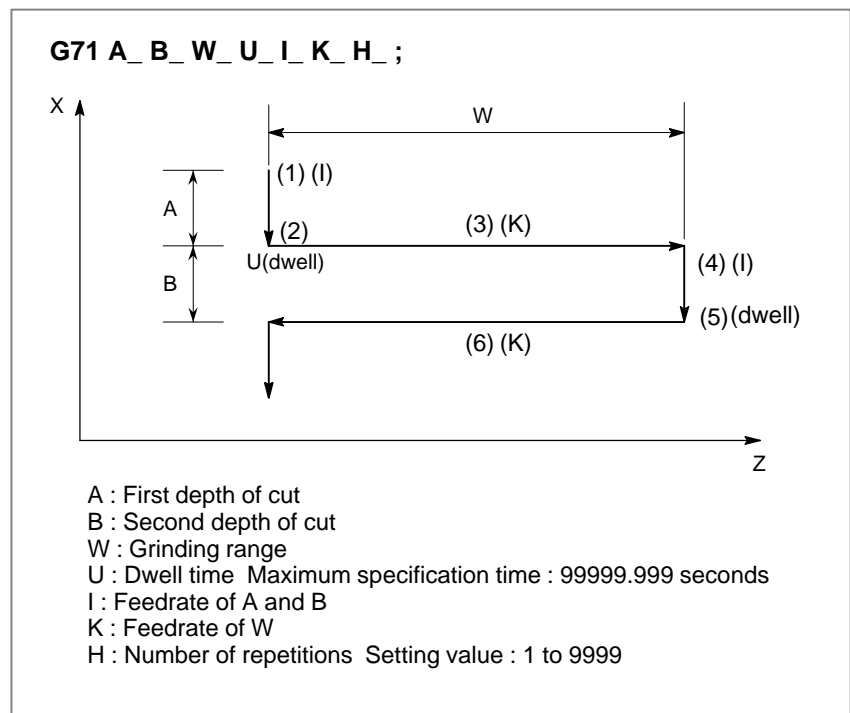

Explanations

The specification ranges and units of the canned cycle for grinding are described below.

Move command Range : ± 8 digits

Units : 1 μm /0.0001 inch

Feedrate Range

Feed per minute : 0.001 to 240000 mm/min
 0.0001 to 9600 inch/min
 (for 1 μm /0.0001 inch)

Feed per revolution : 0.00001 to 500 mm/rev
 0.00001 to 9 inch/rev

A, B, and W are to be specified in an incremental mode.

In the case of a single block, the operations 1, 2, 3, 4, 5, and 6 are performed with one cycle start operation.

A=B=0 results in a spark-out.

13.4.2 Traverse Direct Fixed-dimension Grinding Cycle (G72)

Format

```
G72 P_A_B_W_U_I_K_H ;
```

P : Gauge number (1 to 4)
 A : First depth of cut
 B : Second depth of cut
 W : Grinding range
 U : Dwell time Maximum specification time : 99999.999seconds
 I : Feedrate of A and B
 K : Feedrate of W
 H : Number of repetitions Setting value : 1 to 9999

Explanations

When the multistage skip operation is used, a gauge number can be specified. The method of gauge number specification is the same as the method of multistage skip function. When the multistage skip operation is not used, the conventional skip signal is valid.

The same specifications as G71 apply except for gauge number specification.

• Operation at the time of skip signal input

1. When the tool moves along the Z-axis to grind a workpiece, if a skip signal is input, the tool returns to the Z coordinate where the cycle started after the tool reaches the end of the specified grinding area.

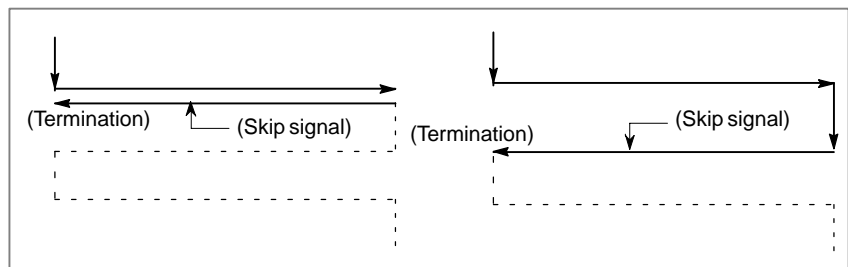

2. When the tool cuts a workpiece along the X-axis, if a skip signal is input, the tool stops cutting immediately and returns to the Z coordinate where the cycle started.

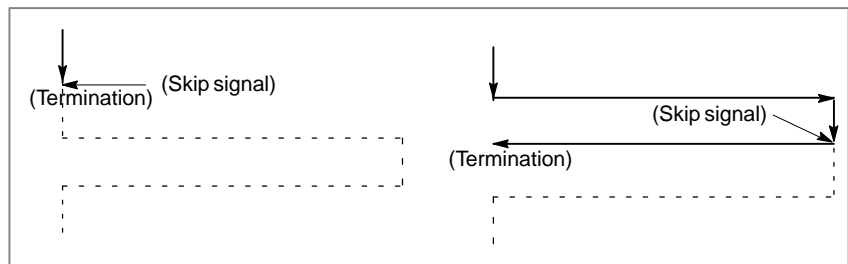

3. The skip signal is valid during dwell, without being affected by parameters DS1 to DS8 (No. 6206#0 to #7). Dwell is immediately stopped for return to the Z axis coordinate where the cycle started.

13.4.3 Oscillation Grinding Cycle (G73)

Format

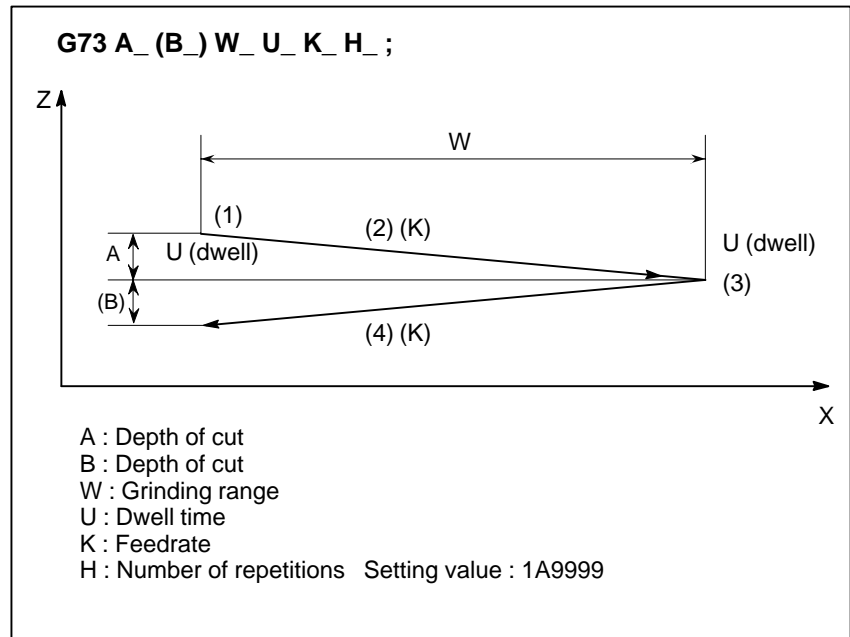

Explanations

A, B, and W are to be specified in an incremental mode.
 In the case of a single block, the operations 1, 2, 3, and 4 are performed with one cycle start operation.
 The specification of B is valid only for a specified block. This is not associated with B of the G71 or G72 cycle.

13.4.4 Oscillation Direct Fixed-Dimension Grinding Cycle

Format

G74 P_ A_ (B_) W_ U_ K_ H_ ;

P : Gauge number (1 to 4)
 A : Depth of cut
 B : Depth of cut
 W : Grinding range
 U : Dwell time
 K : Feedrate of W
 H : Number of repetitions Setting value : 1 to 9999

Explanations

When the multistage skip operation is used, a gauge number can be specified. The method of gauge number specification is the same as the method of multistage skip function. When the multistage skip operation is not used, the conventional skip signal is valid.

The same specifications as G73 apply to the other items.

• Operation at the time of skip signal input

1. When the tool moves along the Z-axis to grind a workpiece, if a skip signal is input, the tool returns to the Z coordinate where the cycle started after the tool reaches the end of the specified grinding area.

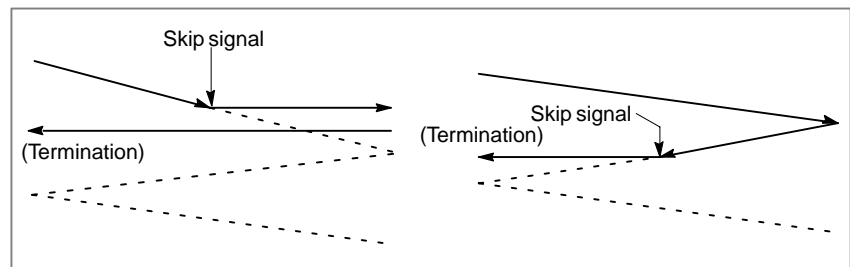

2. The skip signal is valid during dwell, without being affected by parameters DS1 to DS8 (No. 6206#0 to #7). Dwell is immediately stopped for return to the Z axis coordinate where the cycle started.

NOTE

- 1 The data items A, B, W, I, and K in a canned cycle are modal values common to G71 through G74. The data items A, B, W, U, I and K are cleared when a one-shot G code other than G04 or a 01 group G code other than G71 to G74 is specified.
- 2 No B code can be specified in the canned cycle mode.

13.5 CHAMFERING AND CORNER R

A chamfer or corner can be inserted between two blocks which intersect at a right angle as follows :

- Chamfering
Z → X

Format	Tool movement
<p>G01 Z(W) _ I (C) $\pm i$;</p> <p>Specifies movement to point b with an absolute or incremental command in the figure on the right.</p>	<p>Moves as a→d→c (For -X movement, -i)</p>

Fig. 13.5 (a) Chamfering (Z→X)

- Chamfering
X → Z

Format	Tool movement
<p>G01 X(U) _ K (C) $\pm k$;</p> <p>Specifies movement to point b with an absolute or incremental command in the figure on the right.</p>	<p>Moves as a→d→c (For -Z movement, -k)</p>

Fig. 13.5 (b) Chamfering (X→Z)

- Corner R
Z → X

Format	Tool movement
<p>G01 Z(W) _ R $\pm r$;</p> <p>Specifies movement to point b with an absolute or incremental command in the figure on the right.</p>	<p>Moves as a→d→c (For -X movement, -r)</p>

Fig. 13.5 (c) Corner R (Z→X)

● **Corner R**
X → Z

Format	Tool movement
<p>G01 X(U) _ R ±r ;</p> <p>Specifies movement to point b with an absolute or incremental command in the figure on the right.</p>	 <p>(For -x movement, -r)</p> <p>Moves as a→d→c</p>

Fig. 13.5 (d) Corner R (X→Z)

Explanations

The movement for chamfering or corner R must be a single movement along the X or Z axis in G01 mode. The next block must be a single movement along the X or Z axis perpendicular to the former block. I or K, and R always specify a radius value.

Note that the start point for a command specified in a block following a chamfering or corner-R block is not point c but point b shown in Figs. 13.5 (a) to (d). In incremental programming, specify a distance from point b.

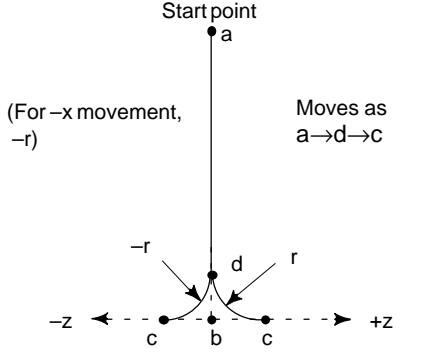
Examples

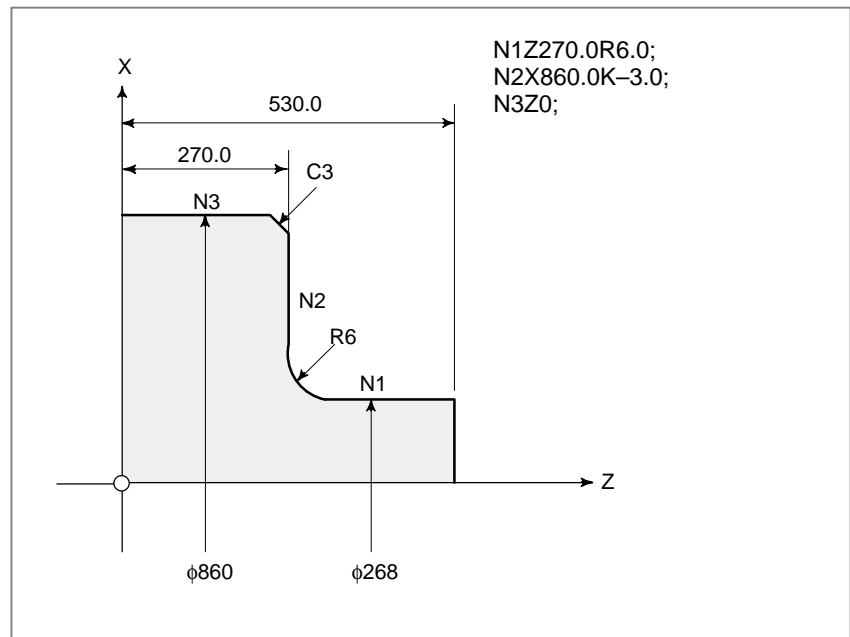

NOTE

- 1 The following commands cause an alarm.
 - 1) One of I, K, or R is commanded when X and Z axes are specified by G01.
(P/S alarm No. 054)
 - 2) Move amount of X or Z is less than chamfering value and corner R value in the block where chamfering and corner R are specified. (P/S alarm No. 055)
 - 3) Next block to the block where chamfering and corner R were specified, has not G01 command. (P/S alarm No. 051, 052)
 - 4) If more than one of I, K, and R are specified in G01, P/S alarm No. 053 is issued.
- 2 A single block stops at point c in Fig. 13.5 (a) — (d) not at point d.
- 3 Chamfering and corner R cannot be applied to a thread cutting block.
- 4 C can be used instead of I or K as an address for chamfering on the system which does not use C as an axis name. To use C for an address for chamfering, fix parameter CCR No. 3405#4 to 1.
- 5 If both C and R are specified with G01 in a block, the address specified last is valid.
- 6 Neither chamfering nor corner-R machining can be specified in direct drawing dimension programming.

13.6 MIRROR IMAGE FOR DOUBLE TURRET (G68, G69)

Format

G68 : Double turret mirror image on
G69 : Mirror image cancel

Explanations

Mirror image can be applied to X-axis with G code.

When G68 is designated, the coordinate system is shifted to the mating turret side, and the X-axis sign is reversed from the programmed command to perform symmetrical cutting. To use this function, set the distance between the two turrets to a parameter (No. 1290).

Examples

- Double turret programming

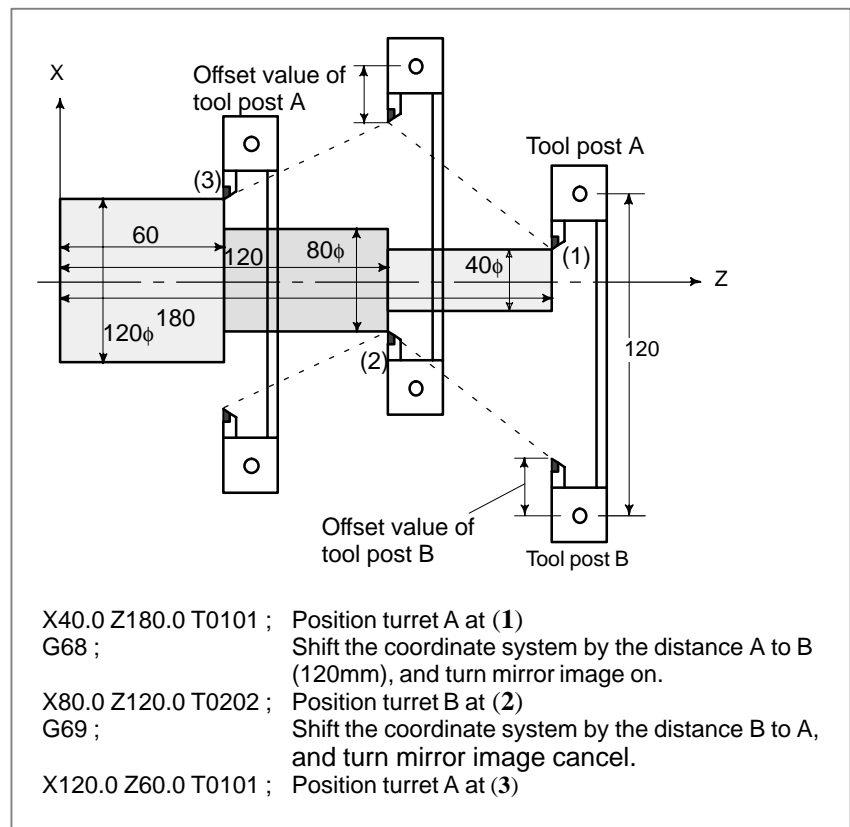

13.7 DIRECT DRAWING DIMENSIONS PROGRAMMING

Angles of straight lines, chamfering value, corner rounding values, and other dimensional values on machining drawings can be programmed by directly inputting these values. In addition, the chamfering and corner rounding can be inserted between straight lines having an optional angle. This programming is only valid in memory operation mode.

Format

Table 13.7 Commands table

	Commands	Movement of tool
1	$X_{2_} Z_{2_}, A_{_};$	
2	$,A_{1_};$ $X_{3_} Z_{3_}, A_{2_};$	
3	$X_{2_} Z_{2_}, R_{1_};$ $X_{3_} Z_{3_};$ or $,A_{1_}, R_{1_};$ $X_{3_} Z_{3_}, A_{2_};$	
4	$X_{2_} Z_{2_}, C_{1_};$ $X_{3_} Z_{3_};$ or $,A_{1_}, C_{1_};$ $X_{3_} Z_{3_}, A_{2_};$	

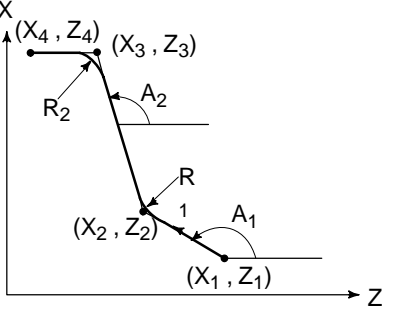
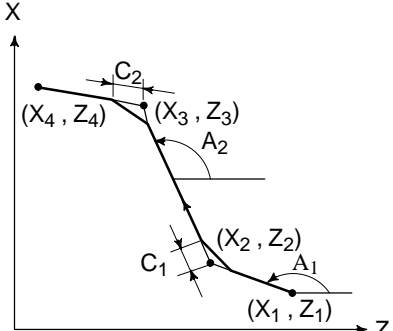
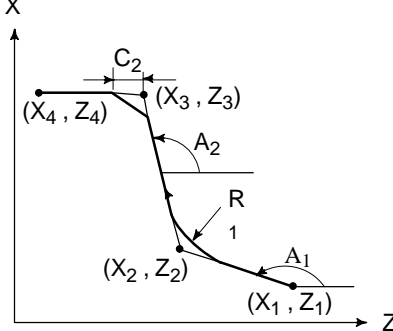
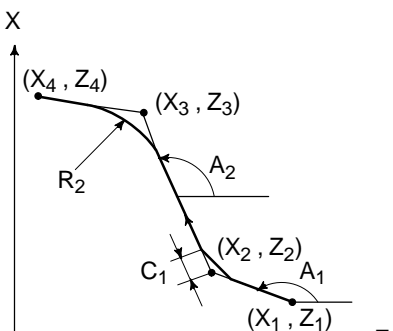
	Commands	Movement of tool
5	$X_2_Z_2-, R_1-;$ $X_3_Z_3-, R_2-;$ $X_4_Z_4-;$ or $.A_1-, R_1-;$ $X_3_Z_3-, A_2-, R_2-;$ $X_4_Z_4-;$	
6	$X_2_Z_2-, C_1-;$ $X_3_Z_3-, C_2-;$ $X_4_Z_4-;$ or $.A_1-, C_1-;$ $X_3_Z_3-, A_2-, C_2-;$ $X_4_Z_4-;$	
7	$X_2_Z_2-, R_1-;$ $X_3_Z_3-, C_2-;$ $X_4_Z_4-;$ or $.A_1-, R_1-;$ $X_3_Z_3-, A_2-, C_2-;$ $X_4_Z_4-;$	
8	$X_2_Z_2-, C_1-;$ $X_3_Z_3-, R_2-;$ $X_4_Z_4-;$ or $.A_1-, C_1-;$ $X_3_Z_3-, A_2-, R_2-;$ $X_4_Z_4-;$	

Explanations

A program for machining along the curve shown in Fig. 13.7 (a) is as follows :

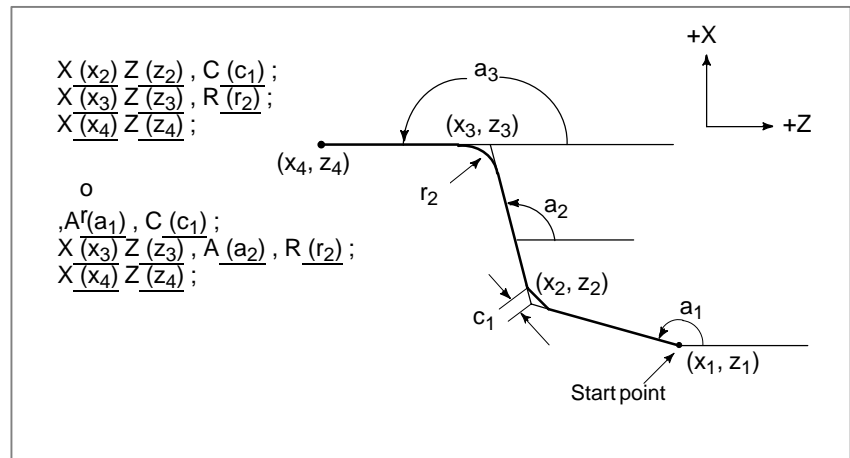

Fig. 13.7 Machining Drawing (example)

For command a straight line, specify one or two out of X, Z, and A. If only one is specified, the straight line must be primarily defined by a command in the next block.

To command the degree of a straight line or the value of chamfering or corner R, command with a comma (,) as follows :

- , A_
- , C_
- , R_

By specifying 1 to parameter CCR No. 3405#4 on the system which does not use A or C as an axis name, the degree of a straight line or the value of chamfering or corner R can be commanded without a comma (,) as follows :

- A_
- C_
- R_

NOTE

- 1 The following G codes are not applicable to the same block as commanded by direct input of drawing dimensions or between blocks of direct input of drawing dimensions which define sequential figures.
 - 1) G codes (other than G04) in group 00.
 - 2) G02, G03, G90, G92, and G94 in group 01.
- 2 Corner rounding cannot be inserted into a threading block.
- 3 Chamfering and corner R using the direct input of drawing dimensions cannot be used simultaneously with the chamfering and corner R described in Section 13.5. (The option for chamfering and corner R and that for the direct input of drawing dimensions cannot be selected simultaneously.)
- 4 When the end point of the previous block is determined in the next block according to sequential commands of direct input of drawing dimensions, the single block stop is not done, but the feed hold stop is done at the end point of the previous block.
- 5 The angle allowance in calculating the point of intersection in the program below is $\pm 1^\circ$.
(Because the travel distance to be obtained in this calculation is too large.)
 - 1) X_ , A_ ; (If a value within $0^\circ \pm 1^\circ$ or $180^\circ \pm 1^\circ$ is specified for the angle instruction, the P/S alarm No.057 occurs.)
 - 2) Z_ , A_ ; (If a value within $90^\circ \pm 1^\circ$ or $270^\circ \pm 1^\circ$ is specified for the angle instruction, the P/S alarm No. 057 occurs.)
- 6 An alarm occurs if the angle made by the 2 lines is within $\pm 1^\circ$ when calculating the point of intersection.
- 7 Chamfering or corner % is ignored if the angle made by the 2 lines is within $\pm 1^\circ$.
- 8 Both a dimensional command (absolute programming) and angle instruction must be specified in the block following a block in which only the angle instruction is specified.
(Example)

```

      N1 X_ , A_ , R_ ;
      N2, A_ ;
      N3 X_ Z_ , A_ ;
      
```

 (In addition to the dimensional command, angle instruction must be specified in block No. 3.)

Examples

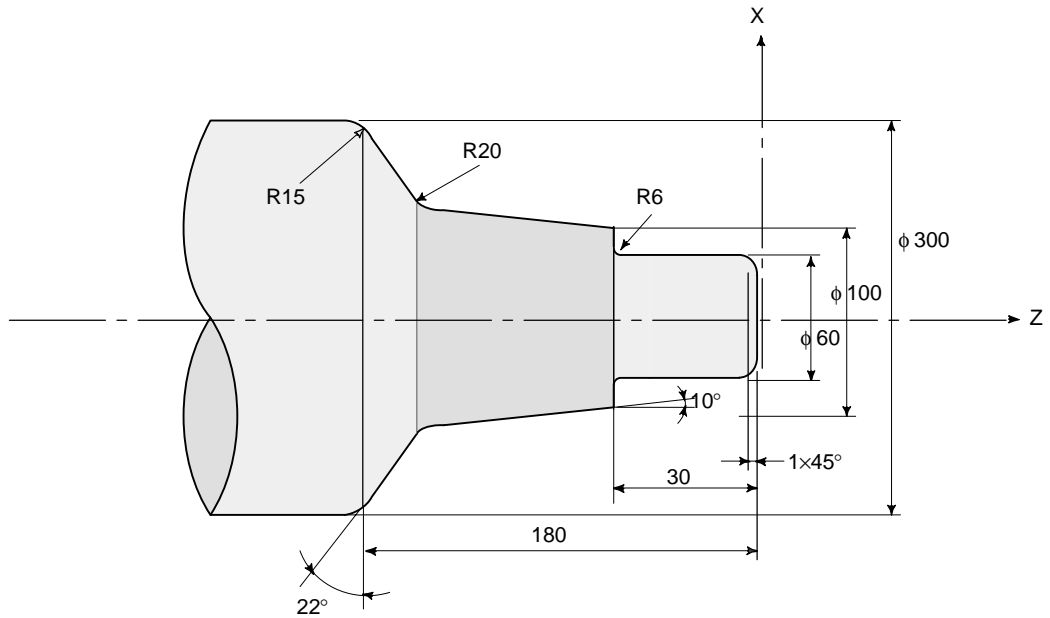

(Diameter specification, metric input)

```

N001 G50 X0.0 Z0.0 ;
N002 G01 X60.0, A90.0, C1.0 F80 ;
N003 Z-30.0, A180.0, R6.0 ;
N004 X100.0, A90.0 ;
N005 ,A170.0, R20.0 ;
N006 X300.0 Z-180.0, A112.0, R15.0 ;
N007 Z-230.0, A180.0 ;
:
:

```

13.8 RIGID TAPPING

Front face tapping cycles (G84) and side face tapping cycles (G88) can be performed either in conventional mode or rigid mode.

In conventional mode, the spindle is rotated or stopped, in synchronization with the motion along the tapping axis according to miscellaneous functions M03 (spindle CW rotation), M04 (spindle CCW rotation), and M05 (spindle stop).

In rigid mode, the spindle motor is controlled in the same way as a control motor, by the application of compensation to both motion along the tapping axis and that of the spindle.

For rigid tapping, each turn of the spindle corresponds to a certain amount of feed (screw lead) along the spindle axis. This also applies to acceleration/deceleration. This means that rigid tapping does not demand the use of float tappers as in the case of conventional tapping, thus enabling high-speed, high-precision tapping.

When the system is equipped with the optional multispindle control function, the second spindle can be used for rigid tapping.

**13.8.1
Front Face Rigid
Tapping Cycle (G84) /
Side Face Rigid
Tapping Cycle (G88)**

Controlling the spindle motor in the same way as a servo motor in rigid mode enables high-speed tapping.

Format

<p>G84 X(U)_ C(H)_ Z(W)_ R_ P_ F_ M_ K_ ; or G88 Z(W)_ C(H)_ X(U)_ R_ P_ F_ M_ K_ ;</p> <p>X_ C_ or Z_ C_ : Hole position data Z_ or X_ : The distance from point R to the bottom of the hole R_ : The distance from the initial level to point R level P_ : Dwell time at the bottom of a hole F_ : Cutting feedrate K_ : Number of repeats (When it is needed.) M_ : M code for C-axis clamp (when it is needed.)</p>	
G84 or G88 (G98 mode)	G84 or G88 (G99 mode)

Explanations

Once positioning for the X-axis (G84) or Z-axis (G88) has been completed, the spindle is moved, by rapid traverse, to point R. Tapping is performed from point R to point Z, after which the spindle stops and observes a dwell time. Then, the spindle starts reverse rotation, retracts to point R, stops rotating, then moves to the initial level by rapid traverse. During tapping, the feedrate override and spindle override are assumed to be 100%. For retraction (operation 5), however, a fixed override of up to 2000% can be applied by setting parameter No. 5211 (RGOVR), bit 4 (DOV) of parameter No. 5200, and bit 3 (OVU) of parameter of No. 5201.

● **Rigid mode**

Rigid mode can be specified by applying any of the following methods:

- Specifying M29S***** before a tapping block
- Specifying M29S***** within a tapping block
- Handling G84 or G88 as a G code for rigid tapping (Set bit 0 (G84) of parameter No. 5200 to 1.)

- **Thread lead**

In feed per minute mode, the feedrate divided by the spindle speed is equal to the thread lead. In feed per rotation mode, the feedrate is equal to the thread lead.

Limitations

- **S commands**

When a value exceeding the maximum rotation speed for the gear being used is specified, P/S alarm No. 200 is issued. For an analog spindle, when a command is specified such that more than 4095 pulses are generated during 8 ms (detection unit), P/S alarm No. 202 is issued. For a serial spindle, when a command is specified such that more than 32767 pulses are generated during 8 ms (detection unit), P/S alarm No. 202 is issued.

<Example>

For a built-in motor equipped with a detector having a resolution of 4095 pulses per rotation, the maximum spindle speed during rigid tapping is as follows:

For an analog spindle

$$(4095 \times 1000 \div 8 \times 60) \div 4095 = 7500 \text{ (rpm)}$$

For a serial spindle

$$(32767 \times 1000 \div 8 \times 60) \div 4095 = 60012 \text{ (rpm) [Note: Ideal value]}$$

- **F commands**

Specifying a value larger than the upper limit for cutting feed will cause P/S alarm No. 201 to be issued.

- **M29**

Specifying an S command or axis movement between M29 and M84 will cause P/S alarm No. 203 to be issued. Specifying M29 during a tapping cycle will cause P/S alarm No. 204 to be issued.

- **Rigid tapping command
M code**

The M code used to specify rigid tapping mode is usually set in parameter No. 5210. To set a value of more than 255, however, use parameter No. 5212.

- **Maximum position
deviation during
movement along the
tapping axis**

The maximum position deviation during movement along the tapping axis in rigid tapping mode is usually set in parameter No. 5310. Use parameter No. 5314, however, when setting a value of more than 32767, for example, according to the resolution of the detector being used.

- **R**

The value of R must be specified in a block which performs drilling. If the value is specified in a block which does not perform drilling, it is not stored as modal data.

- **Cancellation**

G00 to G03 (G codes in group 01) must not be specified in a block containing G84 or G88. If specified, G84 or G88 in that block is canceled.

- **Tool position offset**

Any tool position offset is ignored in canned cycle mode.

- **Units for F**

	Metric input	Inch input	Remark
G98	1 mm/min	0.01inch/min	Decimal point allowed
G99	0.01mm/rev	0.0001inch/rev	Decimal point allowed

Examples

Tapping axis feedrate: 1000 mm/min

Spindle speed: 1000 min⁻¹

Screw lead: 1.0 mm

<Programming for feed per minute>

G98 ;	Command for feed per minute
G00 X100.0 ;	Positioning
M29 S1000 ;	Command for specifying rigid mode
G84 Z-100.0 R-20.0 F1000 ;	Rigid tapping

<Programming for feed per rotation>

G99 ;	Command for feed per rotation
G00 X100.0 ;	Positioning
M29 S1000 ;	Command for specifying rigid mode
G84 Z-100.0 R-20.0 F1.0 ;	Rigid tapping

13.9 THREE- DIMENSIONAL COORDINATE CONVERSION (G68.1, G69.1)

Coordinate conversion about an axis can be carried out if the center of rotation, direction of the axis of rotation, and angular displacement are specified. This function is very useful for three-dimensional machining such as B-axis machining. For example, if a program specifying machining on the ZX plane is converted by the three-dimensional coordinate conversion function, the identical machining can be executed on a desired plane in three-dimensional space.

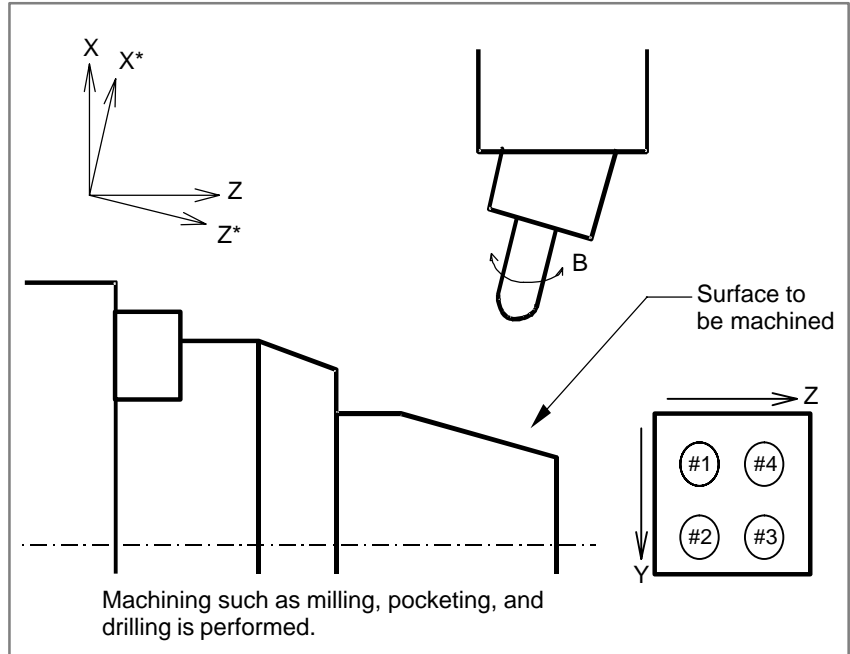

Format

G68.1	$X_p \ x_1 \ Y_p \ y_1 \ Z_p \ z_1 \ I \ i_1 \ J \ j_1 \ K \ k_1 \ R \ \alpha$;	Starting three-dimensional coordinate conversion
.		} Three-dimensional coordinate conversion mode
.		
.		
G69.1 ;		Canceling three-dimensional coordinate conversion
	X_p, Y_p, Z_p :	Center of rotation (absolute coordinates) on the X, Y, and Z axis or parallel axes
	I, J, K :	Direction of the axis of rotation
	R :	Angular displacement

Explanations

- **Command for three-dimensional coordinate conversion (program coordinate system)**

N1 G68.1 $X_p \ x_1 \ Y_p \ y_1 \ Z_p \ z_1 \ I \ i_1 \ J \ j_1 \ K \ k_1 \ R \ \alpha$;
 N2 G68.1 $X_p \ x_2 \ Y_p \ y_2 \ Z_p \ z_2 \ I \ i_2 \ J \ j_2 \ K \ k_2 \ R \ \beta$;
 N3
 :
 Nn G69.1 ;

Three-dimensional coordinate conversion can be executed twice.

In the N1 block, specify the center, direction of the axis of rotation, and angular displacement of the first rotation. When this block is executed, the center of the original coordinate system is shifted to (x_1, y_1, z_1) , then rotated around the vector (i_1, j_1, k_1) by angular displacement α . The new coordinate system is called $X'Y'Z'$. In the N2 block, specify the center, direction of the axis of rotation, and angular displacement of the second rotation. In the N2 block, specify coordinates and the angle with the coordinate system formed after the N1 block in $X_p, Y_p, Z_p, I, J, K,$ and R . When the N2 block is executed, the $X'Y'Z'$ coordinate system is shifted to (x_2, y_2, z_2) , then rotated around the vector (i_2, j_2, k_2) by angular displacement β . The newest coordinate system is called $X''Y''Z''$. In the subsequent N3 block, coordinates in the $X''Y''Z''$ coordinate system are specified with $X_p, Y_p,$ and Z_p . The $X''Y''Z''$ coordinate system is called the program coordinate system.

If (X_p, Y_p, Z_p) is not specified in the N2 block, (X_p, Y_p, Z_p) in the N1 block is assumed to be the center of the second rotation (the N1 and N2 blocks have a common center of rotation). If the coordinate system is to be rotated only once, the N2 block need not be specified.

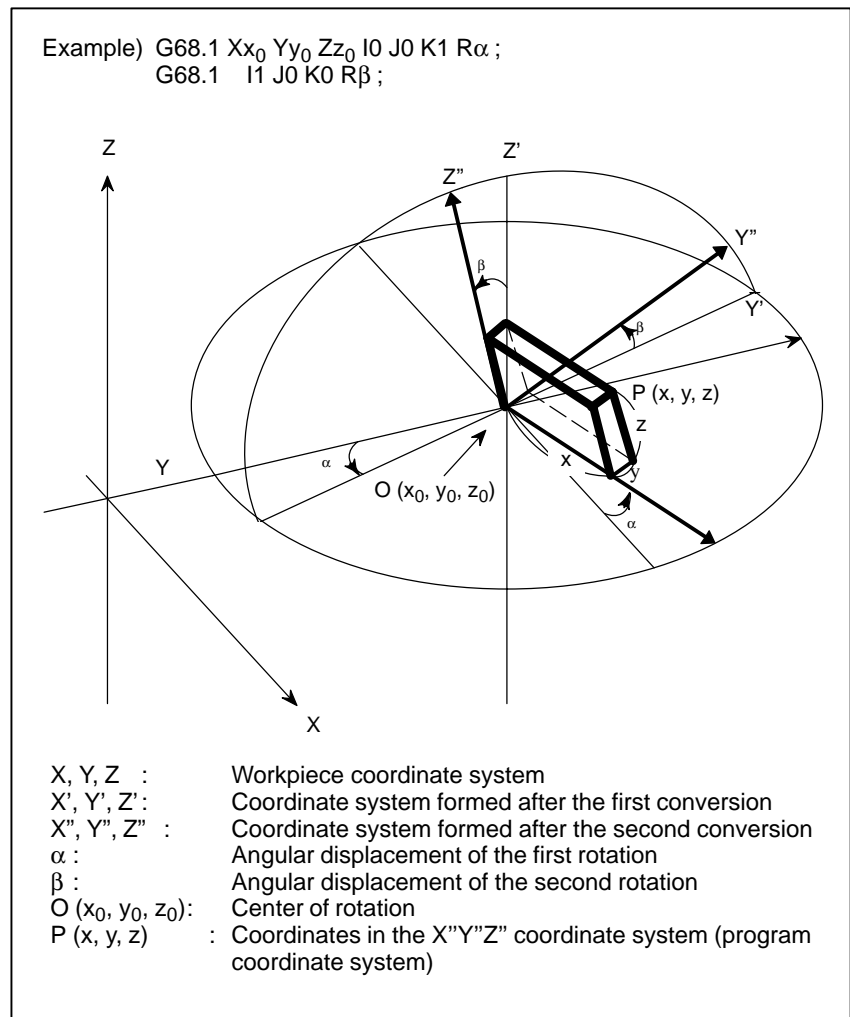

- **Format error**

If one of the following format errors is detected, P/S alarm No. 5044 occurs:

1. When I, J, or K is not specified in a block with G68.1
(a parameter of coordinate system rotation is not specified)
2. When I, J, and K are all set to 0 in a block with G68.1
3. When R is not specified in a block with G68.1

- **Center of rotation**

Specify absolute coordinates with Xp, Yp, and Zp in the G68.1 block.

- **Equation for three-dimensional coordinate conversion**

The following equation shows the general relationship between (x, y, z) in the program coordinate system and (X, Y, Z) in the original coordinate system (workpiece coordinate system).

$$\begin{pmatrix} X \\ Y \\ Z \end{pmatrix} = \begin{pmatrix} M_1 \end{pmatrix} \begin{pmatrix} x \\ y \\ z \end{pmatrix} + \begin{pmatrix} x_1 \\ y_1 \\ z_1 \end{pmatrix}$$

When conversion is carried out twice, the relationship is expressed as follows:

$$\begin{pmatrix} X \\ Y \\ Z \end{pmatrix} = \begin{pmatrix} M_1 \end{pmatrix} \begin{pmatrix} M_2 \end{pmatrix} \begin{pmatrix} x \\ y \\ z \end{pmatrix} + \begin{pmatrix} M_1 \end{pmatrix} \begin{pmatrix} x_2 \\ y_2 \\ z_2 \end{pmatrix} + \begin{pmatrix} x_1 \\ y_1 \\ z_1 \end{pmatrix}$$

X, Y, Z : Coordinates in the original coordinate system
(workpiece coordinate system or machine coordinate system)

x, y, z : Programmed value
(coordinates in the program coordinate system)

x₁, y₁, z₁ : Center of rotation of the first conversion

x₂, y₂, z₂ : Center of rotation of the second conversion
(coordinates in the coordinate system formed after the first conversion)

M₁ : First conversion matrix

M₂ : Second conversion matrix

M₁ and M₂ are conversion matrices determined by an angular displacement and rotation axis. Generally, the matrices are expressed as shown below:

$$\begin{pmatrix} n_1^2 + (1 - n_1^2) \cos\theta & n_1 n_2 (1 - \cos\theta) - n_3 \sin\theta & n_1 n_3 (1 - \cos\theta) + n_2 \sin\theta \\ n_1 n_2 (1 - \cos\theta) + n_3 \sin\theta & n_2^2 + (1 - n_2^2) \cos\theta & n_2 n_3 (1 - \cos\theta) - n_1 \sin\theta \\ n_1 n_3 (1 - \cos\theta) - n_2 \sin\theta & n_2 n_3 (1 - \cos\theta) + n_1 \sin\theta & n_3^2 + (1 - n_3^2) \cos\theta \end{pmatrix}$$

n₁ : Cosine of the angle made by the rotation axis and X-axis $\frac{i}{p}$

n₂ : Cosine of the angle made by the rotation axis and Y-axis $\frac{j}{p}$

n₃ : Cosine of the angle made by the rotation axis and Z-axis $\frac{k}{p}$

θ: Angular displacement

Value p is obtained by the following:

$$p = \sqrt{i^2 + j^2 + k^2}$$

Conversion matrices for rotation on two-dimensional planes are shown below:

(1) Coordinate conversion on the XY plane

$$M = \begin{pmatrix} \cos\theta & -\sin\theta & 0 \\ \sin\theta & \cos\theta & 0 \\ 0 & 0 & 1 \end{pmatrix}$$

(2) Coordinate conversion on the ZY plane

$$M = \begin{pmatrix} 1 & 0 & 0 \\ 0 & \cos\theta & -\sin\theta \\ 0 & \sin\theta & \cos\theta \end{pmatrix}$$

(3) Coordinate conversion on the ZX plane

$$M = \begin{pmatrix} \cos\theta & 0 & \sin\theta \\ 0 & 1 & 0 \\ -\sin\theta & 0 & \cos\theta \end{pmatrix}$$

- **Three basic axes and their parallel axes**

Three-dimensional coordinate conversion can be applied to a desired combination of three axes selected out of the basic three axes (X, Y, Z) and their parallel axes. The three-dimensional coordinate system subjected to three-dimensional coordinate conversion is determined by axis addresses specified in the G68.1 block. If Xp, Yp, or Zp is not specified, X, Y, or Z of the basic three axes is assumed. However, if the basic three axes are not specified in parameter 1022, P/S alarm No. 048 occurs. In a single G68.1 block, both a basic axis and a parallel axis cannot be specified. If this is attempted, P/S alarm No.047 occurs.

(Example)

When U-axis, V-axis, and W-axis are parallel to the X-axis, Y-axis, and Z-axis respectively (when G code system B or C is used.)

G68.1 X_I_J_K_R_; XYZ coordinate system

G68.1 U_V_Z_I_J_K_R_; UVZ coordinate system

G68.1 W_I_J_K_R_; XYW coordinate system

- **Specifying the second conversion**

Three-dimensional coordinate conversion can be executed twice. The center of rotation of the second conversion must be specified with the axis addresses specified for the first conversion. If the axis addresses of the second conversion are different from the axis addresses of the first conversion, the different axis addresses are ignored. An attempt to execute three-dimensional coordinate conversion three or more times causes P/S alarm No.5043.

- **Angular displacement R**

A positive angular displacement R indicates a clockwise rotation along the axis of rotation. Specify angular displacement R in 0.001 degrees within the range of -360000 to 360000.

- **G codes that can be specified**

The following G codes can be specified in the three-dimensional coordinate conversion mode:

G00	Positioning
G01	Linear interpolation
G02	Circular interpolation (clockwise)
G03	Circular interpolation (counterclockwise)
G04	Dwell
G10	Data setting
G17	Plane selection (XY)
G18	Plane selection (ZX)
G19	Plane selection (YZ)
G28	Reference position return
G29	Return from the reference position
G30	Return to the second, third, or fourth reference position
G40	Canceling tool nose radius compensation
G41	Tool nose radius compensation to the left
G42	Tool nose radius compensation to the right
G53	Selecting the machine coordinate system
G65	Custom macro calling
G66	Continuous-state custom macro calling
G67	Canceling continuous-state custom macro calling
G80	Canceling a drilling cycle
G83 to G89	Drilling cycle
G90	Absolute mode (when G code system B or C is used.)
G91	Incremental mode (when G code system B or C is used.)
G94	Feed per minute (when G code system B or C is used.)
G95	Feed per rotation (when G code system B or C is used.)
G98	Canned cycle (return to the initial level) (when G code system B or C is used.)
G99	Canned cycle (return to the level of point R) (when G code system B or C is used.)

- **Rapid traverse rate in drilling of a canned cycle for drilling**

In three-dimensional coordinate conversion mode, rapid traverse rate in drilling by a canned cycle for drilling equals the cutting feedrate specified in parameter 5412. If the parameter is set to 0, the rapid traverse rate equals the maximum cutting feedrate.

- **Compensation functions (tool nose radius compensation)**

If tool nose radius compensation is specified with three-dimensional coordinate conversion, compensation is performed first, followed by three-dimensional coordinate conversion.

- **Relationship between three-dimensional and two-dimensional coordinate conversion (G68.1, G69.1)**

Three-dimensional and two-dimensional coordinate conversion use identical G codes (G68.1 and G69.1). A G code specified with I, J, and K is processed as the command for three-dimensional coordinate conversion. A G code not specified with I, J, and K is processed as the command for two-dimensional coordinate conversion.

- **Custom macro system variables**

Coordinates on the workpiece coordinate system are assigned to system variables #5041 to #5048 (current position on each axis).

- **Reset**

If a reset occurs during three-dimensional coordinate conversion mode, the mode is canceled and the continuous-state G code is changed to G69.1.

The D3R bit (bit 2 of parameter 5400) determines whether just the G69.1 code is used to cancel the three-dimensional coordinate conversion mode (G68.1). When this setting is selected, a CNC reset by a reset operation or by an input signal from the PMC will not cancel the three-dimensional coordinate conversion mode.

- **Three-dimensional rigid tapping**

By specifying the rigid tapping command in three-dimensional coordinate conversion mode, tapping can be executed in the direction of the angle programmed by the three-dimensional coordinate conversion command.

In three-dimensional coordinate conversion mode, "Position Error Z", displayed on the spindle adjustment screen, is taken from the longitudinal tapping axis after three-dimensional conversion.

Positioning in three-dimensional coordinate conversion mode must be linear interpolation positioning (the LRP bit (bit 1 of parameter 1401) is set to 1).

Three-dimensional rigid tapping cannot be executed for an axis under simple synchronous control.

Limitations

- **manual intervention**

Three-dimensional coordinate conversion does not affect the degree of manual handle interrupt.

- **Positioning in the machine coordinate system**

Three-dimensional coordinate conversion does not affect positioning in the machine coordinate system (e.g. specified with G28, G30, or G53).

- **Specifying rapid traverse**

Specify linear rapid traverse when three-dimensional coordinate conversion is executed. (Set the LRP bit, bit 1 of parameter No.1401, to 1.)

- **Block with G68.1 or G69.1**

In a block with G68.1 or G69.1, other G codes must not be specified. G68.1 must be specified with I, J, and K.

- **Mirror image**

External mirror image (mirror image by the mirror image signal or setting) cannot be specified.

- **Position display and compensation**

To display the absolute position when three-dimensional coordinate conversion is executed, set bits 4 to 7 of parameter DRL, DRC, DAL, and DAC No.3104 to 0.

- **Three-dimensional coordinate conversion and other continuous-state commands**

Canned cycles G41 or G42 must be nested between G68.1 and G69.1.

(Example)

```

- - - G68.1 X100. Y100. Z100. I0. J0. K1. R45. ;
- - - G41 X_ Z_ I_ K_ ;
      :
      :
- - - G40 ;
      :
      :
- - - G69.1 ;
      :

```

- **Relationship between three-dimensional coordinate conversion and tool offset**

When using a tool offset command, nest the tool offset command within the three-dimensional coordinate conversion mode.

(Example)

```

- - - G68.1 X100. Y100. Z100. I0. J0. K1. R45. ;
      ⋮
      - T0101 ;
      ⋮
      - T0100 ;
      ⋮
- - - G69.1 ;

```

- **PMC axis control**

In the three-dimensional coordinate conversion mode, PMC axis control cannot be performed for the three axes related to the conversion (P/S alarm).

- **Manual operation**

When manual feeding is performed during a three-dimensional coordinate conversion, the tangent velocity in the coordinate system after conversion (program coordinate system) equals the lowest feedrate of those on the selected axes.

- **Workpiece coordinate system**

Avoid changing the workpiece coordinate system in the three-dimensional coordinate conversion mode.

- **Manual reference position return**

Avoid making a manual reference position return in the three-dimensional coordinate conversion mode.

- **Cs contour axis**

When specifying the Cs contour axis and rapid traverse at the same time in the three-dimensional coordinate conversion mode, make a reference position return on the Cs contour axis in advance. If a reference position return is made in the first rapid traverse after the Cs contour axis is selected (bit NRF (bit 1 of parameter 3700) is set to 0), avoid specifying the reference position return command in the three-dimensional coordinate conversion mode.

14

COMPENSATION FUNCTION



This chapter describes the following compensation functions:

14.1 TOOL OFFSET

14.2 OVERVIEW OF TOOL NOSE RADIUS COMPENSATION

14.3 DETAILS OF TOOL NOSE RADIUS COMPENSATION

14.4 CORNER CIRCULAR INTERPOLATION FUNCTION (G39)

**14.5 TOOL COMPENSATION VALUES, NUMBER OF
COMPENSATION VALUES, AND ENTERING VALUES FROM
THE PROGRAM (G10)**

14.6 AUTOMATIC TOOL OFFSET (G36, G37)

14.7 COORDINATE ROTATION (G68.1, G69.1)

14.1 TOOL OFFSET

Tool offset is used to compensate for the difference when the tool actually used differs from the imagined tool used in programming (usually, standard tool).

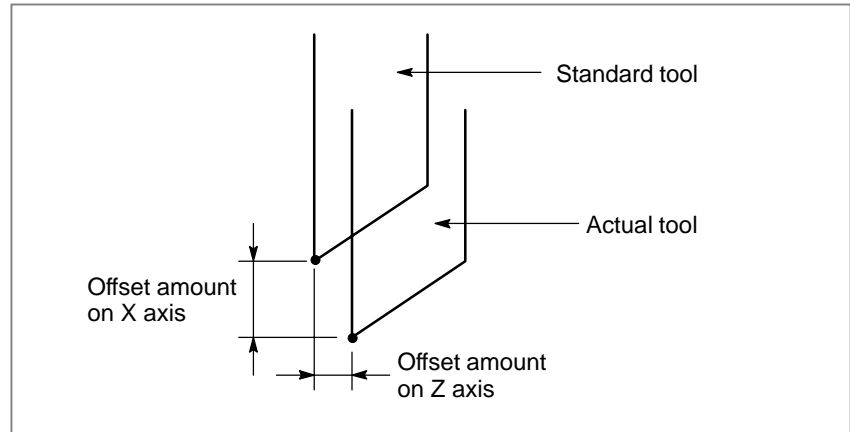

Fig. 14.1 Tool offset

In this unit, there is no G code to specify tool offset. The tool offset is specified by T code.

14.1.1 Tool Geometry Offset and Tool Wear Offset

Tool geometry offset and tool wear offset are possible to divide the tool offset to the tool geometry offset for compensating the tool shape or tool mounting position and the tool wear offset for compensating the tool nose wear.

Total value of tool geometry offset value and tool wear offset value is set as the tool wear offset value without option.

NOTE
Tool geometry offset and tool wear offset are optioned.

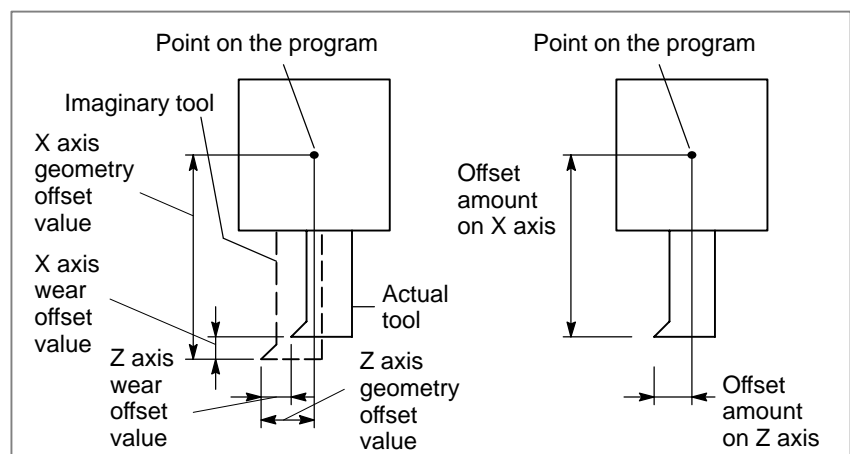

Fig. 14.1.1 (a) Difference the tool geometry offset from tool wear offset

Fig. 14.1.1 (b) Not difference the tool geometry offset from tool wear offset

14.1.2 T Code for Tool Offset

There are two methods for specifying a T code as shown in Table 14.1.2 (a) and Table 14.1.2 (b).

Format

- Lower digit of T code specifies geometry and wear offset number

Table 14.1.2 (a)

Kind of T code	Meaning of T code	Parameter setting for specifying of offset No.	
2-digit command	T ○ ○ ↑ ↑ Tool wear and tool geometry offset number Tool selection	When LD1, bit 0 of parameter No.5002, is set to 1, a tool wear offset number is specified with the last digit of a T code.	When LGN, bit 1 of parameter No.5002, is set to 0, the tool geometry offset number and tool wear offset number specified for a certain tool are the same.
4-digit command	T ○ ○ ○ ○ ↑ ↑ Tool wear and tool geometry offset number Tool selection	When LD1, bit 0 of parameter No.5002, is set to 0, a tool wear offset number is specified with the last two digits of a T code.	

- Lower digit of T code specifies wear offset number and higher digit number specifies tool selection number and geometry offset number

Table 14.1.2 (b)

Kind of T code	Meaning of T code	Parameter setting for specifying of offset No.	
2-digit command	T ○ ○ ↑ ↑ Tool wear offset number Tool selection and tool geometry offset number	When LD1, bit 0 of parameter No.5002, is set to 1, a tool wear offset number is specified with the last digit of a T code.	When LGN, bit 1 of parameter No.5002, is set to 1, the tool geometry offset number and tool wear offset number specified for a certain tool are the same.
4-digit command	T ○ ○ ○ ○ ↑ ↑ Tool wear offset number Tool selection and tool geometry offset number	When LD1, bit 0 of parameter No.5002, is set to 0, a tool wear offset number is specified with the last two digits of a T code.	

14.1.3 Tool Selection

Tool selection is made by specifying the T code corresponding to the tool number. Refer to the machine tool builder's manual for the relationship between the tool selection number and the tool.

14.1.4 Offset Number

Tool offset number has two meanings.

It specifies the offset distance corresponding to the number that is selected to begin the offset function. A tool offset number of 0 or 00 indicates that the offset amount is 0 and the offset is cancelled.

14.1.5 Offset

There are two types of offset. One is tool wear offset and the other is tool geometry offset.

Explanations

- **Tool wear offset**

The tool path is offset by the X, Y, and Z wear offset values for the programmed path. The offset distance corresponding to the number specified by the T code is added to or subtracted from the end position of each programmed block.

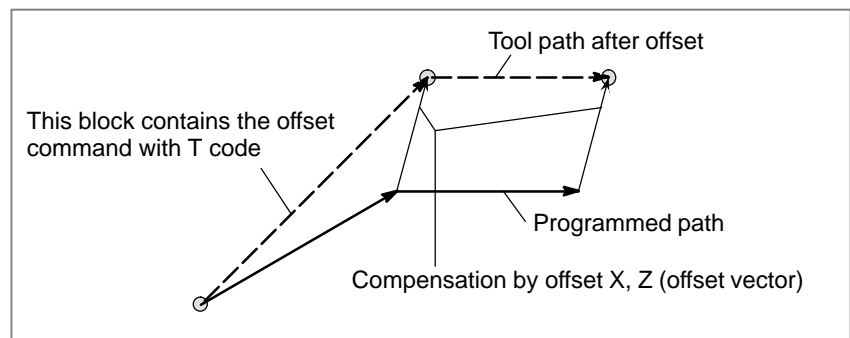

Fig. 14.1.5 (a) Movement of offset (1)

- **Offset vector**

In Fig. 14.1.5 (a), the vector with offset X, Y, and Z is called the offset vector. Compensation is the same as the offset vector.

- **Offset cancel**

Offset is cancelled when T code offset number 0 or 00 is selected. At the end of the cancelled block, the offset vector becomes 0.

N1 X50.0 Z100.0 T0202 ; Creates the offset vector corresponding to offset number 02

N2 X200.0 ;

N3 X100.0 Z250.0 T0200 ; Specifying offset number 00 deletes the offset vector.

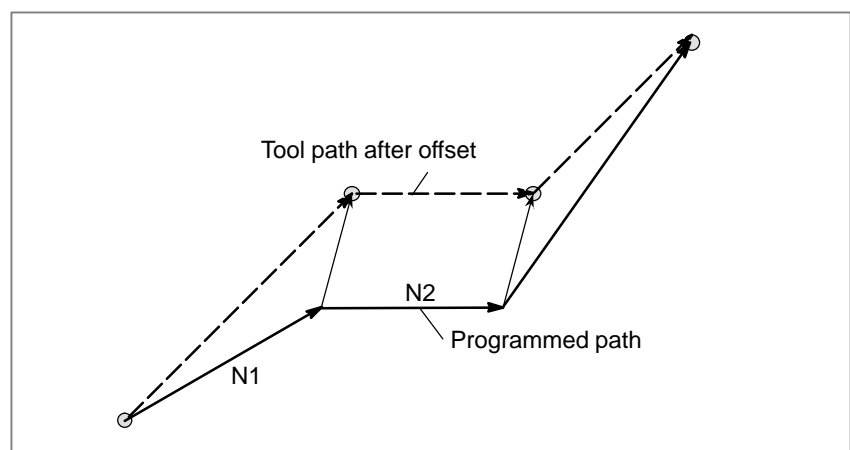

Fig. 14.1.5 (b) Movement of offset (2)

When the power is first turned on, and the reset key on the MDI units is pushed or the reset signal is input to the CNC from the machine tool, the offset is cancelled.

Parameter LVK (No. 5003#6) can be set so that offset will not be cancelled by pressing the reset key or by reset input.

- **Only T code**

When only a T code is specified in a block, the tool is moved by the wear offset value without a move command. The movement is performed at rapid traverse rate in the G00 mode. It is performed at feedrate in other modes.

When a T code with offset number 0 or 00 is specified by itself, movement is performed to cancel the offset.

WARNING

When G50 X_Z_T_ ; is specified
Tool is not moved.

The coordinate system in which the coordinate value of the tool position is (X,Z) is set. The tool position is obtained by subtracting the wear offset value corresponding to the offset number specified in the T code.

- **Tool geometry offset**

With the tool geometry offset, the work coordinate system is shifted by the X, Y, and Z geometry offset amounts. Namely, the offset amount corresponding to the number designated with the code is added to or subtracted from the current position.

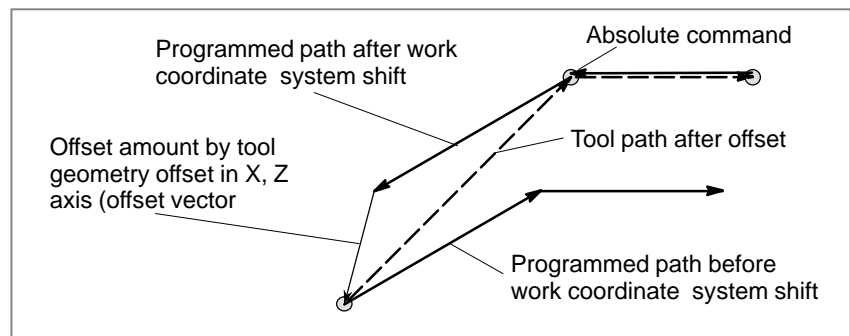

Fig. 14.1.5 (c) Movement of tool geometry offset

NOTE

As well as wear offset, the tool can be compensated by parameter setting LGT(No.5002#4) to add or subtract the programmed end point of each block.

- **Offset cancel**

Specifying offset number 0, 00, or 0000 cancels offset.

NOTE

When LGC, bit 5 of parameter No.5002, is set to 0, specifying offset number 0 or 00 does not cancel offset.

Examples

1. When a tool geometry offset number and tool wear offset number are specified with the last two digits of a T code (when LGN, bit 1 of parameter No. 5002, is set 0),
N1 X50.0 Z100.0 T0202 ; Specifies offset number 02
N2 Z200.0 ;
N3 X100.0 Z250.0 T0200 ; Cancels offset

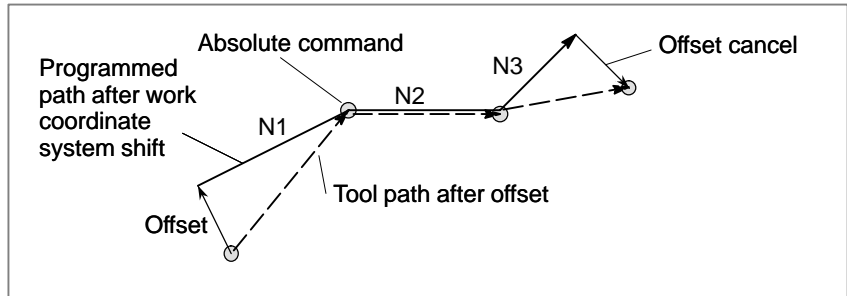

NOTE

When LGC, bit 5 of parameter No.5002, is set to 0, specifying offset number 0 does not cancel tool geometry offset.

2. Assume that geometry offset is not cancelled with offset No. 0 (Set the parameter (No. 5002#1).)
N1 X50.0 Z100.0 T0202 ; Tool selection number (specified tool geometry offset number 02)
N2 Z200.0 ;
N3 X100.0 Z250.0 T0000 ; Cancels offset

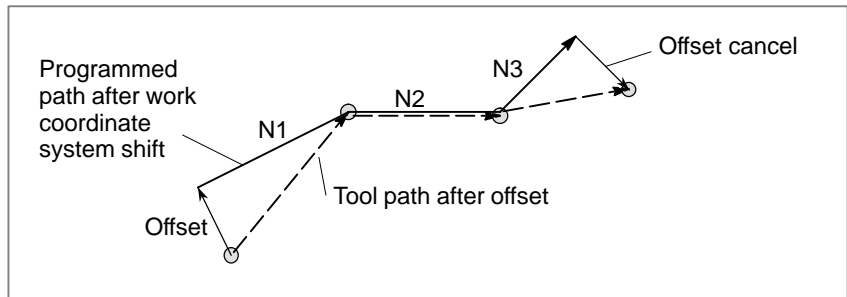

14.1.6 G53, G28, G30, and G30.1 Commands When Tool Position Offset is Applied

This section describes the following operations when tool position offset is applied: G53, G28, G30, and G30.1 commands, manual reference position return, and the canceling of tool position offset with a T00 command.

Explanations

- **Reference position return (G28) and G53 command when tool position offset is applied**

Executing reference position return (G28) or a G53 command when tool position offset is applied does not cancel the tool position offset vector. The absolute position display is as follows, however, according to the setting of bit 4 (LGT) of parameter No. 5002.

LGT = 0 (Tool geometry compensation is based on shift of the coordinate system.)

		Tool position offset (without option)	Tool geometry compensation	Tool wear compensation
Absolute position coordinate display	Block for reference position return or G53 command	The vector is not reflected. The coordinates are displayed as if the offset had been temporarily canceled.	The shift is reflected. Coordinates shifted according to the tool geometry compensation are displayed.	The vector is not reflected. The coordinates are displayed as if the offset had been temporarily canceled.
	Next block	The vector is reflected.	Coordinates shifted according to the tool geometry compensation are displayed.	The vector is reflected.

LGT = 1 (Tool geometry compensation is based on tool movement.)

		Tool position offset (without option)	Tool geometry compensation	Tool wear compensation
Absolute position coordinate display	Block for reference position return or G53 command	The vector is not reflected. The coordinates are displayed as if the offset had been temporarily canceled.	The vector is not reflected. The coordinates are displayed as if the offset had been temporarily canceled.	The vector is not reflected. The coordinates are displayed as if the offset had been temporarily canceled.
	Next block	The vector is reflected.	The vector is reflected.	The vector is reflected.

NOTE

Bit 6 (DAL) of parameter No. 3104 is set to 0 (the actual positions to which the tool position offset is applied are displayed in the absolute position display).

● **Manual reference position return when tool position offset is applied**

Executing manual reference position return when tool position offset is applied does not cancel the tool position offset vector. The absolute position display is as follows, however, according to the setting of bit 4 (LGT) of parameter No. 5002.

LGT = 0 (Tool geometry compensation is based on shift of the coordinate system.)

		Tool position offset (without option)	Tool geometry compensation	Tool wear compensation
Absolute position coordinate display	Upon manual reference position return	The vector is not reflected. The coordinates are displayed as if the offset had been temporarily canceled.	The shift is reflected. Coordinates shifted according to tool geometry compensation are displayed.	The vector is not reflected. The coordinates are displayed as if the offset had been temporarily canceled.
	Next block	The vector is reflected.	Coordinates shifted according to tool geometry compensation are displayed.	The vector is reflected.

LGT = 1 (Tool geometry compensation is based on tool movement.)

		Tool position offset (without option)	Tool geometry compensation	Tool wear compensation
Absolute position coordinate display	Upon manual reference position return	The vector is not reflected. The coordinates are displayed as if the offset had been temporarily canceled.	The vector is not reflected. The coordinates are displayed as if the offset had been temporarily canceled.	The vector is not reflected. The coordinates are displayed as if the offset had been temporarily canceled.
	Next block	The vector is reflected.	The vector is reflected.	The vector is reflected.

NOTE

Bit 6 (DAL) of parameter No. 3104 is set to 0 (the actual positions to which the tool position offset is applied are displayed in the absolute position display).

● **Canceling tool position offset with T00**

Whether specifying T00 alone, while tool position offset is applied, cancels the offset depends on the settings of the following parameters:

When the tool geometry/wear compensation option is selected

LGN = 0

LGN (No.5002#1)	LGT (No.5002#4)	LGC (No.5002#5)	
The geometry offset number is: 0: Same as the wear offset number 1: Same as the tool selection number	Geometry compensation is applied: 0: Based on shift of the coordinate system 1: Based on movement of the tool	The geometry offset is: 0: Not canceled with T00 1: Canceled with T00	Result
LGT=0	LGT=0	LGC=0 LGC=1	Not canceled Canceled
		LWM (No.5002#6) Tool position offset is applied: 0: By means of T code 1: By means of movement along axis	
	LGT=1	LWM=0 LWM=1	Canceled Not canceled

NOTE

- 1 When LGT=0, LWM is unrelated.
- 2 When LGT=1, LGC is unrelated, even when LGN = 0.

LGN = 1

LGN (No.5002#1)	LGT (No.5002#4)	LGC (No.5002#5)	
The geometry offset number is: 0: Same as the wear offset number 1: Same as the tool selection number	Geometry compensation is applied: 0: Based on shift of the coordinate system 1: Based on movement of the tool	The geometry offset is: 0: Not canceled with T00 1: Canceled with T00	Result
LGT=0	LGT=0	LGC is unrelated.	Canceled
		LWM (No.5002#6) Tool position offset is applied: 0: By means of T code 1: By means of movement along axis	
	LGT=1	LWM=0 LWM=1	Canceled Not canceled

NOTE

- 1 When LGT = 0, LWM is unrelated.
- 2 When LGT = 1, LGC is unrelated.

When the tool geometry/wear compensation option is not selected

LGN (No.5002#1)	LGT (No.5002#4)	LGC (No.5002#5)	
The geometry offset number is: 0: Same as the wear offset number 1: Same as the tool selection number	Geometry compensation is applied: 0: Based on shift of the coordinate system 1: Based on movement of the tool	The geometry offset is: 0: Not canceled with T00 1: Canceled with T00	Result
LGN is unrelated. The tool position offset number always uses the low-order digits.	LGT is unrelated. Tool position offset is always applied based on the movement of the tool.	LGC is unrelated.	
		LWM (No.5002#6)	
		Tool position offset is applied: 0: By means of T code 1: By means of movement along axis	
		LWM=0 LWM=1	

14.2 OVERVIEW OF TOOL NOSE RADIUS COMPENSATION

It is difficult to produce the compensation necessary to form accurate parts when using only the tool offset function due to tool nose roundness in taper cutting or circular cutting. The tool nose radius compensation function compensates automatically for the above errors.

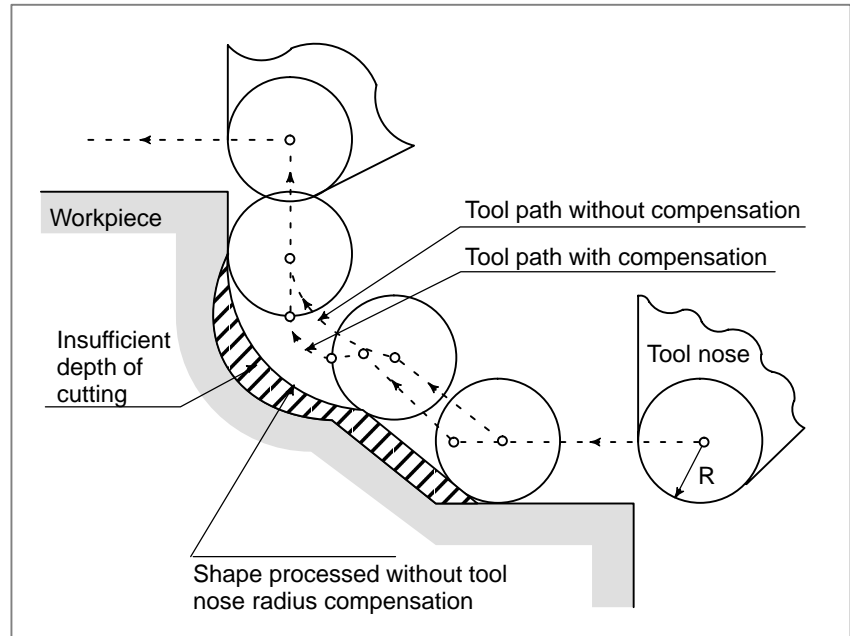

Fig 14.2 Tool path of tool nose radius compensation

14.2.1 Imaginary Tool Nose

The tool nose at position A in following figure does not actually exist. The imaginary tool nose is required because it is usually more difficult to set the actual tool nose radius center to the start position than the imaginary tool nose (Note).

Also when imaginary tool nose is used, the tool nose radius need not be considered in programming.

The position relationship when the tool is set to the start position is shown in the following figure.

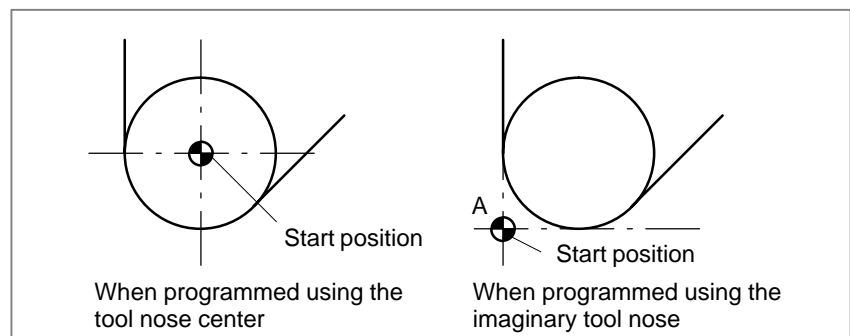

Fig. 14.2.1 (a) Tool nose radius center and imaginary tool nose

CAUTION

In a machine with reference positions, a standard position like the turret center can be placed over the start position. The distance from this standard position to the nose radius center or the imaginary tool nose is set as the tool offset value.

Setting the distance from the standard position to the tool nose radius center as the offset value is the same as placing the tool nose radius center over the start position, while setting the distance from the standard position to the imaginary tool nose is the same as placing the imaginary tool nose over the standard position. To set the offset value, it is usually easier to measure the distance from the standard position to the imaginary tool nose than from the standard position to the tool nose radius center.

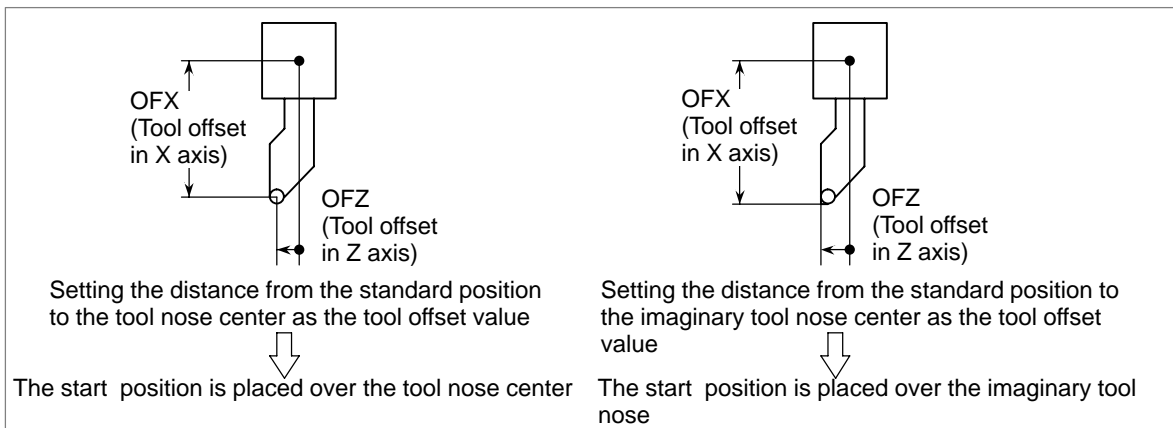

Fig. 14.2.1 (b) Tool offset value when the turret center is placed over the start position

Unless tool nose radius compensation is performed, the tool nose center path is the same as the programmed path.

If tool nose radius compensation is used, accurate cutting will be performed.

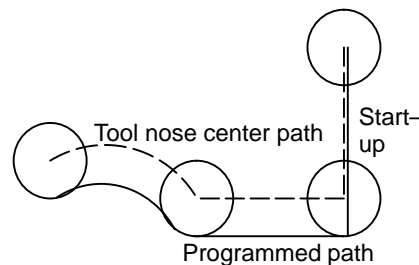
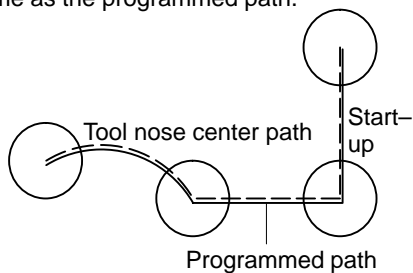

Fig. 14.2.1 (c) Tool path when programming using the tool nose center

Without tool nose radius compensation, the imaginary tool nose path is the same as the programmed path.

With tool nose radius compensation, accurate cutting will be performed.

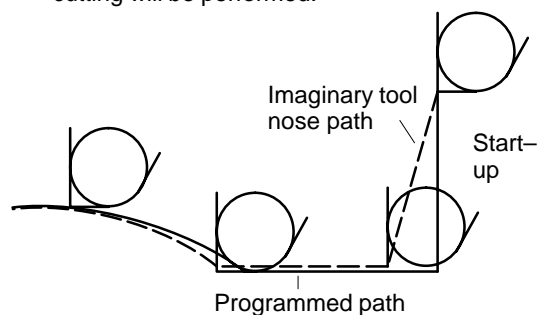
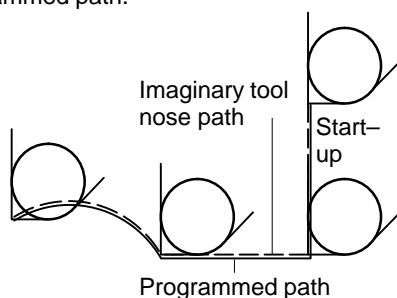

Fig. 14.2.1 (d) Tool path when programming using the imaginary tool nose

14.2.2 Direction of Imaginary Tool Nose

The direction of the imaginary tool nose viewed from the tool nose center is determined by the direction of the tool during cutting, so it must be set in advance as well as offset values.

The direction of the imaginary tool nose can be selected from the eight specifications shown in the Fig. 14.2.2 below together with their corresponding codes.

This Fig 14.2.2 illustrates the relation between the tool and the start position. The following apply when the tool geometry offset and tool wear offset option are selected.

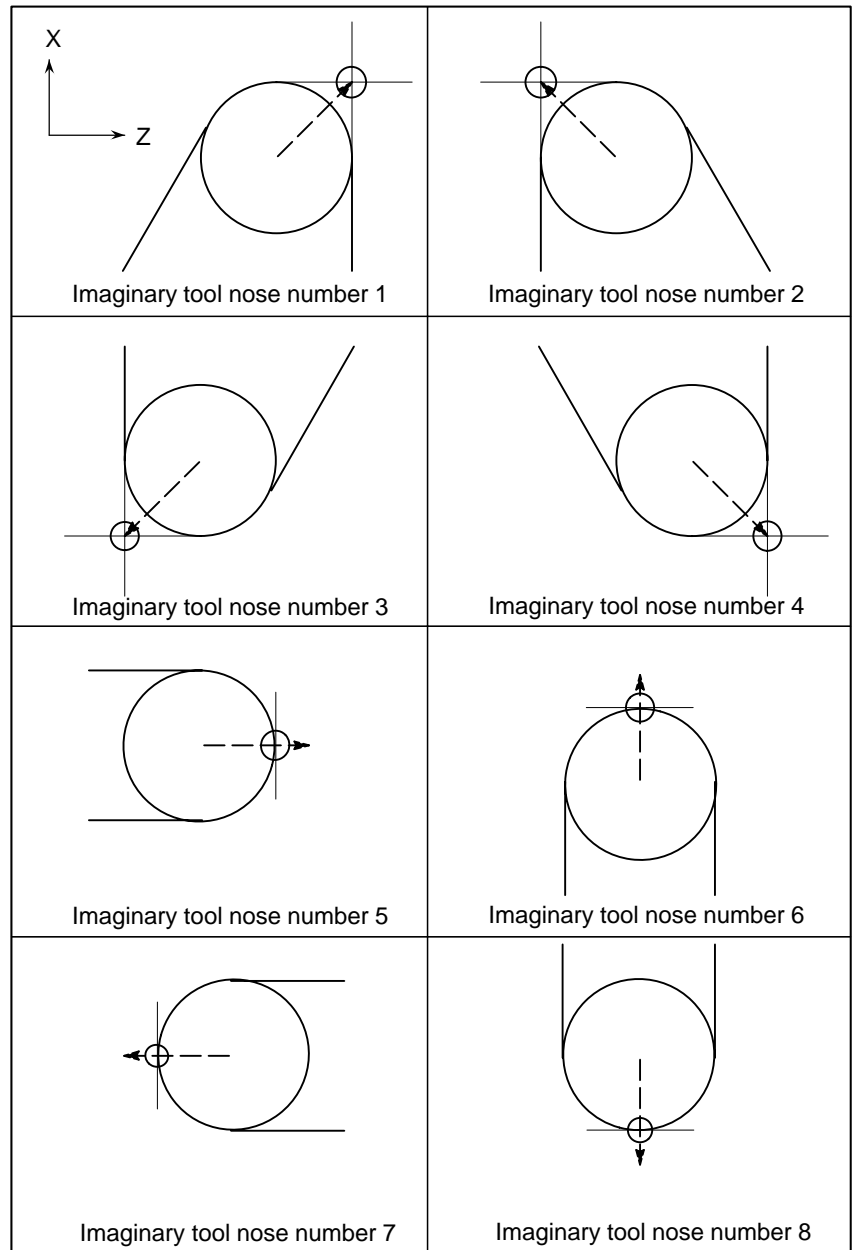
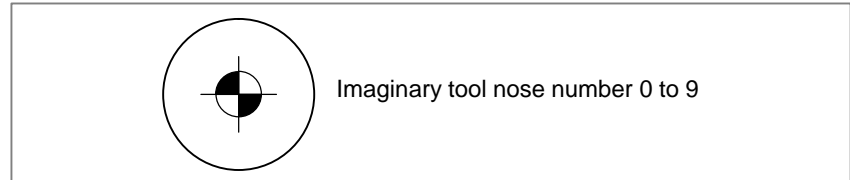

Fig. 14.2.2 Direction of imaginary tool nose

Imaginary tool nose numbers 0 and 9 are used when the tool nose center coincides with the start position. Set imaginary tool nose number to address OFT for each offset number.

Bit 7 (WNP) of parameter No. 5002 is used to determine whether the tool geometry offset number or the tool wear offset number specifies the direction of the virtual tool nose for tool nose radius compensation.



Limitations

- **Plane selection**

Virtual tool nose directions 1 to 8 can be used only in the G18 (Z-X) plane. For virtual tool nose 0 or 9, compensation is applied in both the G17 and G19 planes.

**14.2.3
Offset Number and
Offset Value**

Explanations

- **Offset number and offset value**

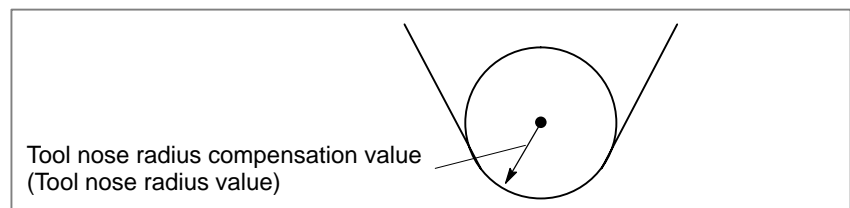

This value is set from the MDI according to the offset number. When the options of tool geometry compensation and tool wear compensation are selected, offset values become as follows :

Table 14.2.3 (a) Offset number and offset value

Offset number	OFX (Offset value on X axis)	OFZ (Offset value on Z axis)	OFR (Tool nose radius compensation value)	OFT (Direction of imaginary tool nose)	OFY (Offset value on Y axis)
01	0.040	0.020	0.20	1	0.030
02	0.060	0.030	0.25	2	0.040
⋮	⋮	⋮	⋮	⋮	⋮
98	0.050	0.015	0.12	6	0.025
99	0.030	0.025	0.24	3	0.035

When the options of tool geometry compensation and tool wear compensation are selected, the offset values become as follows :

Table 14.2.3 (b) Tool geometry offset

Geometry offset number	OFGX (X-axis geometry offset amount)	OFGZ (Z-axis geometry offset amount)	OFGR (Tool nose radius geometry offset value)	OFT (Imaginary tool nose direction)	OFGY (Y-axis geometry offset amount)
G01	10.040	50.020	0	1	70.020
G02	20.060	30.030	0	2	90.030
G03	0	0	0.20	6	0
G04	:	:	:	:	:
G05	:	:	:	:	:
:	:	:	:	:	:

Table 14.2.3 (c) Tool wear offset

Wear offset number	OFGX (X-axis wear offset amount)	OFGZ (Z-axis wear offset amount)	OFGR (Tool nose radius wear offset value)	OFT (Imaginary tool nose direction)	OFGY (Y-axis wear offset amount)
W01	0.040	0.020	0	1	0.010
W02	0.060	0.030	0	2	0.020
W03	0	0	0.20	6	0
W04	:	:	:	:	:
W05	:	:	:	:	:
:	:	:	:	:	:

- **Tool nose radius compensation**

In this case, the tool nose radius compensation value is the sum of the geometry or the wear offset value.

$$\text{OFR} = \text{OFGR} + \text{OFWR}$$

- **Imaginary tool nose direction**

The imaginary tool nose direction may be set for either the geometry offset or the wear offset.

However, the last designated direction later is effective.

- **Command of offset value**

A offset number is specified with the same T code as that used for tool offset. For details, see Subsec. II-14.1.2.

NOTE

When the geometry offset number is made common to the tool selection by the parameter LGT(No.5002#1) setting and a T code for which the geometry offset and wear offset number differ from each other is designated, the imaginary tool nose direction specified by the geometry offset number is valid.

Example) T0102
 $\text{OFR} = \text{RFGR}_{01} + \text{OFWR}_{02}$
 $\text{OFT} = \text{OFT}_{01}$

● **Setting range of offset value**

The range of the offset value is as follows :

Increment system	metric system	Inch system
IS-B	0 to ± 999.999 mm	0 to ± 99.9999 inch
IS-C	0 to ± 999.9999 mm	0 to ± 99.99999 inch

The offset value corresponding to the offset number 0 is always 0. No offset value can be set to offset number 0.

14.2.4 Work Position and Move Command

In tool nose radius compensation, the position of the workpiece with respect to the tool must be specified.

G code	Workpiece position	Tool path
G40	(Cancel)	Moving along the programmed path
G41	Right side	Moving on the left side the programmed path
G42	Left side	Moving on the right side the programmed path

The tool is offset to the opposite side of the workpiece.

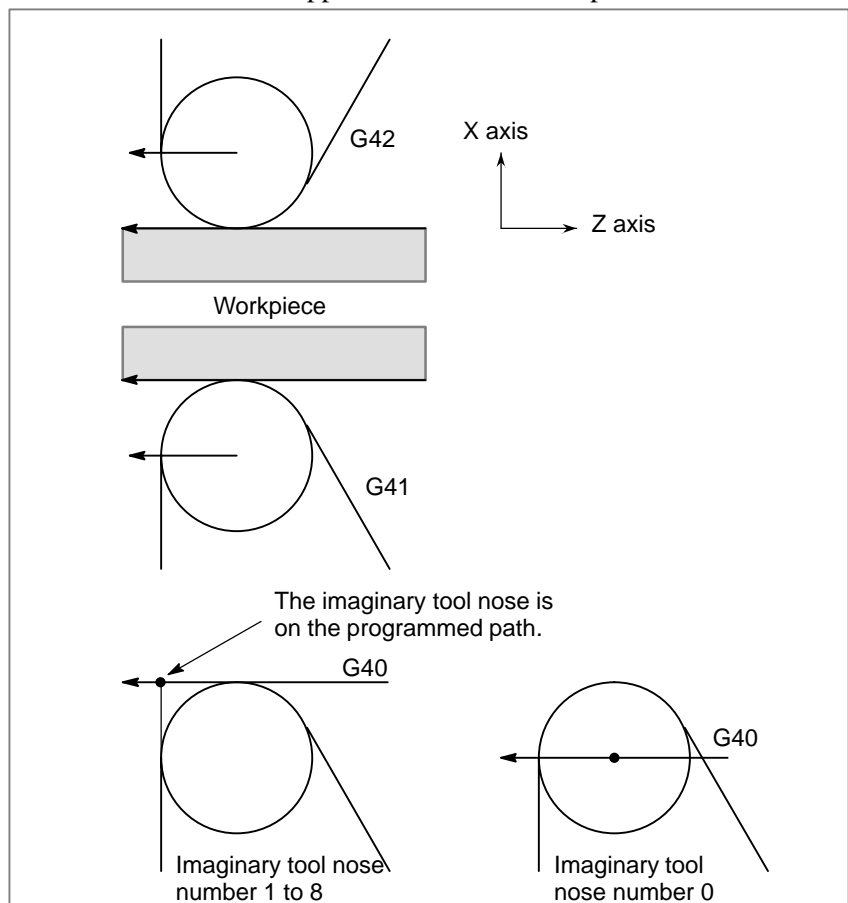

The workpiece position can be changed by setting the coordinate system as shown below.

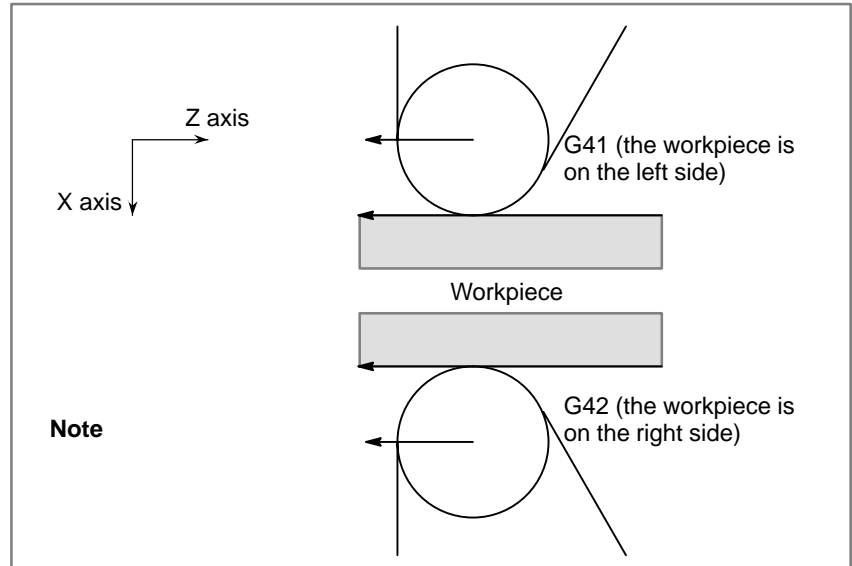

NOTE
If the tool nose radius compensation value is negative, the workpiece position is changed.

G40, G41, and, G42 are modal.

Don't specify G41 while in the G41 mode. If you do, compensation will not work properly.

Don't specify G42 while in the G42 mode for the same reason.

G41 or G42 mode blocks in which G41 or G42 are not specified are expressed by (G41) or (G42) respectively.

- **Tool movement when the workpiece position does not change**

When the tool is moving, the tool nose maintains contact with the workpiece.

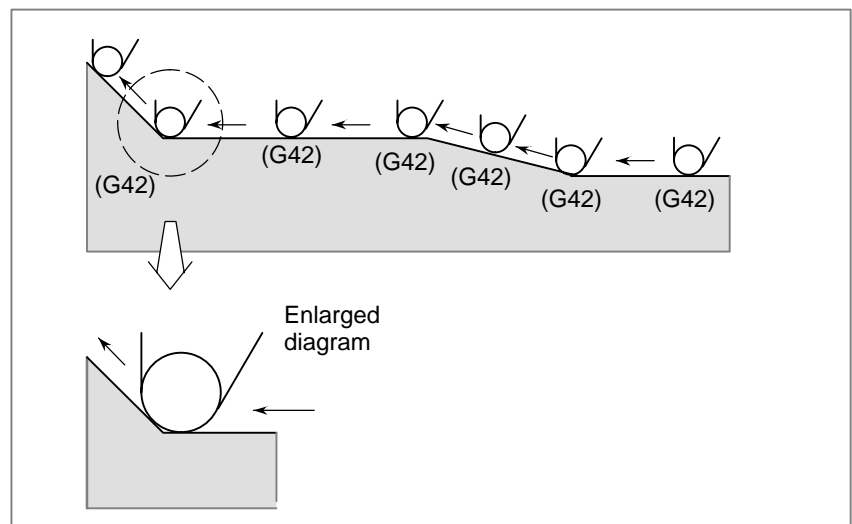

• **Tool movement when the workpiece position changes**

The workpiece position against the toll changes at the corner of the programmed path as shown in the following figure.

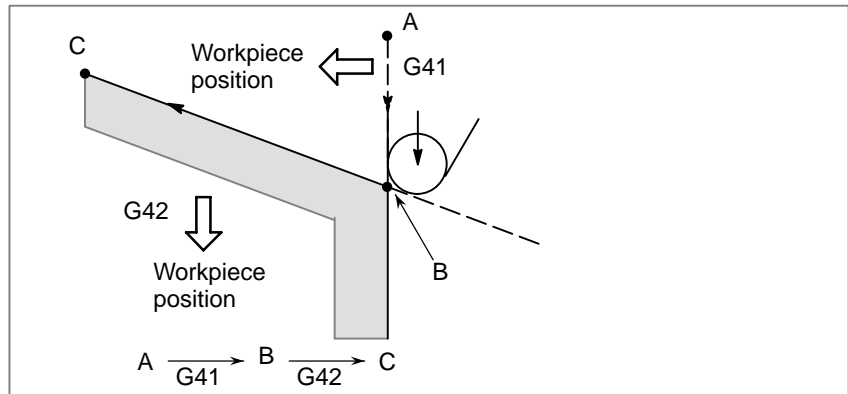

Although the workpiece does not exist on the right side of the programmed path in the above case, the existence of the workpiece is assumed in the movement from A to B. The workpiece position must not be changed in the block next to the start-up block. In the above example, if the block specifying motion from A to B were the start-up block, the tool path would not be the same as the one shown.

• **Start-up**

The block in which the mode changes to G41 or G42 from G40 is called the start-up block.

```
G40 _ ;
G41 _ ; (Start-up block)
```

Transient tool movements for offset are performed in the start-up block. In the block after the start-up block, the tool nose center is positioned vertically to the programmed path of that block at the start position.

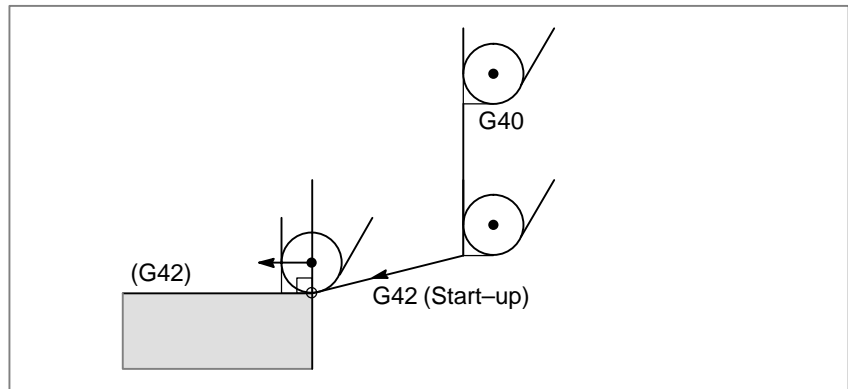

- **Offset cancel**

The block in which the mode changes to G40 from G41 or G42 is called the offset cancel block.

G41 _ ;

G40 _ ; (Offset cancel block)

The tool nose center moves to a position vertical to the programmed path in the block before the cancel block. The tool is positioned at the end position in the offset cancel block (G40) as shown below.

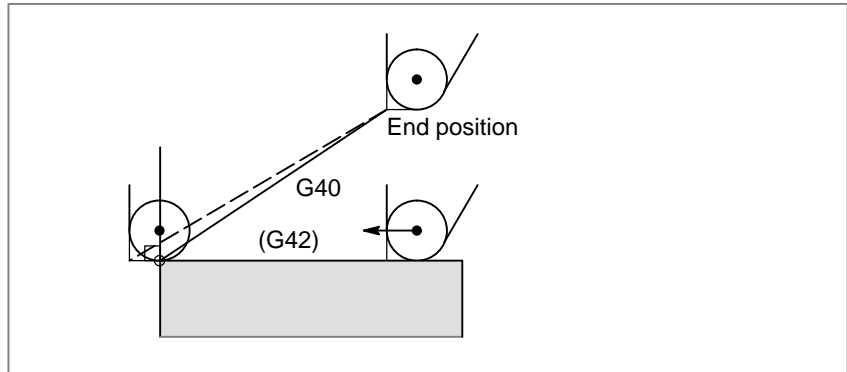

- **Specification of G41/G42 in G41/G42 mode**

When is specified again in G41/G42 mode, the tool nose center is positioned vertical to the programmed path of the preceding block at the end position of the preceding block.

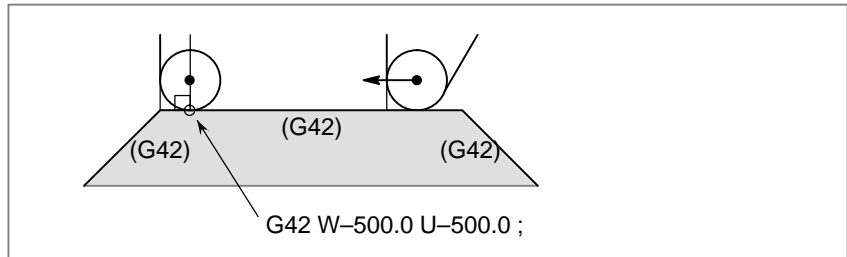

In the block that first specifies G41/G42, the above positioning of the tool nose center is not performed.

- **Tool movement when the moving direction of the tool in a block which includes a G40 command is different from the direction of the workpiece**

When you wish to retract the tool in the direction specified by X(U) and Z(W) cancelling the tool nose radius compensation at the end of machining the first block in the figure below, specify the following :

G40 X(U) _ Z(W) _ I _ K _ ;

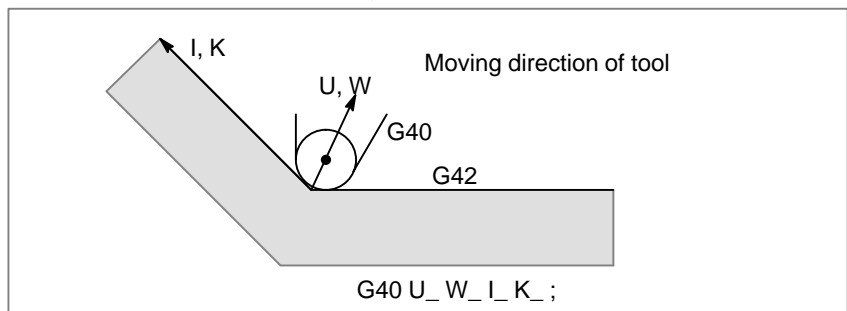

The workpiece position specified by addresses I and K is the same as that in the preceding block. If I and/or K is specified with G40 in the cancel mode, the I and/or K is ignored.

G40 X_ Z_ I_ K_ ;	Tool nose radius compensation
G40 G02 X_ Z_ I_ K_ ;	Circular interpolation

G40 G01 X_ Z_ ;

G40 G01 X_ Z_ I_ K_ ; Offset cancel mode (I and k are ineffective.)

The numeral s followed I and K should always be specified as radius values.

Examples

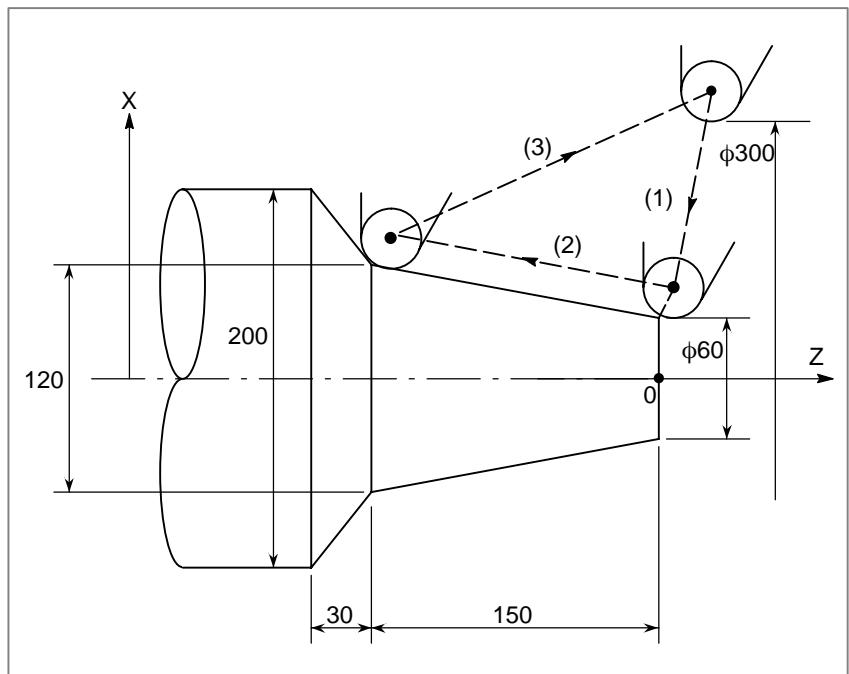

(G40 mode)

1.G42 G00 X60.0 ;

2.G01 X120.0 W-150.0 F10 ;

3.G40 G00 X300.0 W150.0 I40.0 K-30.0 ;

14.2.5

Notes on Tool Nose Radius Compensation

Explanations

- Tool movement when two or more blocks without a move command should not be programmed consecutively

- | | |
|---------------------------------|-----------------------|
| 1.M05 ; | M code output |
| 2.S210 ; | S code output |
| 3.G04 X1000 ; | Dwell |
| 4.G01 U0 ; | Feed distance of zero |
| 5.G98 ; | G code only |
| 6.G10 P01 X10.0 Z20.0 R0.5 Q2 ; | Offset change |

If two or more of the above blocks are specified consecutively, the tool nose center comes to a position vertical to the programmed path of the preceding block at the end of the preceding block. However, if the no movement commands is 4 above, the above tool motion is attained only with one block.

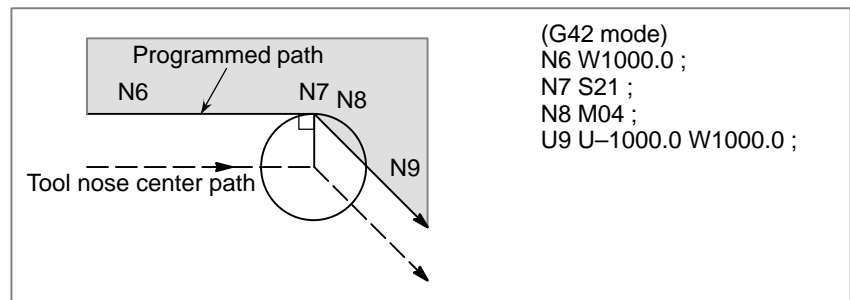

- Tool nose radius compensation with G90 or G94

Tool nose radius compensation with G90 (outer diameter/internal diameter cutting cycle) or G94 (end face turning cycle) is as follows, :

1. Motion for imaginary tool nose numbers

For each path in the cycle, the tool nose center path is generally parallel to the programmed path.

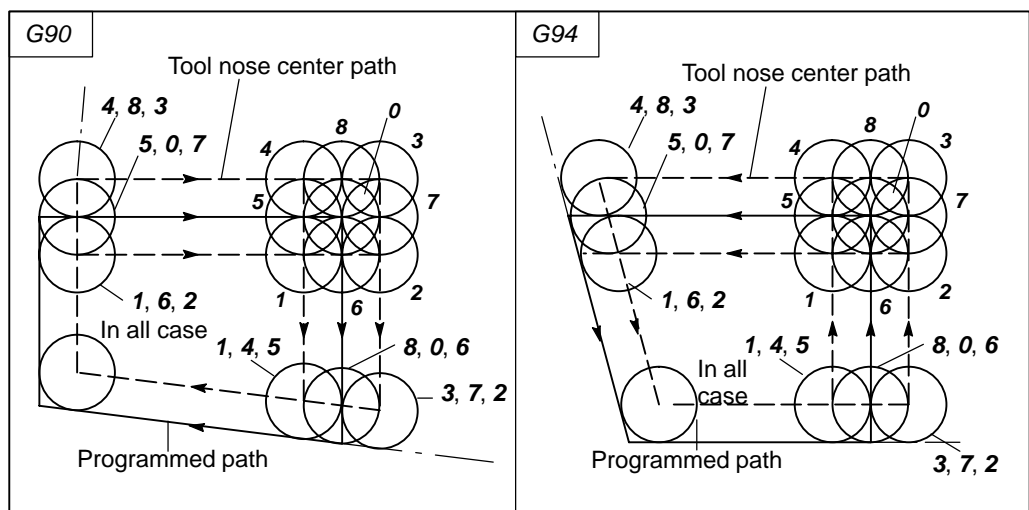

2. Direction of the offset

The offset direction is indicated in the figure below regardless of the G41/G42 mode.

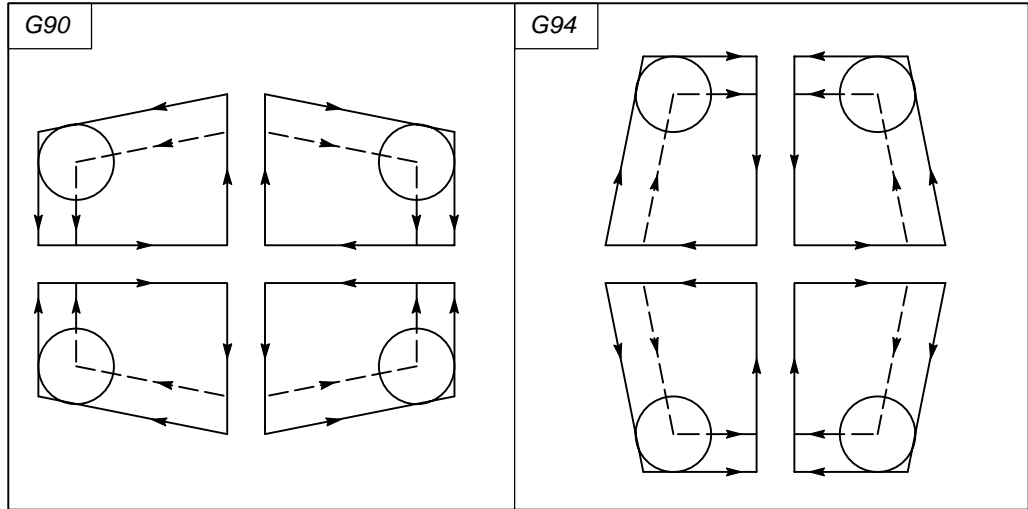

• **Tool nose radius compensation with G71 to G76 or G78**

When one of following cycles is specified, the cycle deviates by a tool nose radius compensation vector. During the cycle, no intersection calculation is performed.

- G71 (Stock removal in turning or traverse grinding cycle)
- G72 (Stock removal in facing or traverse direct constant-dimension grinding cycle)
- G73 (Pattern repeating or Oscillation grinding cycle)
- G74 (End face peck drilling)
- G75 (Outer diameter/internal diameter drilling)
- G76 (Multiple threading cycle)
- G78 (Threading cycle)

• **Tool nose radius compensation when chamfering is performed**

Movement after after compensation is shown below.

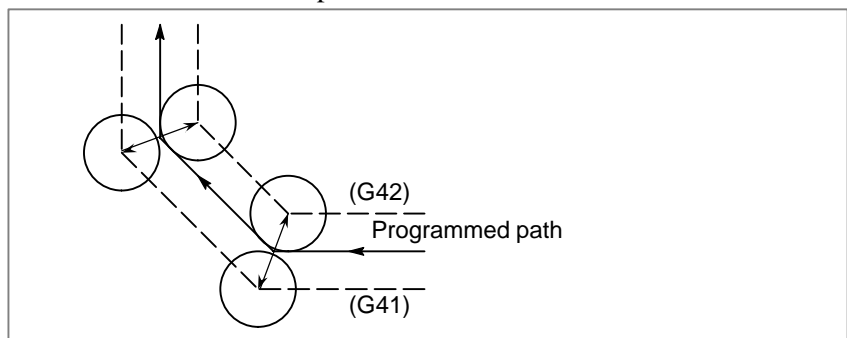

• **Tool nose radius compensation when a corner arc is inserted**

Movement after compensation is shown below.

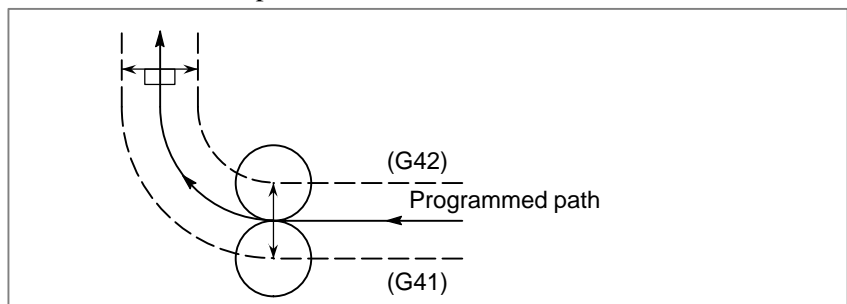

- **Tool nose radius compensation when the block is specified from the MDI**

In this case, tool nose radius compensation is not performed.

14.3 DETAILS OF TOOL NOSE RADIUS COMPENSATION

This section provides a detailed explanation of the movement of the tool for tool nose radius compensation outlined in Section 14.2.

This section consists of the following subsections:

14.3.1 General

14.3.2 Tool Movement in Start-up

14.3.3 Tool Movement in Offset Mode

14.3.4 Tool Movement in Offset Mode Cancel

14.3.5 Interference Check

14.3.6 Overcutting by Tool Nose Radius Compensation

14.3.7 Correction in Chamfering and Corner Arcs

14.3.8 Input Command from MDI

14.3.9 General Precautions for Offset Operations

14.3.10 G53, G28, G30, and G30.1 Commands in Tool-tip Radius Compensation Mode

14.3.1 General

- **Tool nose radius center offset vector**

The tool nose radius center offset vector is a two dimensional vector equal to the offset value specified in a T code, and the is calculated in the CNC. Its dimension changes block by block according to tool movement.

This offset vector (simply called vector herein after) is internally crated by the control unit as required for proper offsetting and to calculate a tool path with exact offset (by tool nose radius) from the programmed path.

This vector is deleted by resetting.

The vector always accompanies the tool as the tool advances.

Proper understanding of vector is essential to accurate programming.

Read the description below on how vectors are created carefully.

- **G40, G41, G42**

G40, G41 or G42 is used to delete or generate vectors.

These codes are used together with G00, G01, G02, G03 or G33 to specify a mode for tool motion (Offsetting).

G code	Function	Workpiece position
G40	Tool nose radius compensation cancel	Neither
G41	Left offset along tool path	Right
G42	Right offset along tool path	Left

G41 and G42 specify an off mode, while G40 specifies cancellation of the offset.

- **Cancel mode**

The system enters the cancel mode immediately after the power is turned on, when the RESET button on the MDI is pushed or a program is forced to end by executing M02 or M30. (the system may not enter the cancel mode depending on the machine tool.) In the cancel mode, the vector is set to zero, and the path of the center of tool nose coincides with the programmed, path. A program must end in cancel mode. If it ends in the offset mode, the tool cannot be positioned at the end point, and the tool stops at a location the vector length away from the end point.

• Start-up

When a block which satisfies all the following conditions is executed in cancel mode, the system enters the offset mode. Control during this operation is called start-up.

- G41 or G42 is contained in the block, or has been specified to set the system enters the offset mode. Control during this operation is called start-up.
- The offset number for tool nose radius compensation is not 00.
- X or Z moves is specified in the block and the move distance is not zero.

A circular command (G02 or G03) is not allowed in start-up.

If specified, P/S alarm (PS34) will occur. Two blocks are read in during start-up. The first block is executed, and the second block is entered into the tool nose radius compensation buffer. In the single block mode, two blocks are read and the first block is executed, then the machine stops. In subsequent operations, two blocks are read in advance, so the CNC has the block currently being executed, and the next two blocks.

• Inner side and outer side

When an angle of intersection created by tool paths specified with move commands for two blocks is over 180° , it is referred to as "inner side." When the angle is between 0° and 180° , it is referred to as "outer side."

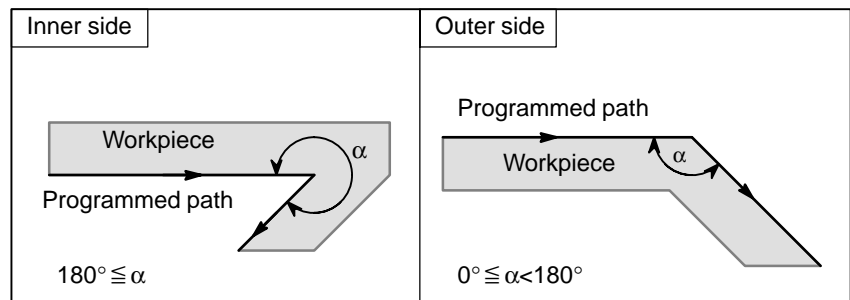

• Meaning of symbols

The following symbols are used in subsequent figures:

- *S* indicates a position at which a single block is executed once.
- *SS* indicates a position at which a single block is executed twice.
- *SSS* indicates a position at which a single block is executed three times.
- *L* indicates that the tool moves along a straight line.
- *C* indicates that the tool moves along an arc.
- *r* indicates the tool nose radius compensation value.
- An intersection is a position at which the programmed paths of two blocks intersect with each other after they are shifted by *r*.
- \circ indicates the center of the tool nose radius.

14.3.2 Tool Movement in Start-up

When the offset cancel mode is changed to offset mode, the tool moves as illustrated below (start-up):

Explanations

- Tool movement around an inner side of a corner ($180^\circ \cong \alpha$)

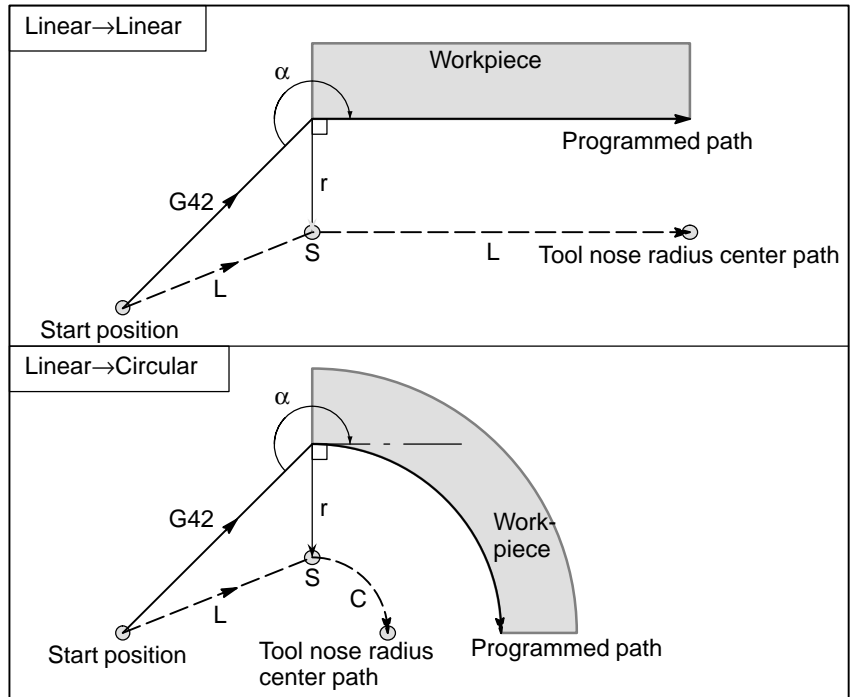

- Tool movement around the outside of a corner at an obtuse angle ($90^\circ \cong \alpha < 180^\circ$)

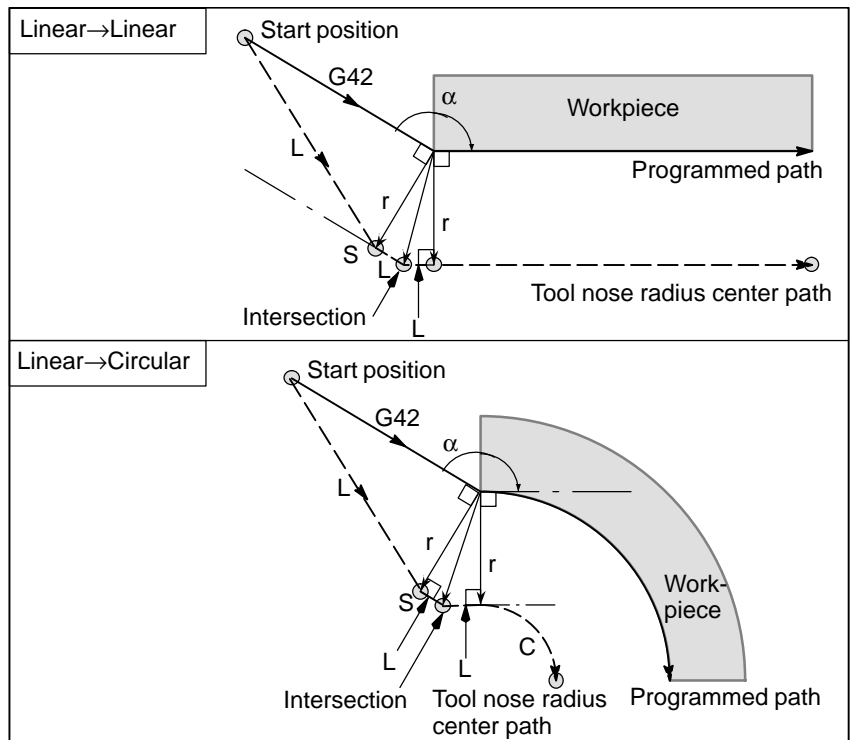

- Tool movement around the outside of an acute angle ($\alpha < 90^\circ$)

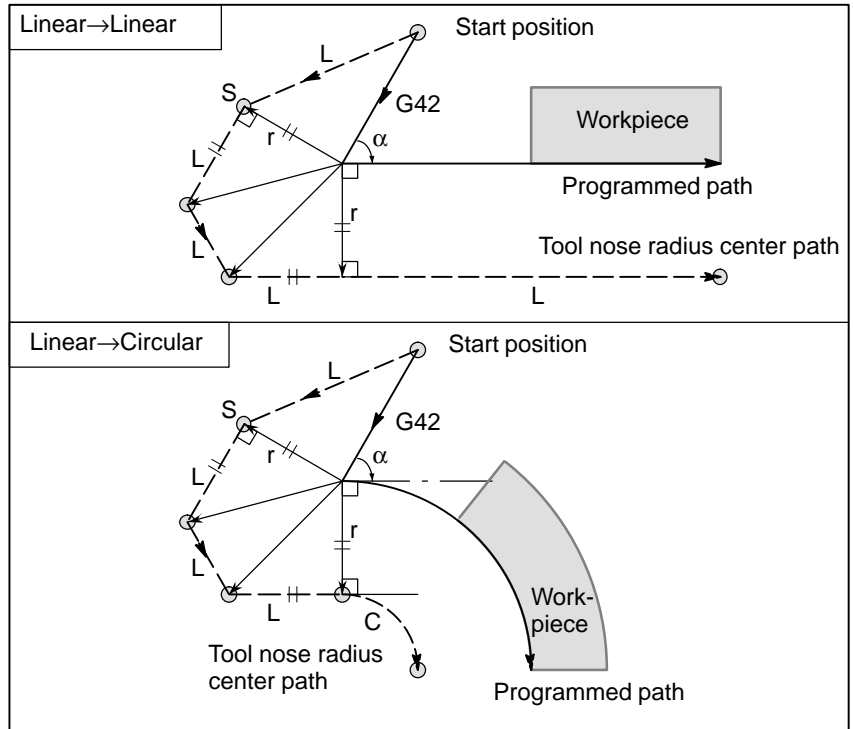

- Tool movement around the outside linear→linear at an acute angle less than 1 degree ($\alpha < 1^\circ$)

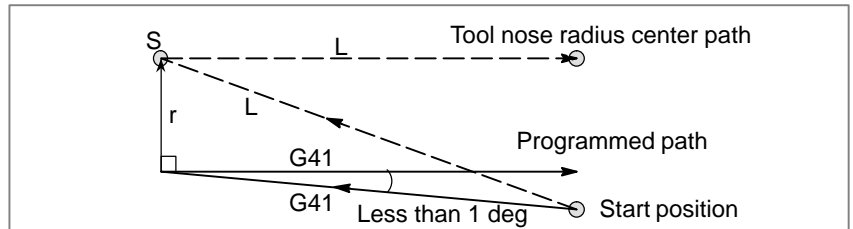

- A block without tool movement specified at start-up

If the command is specified at start-up, the offset vector is not created.

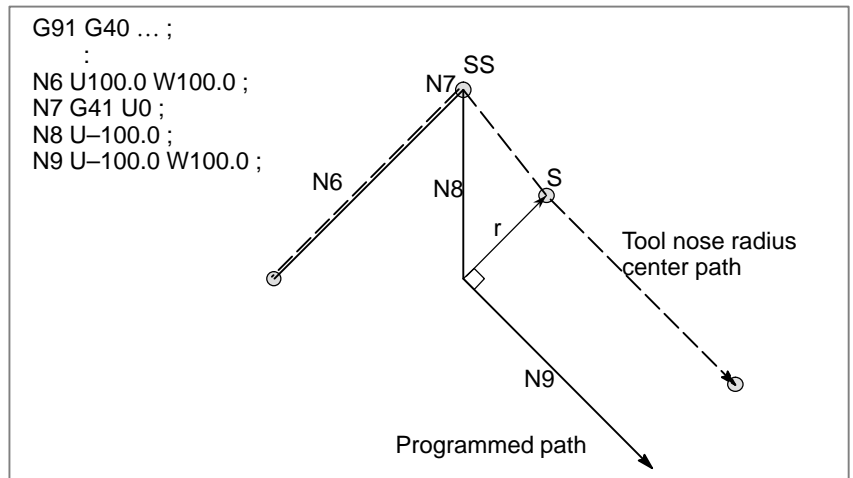

NOTE

For the definition of blocks that do not move the tool, see Subsec. II-14.3.3.

14.3.3 Tool Movement in Offset Mode

In the offset mode, the tool moves as illustrated below:

Explanations

- Tool movement around the inside of a corner ($180^\circ \cong \alpha$)

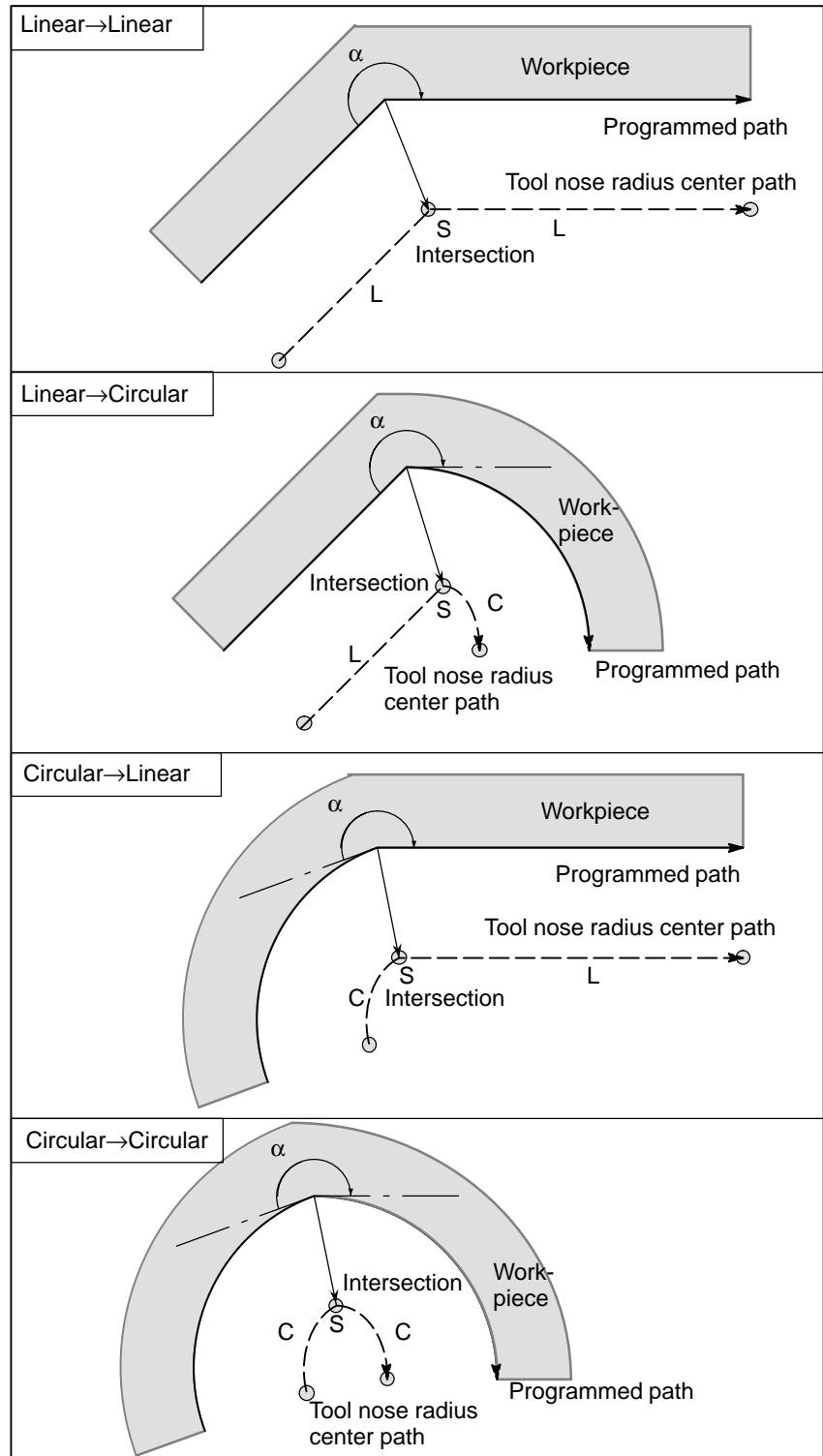

- Tool movement around the inside ($\alpha < 1^\circ$) with an abnormally long vector, linear \rightarrow linear

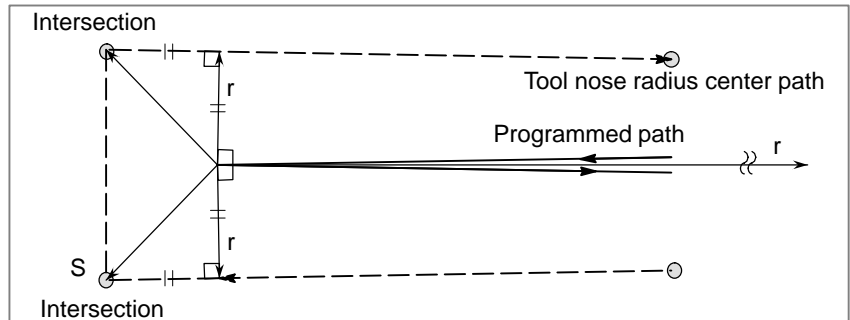

Also in case of arc to straight line, straight line to arc and arc to arc, the reader should infer in the same procedure.

- Tool movement around the outside corner at an obtuse angle ($90^\circ \leq \alpha < 180^\circ$)

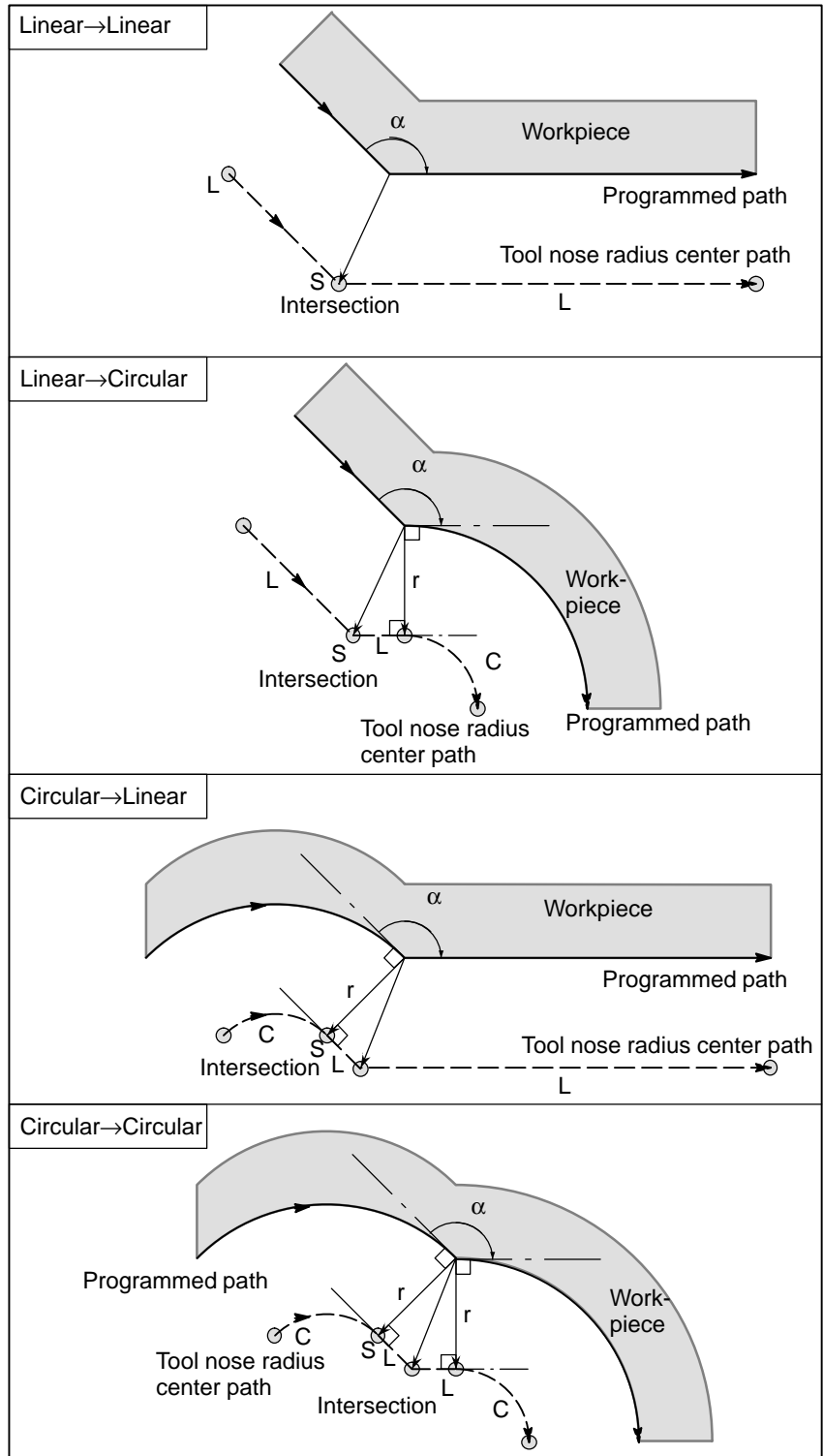

- Tool movement around the outside corner at an acute angle ($\alpha < 90^\circ$)

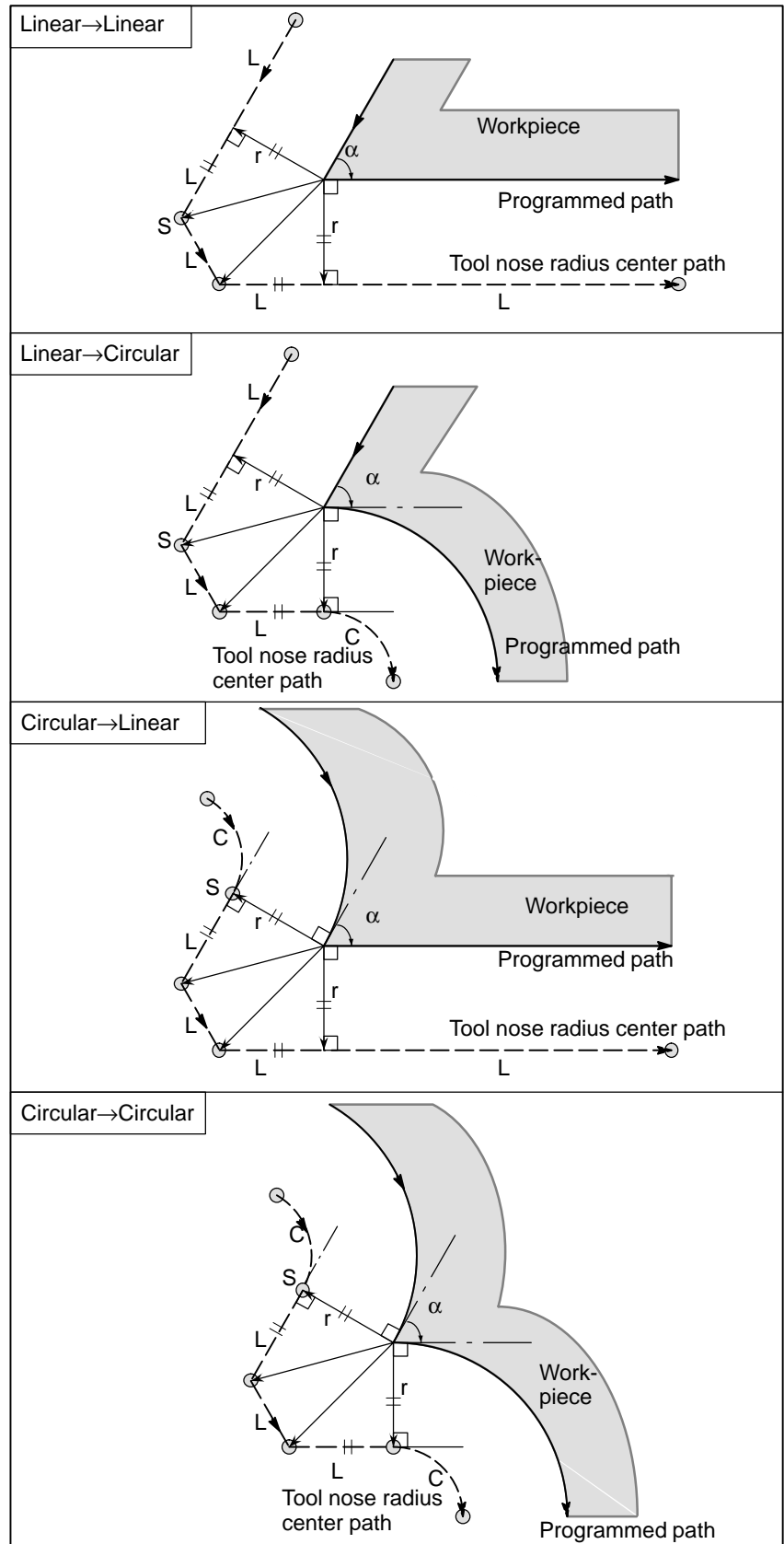

- **When it is exceptional**

- End position for the arc is not on the arc

If the end of a line leading to an arc is programmed as the end of the arc by mistake as illustrated below, the system assumes that tool nose radius compensation has been executed with respect to an imaginary circle that has the same center as the arc and passes the specified end position. Based on this assumption, the system creates a vector and carries out compensation. The resulting tool nose radius center path is different from that created by applying tool nose radius compensation to the programmed path in which the line leading to the arc is considered straight.

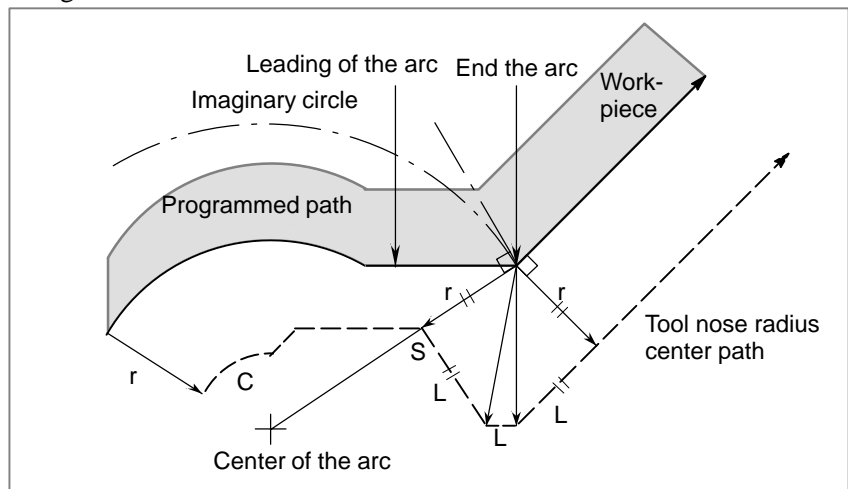

The same description applies to tool movement between two circular paths.

- There is no inner intersection

If the tool nose radius compensation value is sufficiently small, the two circular Tool nose radius center paths made after compensation intersect at a position (P). Intersection P may not occur if an excessively large value is specified for tool nose radius compensation. When this is predicted, P/S alarm (No.33) occurs at the end of the previous block and the tool is stopped. In the example shown below, Tool nose radius center paths along arcs A and B intersect at P when a sufficiently small value is specified for tool nose radius compensation. If an excessively large value is specified, this intersection does not occur.

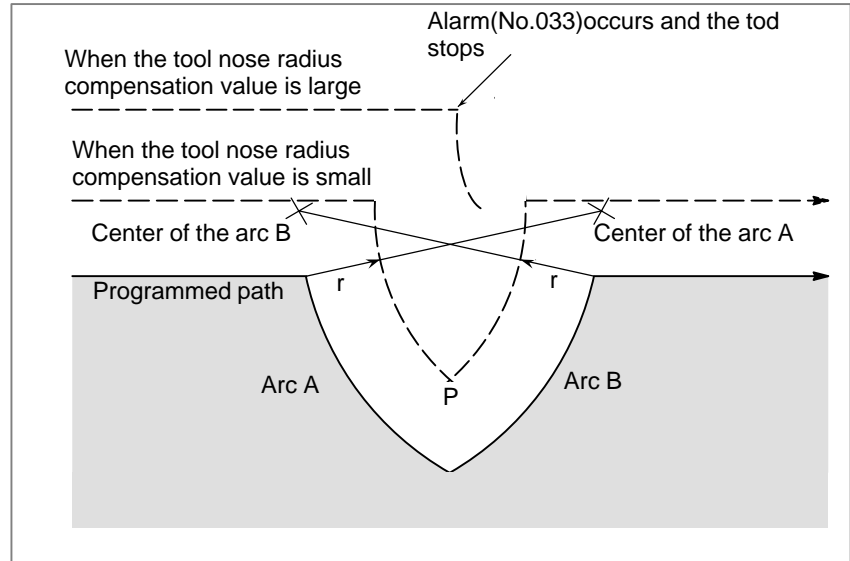

- The center of the arc is identical with the start position or the end position

If the center of the arc is identical with the start position or end point, P/S alarm (No. 038) is displayed, and the tool will stop at the end position of the preceding block.

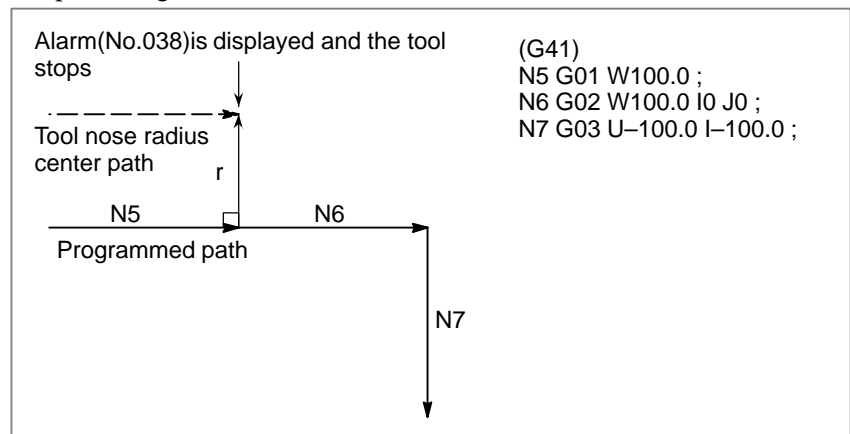

- **Change in the offset direction in the offset mode**

The offset direction is decided by G codes (G41 and G42) for tool nose radius and the sign of tool nose radius compensation value as follows.

G code	Sign of offset value	
	+	-
G41	Left side offset	Right side offset
G42	Right side offset	Left side offset

The offset direction can be changed in the offset mode. If the offset direction is changed in a block, a vector is generated at the intersection of the tool nose radius center path of that block and the tool nose radius center path of a preceding block. However, the change is not available in the start-up block and the block following it.

- Tool nose radius center path with an intersection

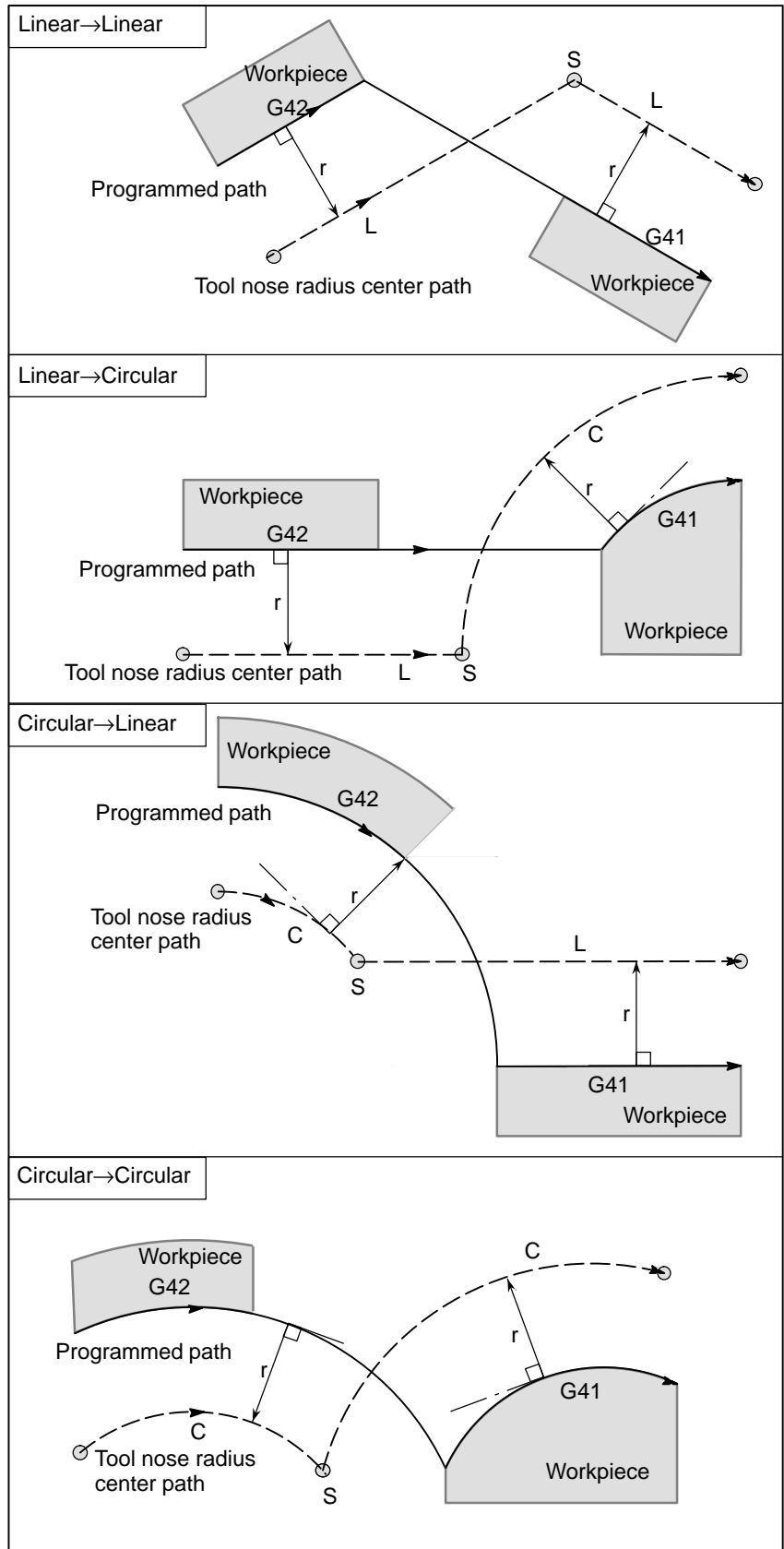

- Tool nose radius center path without an intersection

When changing the offset direction in block A to block B using G41 and G42, if intersection with the offset path is not required, the vector normal to block B is created at the start point of block B.

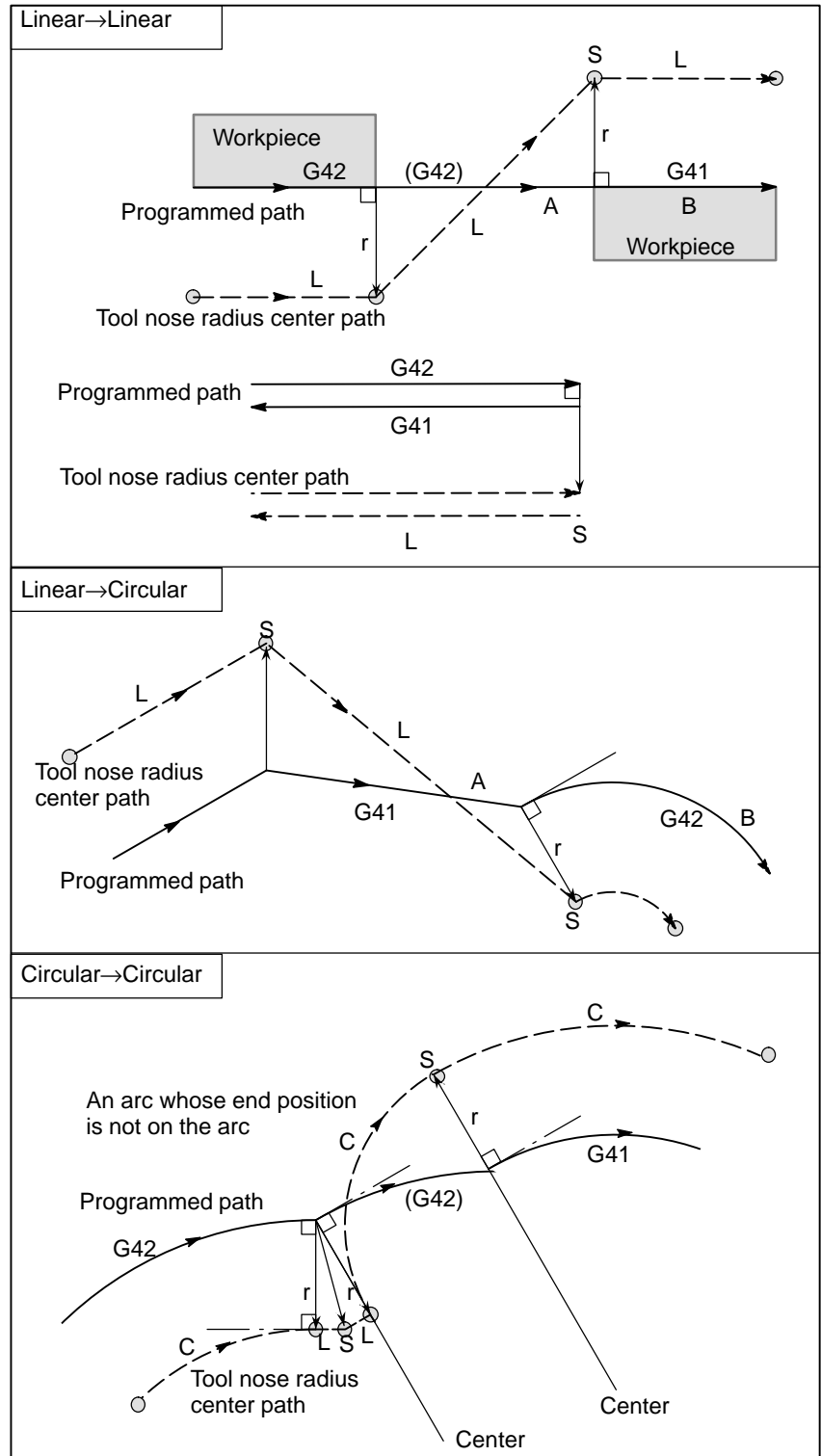

- **Temporary tool nose radius compensation cancel**

If the following command is specified in the offset mode, the offset mode is temporarily canceled then automatically restored. The offset mode can be canceled and started as described in Subsections II-14.3.2 and II-14.3.4.

- Specifying G28 (automatic return to the reference position) in the offset mode

If G28 is specified in the offset mode, the offset mode is canceled at an intermediate position. If the vector still remains after the tool is returned to the reference position, the components of the vector are reset to zero with respect to each axis along which reference position return has been made.

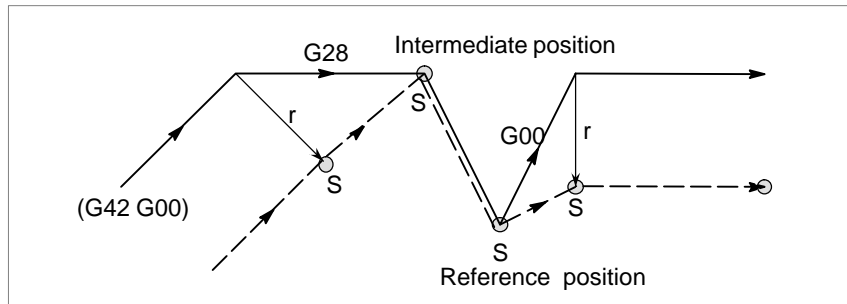

- Tool nose radius compensation G code in the offset mode

The offset vector can be set to form a right angle to the moving direction in the previous block, irrespective of machining inner or outer side, by commanding the tool nose radius compensation G code (G41, G42) in the offset mode, independently. If this code is specified in a circular command, correct circular motion will not be obtained.

When the direction of offset is expected to be changed by the command of tool nose radius compensation G code (G41, G42), refer to “Change in the offset direction in the offset mode” in Subsec.14.3.3.

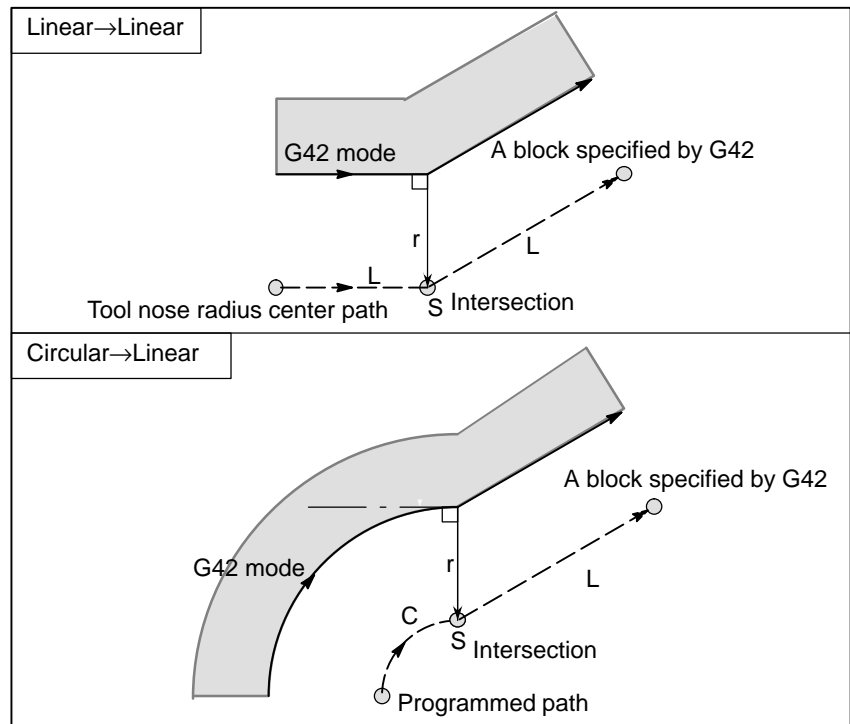

• **Command cancelling the offset vector temporality**

During offset mode, if G50 is commanded, the offset vector is temporarily cancelled and thereafter offset mode is automatically restored.

In this case, without movement of offset cancel, the tool moves directly from the intersecting point to the commanded point where offset vector is canceled. Also when restored to offset mode, the tool moves directly to the intersecting point.

• **Workpiece coordinate system setting (G50)**

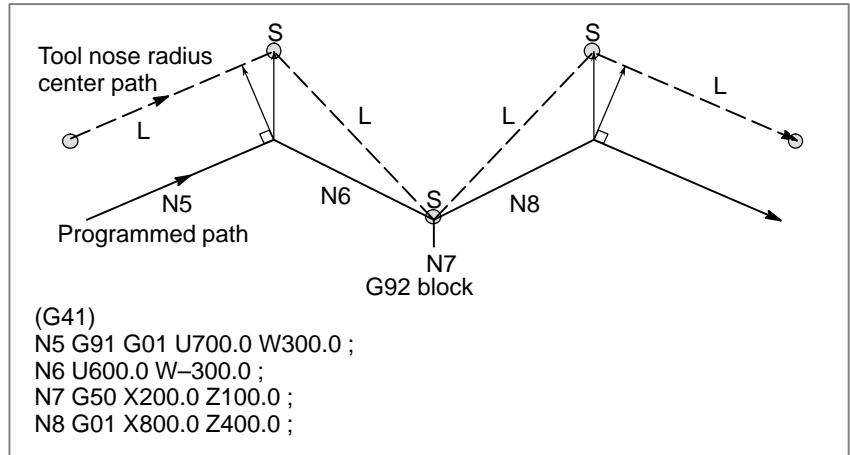

• **Canned cycles (G90, G92, G94) and Multiple repetitive cycles (G71 to G76)**

See Sections II-14.1 (G90, G92, G94) and II-14.2 (G70 to G76) for the tool nose radius compensation is related canned cycles.

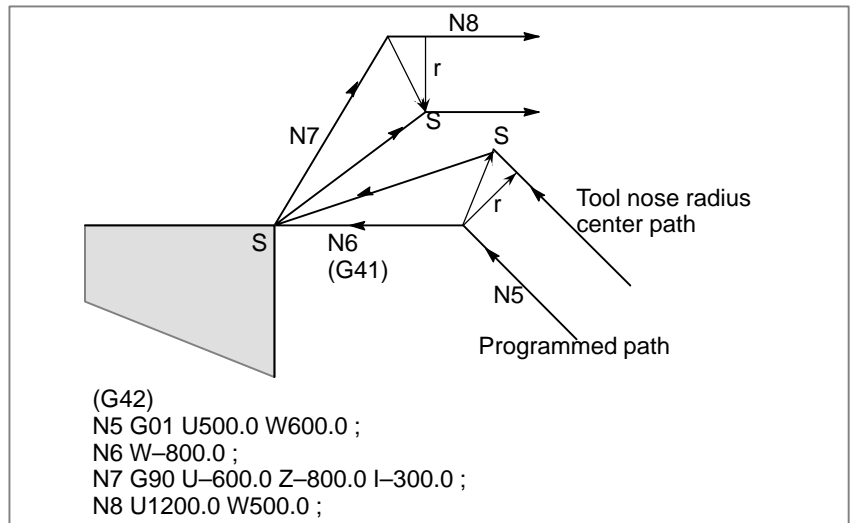

● **A block without tool movement**

The following blocks have no tool movement. In these blocks, the tool will not move even if tool nose radius compensation is effected.

1. M05 ; M code output
2. S21 ; S code output
3. G04 X10.0 ; Dwell
4. G10 P01 X10 Z20 R10.0 ; . tool nose radius compensation value setting
5. (G17) Z200.0 ; Move command not included in the offset plane.
6. G98 ; G code only
7. X0 ; Move distance is zero.

Commands 1 to 6 are of no movement.

● **A block without tool movement specified in offset mode**

When a single block without tool movement is commanded in the offset mode, the vector and Tool nose radius center path are the same as those when the block is not commanded. This block is executed at the single block stop point.

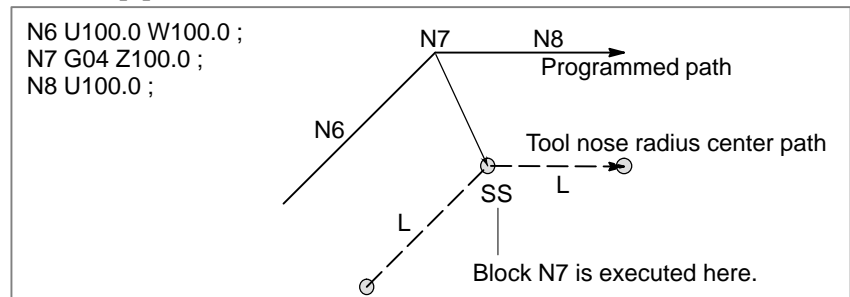

However, when the move distance is zero, even if the block is commanded singly, tool motion becomes the same as that when more than one block of without tool movement are commanded, which will be described subsequently.

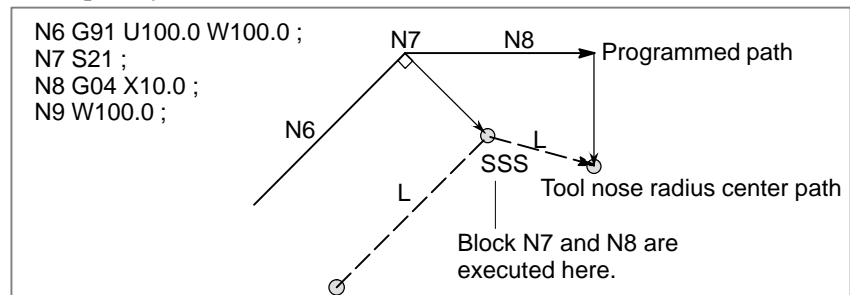

● **Corner movement**

When two or more vectors are produced at the end of a block, the tool moves linearly from one vector to another. This movement is called the corner movement.

If these vectors almost coincide with each other, the corner movement isn't performed and the latter vector is ignored.

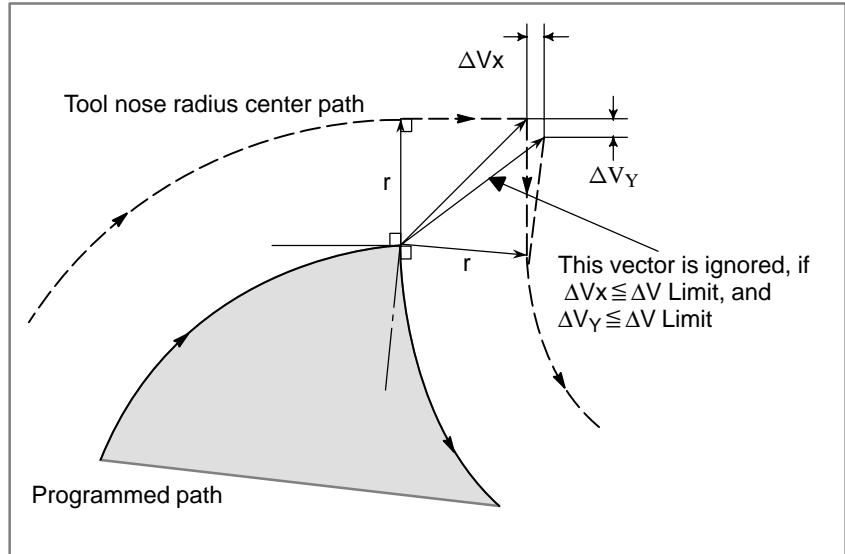

If $\Delta V_x \leq \Delta V_{limit}$ and $\Delta V_y \leq \Delta V_{limit}$, the latter vector is ignored. The ΔV_{limit} is set in advance by parameter (No. 5010).

If these vectors do not coincide, a move is generated to turn around the corner. This move belongs to the latter block.

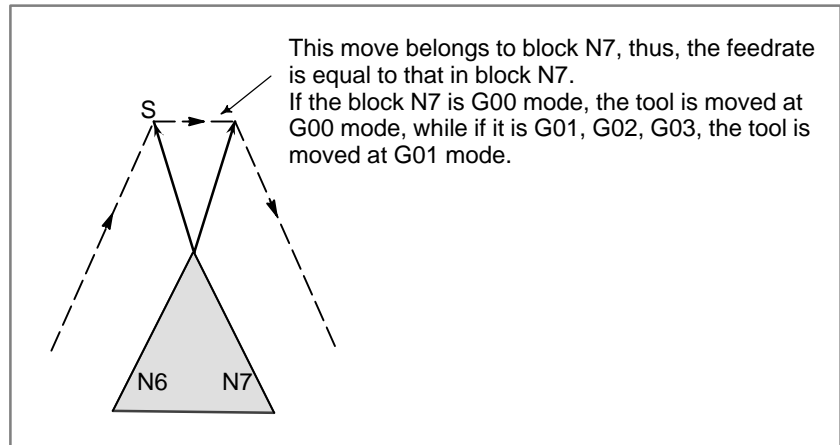

● **Interruption of manual operation**

For manual operation during the tool nose radius compensation, refer to Section III-3.5, "Manual Absolute ON and OFF."

14.3.4 Tool Movement in Offset Mode Cancel

Explanations

- Tool movement around an inside corner ($180^\circ \leq \alpha$)

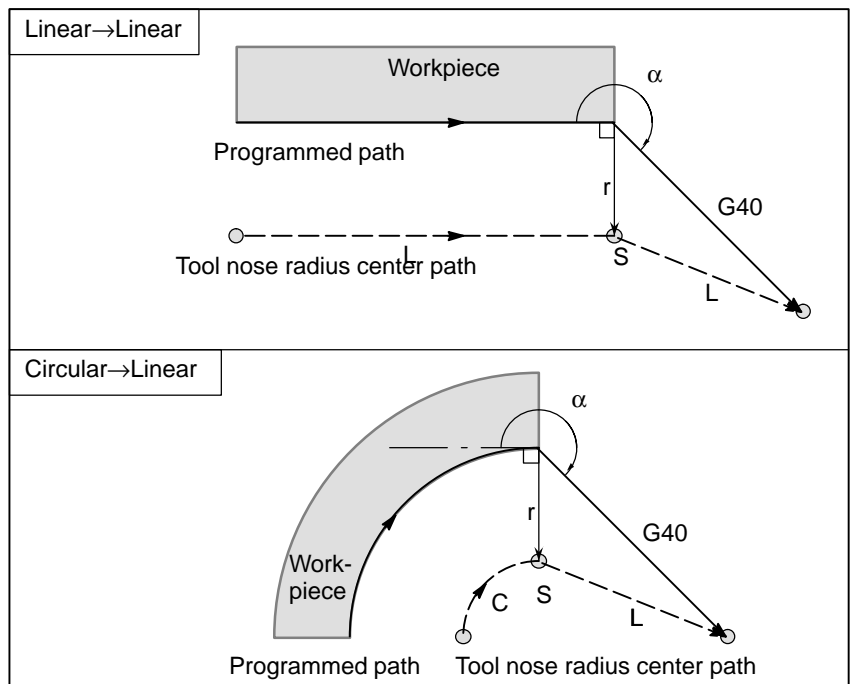

- Tool movement around an outside corner at an obtuse angle ($90^\circ \leq \alpha < 180^\circ$)

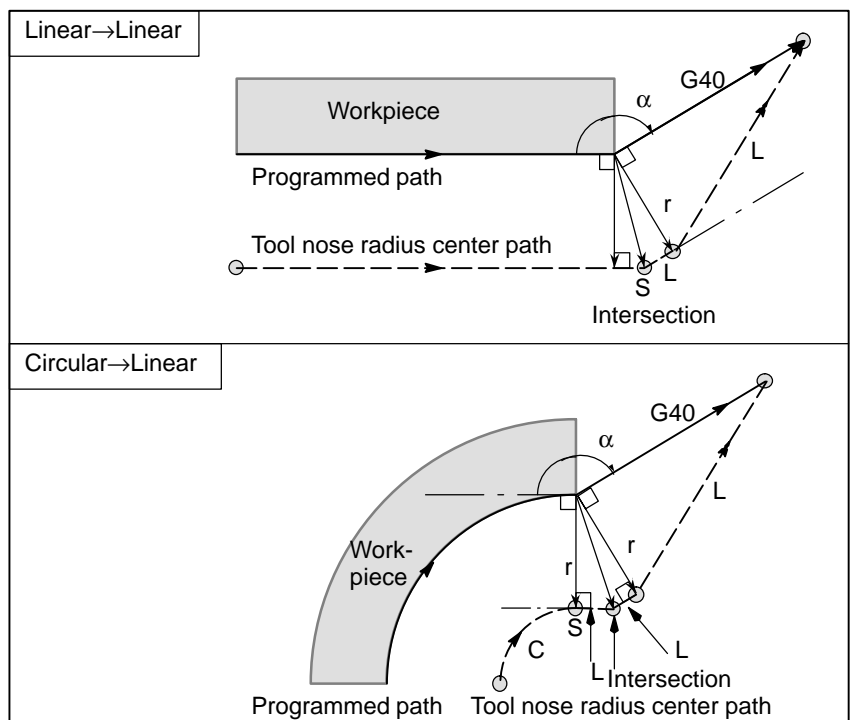

- Tool movement around an outside corner at an acute angle ($\alpha < 90^\circ$)

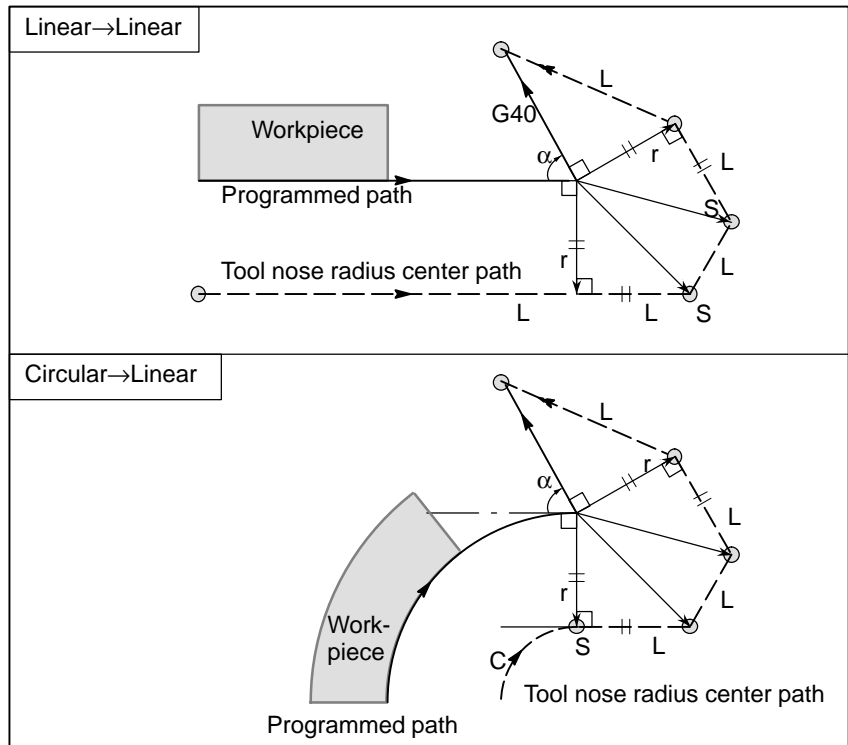

- Tool movement around the outside linear→linear at an acute angle less than 1 degree ($\alpha < 1^\circ$)

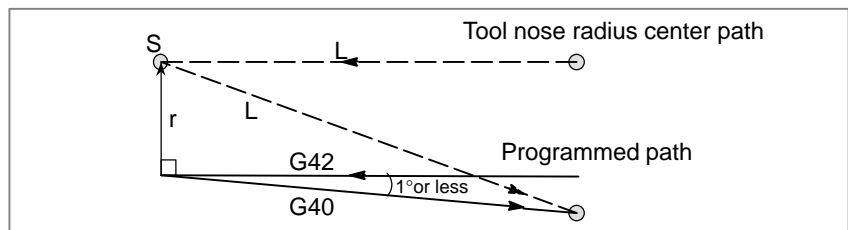

- A block without tool movement specified together with offset cancel

When a block without tool movement is commanded together with an offset cancel, a vector whose length is equal to the offset value is produced in a normal direction to tool motion in the earlier block, the vector is cancelled in the next move command.

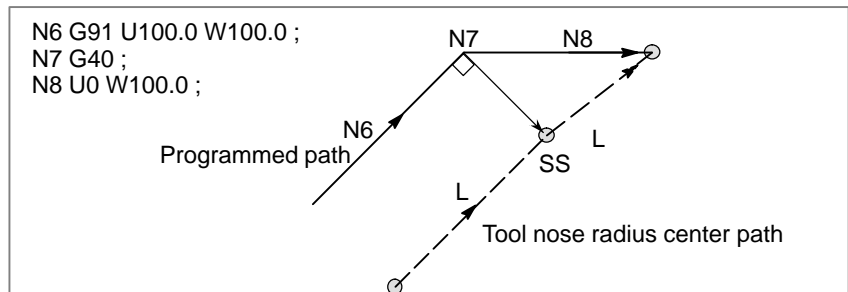

• **Block containing G40 and I_J_K_**

- The previous block contains G41 or G42

If a G41 or G42 block precedes a block in which G40 and I_, J_, K_ are specified, the system assumes that the path is programmed as a path from the end position determined by the former block to a vector determined by (I,J), (I,K), or (J,K). The direction of compensation in the former block is inherited.

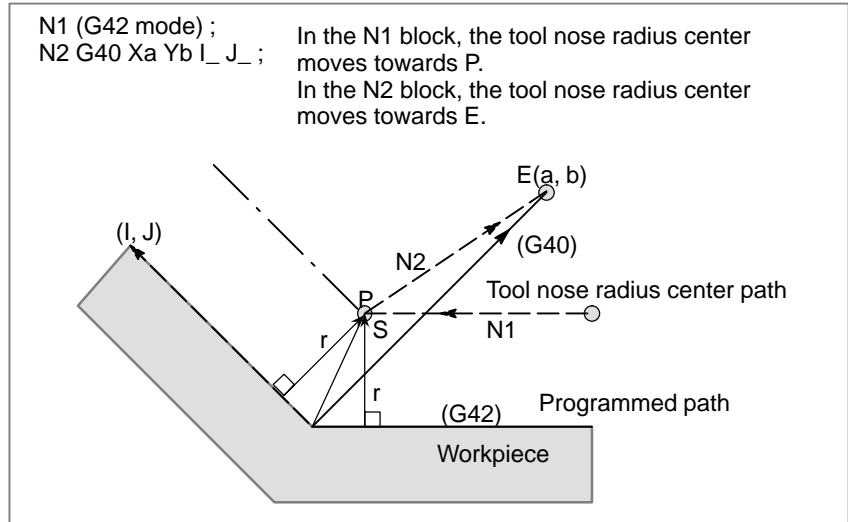

In this case, note that the CNC obtains an intersection of the tool path irrespective of whether inner or outer side machining is specified

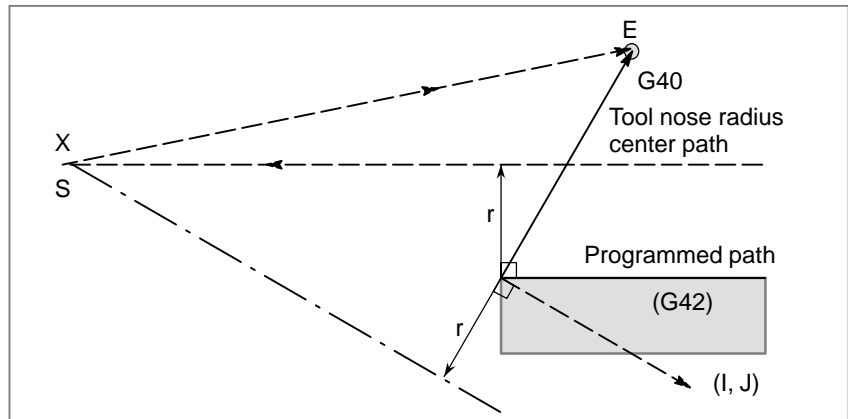

When an intersection is not obtainable, the tool comes to the normal position to the previous block at the end of the previous block.

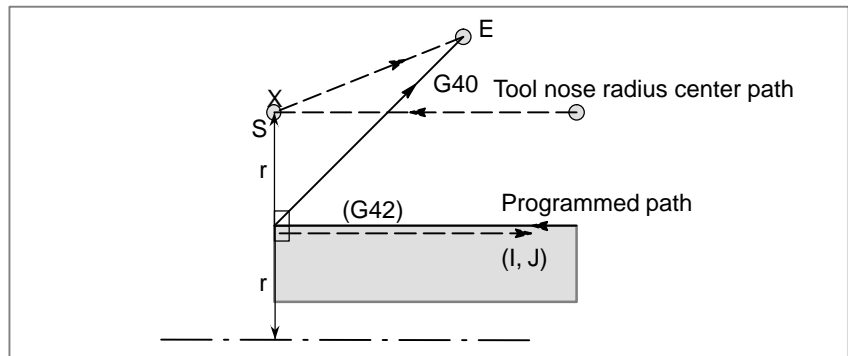

14.3.5 Interference Check

Tool overcutting is called interference. The interference check function checks for tool overcutting in advance. However, all interference cannot be checked by this function. The interference check is performed even if overcutting does not occur.

Explanations

- **Criteria for detecting interference**

- (1) The direction of the tool nose radius path is different from that of the programmed path (from 90 degrees to 270 degrees between these paths).

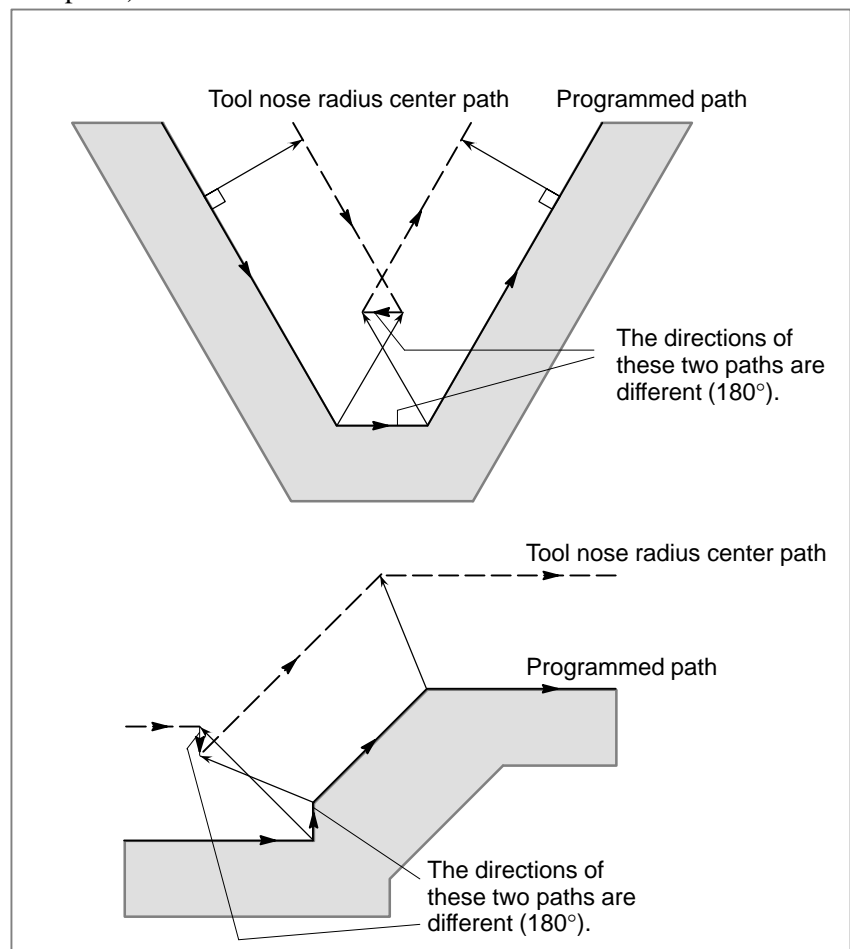

- (2) In addition to the condition (1), the angle between the start point and end point on the Tool nose radius center path is quite different from that between the start point and end point on the programmed path in circular machining (more than 180 degrees).

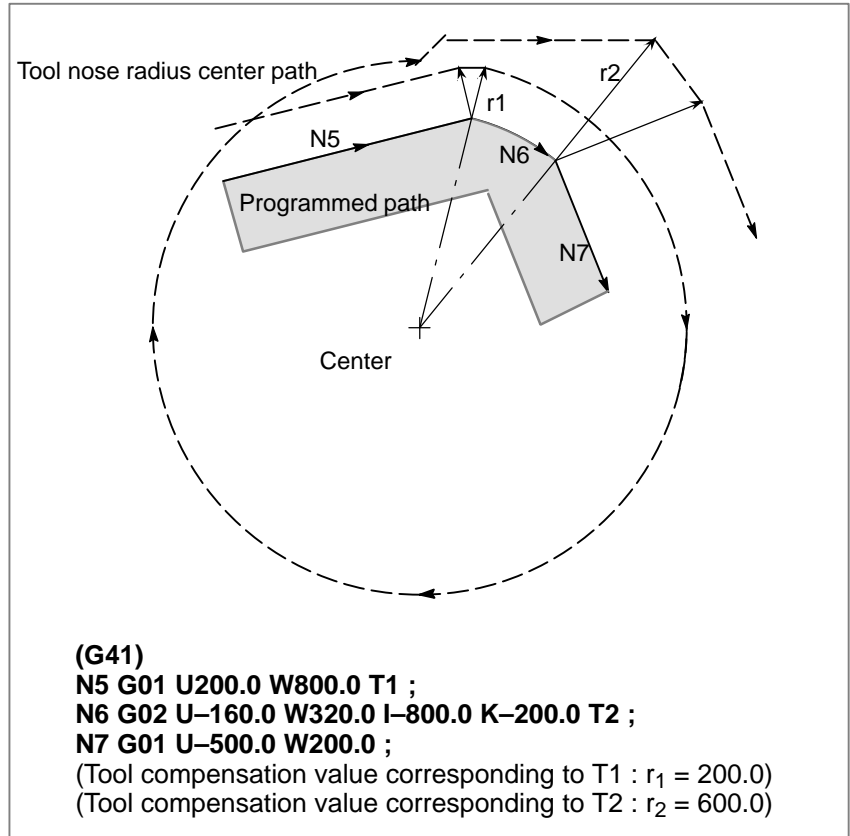

In the above example, the arc in block N6 is placed in the one quadrant. But after tool nose radius compensation, the arc is placed in the four quadrants.

● **Correction of interference in advance**

- (1) Removal of the vector causing the interference
 When tool nose radius compensation is performed for blocks A, B and C and vectors V_1, V_2, V_3 and V_4 between blocks A and B, and V_5, V_6, V_7 and V_8 between B and C are produced, the nearest vectors are checked first. If interference occurs, they are ignored. But if the vectors to be ignored due to interference are the last vectors at the corner, they cannot be ignored.

Check between vectors V_4 and V_5

Interference V_4 and V_5 are ignored.

Check between V_3 and V_6

Interference V_3 and V_6 are ignored

Check between V_2 and V_7

Interference V_2 and V_7 are Ignored

Check between V_1 and V_8

Interference V_1 and V_8 are cannot be ignored

If while checking, a vector without interference is detected, subsequent vectors are not checked. If block B is a circular movement, a linear movement is produced if the vectors are interfered.

(Example 1) The tool moves linearly from V_1 to V_8

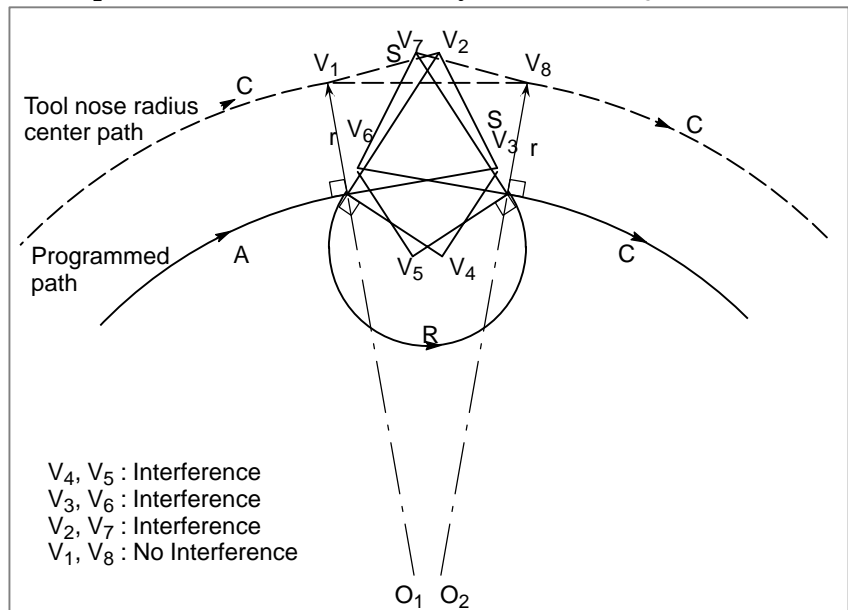

(Example 2) The tool moves linearly from V₁, V₂, V₇, to V₈

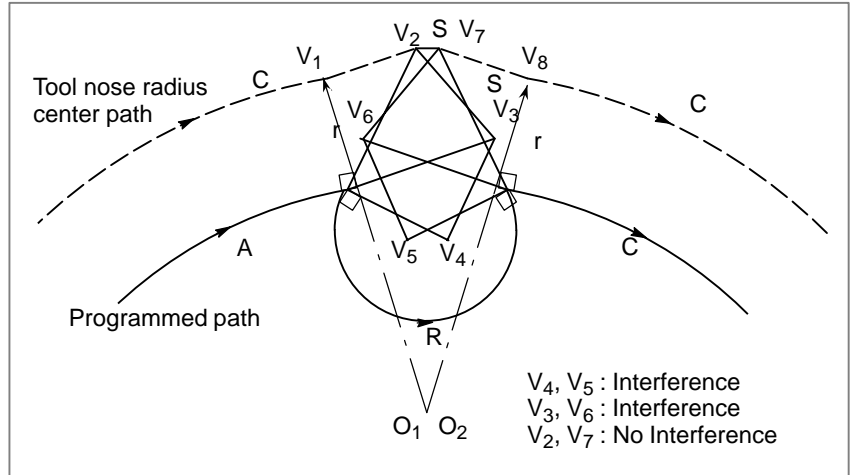

(2) If the interference occurs after correction (1), the tool is stopped with an alarm.

If the interference occurs after correction (1) or if there are only one pair of vectors from the beginning of checking and the vectors interfere, the P/S alarm (No. 41) is displayed and the tool is stopped immediately after execution of the preceding block. If the block is executed by the single block operation, the tool is stopped at the end of the block.

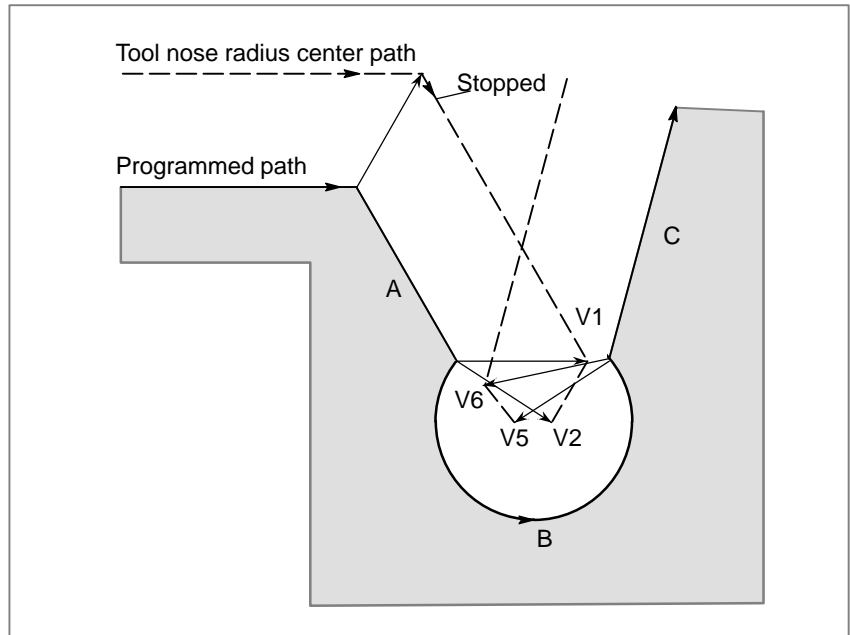

After ignoring vectors V_2 and V_5 because of interference, interference also occurs between vectors V_1 and V_6 . The alarm is displayed and the tool is stopped.

- When interference is assumed although actual interference does not occur

(1) Depression which is smaller than the tool nose radius compensation value

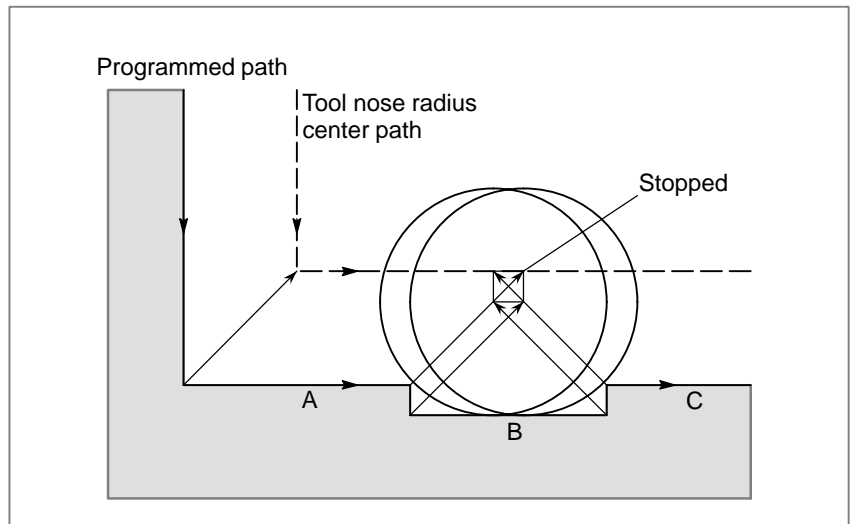

There is no actual interference, but since the direction programmed in block B is opposite to that of the path after tool nose radius compensation the tool stops and an P/S alarm (No. 041) is displayed.

(2) Groove which is smaller than the tool nose radius compensation value

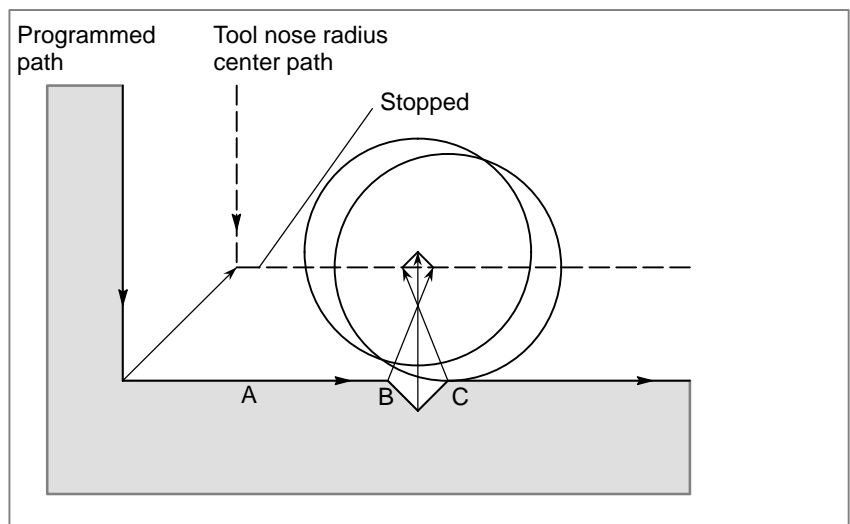

Like (1), the direction is reverse in block B.

14.3.6 Overcutting by Tool Nose Radius Compensation

Explanations

- **Machining an inside corner at a radius smaller than the tool nose radius**

When the radius of a corner is smaller than the cutter radius, because the inner offsetting of the cutter will result in overcuttings, an alarm is displayed and the CNC stops at the start of the block. In single block operation, the overcutting is generated because the tool is stopped after the block execution.

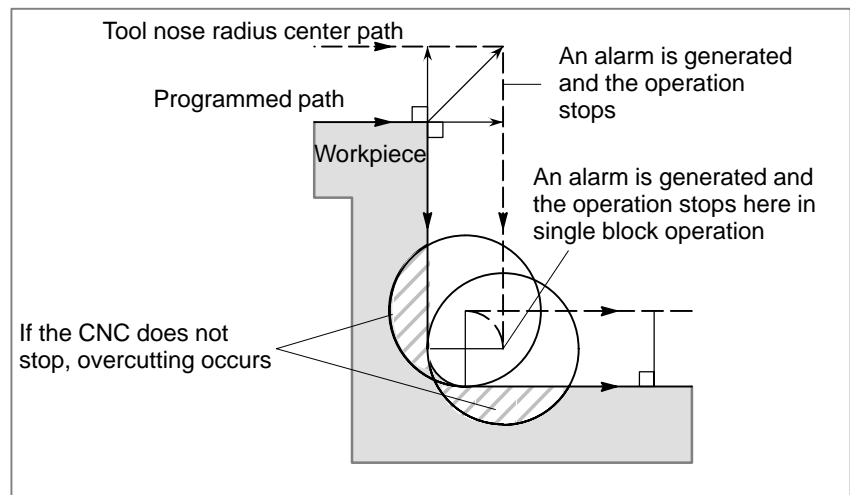

- **Machining a groove smaller than the tool nose radius**

Since the tool nose radius compensation forces the path of the center of the tool to move in the reverse of the programmed direction, overcutting will result. In this case an alarm is displayed and the CNC stops at the start of the block.

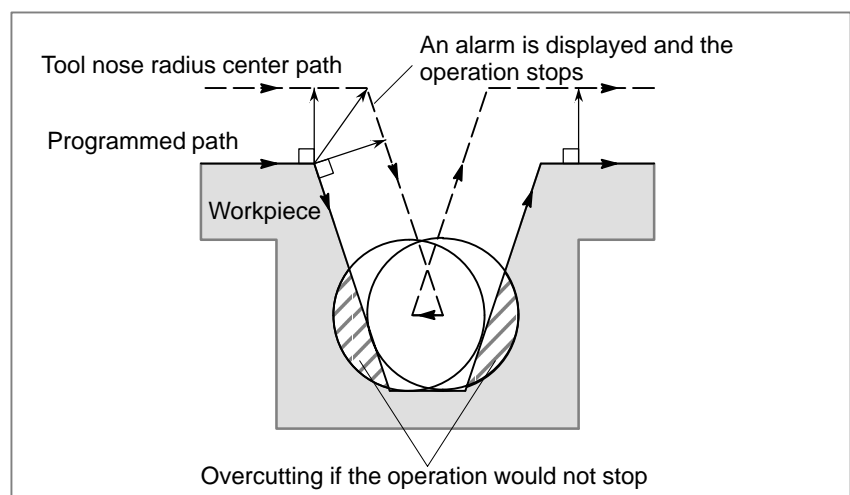

● **Machining a step smaller than the tool nose radius**

When machining of the step is commanded by circular machining in the case of a program containing a step smaller than the tool nose radius, the path of the center of tool with the ordinary offset becomes reverse to the programmed direction. In this case, the first vector is ignored, and the tool moves linearly to the second vector position. The single block operation is stopped at this point. If the machining is not in the single block mode, the cycle operation is continued. If the step is of linear, no alarm will be generated and cut correctly. However uncut part will remain.

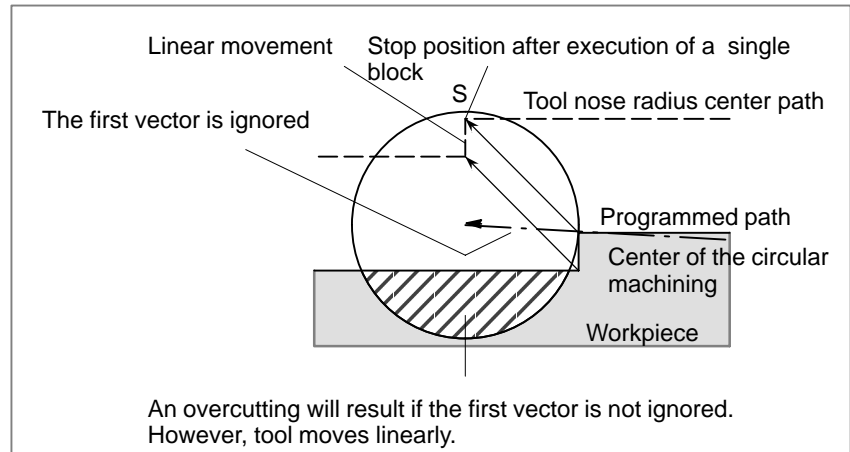

14.3.7 Correction in Chamfering and Corner Arcs

In chamfering or corner arcs, tool nose radius compensation only be performed when an ordinary intersection exists at the corner.

In offset cancel mode, a start-up block or when exchanging the offset direction, compensation cannot be performed, an P/S alarm (No. 39) is displayed and the tool is stopped.

In inner chamfering or inner corner arcs, if the chamfering value or corner arc value is smaller than the tool nose radius value, the tool is stopped with an P/S alarm (No. 39) since overcutting will occur.

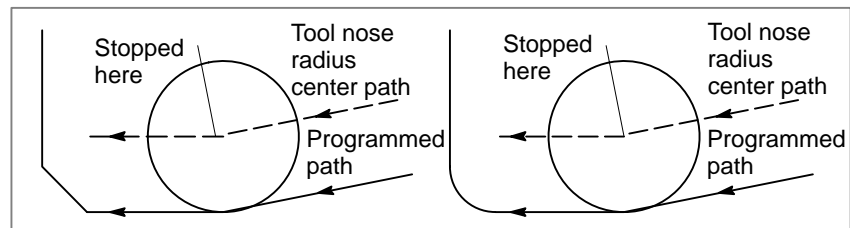

The valid inclination angle of the programmed path in the blocks before and after the corner is 1 degree or less so that the P/S alarm (No. 52, 54) generated by the calculating error of tool nose radius compensation does not occur.

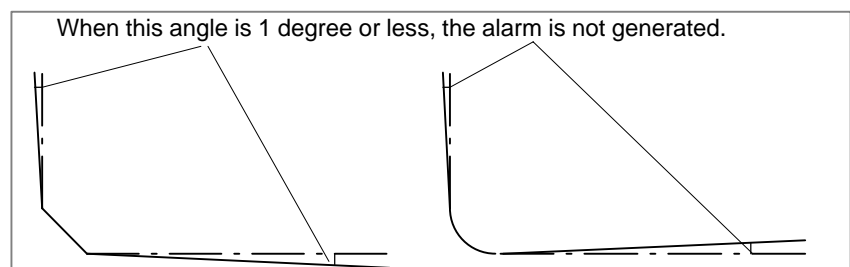

- **When machining area remains or an alarm is generated**

The following example shows a machining area which cannot be cut sufficiently.

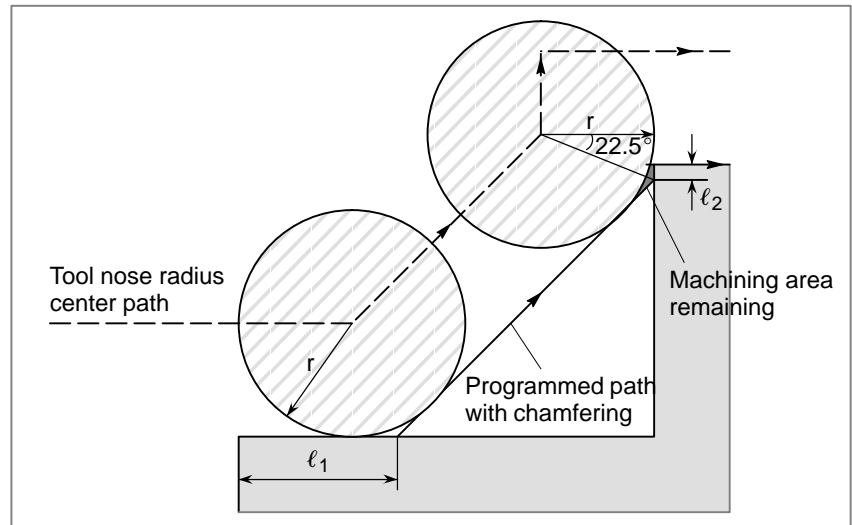

In inner chamfering, if the portion of the programmed path that is not a part of the chamfering (in the above figure ℓ_1 or ℓ_2) is in following range, insufficiently cut are will exist.

$$0 \leq \ell_1 \text{ or } \ell_2 < r \cdot \tan 22.5^\circ \text{ (r: too nose radius)}$$

Enlarged view on the remaining machining area

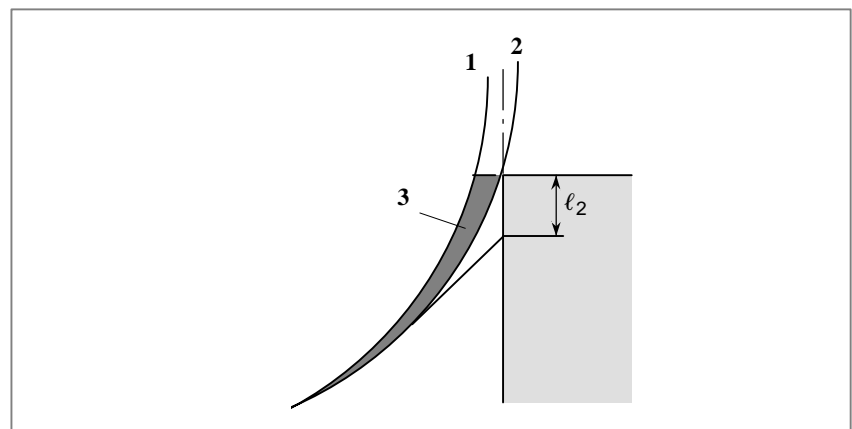

Although the tool should be positioned at 2 in the above figure, the tool is positioned at 1 (the tool nose is tangent to line L).

Thus, area 3 is not machined.

P/S alarm No. 52 or 55 is displayed in the following cases :

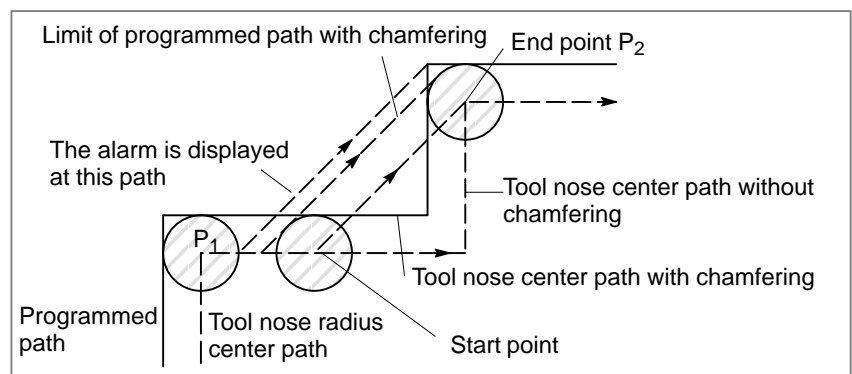

In outer chamfering with an offset, a limit is imposed on the programmed path. The path during chamfering coincides with the intersection points P_1 or P_2 without chamfering, therefore, outer chamfering is limited. In the figure above, the end point of the tool center path with chamfering coincides with the intersection point (P_2) of the next block without chamfering. If the chamfering value is more than the limit value specified, P/S alarm No. 52 or 55 will be displayed.

14.3.8 Input Command from MDI

Tool nose radius compensation is not performed for commands input from the MDI.

However, when automatic operation using absolute commands is temporarily stopped by the single block function, MDI operation is performed, then automatic operation starts again, the tool path is as follows :

In this case, the vectors at the start position of the next block are translated and the other vectors are produced by the next two blocks. Therefore, from next block but one, tool nose radius compensation is accurately performed.

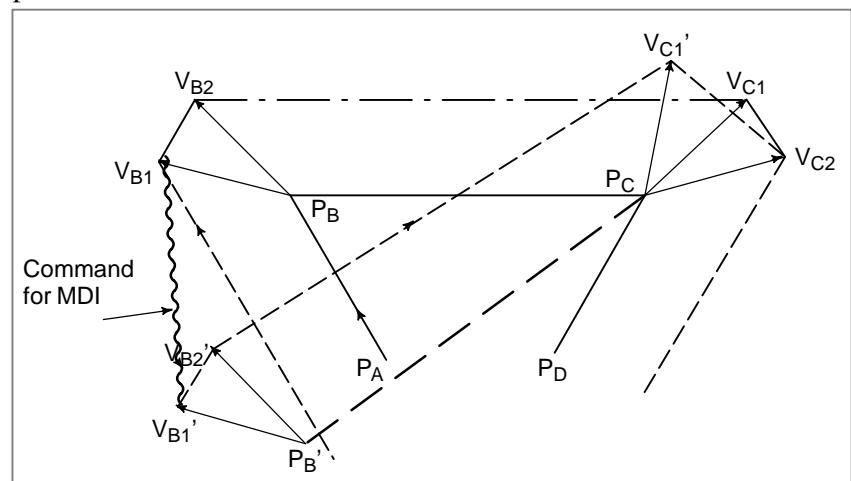

When position P_A , P_B , and P_C are programmed in an absolute command, tool is stopped by the single block function after executing the block from P_A to P_B and the tool is moved by MDI operation. Vectors V_{B1} and V_{B2} are translated to V_{B1}' and V_{B2}' and offset vectors are recalculated for the vectors V_{C1} and V_{C2} between block P_B - P_C and P_C - P_D .

However, since vector V_{B2} is not calculated again, compensation is accurately performed from position P_C .

14.3.9 General Precautions for Offset Operations

- **Changing the offset value**

In general, the offset value is changed in cancel mode, or when changing tools. If the offset value is changed in offset mode, the vector at the end point of the block is calculated for the new offset value.

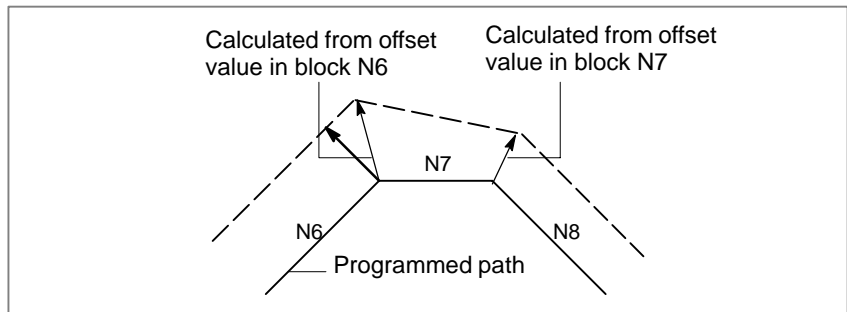

When some vectors are produced between blocks N6 and N7, the vector at the end point of the present blocks is calculated using the offset value of the block N6.

- **The polarity of the offset amount and the tool nose center path**

When a negative offset value is specified, the program is executed for the figure which is created by exchanging G41 for G42 or G42 for G41 in the process sheet.

A tool machining an inner profile will machine the occur profile, and tool machining the outer profile will machine the inner profile.

An example is shown below. In general, CNC machining is programmed assuming a positive offset value. When a program specifies a tool path as shown in **1**, the tool will move as shown in **2** if a negative offset is specified. The tool in **2** will move as shown in **1** when the sign of the offset value is reversed.

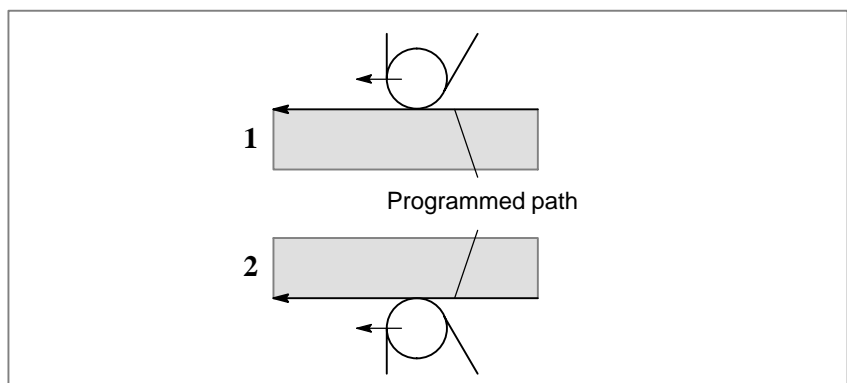

WARNING

When the sign of the offset value is reversed, the offset vector of the tool nose is reversed but the imaginary tool nose direction does not change.

Therefore, do not reverse the sign of the offset value when starting the machining meeting the imaginary tool nose to the start point.

14.3.10 G53, G28, G30, and G30.1 Commands in Tool-tip Radius Compensation Mode

- When a G53 command is executed in tool-tip radius compensation mode, the tool-tip radius compensation vector is automatically canceled before positioning, that vector being automatically restored by a subsequent move command. The format for restoring the tool-tip radius compensation vector is the FS16 type when bit 2 (CCN) of parameter No. 5003 is set to 0, or the FS15 type when the bit is set to 1.
- When a G28, G30, or G30.1 command is executed in tool-tip radius compensation mode, the tool-tip radius compensation vector is automatically canceled before automatic reference position return, that vector being automatically restored by a subsequent move command. The timing and format for canceling and restoring the tool-tip radius compensation vector are the FS15 type when bit 2 (CCN) of parameter No. 5003 is set to 1, or the FS16 type when the bit is set to 0.

Explanations

- **G53 command in tool-tip radius compensation mode**

When a G53 command is executed in tool-tip radius compensation mode, a vector having a length equal to the offset is created, at the end of the preceding block, perpendicular to the direction in which the tool moves. When the tool moves to a specified position according to the G53 command, the offset vector is canceled. When the tool moves according to the next command, the offset vector is automatically restored.

The format for restoring the tool-tip radius compensation vector is the start-up type when bit 2 (CCN) of parameter No. 5003 is set to 0, or the intersection vector type (FS15 type) when the bit is set to 1.

- G53 command in offset mode

When bit 2 (CCN) of parameter No. 5003 is set to 0

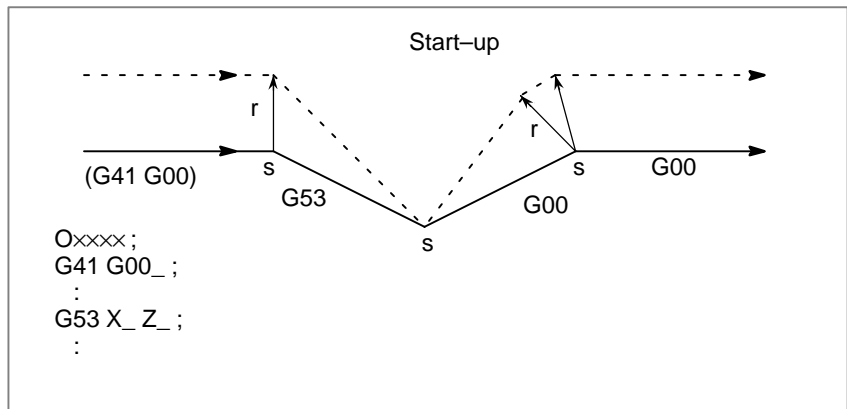

When bit 2 (CCN) of parameter No. 5003 is set to 1

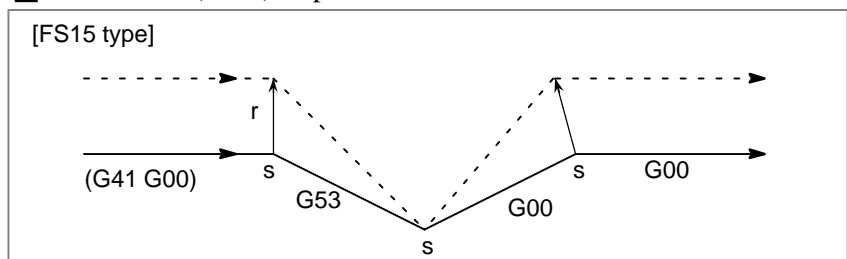

- Incremental G53 command in offset mode

When bit 2 (CCN) of parameter No. 5003 is set to 0

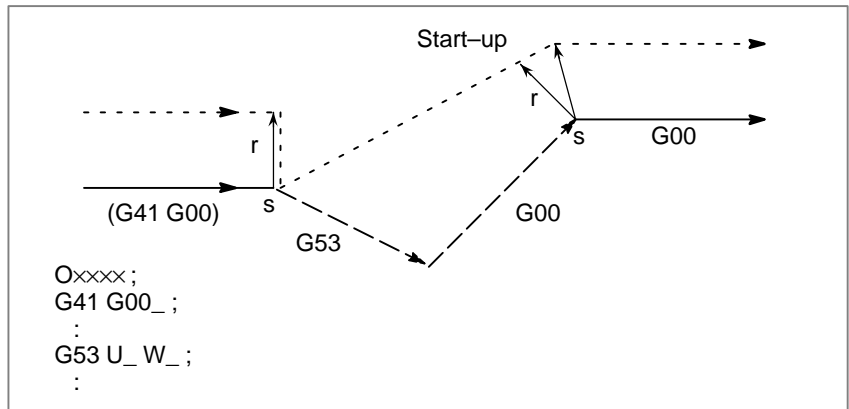

When bit 2 (CCN) of parameter No. 5003 is set to 1

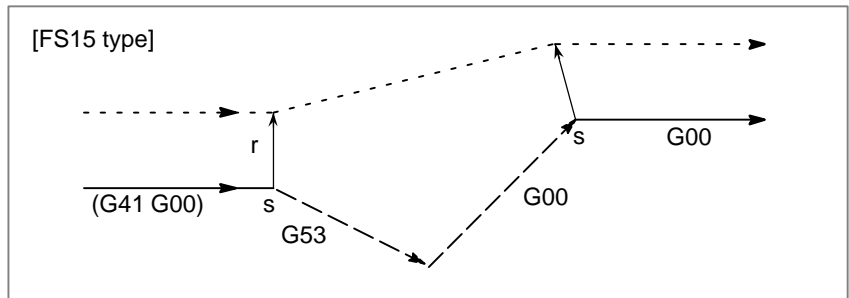

- G53 command specifying no movement in offset mode

When bit 2 (CCN) of parameter No. 5003 is set to 0

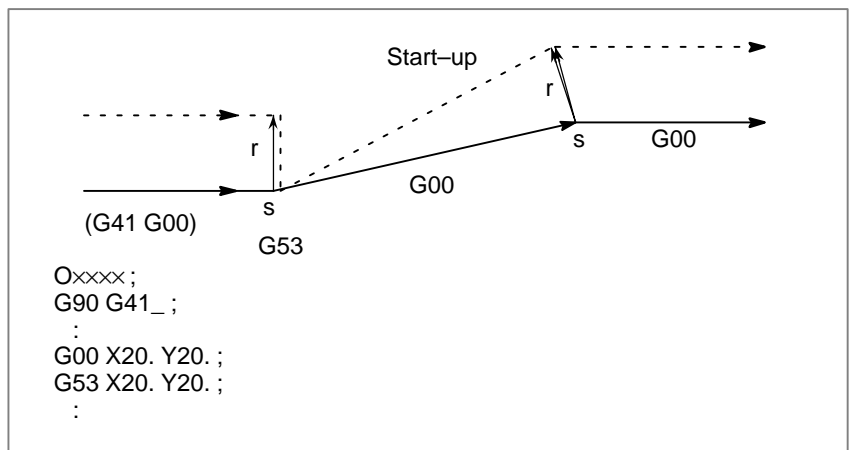

When bit 2 (CCN) of parameter No. 5003 is set to 1

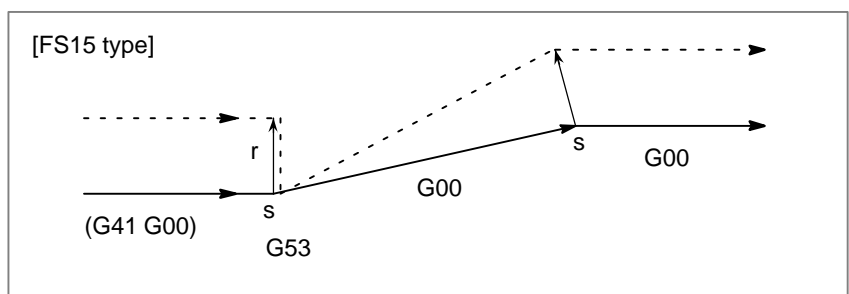

WARNING

1 When a G53 command is executed in tool-tip radius compensation mode when all-axis machine lock is applied, positioning is not performed for those axes to which machine lock is applied and the offset vector is not canceled. When bit 2 (CCN) of parameter No. 5003 is set to 0 or each-axis machine lock is applied, the offset vector is canceled.

Example 1)

When bit 2 (CCN) of parameter No. 5003 is set to 0 and all-axis machine lock is applied

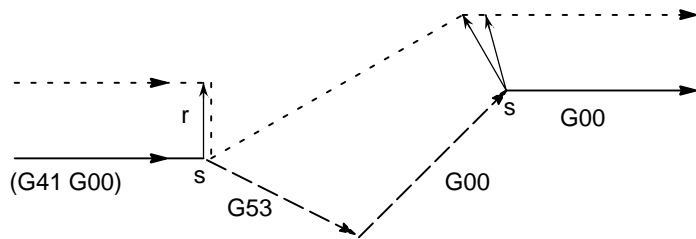

Example 2)

When bit 2 (CCN) of parameter No. 5003 is set to 1 and all-axis machine lock is applied

[FS15 type]

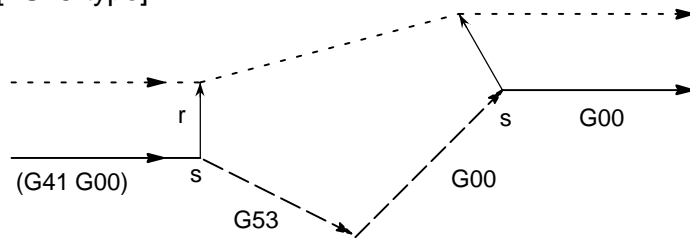

Example 3)

When bit 2 (CCN) of parameter No. 5003 is set to 1 and each-axis machine lock is applied

[FS15 type]

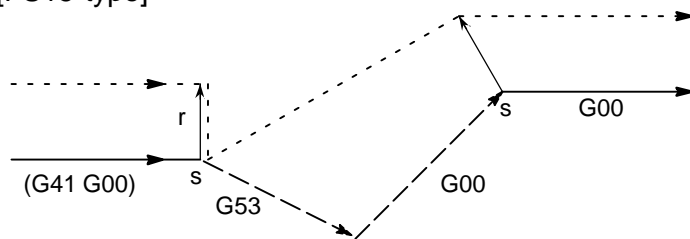

WARNING

2 When a compensation axis is specified in a G53 command in tool-tip radius compensation mode, the vectors for other compensation axes are also canceled. This also applies when bit 2 (CCN) of parameter No. 5003 is set to 1. (The FS15 cancels only the vector for the specified axis. Note that the FS15 type cancellation differs from the actual FS15 specification in this point.)

Example)

When bit 2 (CCN) of parameter No. 5003 is set to 0

[FS15 type]

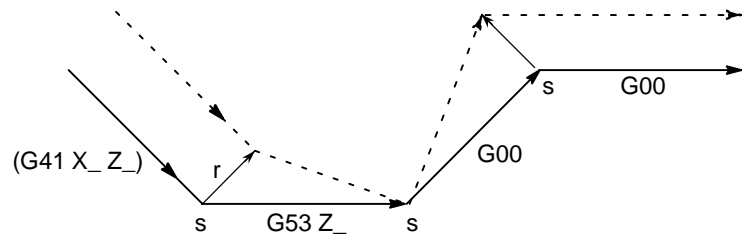

NOTE

1 When an axis not included in the tool-tip radius compensation plane is specified in a G53 command, a vector perpendicular to the direction in which the tool moves is created at the end of the preceding block and the tool does not move. Offset mode is automatically resumed from the next block (in the same way as when two or more blocks specifying no movement are consecutively executed).

Example)

When bit 2 (CCN) of parameter No. 5003 is set to 0

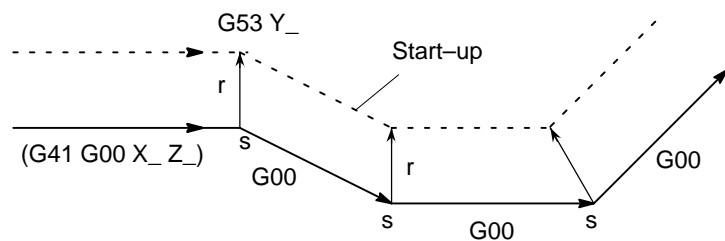

2 When a G53 command is specified as a start-up block, the next block actually becomes the start-up block. When bit 2 (CCN) of parameter No. 5003 is set to 1, however, the next block creates an intersection vector.

Example)

When bit 2 (CCN) of parameter No. 5003 is set to 0

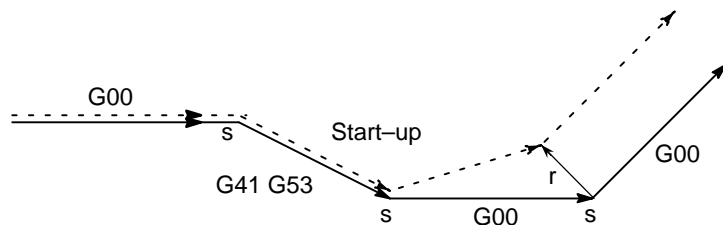

- **G28, G30, G30.1 command in tool-tip radius compensation mode**

When a G28, G30, or G30.1 command is executed in tool-tip radius compensation mode, the operation specified in the command is performed according to the FS15 format if bit 2 (CCN) of parameter No. 5003 is set to 1. An intersection vector is created at the end of the preceding block and a perpendicular vector is created at the intermediate position. The offset vector is canceled when the tool moves from the intermediate position to the reference position. The offset vector is restored as an intersection vector by the next block.

- G28, G30, or G30.1 command in offset mode (with movement to both an intermediate position and reference position performed)

When bit 2 (CCN) of parameter No. 5003 is set to 0

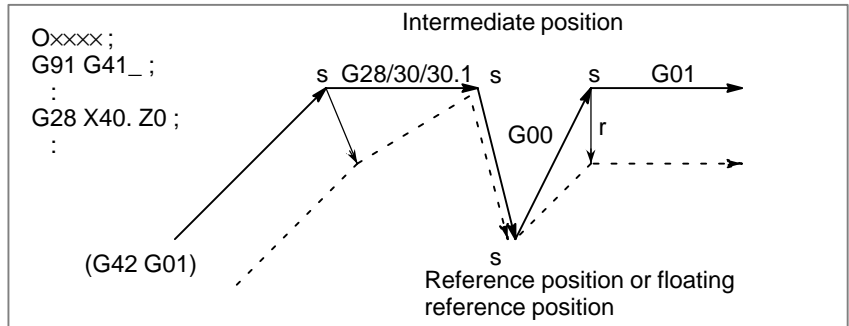

When bit 2 (CCN) of parameter No. 5003 is set to 1

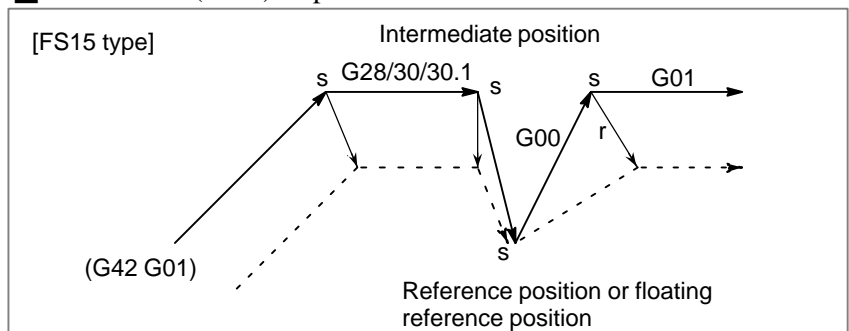

- G28, G30, or G30.1 command in offset mode (with movement to an intermediate position not performed)

When bit 2 (CCN) of parameter No. 5003 is set to 0

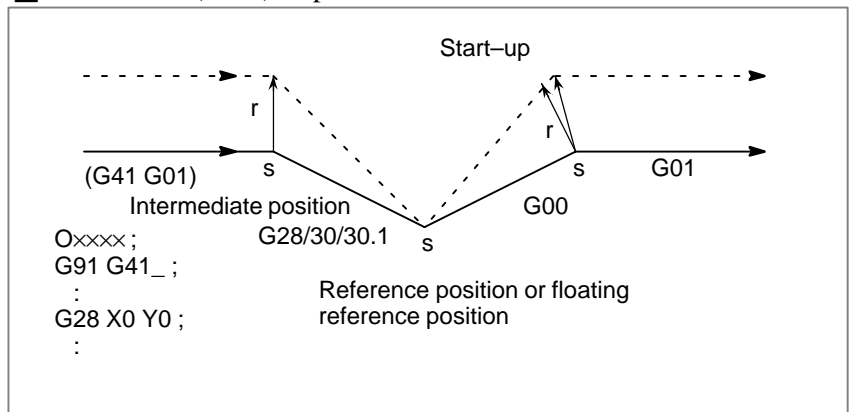

When bit 2 (CCN) of parameter No. 5003 is set to 1

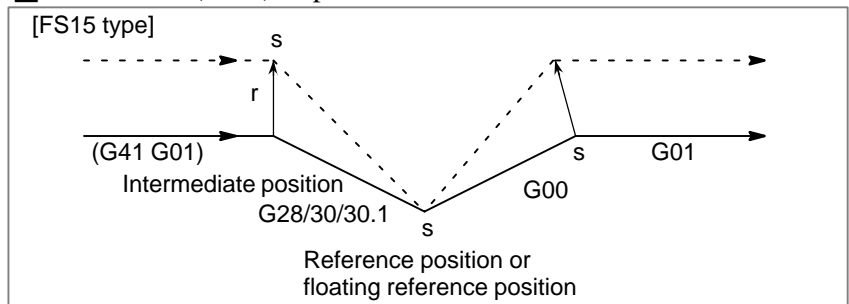

- G28, G30, or G30.1 command in offset mode (with movement to a reference position not performed)

When bit 2 (CCN) of parameter No. 5003 is set to 0

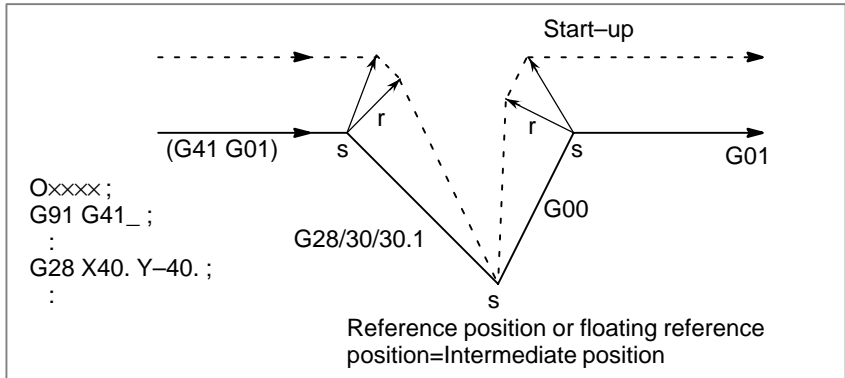

When bit 2 (CCN) of parameter No. 5003 is set to 1

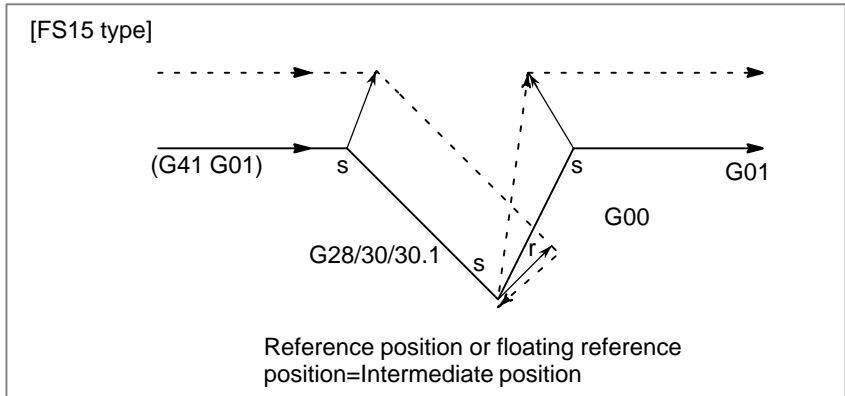

- G28, G30, or G30.1 command in offset mode (with no movement)

When bit 2 (CCN) of parameter No. 5003 is set to 0

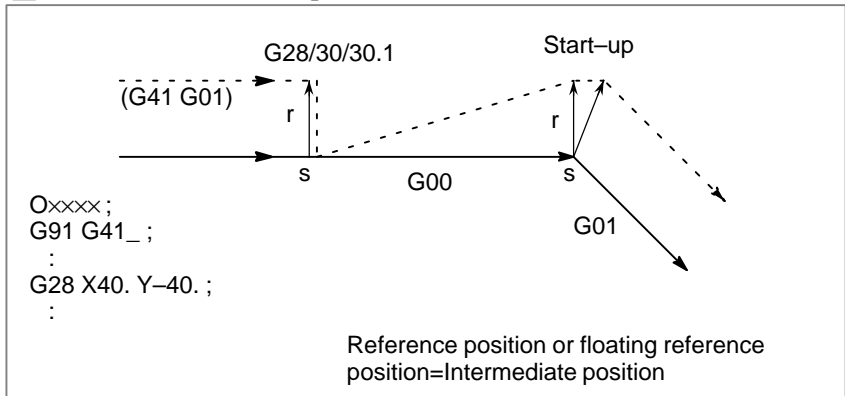

When bit 2 (CCN) of parameter No. 5003 is set to 1

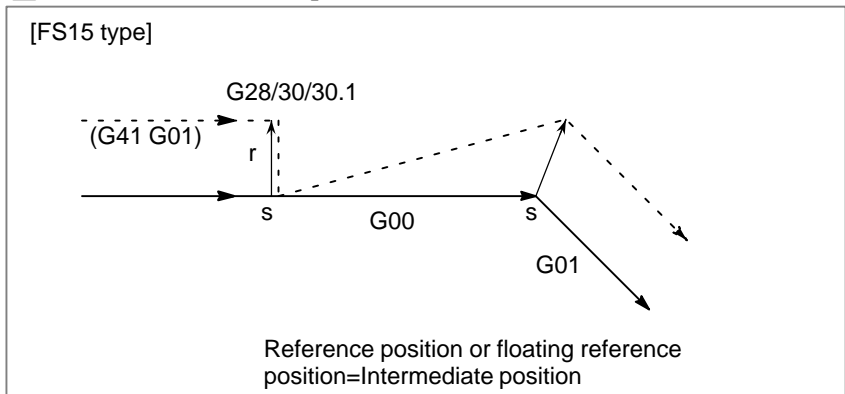

WARNING

1 When a G28, G30, or G30.1 command is executed when all-axis machine lock is applied, a vector perpendicular to the direction in which the tool moves is created at the intermediate position. In this case, the tool does not move to the reference position and the offset vector is not canceled. When bit 2 (CCN) of parameter No. 5003 is set to 0 or each-axis machine lock is applied, the offset vector is canceled.

Example 1)

When bit 2 (CCN) of parameter No. 5003 is set to 1.

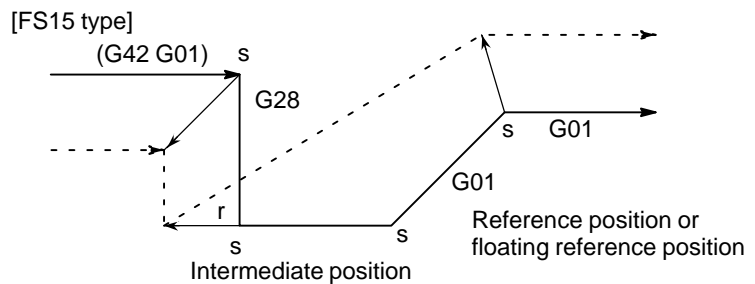

Example 2)

When bit 2 (CCN) of parameter No. 5003 is set to 0 and all-axis machine lock is applied

[FS15 type]

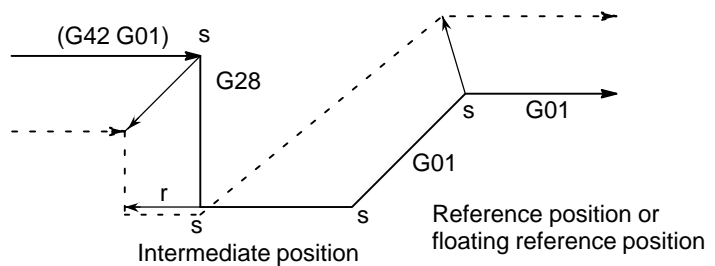

2 When a compensation axis is specified in a G28, G30, or G30.1 command in tool-tip radius compensation mode, the vectors for other compensation axes are also canceled. This also applies when bit 2 (CCN) of parameter No. 5003 is set to 1. (The FS15 cancels only the vector for the specified axis. Note that the FS15 type cancellation differs from the actual FS15 specification in this point.)

[FS15 type]

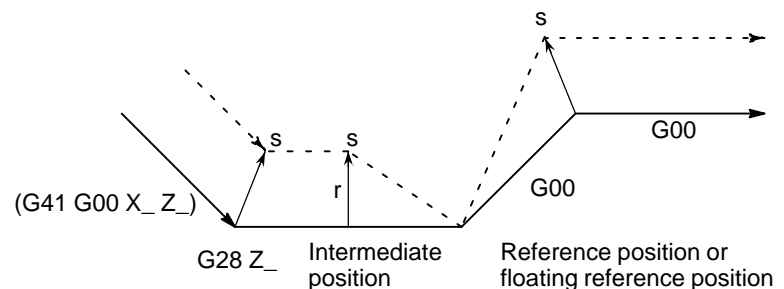

NOTE

1 When an axis not included in the tool-tip radius compensation plane is specified in a G28, G30, or G30.1 command, a vector perpendicular to the direction in which the tool moves is created at the end of the preceding block and the tool does not move. Offset mode is automatically resumed from the next block (in the same way as when two or more blocks specifying no movement are consecutively executed).

Example)

When bit 2 (CCN) of parameter No. 5003 is set to 1.

[FS15 type]

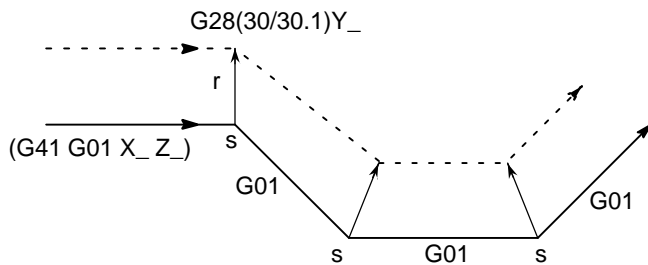

2 When a G28, G30, or G30.1 command is specified as a start-up block, a vector perpendicular to the direction in which the tool moves is created at the intermediate position. The vector is then canceled at the reference position. The next block creates an intersection vector.

Example 1)

When bit 2 (CCN) of parameter No. 5003 is set to 1.

[FS15 type]

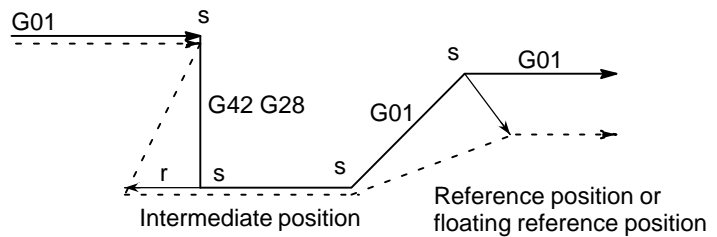

14.4 CORNER CIRCULAR INTERPOLATION FUNCTION (G39)

During radius compensation for the tool tip, corner circular-interpolation, with the specified compensation value used as the radius, can be performed by specifying G39 in offset mode.

Format

In offset mode, specify

G39;

or

G39 $\left\{ \begin{array}{l} \underline{I} \ \underline{J} \\ \underline{I} \ \underline{K} \\ \underline{J} \ \underline{K} \end{array} \right\};$

Explanations

- **Corner circular-interpolation**

Corner circular-interpolation, with the specified compensation value used as a radius, can be performed by specifying the operation as shown above. Whether the tool moves clockwise or counterclockwise depends on whether the last-specified direction code is G41 or G42. G39 is a single-shot G code.

- **G39 without I, J, and K**

Specifying G39; creates a corner arc for which the end vector is perpendicular to the start point of the next block.

- **G39 with I, J, and K**

Specifying G39 I_J_K_; creates a corner arc for which the end vector is perpendicular to the vector specified with I, J, and K.

Limitations

- **Move command**

A move operation cannot be specified in a block in which G39 is specified.

- **Non-move command**

Two or more contiguous blocks with no move operations can not be specified immediately after a block in which G39, without I, J, and K, is specified. (If a move command is specified in a block with a move distance of 0, it is assumed to be two or more contiguous blocks with no more operations.) If those blocks are specified, the offset vector momentarily disappears and the system automatically returns to offset mode.

Examples

• **G39 without I, J, and K**

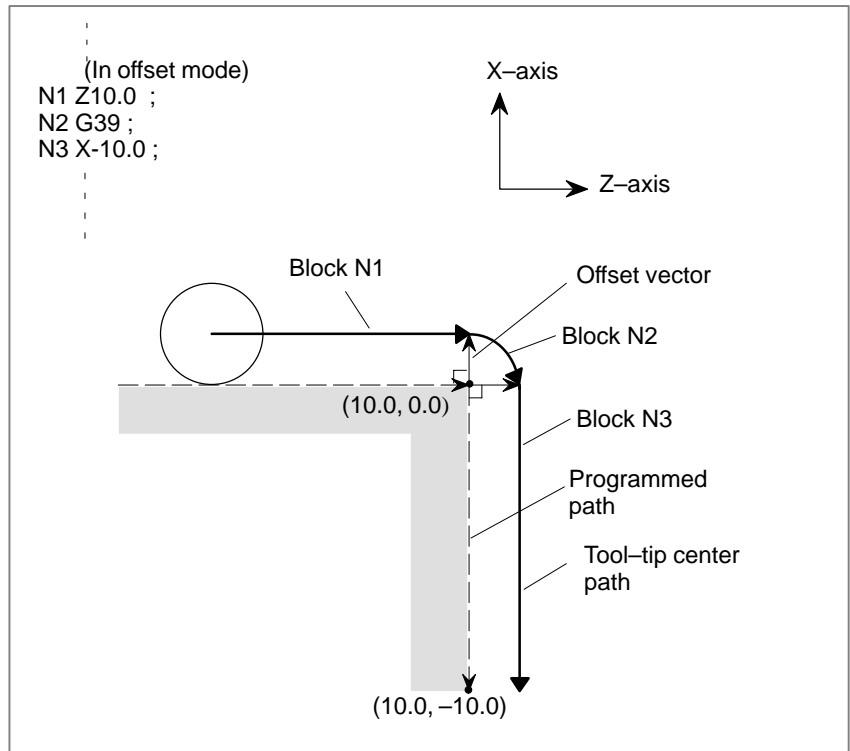

• **G39 with I, J, and K**

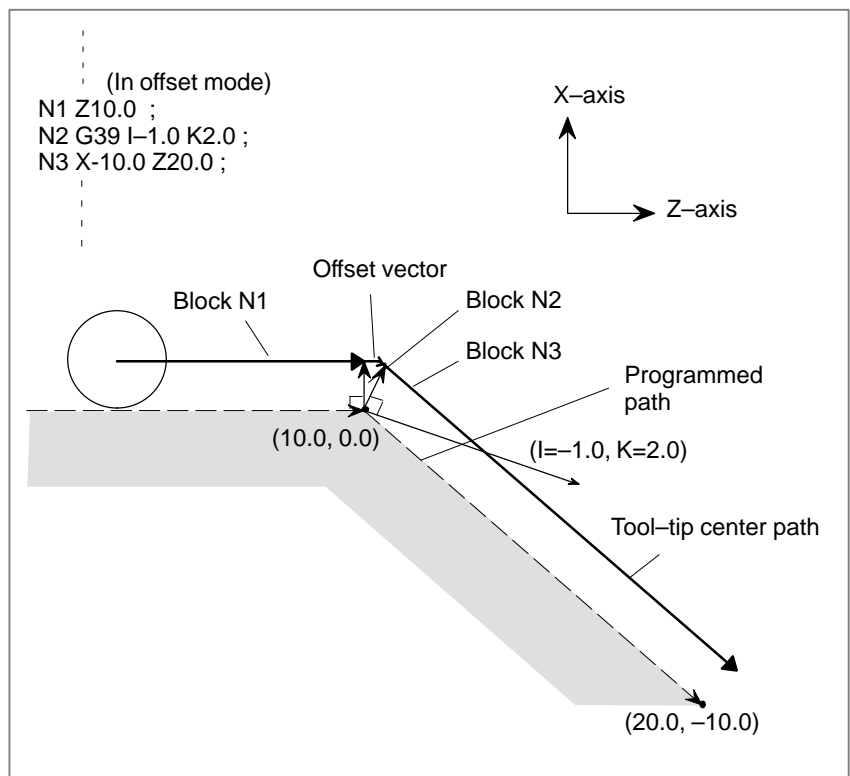

14.5 TOOL COMPENSATION VALUES, NUMBER OF COMPENSATION VALUES, AND ENTERING VALUES FROM THE PROGRAM (G10)

Tool compensation values include tool geometry compensation values and tool wear compensation (Fig. 14.5 (a)). Tool compensation can be specified without differentiating compensation for tool geometry from that for tool wear.

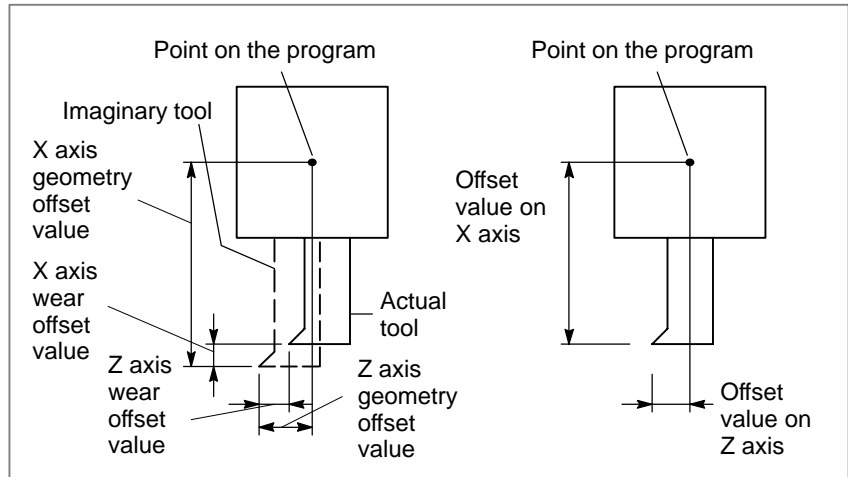

Fig. 14.5 (a) Difference the tool geometry offset from tool wear offset

Fig. 14.5 (b) Not difference the tool geometry offset from tool wear offset

Tool compensation values can be entered into CNC memory from the MDI panel (see section III-9.1) or from a program. A tool compensation value is selected from the CNC memory when the corresponding code is specified after address T in a program. The value is used for tool offset or tool nose radius compensation. See subsec. II-14.1.2 for details.

14.5.1 Tool Compensation and Number of Tool Compensation

- Valid range of tool compensation values

Table 14.5.1 (a) shows the valid input range of tool compensation values.

Table 14.5.1 (a) Valid range of tool compensation values

Increment system	Tool compensation value	
	Metric input (mm)	Inch input (inch)
IS-B	-999.999 to +999.999 mm	-99.9999 to +99.9999 inch
IS-C	-999.9999 to +999.9999 mm	-99.99999 to +99.99999 inch

The maximum tool wear compensation can be changed by setting parameter No. 5013.

- **Seven-digit tool offset specification**

The number of digits used to specify a tool geometry/wear compensation value can be expanded by selecting the option which enables seven-digit tool offset specification. When this option is used, tool compensation values can be specified using up to seven digits for IS-B and eight digits for IS-C. The valid data range for tool compensation values will thus be as listed in Table 14.5.1(b).

Table 14.5.1 (b)

Increment system	Tool compensation value	
	Metric input (mm)	Inch input (inch)
IS-B	0 to ±9999.999 mm	0 to ±999.9999 inch
IS-C	0 to ±9999.9999 mm (0 to ±4000.0000 mm)	0 to ±999.99999 inch (0 to ±160.00000 inch)

NOTE

- 1 The range enclosed in parentheses applies when automatic inch/metric conversion is enabled (bit 0 (OIM) of parameter No. 5006 is set to 1).
- 2 The option enabling seven-digit tool offset specification cannot be used for B-axis offsets for B-axis control.

- **Number of tool compensation**

The memory can hold 16, 32, 64, or 99 tool compensation values.

NOTE

With the two-path control, the number of specified tool compensation values equals the number of tool compensations for each tool post.

14.5.2 Changing of Tool Offset Value (Programmable Data Input) (G10)

Format

Offset values can be input by a program using the following command :

```
G10 P_ X_ Y_ Z_ R_ Q_ ;
```

or

```
G10 P_ U_ V_ W_ C_ Q_ ;
```

P : Offset number

0 : Command of work coordinate system shift value

1-64 : Command of tool wear offset value
Command value is offset number

10000+(1-64) : Command of tool geometry offset value
(1-64) : Offset number

X : Offset value on X axis (absolute)

Y : Offset value on Y axis (absolute)

Z : Offset value on Z axis (absolute)

U : Offset value on X axis (incremental)

V : Offset value on Y axis (incremental)

W : Offset value on Z axis (incremental)

R : Tool nose radius offset value (absolute)

R : Tool nose radius offset value (incremental)

Q : Imaginary tool nose number

In an absolute command, the values specified in addresses X, Y, Z, and R are set as the offset value corresponding to the offset number specified by address P. In an incremental command, the value specified in addresses U, V, W, and C is added to the current offset value corresponding to the offset number.

NOTE

- 1 Addresses X, Y, Z, U, V, and W can be specified in the same block.
- 2 Use of this command in a program allows the tool to advance little by little. This command can also be used input offset values one at a time from a program by specifying this command successively instead of inputting these values one at a time from the MDI unit.

14.6 AUTOMATIC TOOL OFFSET (G36, G37)

When a tool is moved to the measurement position by execution of a command given to the CNC, the CNC automatically measures the difference between the current coordinate value and the coordinate value of the command measurement position and uses it as the offset value for the tool. When the tool has been already offset, it is moved to the measurement position with that offset value. If the CNC judges that further offset is needed after calculating the difference between the coordinate values of the measurement position and the commanded coordinate values, the current offset value is further offset. Refer to the instruction manuals of the machine tool builder for details.

Explanations

- **Coordinate system**

When moving the tool to a position for measurement, the coordinate system must be set in advance. (The work coordinate system for programming is used in common.)

- **Movement to measurement position**

A movement to a measurement position is performed by specifying as follows in the MDI, or MEM mode :

G36 Xx_a ; or G37 Zz_a ;

In this case, the measurement position should be x_a or z_a (absolute command).

Execution of this command moves the tool at the rapid traverse rate toward the measurement position, lowers the feedrate halfway, then continues to move it until the approach end signal from the measuring instrument is issued. When the tool tip reaches the measurement position, the measuring instrument outputs the measurement position reach signal to the CNC which stops the tool.

- **Offset**

The current tool offset value is further offset by the difference between the coordinate value (α or β) when the tool has reached the measurement position and the value of x_a or z_a specified in G36Xx_a or G37Zz_a.

Offset value x = Current offset value x + (α - x_a)

Offset value z = Current offset value z + (β - z_a)

x_a : Programmed X-axis measurement point

z_a : Programmed Z-axis measurement point

These offset values can also be altered from the MDI keyboard.

● **Feedrate and alarm**

The tool, when moving from the starting position toward the measurement position predicted by x_a or z_a in G36 or G37, is fed at the rapid traverse rate across area **A**. Then the tool stops at point T ($x_a - \gamma_x$ or $z_a - \gamma_z$) and moves at the measurement feedrate set by parameter (No. 6241) across areas **B**, **C**, and **D**. If the approach end signal turns on during movement across area **B**, alarm is generated. If the approach end signal does not turn on before point **V**, and tool stops at point **V** and P/S alarm (No. 080) is generated.

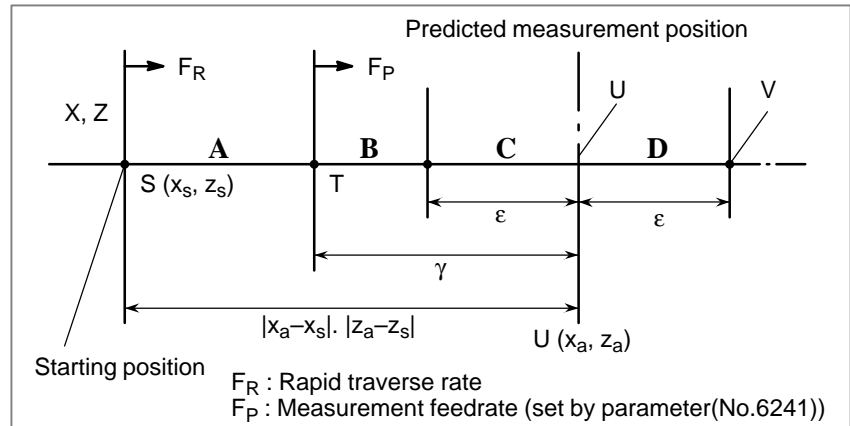
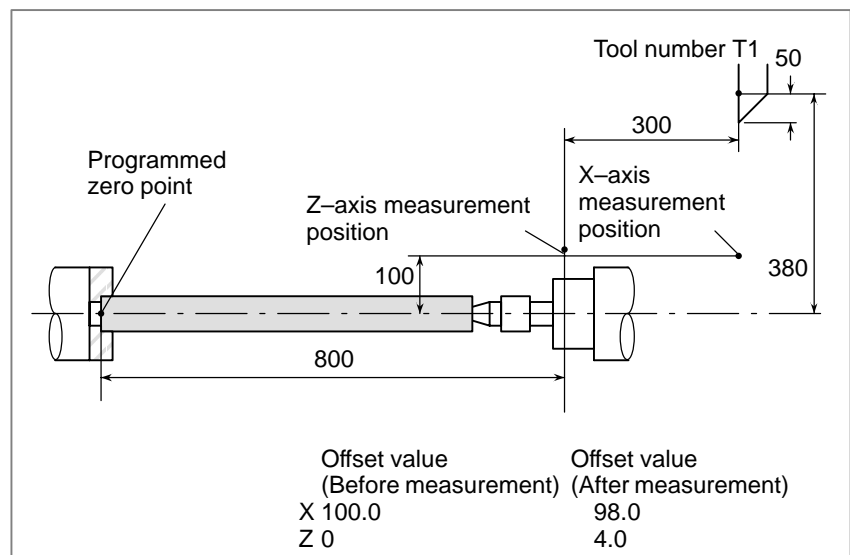

Fig. 14.6 Feedrate and Alarm

● **G code**

If bit 3 (G36) of parameter No. 3405 has been set to 1, G37.1 and G37.2 are used as the G codes for automatic tool compensation for the X- and Z-axes, respectively.

Examples



G50 X760.0 Z1100.0 ; Programming of absolute zero point (Coordinate system setting)

S01 M03 T0101 ; Specifies tool T1, offset number 1, and spindle revolution

G36 X200.0 ;	Moves to the measurement position If the tool has reached the measurement position at X198.0 ; since the correct measurement position is 200 mm, the offset value is altered by $198.0-200.0=-2.0\text{mm}$.
G00 X204.0 ; G37 Z800.0 ;	Refracts a little along the X axis. Moves to the Z-axis measurement position. If the tool has reached the measurement position at X804.0, the offset value is altered by $804.0-800.0=4.0\text{mm}$.
T0101 ;	Further offsets by the difference. The new offset value becomes valid when the T code is specified again.

WARNING

- 1 Measurement speed(Fp), γ , and ε are set as parameters (Fp : No.6241, γ : No.6251, ε : No.6254) by machine tool builder. ε must be positive numbers so that $\gamma > \varepsilon$.
- 2 Cancel the tool nose radius compensation before G36, G37.
- 3 When a manual movement is inserted into a movement at a measurement feedrate, return the tool to the position before the inserted manual movement for restart.
- 4 When using the optional tool nose radius compensation function, the tool offset amount is determined considering the value of tool nose R. Make sure that tool nose radius value is set correctly.

Example) When the tool nose center coincides with the start point.

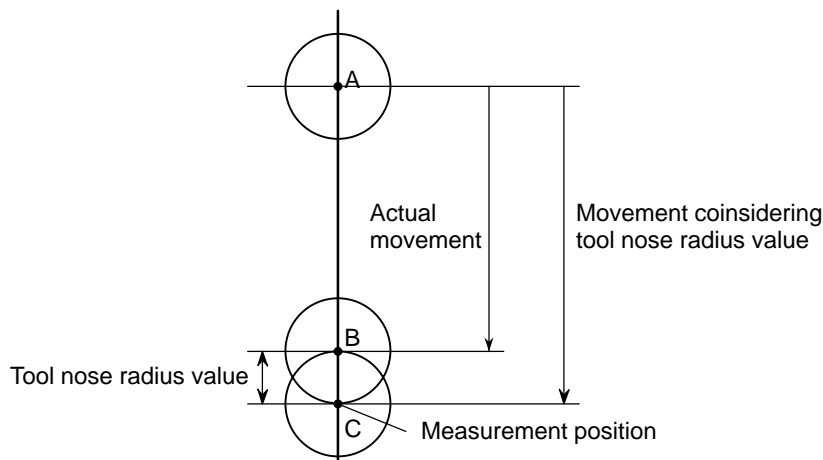

The tool actually moves from point A to point B, but the tool offset value is determined assuming that the tool moves to point C considering the tool nose radius value.

NOTE

- 1 When there is no T code command before G36 or G37, P/S alarm No.81 is generated.
- 2 When a T code is specified in the same block as G36 or G37, P/S alarm No.82 is generated.

14.7 COORDINATE ROTATION (G68.1, G69.1)

With the coordinate rotation function, it is possible to rotate a figure specified in a program. For example, a program that produces patterns of a figure rotated at increasingly larger angles can be created as a pair of subprograms, one of which defines a figure, the other of which calls the figure definition subprogram by specifying rotation. This method is useful for reducing the program development time and the size of the program.

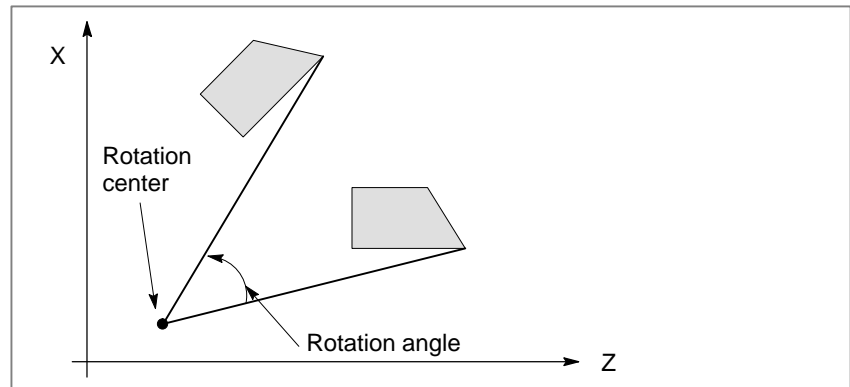

Format

$\left. \begin{matrix} G17 \\ G18 \\ G19 \end{matrix} \right\}$	$G68.1 \ \alpha_ \beta_ R_ ; \text{---}$	Starts rotating the coordinates
\vdots	$\left. \begin{matrix} \vdots \\ \vdots \end{matrix} \right\}$	Coordinate rotation mode (the coordinates are rotated)
	$G69.1 ; \text{---}$	Cancels coordinate rotation

G17 (G18 or G19) :
Selects a plane where the figure to be rotated is

α, β :
Specify two coordinates (from among X, Y, and Z) of the rotation center that match G17, G18, and G19. The values specified as the coordinates of the rotation center must always be absolute values.

R:
Specifies the rotation angle as an absolute value. Counterclockwise rotation is assumed to be positive. However, setting bit 0 (RIN) of parameter No. 5400 enables the use of an incremental value.
Incremental units of the angle: 0.001 degrees
Specifiable range: -360,000 to +360,000

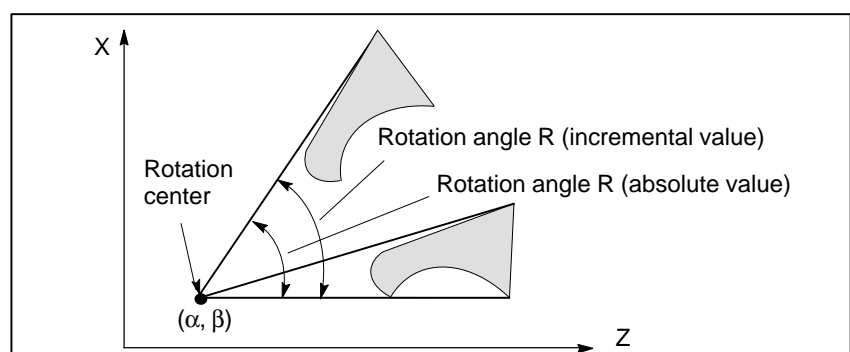

Explanations

- **Plane selection G code, G17, G18, or G19** Plane selection G code (G17, G18, or G19) can be specified in a block ahead of the coordinate rotation G code (G68.1). Do not specify G17, G18, or G19 in coordinate rotation mode.
- **Rotation center** If the rotation center ($\alpha_$, $\beta_$) is not specified, the location of the tool when G68.1 is issued is assumed as the rotation center.
- **Rotation angle command** If the rotation angle command ($R_$) is not specified, the value specified in parameter No. 5410 is used as the rotation angle.
- **Coordinate rotation cancel** The coordinate rotation cancel G code (G69.1) can be specified in the same block as other commands.
- **Tool compensation** Tool compensation, such as tool offset or tool nose radius compensation, is processed after coordinate rotation is performed for a program defining a figure.
G68.1 can be used in either G00 or G01 mode.

Limitations

- **Reference position return** A reference position return command G27, G28, G29, or G30 can be issued only in G69.1 mode.
- **Changes to coordinates** Do not attempt to change coordinates in G68.1 mode (commands such as G50, G54 to G59, and the tool offset command).
- **Canned cycles** Coordinate rotation cannot be used in simple canned cycles, multiple repetitive canned cycles, or canned drilling cycles.
- **Incremental command** Always use absolute values in a move command that immediately follows the coordinate rotation command (G68.1) or coordinate rotation cancel command (G69.1). Specifying an incremental value results in the move command failing to operate normally.

Examples

- **Tool nose radius and coordinate rotation**

G68.1 and G69.1 can be specified during tool nose radius compensation, provided that the coordinate rotation plane coincides with the tool nose radius compensation plane.

```
N1 G50 X0 Z0 G69.1 G01 ;  
N2 G42 X1000 Z1000 F1000 T0101 ;  
N3 G68 R-30000 ;  
N4 Z3000 ;  
N5 G03 U1000 R1000 ;  
N6 G01 Z1000 ;  
N7 U-1000 ;  
N8 G69.1 G40 X0 Z0 ;
```

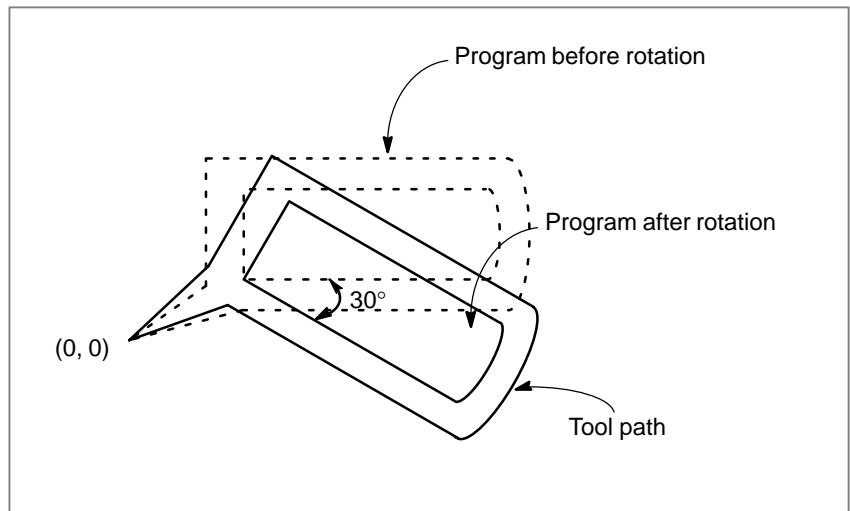

- **Repetitive coordinate rotation**

Coordinate rotation can be repeated by calling a registered subprogram more than once, but with increasingly greater rotation angles.

Set bit 0 (RIN) of parameter No. 5400 to 1 to specify the rotation angle as being incremental. (G code A, radius programming along the X-axis)

```
G50 X0 Z0 G18 ;
G01 F200 T0101 ;
M98 P2100 ;
M98 P2200 L7 ;
G00 X0 Z0 M30 ;
```

```
O2200 ;
G68.1 X0 Z0 R45.0 ;
G90 M98 P2100 ;
M99 ;
O2100 ;
G01 G42 X-10.0 Z0 ;
X-10.0 Z4.142 ;
X-7.071 Z7.071 ;
G40 M99 ;
```

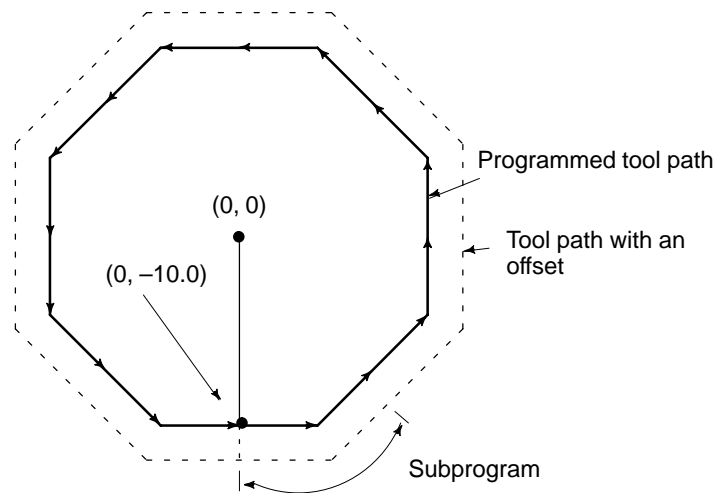

15 CUSTOM MACRO

Although subprograms are useful for repeating the same operation, the custom macro function also allows use of variables, arithmetic and logic operations, and conditional branches for easy development of general programs such as pocketing and user-defined canned cycles. A machining program can call a custom macro with a simple command, just like a subprogram.

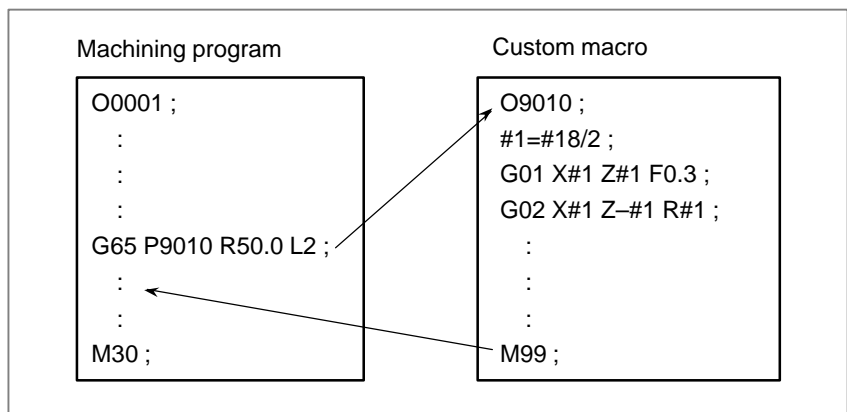

15.1 VARIABLES

An ordinary machining program specifies a G code and the travel distance directly with a numeric value; examples are G100 and X100.0.

With a custom macro, numeric values can be specified directly or using a variable number. When a variable number is used, the variable value can be changed by a program or using operations on the MDI panel.

```
#1=#2+100 ;
G01 X#1 F0.3 ;
```

Explanation

- **Variable representation**

When specifying a variable, specify a number sign (#) followed by a variable number. General-purpose programming languages allow a name to be assigned to a variable, but this capability is not available for custom macros.

Example: #1

An expression can be used to specify a variable number. In such a case, the expression must be enclosed in brackets.

Example: #[#1+#2-12]

- **Types of variables**

Variables are classified into four types by variable number.

Table 15.1 Types of variables

Variable number	Type of variable	Function
#0	Always null	This variable is always null. No value can be assigned to this variable.
#1 – #33	Local variables	Local variables can only be used within a macro to hold data such as the results of operations. When the power is turned off, local variables are initialized to null. When a macro is called, arguments are assigned to local variables.
#100 – #149 (#199) #500 – #531 (#999)	Common variables	Common variables can be shared among different macro programs. When the power is turned off, variables #100 to #149 are initialized to null. Variables #500 to #531 hold data even when the power is turned off. As an option, common variables #150 to #199 and #532 to #999 are also available. However, when these values are using, the length of the tape that can be used for storage decreases by 8.5 m.
#1000 or later	System variables	System variables are used to read and write a variety of NC data items such as the current position and tool compensation values.

NOTE

Common variables #150 to #199 and #532 to #999 are optional.

● **Range of variable values**

Local and common variables can have value 0 or a value in the following ranges :

-10^{47} to -10^{-29}

0

$+10^{-29}$ to $+10^{47}$

If the result of calculation turns out to be invalid, an P/S alarm No. 111 is issued.

● **Omission of the decimal point**

When a variable value is defined in a program, the decimal point can be omitted.

Example:

When #1=123; is defined, the actual value of variable #1 is 123.000.

● **Referencing variables**

To reference the value of a variable in a program, specify a word address followed by the variable number. When an expression is used to specify a variable, enclose the expression in brackets.

Example: G01X[#1+#2]F#3;

A referenced variable value is automatically rounded according to the least input increment of the address.

Example:

When G00X#1; is executed on a 1/1000–mm CNC with 12.3456 assigned to variable #1, the actual command is interpreted as G00X12.346;.

To reverse the sign of a referenced variable value, prefix a minus sign (–) to #.

Example: G00X–#1;

When an undefined variable is referenced, the variable is ignored up to an address word.

Example:

When the value of variable #1 is 0, and the value of variable #2 is null, execution of G00X#1Z#2; results in G00X0;.

● **Undefined variable**

When the value of a variable is not defined, such a variable is referred to as a "null" variable. Variable #0 is always a null variable. It cannot be written to, but it can be read.

(a) Quotation

When an undefined variable is quoted, the address itself is also ignored.

When #1 = < vacant >	When #1 = 0
G90 X100 Y#1	G90 X100 Y#1
↓	↓
G90 X100	G90 X100 Y0

(b) Operation

< vacant > is the same as 0 except when replaced by < vacant >

When #1 = < vacant >	When #1 = 0
#2 = #1 ↓ #2 = < vacant >	#2 = #1 ↓ #2 = 0
#2 = #1*5 ↓ #2 = 0	#2 = #1*5 ↓ #2 = 0
#2 = #1+#1 ↓ #2 = 0	#2 = #1 + #1 ↓ #2 = 0

(c) Conditional expressions

< vacant > differs from 0 only for EQ and NE.

When #1 = < vacant >	When #1 = 0
#1 EQ #0 ↓ Established	#1 EQ #0 ↓ Not established
#1 NE 0 ↓ Established	#1 NE 0 ↓ Not established
#1 GE #0 ↓ Established	#1 GE #0 ↓ Established
#1 GT 0 ↓ Not established	#1 GT 0 ↓ Not established

- **Custom macro variables common to tool posts (two-path control)**

With the two-path control, macro variables are provided for each tool post. Specifying parameter Nos. 6036 and 6037 allows some of the common variables to be used for all tool posts.

● Displaying variable values

```

VARIABLE
NO.          DATA          NO.          O1234 N12345
              DATA
100 123.456108
101 0.000 109
102 110
103 ***** 111
104 112
105 113
106 114
107          115

ACTUAL POSITION (RELATIVE)
X          0.000          Y          0.000
Z          0.000          B          0.000

MEM ***** 18:42:15

[ MACRO ] [ MENU ] [ OPR ] [ ] [ (OPRT) ]

```

- When the value of a variable is blank, the variable is null.
- The mark ********* indicates an overflow (when the absolute value of a variable is greater than 99999999) or an underflow (when the absolute value of a variable is less than 0.0000001).

Limitations

Program numbers, sequence numbers, and optional block skip numbers cannot be referenced using variables.

Example:

Variables cannot be used in the following ways:

O#1;

/#2G00X100.0;

N#3Z200.0;

15.2 SYSTEM VARIABLES

System variables can be used to read and write internal NC data such as tool compensation values and current position data. Note, however, that some system variables can only be read. System variables are essential for automation and general-purpose program development.

Explanations

- **Interface signals**

Signals can be exchanged between the programmable machine controller (PMC) and custom macros.

Table 15.2 (a) System variables for interface signals

Variable number	Function
#1000–#1015 #1032	A 16-bit signal can be sent from the PMC to a custom macro. Variables #1000 to #1015 are used to read a signal bit by bit. Variable #1032 is used to read all 16 bits of a signal at one time.
#1100–#1115 #1132	A 16-bit signal can be sent from a custom macro to the PMC. Variables #1100 to #1115 are used to write a signal bit by bit. Variable #1132 is used to write all 16 bits of a signal at one time.
#1133	Variable #1133 is used to write all 32 bits of a signal at one time from a custom macro to the PMC. Note, that values from -99999999 to +99999999 can be used for #1133.

For detailed information, refer to the connection manual (B-63523EN-1).

- **Tool compensation values**

When the system does not differentiate tool geometry compensation from tool wear compensation, use variable numbers for wear compensation.

Table 15.2 (b) System variables for tool compensation memory C

Compensation number	X axis compensation value		Z axis compensation value		Tool nose radius compensation value		Imaginary tool nose position T	Y axis compensation value	
	Wear	Geometry	Wear	Geometry	Wear	Geometry		Wear	Geometry
1 ⋮ 49 ⋮ 64	#2001 ⋮ ⋮ ⋮ #2064	#2701 ⋮ #2749	#2101 ⋮ ⋮ ⋮ #2164	#2801 ⋮ #2849	#2201 ⋮ ⋮ ⋮ #2264	#2901 ⋮ ⋮ ⋮ #2964	#2301 ⋮ ⋮ ⋮ #2364	#2401 ⋮ #2449	#2451 ⋮ #2499

Table 15.2 (c) System variables for 99 tool compensation values

Compensation number	X axis compensation value		Z axis compensation value		Tool nose radius compensation value		Imaginary tool nose position T	Y axis compensation value	
	Wear	Geometry	Wear	Geometry	Wear	Geometry		Wear	Geometry
1 ⋮ 99	#10001 ⋮ ⋮ #10099	#15001 ⋮ ⋮ #15099	#11001 ⋮ ⋮ #11099	#16001 ⋮ ⋮ #16099	#12001 ⋮ ⋮ #12099	#17001 ⋮ ⋮ #17099	#13001 ⋮ ⋮ #13099	#14001 ⋮ ⋮ #14099	#19001 ⋮ ⋮ #19099

Workpiece coordinate system shift amount

A workpiece coordinate system shift amount can be read. The amount can also be changed by entering a value.

Controlled axis	Workpiece coordinate system shift amount
X axis	#2501
Z axis	#2601

• Macro alarms

Table 15.2 (d) System variable for macro alarms

Variable number	Function
#3000	When a value from 0 to 200 is assigned to variable #3000, the CNC stops with an alarm. After an expression, an alarm message not longer than 26 characters can be described. The CRT screen displays alarm numbers by adding 3000 to the value in variable #3000 along with an alarm message.

Example:

#3000=1(TOOL NOT FOUND);

→ **The alarm screen displays “3001 TOOL NOT FOUND.”**

• Time information

Time information can be read and written.

Table 15.2 (e) System variables for time information

Variable number	Function
#3001	This variable functions as a timer that counts in 1–millisecond increments at all times. When the power is turned on, the value of this variable is reset to 0. When 2147483648 milliseconds is reached, the value of this timer returns to 0.
#3002	This variable functions as a timer that counts in 1–hour increments when the cycle start lamp is on. This timer preserves its value even when the power is turned off. When 9544.371767 hours is reached, the value of this timer returns to 0.
#3011	This variable can be used to read the current date (year/month/day). Year/month/day information is converted to an apparent decimal number. For example, March 28, 1993 is represented as 19930328.
#3012	This variable can be used to read the current time (hours/minutes/seconds). Hours/minutes/seconds information is converted to an apparent decimal number. For example, 34 minutes and 56 seconds after 3 p.m. is represented as 153456.

- **Automatic operation control**

The control state of automatic operation can be changed.

Table 15.2 (f) System variable (#3003) for automatic operation control

#3003	Single block	Completion of an auxiliary function
0	Enabled	To be awaited
1	Disabled	To be awaited
2	Enabled	Not to be awaited
3	Disabled	Not to be awaited

- When the power is turned on, the value of this variable is 0.
- When single block stop is disabled, single block stop operation is not performed even if the single block switch is set to ON.
- When a wait for the completion of auxiliary functions (M, S, and T functions) is not specified, program execution proceeds to the next block before completion of auxiliary functions. Also, distribution completion signal DEN is not output.

Table 15.2 (g) System variable (#3004) for automatic operation control

#3004	Feed hold	Feedrate Override	Exact stop
0	Enabled	Enabled	Enabled
1	Disabled	Enabled	Enabled
2	Enabled	Disabled	Enabled
3	Disabled	Disabled	Enabled
4	Enabled	Enabled	Disabled
5	Disabled	Enabled	Disabled
6	Enabled	Disabled	Disabled
7	Disabled	Disabled	Disabled

- When the power is turned on, the value of this variable is 0.
- When feed hold is disabled:
 - (1) When the feed hold button is held down, the machine stops in the single block stop mode. However, single block stop operation is not performed when the single block mode is disabled with variable #3003.
 - (2) When the feed hold button is pressed then released, the feed hold lamp comes on, but the machine does not stop; program execution continues and the machine stops at the first block where feed hold is enabled.
- When feedrate override is disabled, an override of 100% is always applied regardless of the setting of the feedrate override switch on the machine operator's panel.
- When exact stop check is disabled, no exact stop check (position check) is made even in blocks including those which do not perform cutting.

● **Settings**

Settings can be read and written. Binary values are converted to decimals.

#3005								
Setting	#15	#14	#13	#12	#11	#10	#9	#8
							FCV	
Setting	#7	#6	#5	#4	#3	#2	#1	#0
			SEQ			INI	ISO	TVC

#9 (FCV) : Whether to use the FS15 tape format conversion capability
 #5 (SEQ) : Whether to automatically insert sequence numbers
 #2 (INI) : Millimeter input or inch input
 #1 (ISO) : Whether to use EIA or ISO as the output code
 #0 (TVC) : Whether to make a TV check

● **Stop with a message**

Execution of the program can be stopped, and then a message can be displayed.

Variable number	Function
#3006	When "#3006=1 (MESSAGE);" is commanded in the macro, the program executes blocks up to the immediately previous one and then stops. When a message of up to 26 characters, which is enclosed by a control-in character ("(") and control-out character (")"), is programmed in the same block, the message is displayed on the external operator message screen.

● **Mirror image**

The mirror-image status for each axis set using an external switch or setting operation can be read through the output signal (mirror-image check signal). The mirror-image status present at that time can be checked. (See Section 4.7 in III.)

The value obtained in binary is converted into decimal notation.

#3007								
Setting	#7	#6	#5	#4	#3	#2	#1	#0
	8th axis	7th axis	6th axis	5th axis	4th axis	3th axis	2th axis	1th axis

For each bit, $\left[\begin{array}{l} 0 \text{ (mirror-image function is disabled)} \\ \text{or} \\ 1 \text{ (mirror-image function is enabled)} \end{array} \right]$ is indicated.

Example : If #3007 is 3, the mirror-image function is enabled for the first and second axes.

- When the mirror-image function is set for a certain axis by both the mirror-image signal and setting, the signal value and setting value are ORed and then output.
- When mirror-image signals for axes other than the controlled axes are turned on, they are still read into system variable #3007.
- System variable #3007 is a write-protected system variable. If an attempt is made to write data in the variable, P/S 116 alarm "WRITE PROTECTED VARIABLE" is issued.

● **Number of machined parts**

The number (target number) of parts required and the number (completion number) of machined parts can be read and written.

Table 15.2 (h) System variables for the number of parts required and the number of machined parts

Variable number	Function
#3901	Number of machined parts (completion number)
#3902	Number of required parts (target number)

NOTE

Do not substitute a negative value.

● **Modal information**

Modal information specified in blocks up to the immediately preceding block can be read.

Table 15.2 (i) System variables for modal information

Variable number	Function
#4001	G00, G01, G02, G03, G33, G34 (Group 01)
#4002	G96, G97 (Group 02)
#4003	(Group 03)
#4004	G68, G69 (Group 04)
#4005	G98, G99 (Group 05)
#4006	G20, G21 (Group 06)
#4007	G40, G41, G42 (Group 07)
#4008	G25, G26 (Group 08)
#4009	G22, G23 (Group 09)
#4010	G80 – G89 (Group 10)
#4011	(Group 11)
#4012	G66, G67 (Group 12)
#4014	G54–G59 (Group 14)
#4015	(Group 15)
#4016	G17 – G19 (Group 16)
:	:
#4022	(Group 22)
#4109	F code
#4113	M code
#4114	Sequence number
#4115	Program number
#4119	S code
#4120	T code

Example:

When #1=#4001; is executed, the resulting value in #1 is 0, 1, 2, 3, or 33.

When a modal information reading system variable corresponding to a G code group which cannot be used is specified, a P/S alarm is issued.

- **Current position**

Position information cannot be written but can be read.

Table 15.2 (j) System variables for position information

Variable number	Position information	Coordinate system	Tool compensation value	Read operation during movement
#5001–#5008	Block end point	Workpiece coordinate system	Not included	Enabled
#5021–#5028	Current position	Machine coordinate system	Included	Disabled
#5041–#5048	Current position	Workpiece coordinate system		
#5061–#5068	Skip signal position			Enabled
#5081, #5082	Tool offset value			Disabled
#5101–#5108	Deviated servo position			

- The first digit (from 1 to 8) represents an axis number.
- The tool offset value currently used for execution rather than the immediately preceding tool offset value is held in variables #5081 to 5088.
- The tool position where the skip signal is turned on in a G31 (skip function) block is held in variables #5061 to #5068. When the skip signal is not turned on in a G31 block, the end point of the specified block is held in these variables.
- When read during movement is “disabled,” this means that expected values cannot be read due to the buffering (preread) function.

- **Workpiece coordinate system compensation values (workpiece zero point offset values)**

Workpiece zero point offset values can be read and written.

Table 15.2 (k) System variables for workpiece zero point offset values

Variable number	Function
#5201 : #5208	First-axis external workpiece zero point offset value : Eighth-axis external workpiece zero point offset value
#5221 : #5228	First-axis G54 workpiece zero point offset value : Eighth-axis G54 workpiece zero point offset value
#5241 : #5248	First-axis G55 workpiece zero point offset value : Eighth-axis G55 workpiece zero point offset value
#5261 : #5268	First-axis G56 workpiece zero point offset value : Eighth-axis G56 workpiece zero point offset value
#5281 : #5288	First-axis G57 workpiece zero point offset value : Eighth-axis G57 workpiece zero point offset value
#5301 : #5308	First-axis G58 workpiece zero point offset value : Eighth-axis G58 workpiece zero point offset value
#5321 : #5328	First-axis G59 workpiece zero point offset value : Eighth-axis G59 workpiece zero point offset value

NOTE

To use variables #5201 to #5328, the workpiece coordinate system option is necessary.

15.3 ARITHMETIC AND LOGIC OPERATION

The operations listed in Table 15.3 (a) can be performed on variables. The expression to the right of the operator can contain constants and/or variables combined by a function or operator. Variables #j and #K in an expression can be replaced with a constant. Variables on the left can also be replaced with an expression.

Table 15.3 (a) Arithmetic and logic operation

Function	Format	Remarks
Definition	#i=#j	
Sum	#i=#j+#k;	
Difference	#i=#j-#k;	
Product	#i=#j*#k;	
Quotient	#i=#j/#k;	
Sine	#i=SIN[#j];	An angle is specified in degrees. 90 degrees and 30 minutes is represented as 90.5 degrees.
Arc sine	#i=ASIN[#j];	
Cosine	#i=COS[#j];	
Arc cosine	#i=ACOS[#j];	
Tangent	#i=TAN[#j];	
Arctangent	#i=ATAN[#j]/[#k];	
Square root	#i=SQRT[#j];	
Absolute value	#i=ABS[#j];	
Rounding off	#i=ROUND[#j];	
Rounding down	#i=FIX[#j];	
Rounding up	#i=FUP[#j];	
Natural logarithm	#i=LN[#j]	
Exponential function	#i=EXP[#j];	
OR	#i=#j OR #k;	A logical operation is performed on binary numbers bit by bit.
XOR	#i=#j XOR #k;	
AND	#i=#j AND #k;	
Conversion from BCD to BIN	#i=BIN[#j];	Used for signal exchange to and from the PMC
Conversion from BIN to BCD	#i=BCD[#j];	

Explanations

- **Angle units**

The units of angles used with the SIN, COS, TAN, ASIN, ACOS and ATAN functions are degrees. For example, 90 degrees and 30 minutes is represented as 90.5 degrees.

- **ARCSIN #i = ASIN[#j];**

- The solution ranges are as indicated below:
 - When the NAT bit (bit 0 of parameter 6004) is set to 0: 270° to 90°
 - When the NAT bit (bit 0 of parameter 6004) is set to 1: -90° to 90°
- When #j is beyond the range of -1 to 1, P/S alarm No. 111 is issued.
- A constant can be used instead of the #j variable.

- **ARCCOS #i = ACOS[#j];**
 - The solution ranges from 180° to 0°.
 - When #j is beyond the range of -1 to 1, P/S alarm No. 111 is issued.
 - A constant can be used instead of the #j variable.
- **ARCTAN**
#i = ATAN[#j]/[#k];
 - Specify the lengths of two sides, separated by a slash (/).
 - The solution ranges are as follows:
When the NAT bit (bit 0 of parameter 6004) is set to 0: 0° to 360°

Example:

When #1 = ATAN[-1]/[-1]; is specified, #1 is 225.0

When the NAT bit (bit 0 of parameter 6004) is set to 1: -180° to 180°

Example:

When #1 = ATAN[-1]/[-1]; is specified, #1 is -135.0.

- **Natural logarithm**
#i = LN[#j];
 - A constant can be used instead of the #j variable.
 - Note that the relative error may become 10⁻⁸ or greater.
 - When the antilogarithm (#j) is zero or smaller, P/S alarm No. 111 is issued.
 - A constant can be used instead of the #j variable.
- **Exponential function**
#i = EXP[#j];
 - Note that the relative error may become 10⁻⁸ or greater.
 - When the result of the operation exceeds 3.65 × 10⁴⁷ (j is about 110), an overflow occurs and P/S alarm No. 111 is issued.
 - A constant can be used instead of the #j variable.
- **ROUND function**
 - When the ROUND function is included in an arithmetic or logic operation command, IF statement, or WHILE statement, the ROUND function rounds off at the first decimal place.

Example:

When #1=ROUND[#2]; is executed where #2 holds 1.2345, the value of variable #1 is 1.0.

- When the ROUND function is used in NC statement addresses, the ROUND function rounds off the specified value according to the least input increment of the address.

Example:

Creation of a drilling program that cuts according to the values of variables #1 and #2, then returns to the original position

Suppose that the increment system is 1/1000 mm, variable #1 holds 1.2345, and variable #2 holds 2.3456. Then,

G00 G91 X-#1; Moves 1.235 mm.

G01 X-#2 F300; Moves 2.346 mm.

G00 X[#1+#2];

Since 1.2345 + 2.3456 = 3.5801, the travel distance is 3.580, which does not return the tool to the original position.

This difference comes from whether addition is performed before or after rounding off. G00X-[ROUND[#1]+ROUND[#2]] must be specified to return the tool to the original position.

- **Rounding up and down to an integer**

With CNC, when the absolute value of the integer produced by an operation on a number is greater than the absolute value of the original number, such an operation is referred to as rounding up to an integer. Conversely, when the absolute value of the integer produced by an operation on a number is less than the absolute value of the original number, such an operation is referred to as rounding down to an integer. Be particularly careful when handling negative numbers.

Example:

Suppose that #1=1.2 and #2=-1.2.

When #3=FUP[#1] is executed, 2.0 is assigned to #3.

When #3=FIX[#1] is executed, 1.0 is assigned to #3.

When #3=FUP[#2] is executed, -2.0 is assigned to #3.

When #3=FIX[#2] is executed, -1.0 is assigned to #3.

- **Abbreviations of arithmetic and logic operation commands**

When a function is specified in a program, the first two characters of the function name can be used to specify the function. (See III-9.7)

Example:

ROUND → RO

FIX → FI

- **Priority of operations**

(1) Functions

(2) Operations such as multiplication and division (*, /, AND, MOD)

(3) Operations such as addition and subtraction (+, -, OR, XOR)

Example) #1=#2+#3*SIN[#4];

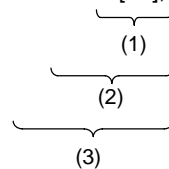

(1), (2), and (3) indicate the order of operations.

- **Bracket nesting**

Brackets are used to change the order of operations. Brackets can be used to a depth of five levels including the brackets used to enclose a function. When a depth of five levels is exceeded, alarm No. 118 occurs.

Example) #1=SIN [[[#2+#3] *#4 +#5] *#6] ;

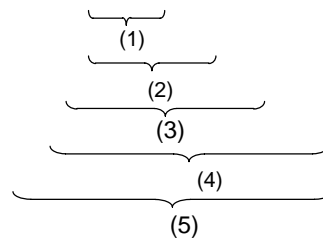

(1) to (5) indicate the order of operations.

Limitations

- **Brackets**

Brackets ([,]) are used to enclose an expression. Note that parentheses are used for comments.

• **Operation error**

Errors may occur when operations are performed.

Table 15.3 (b) Errors involved in operations

Operation	Average error	Maximum error	Type of error
a = b*c	1.55×10 ⁻¹⁰	4.66×10 ⁻¹⁰	Relative error(*1) $\left \frac{\epsilon}{b} \right $
a = b / c	4.66×10 ⁻¹⁰	1.88×10 ⁻⁹	
a = √b	1.24×10 ⁻⁹	3.73×10 ⁻⁹	
a = b + c a = b - c	2.33×10 ⁻¹⁰	5.32×10 ⁻¹⁰	Min $\left \frac{\epsilon}{b} \right \left \frac{\epsilon}{c} \right $ (*2)
a = SIN [b] a = COS [b]	5.0×10 ⁻⁹	1.0×10 ⁻⁸	Absolute error(*3) $\left \epsilon \right $ degrees
a = ATAN [b] / [c] (*4)	1.8×10 ⁻⁶	3.6×10 ⁻⁶	

NOTE

- 1 The relative error depends on the result of the operation.
- 2 Smaller of the two types of errors is used.
- 3 The absolute error is constant, regardless of the result of the operation.
- 4 Function TAN performs SIN/COS.

- The precision of variable values is about 8 decimal digits. When very large numbers are handled in an addition or subtraction, the expected results may not be obtained.

Example:

When an attempt is made to assign the following values to variables #1 and #2:

#1=9876543210123.456

#2=9876543277777.777

the values of the variables become:

#1=9876543200000.000

#2=9876543300000.000

In this case, when #3=#2-#1; is calculated, #3=100000.000 results. (The actual result of this calculation is slightly different because it is performed in binary.)

- Also be aware of errors that can result from conditional expressions using EQ, NE, GE, GT, LE, and LT.

Example:

IF [#1 EQ #2] is effected by errors in both #1 and #2, possibly resulting in an incorrect decision.

Therefore, instead find the difference between the two variables with IF[ABS[#1-#2]LT0.001].

Then, assume that the values of the two variables are equal when the difference does not exceed an allowable limit (0.001 in this case).

- Also, be careful when rounding down a value.

Example:

When $\#2=\#1*1000$; is calculated where $\#1=0.002$;, the resulting value of variable $\#2$ is not exactly 2 but 1.99999997.

Here, when $\#3=FIX[\#2]$; is specified, the resulting value of variable $\#1$ is not 2.0 but 1.0. In this case, round down the value after correcting the error so that the result is greater than the expected number, or round it off as follows:

$\#3=FIX[\#2+0.001]$

$\#3=ROUND[\#2]$

- **Divisor**

When a divisor of zero is specified in a division or TAN[90], alarm No. 112 occurs.

15.4 MACRO STATEMENTS AND NC STATEMENTS

The following blocks are referred to as macro statements:

- **Blocks containing an arithmetic or logic operation (=)**
- **Blocks containing a control statement (such as GOTO, DO, END)**
- **Blocks containing a macro call command (such as macro calls by G65, G66, G67, or other G codes, or by M codes)**

Any block other than a macro statement is referred to as an NC statement.

Explanations

- **Differences from NC statements**
- **NC statements that have the same property as macro statements**

- Even when single block mode is on, the machine does not stop. Note, however, that the machine stops in the single block mode when bit 5 (SBM) of parameter 6000 is 1.

- Macro blocks are not regarded as blocks that involve no movement in the tool nose radius compensation mode (see Section II-15.7).

When parameter NPS (No. 3450#4) is set to 1, the NC statements in a block satisfying the following conditions are equivalent to macro statements.

- If a block contains a subprogram call command (M98, a subprogram call using an M code, or a subprogram call using a T code) and does not contain any command address other than O, N, P, or L, that block is equivalent to a macro statement.
- If a block contains M99 and does not contain any command address other than O, N, P, or L, that block is equivalent to a macro statement.

15.5 BRANCH AND REPETITION

In a program, the flow of control can be changed using the GOTO statement and IF statement. Three types of branch and repetition operations are used:

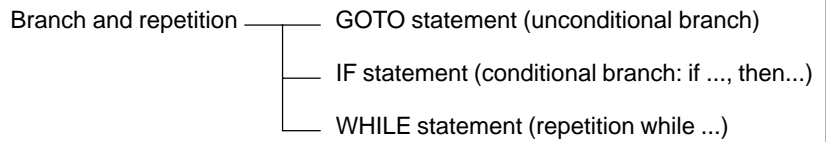

15.5.1 Unconditional Branch (GOTO Statement)

A branch to sequence number n occurs. When a sequence number outside of the range 1 to 99999 is specified, P/S alarm No. 128 occurs. A sequence number can also be specified using an expression.

GOTO n; n: Sequence number (1 to 99999)
--

Example:

GOTO1;
GOTO#10;

15.5.2 Conditional Branch (IF Statement)

Specify a conditional expression after IF. IF [<conditional expression>] GOTO n If the specified conditional expression is satisfied, a branch to sequence number n occurs. If the specified condition is not satisfied, the next block is executed.

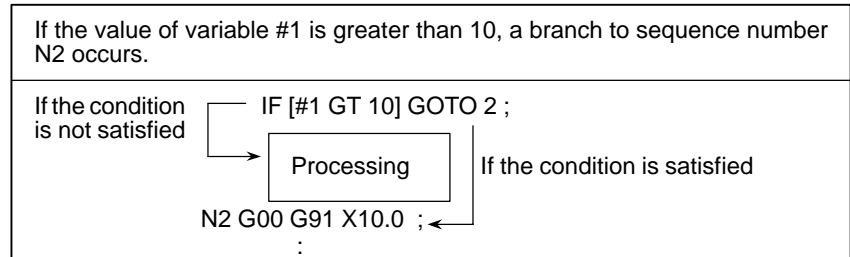

IF[<conditional expression>]THEN

If the specified conditional expression is satisfied, a predetermined macro statement is executed. Only a single macro statement is executed.

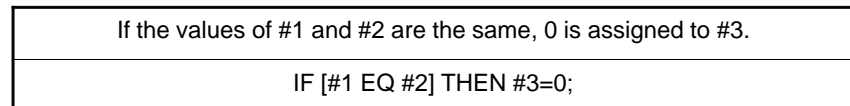

Explanations

- **Conditional expression**

- **Operators**

A conditional expression must include an operator inserted between two variables or between a variable and constant, and must be enclosed in brackets ([,]). An expression can be used instead of a variable.

Operators each consist of two letters and are used to compare two values to determine whether they are equal or one value is smaller or greater than the other value. Note that the inequality sign cannot be used.

Table 15.5.2 Operators

Operator	Meaning
EQ	Equal to(=)
NE	Not equal to(≠)
GT	Greater than(>)
GE	Greater than or equal to(≥)
LT	Less than(<)
LE	Less than or equal to(≤)

Sample program

The sample program below finds the total of numbers 1 to 10.

<pre>O9500; #1=0;Initial value of the variable to hold the sum #2=1;Initial value of the variable as an addend N1 IF[#2 GT 10] GOTO 2; . Branch to N2 when the addend is greater than 10 #1=#1+#2; Calculation to find the sum #2=#2+1; Next addend GOTO 1; Branch to N1 N2 M30;End of program</pre>
--

15.5.3 Repetition (While Statement)

Specify a conditional expression after WHILE. While the specified condition is satisfied, the program from DO to END is executed. If the specified condition is not satisfied, program execution proceeds to the block after END.

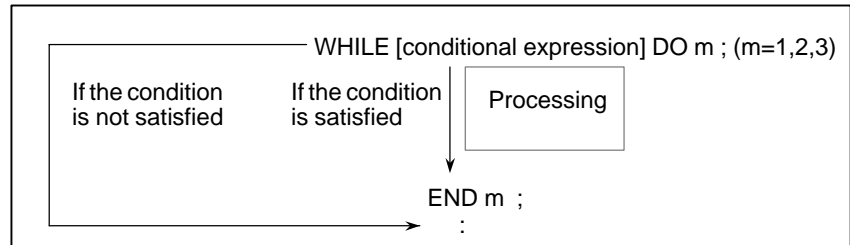

Explanations

While the specified condition is satisfied, the program from DO to END after WHILE is executed. If the specified condition is not satisfied, program execution proceeds to the block after END. The same format as for the IF statement applies. A number after DO and a number after END are identification numbers for specifying the range of execution. The numbers 1, 2, and 3 can be used. When a number other than 1, 2, and 3 is used, P/S alarm No. 126 occurs.

• **Nesting**

The identification numbers (1 to 3) in a DO-END loop can be used as many times as desired. Note, however, when a program includes crossing repetition loops (overlapped DO ranges), P/S alarm No. 124 occurs.

<p>1. The identification numbers (1 to 3) can be used as many times as required.</p> <pre> WHILE [...] DO 1 ; Processing END 1 ; : WHILE [...] DO 1 ; Processing END 1 ; </pre> <p>2. DO ranges cannot overlap.</p> <pre> WHILE [...] DO 1 ; Processing WHILE [...] DO 2 ; : Processing END 2 ; </pre>	<p>3. DO loops can be nested to a maximum depth of three levels.</p> <pre> WHILE [...] DO 1 ; : WHILE [...] DO 2 ; : WHILE [...] DO 3 ; Processing END 3 ; END 2 ; : END 1 ; </pre> <p>4. Control can be transferred to the outside of a loop.</p> <pre> WHILE [...] DO 1 ; IF [...] GOTO n ; : END 1 ; : Nn </pre> <p>5. Branches cannot be made to a location within a loop.</p> <pre> IF [...] GOTO n ; : WHILE [...] DO 1 ; : Nn ... ; : END 1 ; </pre>
--	---

Limitations

• **Infinite loops**

When DO m is specified without specifying the WHILE statement, an infinite loop ranging from DO to END is produced.

• **Processing time**

When a branch to the sequence number specified in a GOTO statement occurs, the sequence number is searched for. For this reason, processing in the reverse direction takes a longer time than processing in the forward direction. Using the WHILE statement for repetition reduces processing time.

• **Undefined variable**

In a conditional expression that uses EQ or NE, a null value and zero have different effects. In other types of conditional expressions, a null value is regarded as zero.

Sample program

The sample program below finds the total of numbers 1 to 10.

```
O0001;  
#1=0;  
#2=1;  
WHILE[#2 LE 10]DO 1;  
#1=#1+#2;  
#2=#2+1;  
END 1;  
M30;
```

15.6 MACRO CALL

A macro program can be called using the following methods:

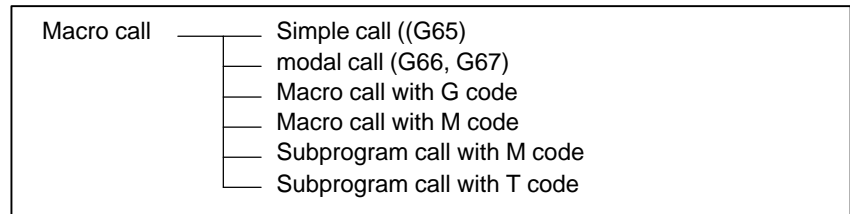

Restrictions

- **Differences between macro calls and subprogram calls**

Macro call (G65) differs from subprogram call (M98) as described below.

- With G65, an argument (data passed to a macro) can be specified. M98 does not have this capability.
- When an M98 block contains another NC command (for example, G01 X100.0 M98Pp), the subprogram is called after the command is executed. On the other hand, G65 unconditionally calls a macro.
- When an M98 block contains another NC command (for example, G01 X100.0 M98Pp), the machine stops in the single block mode. On the other hand, G65 does not stop the machine.
- With G65, the level of local variables changes. With M98, the level of local variables does not change.

15.6.1 Simple Call (G65)

When G65 is specified, the custom macro specified at address P is called. Data (argument) can be passed to the custom macro program.

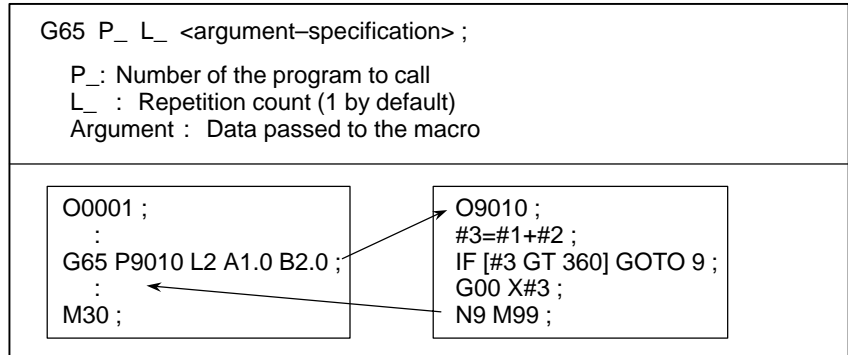

Explanations

• Call

- After G65, specify at address P the program number of the custom macro to call.
- When a number of repetitions is required, specify a number from 1 to 9999 after address L. When L is omitted, 1 is assumed.
- By using argument specification, values are assigned to corresponding local variables.

• Argument specification

Two types of argument specification are available. Argument specification I uses letters other than G, L, O, N, and P once each. Argument specification II uses A, B, and C once each and also uses I, J, and K up to ten times. The type of argument specification is determined automatically according to the letters used.

Argument specification I

Address	Variable number
A	#1
B	#2
C	#3
D	#7
E	#8
F	#9
H	#11

Address	Variable number
I	#4
J	#5
K	#6
M	#13
Q	#17
R	#18
S	#19

Address	Variable number
T	#20
U	#21
V	#22
W	#23
X	#24
Y	#25
Z	#26

- Addresses G, L, N, O, and P cannot be used in arguments.
- Addresses that need not be specified can be omitted. Local variables corresponding to an omitted address are set to null.
- Addresses do not need to be specified alphabetically. They conform to word address format.
I, J, and K need to be specified alphabetically, however.

Example

```
B_A_D_ ... J_K_ Correct
B_A_D_ ... J_I_ Incorrect
```

Argument specification II

Argument specification II uses A, B, and C once each and uses I, J, and K up to ten times. Argument specification II is used to pass values such as three-dimensional coordinates as arguments.

Address	Variable number	Address	Variable number	Address	Variable number
A	#1	K ₃	#12	J ₇	#23
B	#2	I ₄	#13	K ₇	#24
C	#3	J ₄	#14	I ₈	#25
I ₁	#4	K ₄	#15	J ₈	#26
J ₁	#5	I ₅	#16	K ₈	#27
K ₁	#6	J ₅	#17	I ₉	#28
I ₂	#7	K ₅	#18	J ₉	#29
J ₂	#8	I ₆	#19	K ₉	#30
K ₂	#9	J ₆	#20	I ₁₀	#31
I ₃	#10	K ₆	#21	J ₁₀	#32
J ₃	#11	I ₇	#22	K ₁₀	#33

- Subscripts of I, J, and K for indicating the order of argument specification are not written in the actual program.

Restrictions

- **Format**
- **Mixture of argument specifications I and II**

G65 must be specified before any argument.

The CNC internally identifies argument specification I and argument specification II. If a mixture of argument specification I and argument specification II is specified, the type of argument specification specified later takes precedence.

Example

```
G65 A1.0 B2.0 I-3.0 I4.0 D5.0 P1000;
```

<Variables>

```
#1:1.0
#2:2.0
#3:
#4:-3.0
#5:
#6:
#7: 5.0
```

When both the I4.0 and D5.0 arguments are commanded for variable #7 in this example, the latter, D5.0, is valid.

- **Position of the decimal point**
- **Call nesting**

The units used for argument data passed without a decimal point correspond to the least input increment of each address. The value of an argument passed without a decimal point may vary according to the system configuration of the machine. It is good practice to use decimal points in macro call arguments to maintain program compatibility.

Calls can be nested to a depth of four levels including simple calls (G65) and modal calls (G66). This does not include subprogram calls (M98).

● **Local variable levels**

- Local variables from level 0 to 4 are provided for nesting.
- The level of the main program is 0.
- Each time a macro is called (with G65 or G66), the local variable level is incremented by one. The values of the local variables at the previous level are saved in the CNC.
- When M99 is executed in a macro program, control returns to the calling program. At that time, the local variable level is decremented by one; the values of the local variables saved when the macro was called are restored.

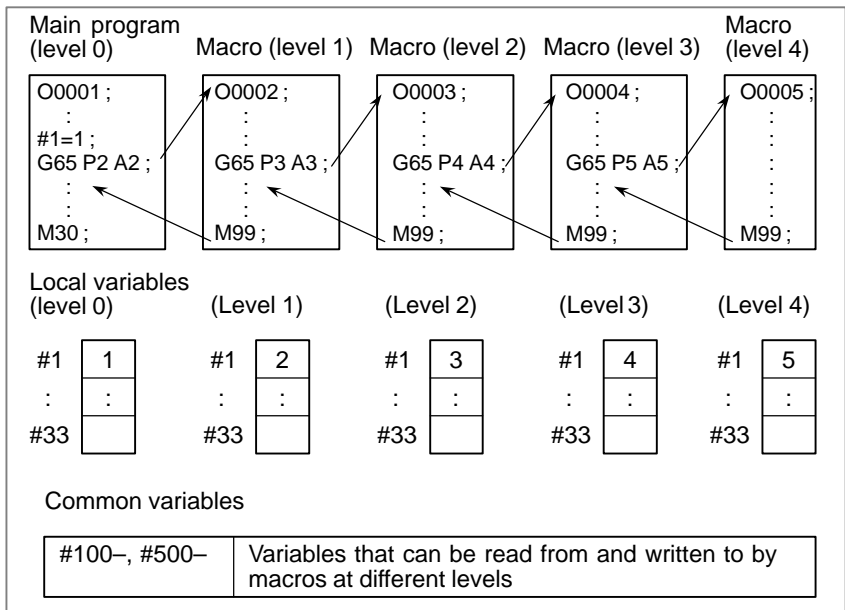

Sample program (Drill cycle)

Move the tool beforehand along the X- and Z-axes to the position where a drilling cycle starts. Specify Z or W for the depth of a hole, K for the depth of a cut, and F for the cutting feedrate to drill the hole.

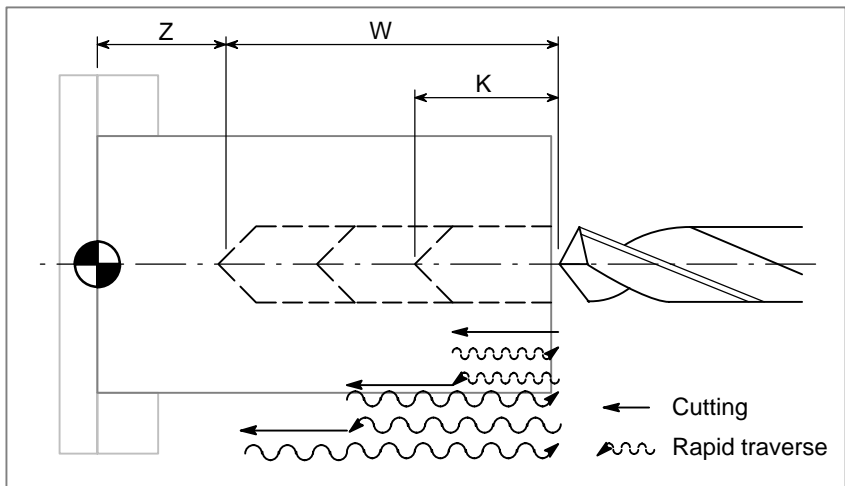

- **Calling format**

$G65 P9100 \left\{ \begin{array}{l} Zz \\ Ww \end{array} \right\} Kk Ff ;$
--

Z: Hole depth (absolute specification)

U: Hole depth (incremental specification)

K: Cutting amount per cycle

F: Cutting feedrate

- **Program calling a macro program**

```
O0002;
G50 X100.0 Z200.0 ;
G00 X0 Z102.0 S1000 M03 ;
G65 P9100 Z50.0 K20.0 F0.3 ;
G00 X100.0 Z200.0 M05 ;
M30 ;
```

- **Macro program (called program)**

```
O9100;
#1=0 ; ..... Clear the data for the depth of the current hole.
#2=0 ; ..... Clear the data for the depth of the preceding
hole.
IF [#23 NE #0] GOTO 1 ; ..... If incremental programming, specifies the
jump to N1.
IF [#26 EQ #0] GOTO 8 ; ..... If neither Z nor W is specified, an error occurs.
#23=#5002-#26 ; ..... Calculates the depth of a hole.
N1 #1=#1+#6 ; ..... Calculates the depth of the current hole.
IF [#1 LE #23] GOTO 2 ; ..... Determines whether the hole to be cut is
too deep?
#1=#23 ; ..... Clamps at the depth of the current hole.
N2 G00 W-#2 ; ..... Moves the tool to the depth of the preceding
hole at the cutting feedrate.
G01 W- [#1-#2] F#9 ; ..... Drills the hole.
G00 W#1 ; ..... Moves the tool to the drilling start point.
IF [#1 GE #23] GOTO 9 ; ..... Checks whether drilling is completed.
#2=#1 ; ..... Stores the depth of the current hole.
GOTO 1 ;
N9 M99 ;
N8 #3000=1 (NOT Z OR U COMMAND)
```

15.6.2 Modal Call (G66)

Once G66 is issued to specify a modal call a macro is called after a block specifying movement along axes is executed. This continues until G67 is issued to cancel a modal call.

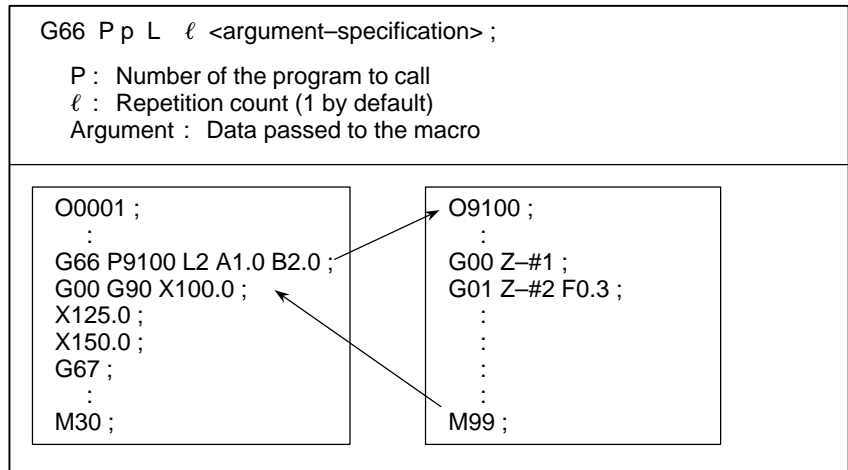

Explanations

• Call

- After G66, specify at address P a program number subject to a modal call.
- When a number of repetitions is required, a number from 1 to 9999 can be specified at address L.
- As with a simple call (G65), data passed to a macro program is specified in arguments.

• Cancellation

When a G67 code is specified, modal macro calls are no longer performed in subsequent blocks.

• Call nesting

Calls can be nested to a depth of four levels including simple calls (G65) and modal calls (G66). This does not include subprogram calls (M98).

• Modal call nesting

Modal calls can be nested by specifying another G66 code during a modal call.

Restrictions

- In a G66 block, no macros can be called.
- G66 needs to be specified before any arguments.
- No macros can be called in a block which contains a code such as a miscellaneous function that does not involve movement along an axis.
- Local variables (arguments) can only be set in G66 blocks. Note that local variables are not set each time a modal call is performed.

Sample program

This program makes a groove at a specified position.

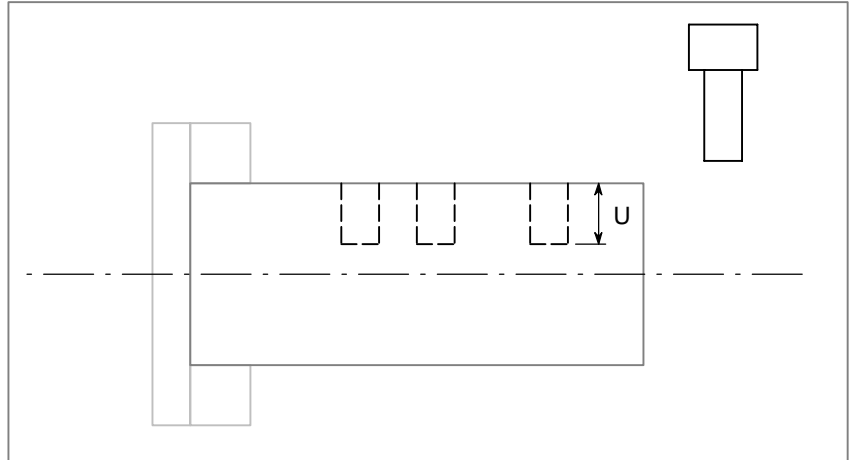

- **Calling format**

```
G66 P9110 Uu Ff ;
```

U: Groove depth (incremental specification)

F: Cutting feed of grooving

- **Program that calls a macro program**

```
O0003 ;
G50 X100.0 Z200.0 ;
S1000 M03 ;
G66 P9110 U5.0 F0.5 ;
G00 X60.0 Z80.0 ;
Z50.0 ;
Z30.0 ;
G67 ;
G00 X00.0 Z200.0 M05 ;
M30;
```

- **Macro program (program called)**

```
O9110 ;
G01 U-#21 F#9 ; ..... Cuts the workpiece.
G00 U#21 ; ..... Retracts the tool.
M99 ;
```

15.6.3 Macro Call Using G Code

By setting a G code number used to call a macro program in a parameter, the macro program can be called in the same way as for a simple call (G65).

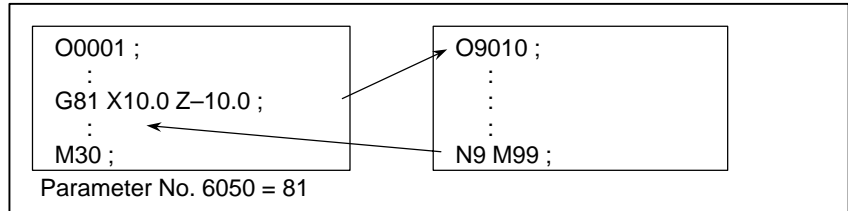

Explanations

By setting a G code number from 1 to 9999 used to call a custom macro program (9010 to 9019) in the corresponding parameter (Nos. 6050 to 6059), the macro program can be called in the same way as with G65. For example, when a parameter is set so that macro program O9010 can be called with G81, a user-specific cycle created using a custom macro can be called without modifying the machining program.

- **Correspondence between parameter numbers and program numbers**

Program number	Parameter number
O9010	6050
O9011	6051
O9012	6052
O9013	6053
O9014	6054
O9015	6055
O9016	6056
O9017	6057
O9018	6058
O9019	6059

- **Repetition**
- **Argument specification**

As with a simple call, a number of repetitions from 1 to 9999 can be specified at address L.

As with a simple call, two types of argument specification are available: Argument specification I and argument specification II. The type of argument specification is determined automatically according to the addresses used.

Restrictions

- **Nesting of calls using G codes**

In a program called with a G code, no macros can be called using a G code. A G code in such a program is treated as an ordinary G code. In a program called as a subprogram with an M or T code, no macros can be called using a G code. A G code in such a program is also treated as an ordinary G code.

15.6.4 Macro Call Using an M Code

By setting an M code number used to call a macro program in a parameter, the macro program can be called in the same way as with a simple call (G65).

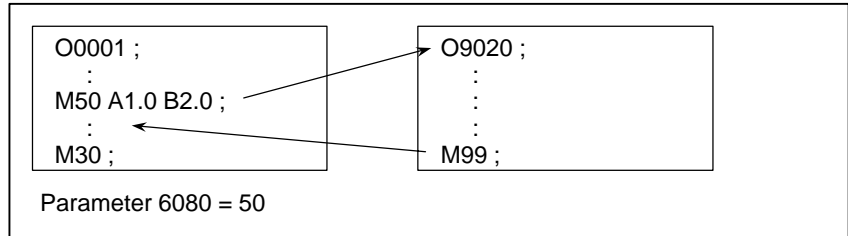

Explanations

By setting an M code number from 1 to 99999999 used to call a custom macro program (O9020 to O9029) in the corresponding parameter (Nos. 6080 to 6089), the macro program can be called in the same way as with G65.

- **Correspondence between parameter numbers and program numbers**

Program number	Parameter number
O9020	6080
O9021	6081
O9022	6082
O9023	6083
O9024	6084
O9025	6085
O9026	6086
O9027	6087
O9028	6088
O9029	6089

- **Repetition**
- **Argument specification**

As with a simple call, a number of repetitions from 1 to 9999 can be specified at address L.

As with a simple call, two types of argument specification are available: Argument specification I and argument specification II. The type of argument specification is determined automatically according to the addresses used.

Restrictions

- An M code used to call a macro program must be specified at the start of a block.
- In a macro called with a G code or in a program called as a subprogram with an M or T code, no macros can be called using an M code. An M code in such a macro or program is treated as an ordinary M code.

15.6.5 Subprogram Call Using an M Code

By setting an M code number used to call a subprogram (macro program) in a parameter, the macro program can be called in the same way as with a subprogram call (M98).

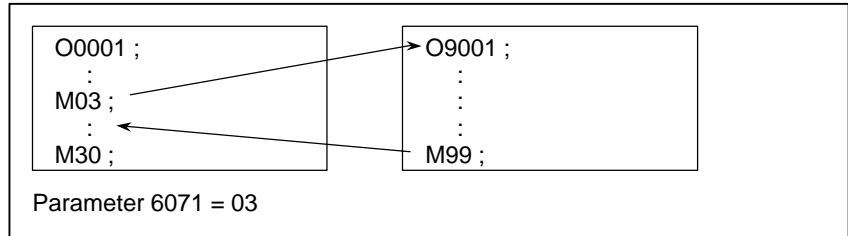

Explanations

By setting an M code number from 1 to 99999999 used to call a subprogram in a parameter (Nos. 6071 to 6076), the corresponding custom macro program (O9001 to O9006) can be called in the same way as with M98.

- **Correspondence between parameter numbers and program numbers**

Program number	Parameter number
O9001	6071
O9002	6072
O9003	6073
O9004	6074
O9005	6075
O9006	6076
O9007	6077
O9008	6078
O9009	6079

- **Repetition**
- **Argument specification**
- **M code**

As with a simple call, a number of repetitions from 1 to 9999 can be specified at address L.

Argument specification is not allowed.

An M code in a macro program that has been called is treated as an ordinary M code.

Limitations

In a macro called with a G code or in a program called with an M or T code, no subprograms can be called using an M code. An M code in such a macro or program is treated as an ordinary M code.

15.6.6 Subprogram Calls Using a T Code

By enabling subprograms (macro program) to be called with a T code in a parameter, a macro program can be called each time the T code is specified in the machining program.

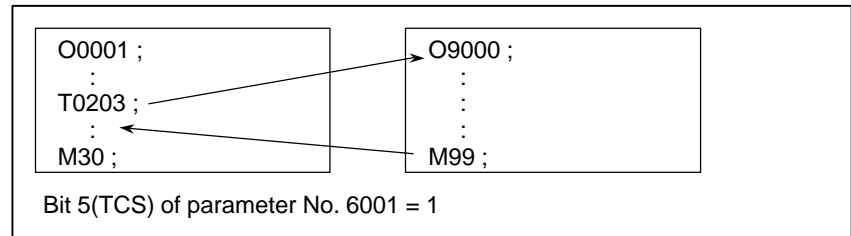

Explanations

- Call

By setting bit 5 (TCS) of parameter No. 6001 to 1, the macro program O9000 can be called when a T code is specified in the machining program. A T code specified in a machining program is assigned to common variable #149.

Limitations

In a macro called with a G code or in a program called with an M or T code, no subprograms can be called using a T code. A T code in such a macro or program is treated as an ordinary T code.

15.6.7 Sample Program

By using the subprogram call function that uses M codes, the cumulative usage time of each tool is measured.

Conditions

- The cumulative usage time of each of tool numbers 1 to 5 is measured. The time is not measured for tools whose number is 6 or more.
- The following variables are used to store the tool numbers and measured times:

#501	Cumulative usage time of tool number 1
#502	Cumulative usage time of tool number 2
#503	Cumulative usage time of tool number 3
#504	Cumulative usage time of tool number 4
#505	Cumulative usage time of tool number 5

- Usage time starts being counted when the M03 command is specified and stops when M05 is specified. System variable #3002 is used to measure the time during which the cycle start lamp is on. The time during which the machine is stopped by feed hold and single block stop operation is not counted, but the time used to change tools and pallets is included.

Operation check

- **Parameter setting**

Set 3 in parameter No. 6071, and set 05 in parameter No. 6072.

- **Variable value setting**

Set 0 in variables #501 to #505.

- **Program that calls a macro program**

```

O0001;
T0100 M06;
M03;
:
M05; ..... Changes #501.
T0200 M06;
M03;
:
M05; ..... Changes #502.
T0300 M06;
M03;
:
M05; ..... Changes #503.
T0400 M06;
M03;
:
M05; ..... Changes #504.
T0500 M06;
M03;
:
M05; ..... Changes #505.
M30;

```

**Macro program
(program called)**

O9001(M03); Macro to start counting
M01;
IF[FIX[#4120/100] EQ 0]GOTO 9; No tool specified
IF[FIX[#4120/100] GT 5]GOTO 9; Out-of-range tool number
#3002=0; Clears the timer.
N9 M03; Rotates the spindle in the forward direction.
M99;

O9002(M05); Macro to end counting
M01;
IF[FIX[#4120/100] EQ 0]GOTO 9; No tool specified
IF[FIX[#4120/100] GT 5]GOTO 9; Out-of-range tool number
#[500+FIX[#4120/100]]=#3002+#[500+FIX[#4120/100]];
..... Calculates cumulative time.

N9 M05; Stops the spindle.
M99;

15.7 PROCESSING MACRO STATEMENTS

For smooth machining, the CNC prereads the CNC statement to be performed next. This operation is referred to as buffering. In tool nose radius compensation mode (G41, G42), the NC prereads NC statements two or three blocks ahead to find intersections. Macro statements for arithmetic expressions and conditional branches are processed as soon as they are read into the buffer. Blocks containing M00, M01, M02, or M30, blocks containing M codes for which buffering is suppressed by setting parameter(Nos. 3411 to 3420), and blocks containing G31 are not preread.

Explanations

- **When the next block is not buffered (M codes that are not buffered, G31, etc.)**

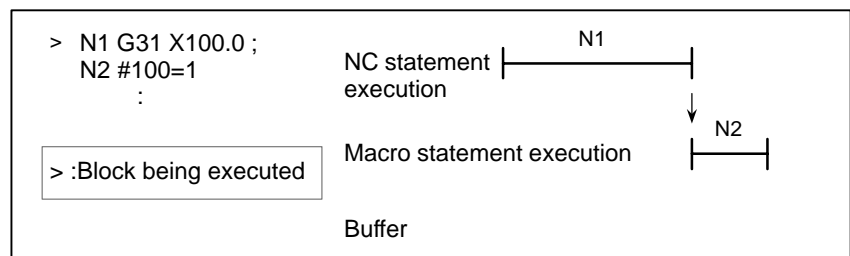

- **Buffering the next block in other than tool nose radius compensation mode (G41, G42) (normally prereading one block)**

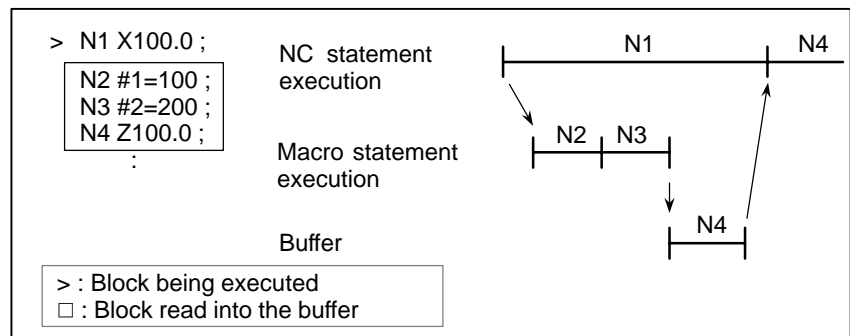

When N1 is being executed, the next NC statement (N4) is read into the buffer. The macro statements (N2, N3) between N1 and N4 are processed during execution of N1.

● **Buffering the next block in tool nose radius compensation mode (G41, G42)**

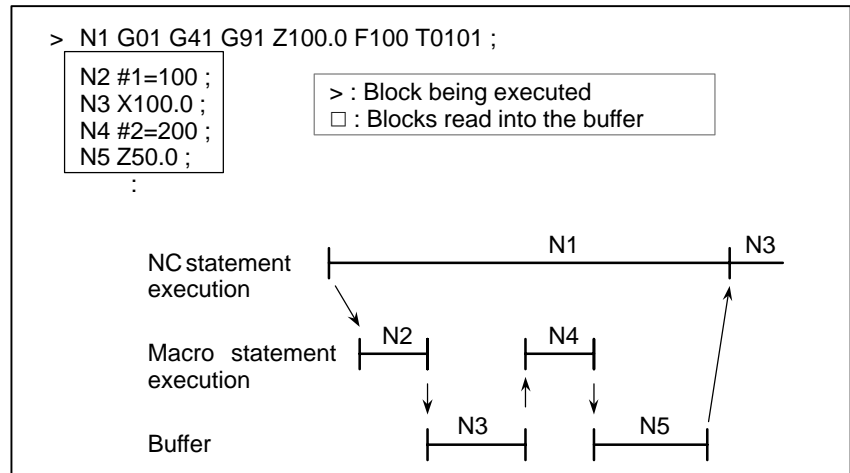

When N1 is being executed, the NC statements in the next two blocks (up to N5) are read into the buffer. The macro statements (N2, N4) between N1 and N5 are processed during execution of N1.

● **When the next block involves no movement in tool nose radius compensation C (G41, G42) mode**

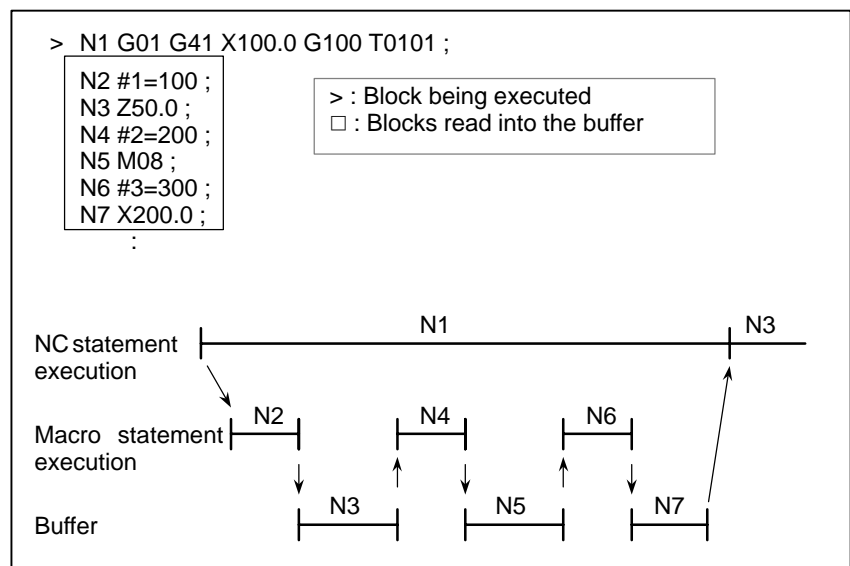

When the NC1 block is being executed, the NC statements in the next two blocks (up to N5) are read into the buffer. Since N5 is a block that involves no movement, an intersection cannot be calculated. In this case, the NC statements in the next three blocks (up to N7) are read. The macro statements (N2, N4, and N6) between N1 and N7 are processed during execution of N1.

15.8 REGISTERING CUSTOM MACRO PROGRAMS

Custom macro programs are similar to subprograms. They can be registered and edited in the same way as subprograms. The storage capacity is determined by the total length of tape used to store both custom macros and subprograms.

15.9 LIMITATIONS

- **MDI operation**

The macro call command can be specified in MDI mode too. During automatic operation, however, it is impossible to switch to the MDI mode for a macro program call.
- **Sequence number search**

A custom macro program cannot be searched for a sequence number.
- **Single block**

Even while a macro program is being executed, blocks can be stopped in the single block mode (except blocks containing macro call commands, arithmetic operation commands, and control commands).
A block containing a macro call command (G65, G66, or G67) does not stop even when the single block mode is on. Blocks containing arithmetic operation commands and control commands can be stopped in single block mode by setting SBM (bit 5 of parameter 6000) to 1.
Single block stop operation is used for testing custom macro programs. Note that when a single block stop occurs at a macro statement in tool nose radius compensation mode, the statement is assumed to be a block that does not involve movement, and proper compensation cannot be performed in some cases. (Strictly speaking, the block is regarded as specifying a movement with a travel distance 0.)
- **Optional block skip**

A / appearing in the middle of an <expression> (enclosed in brackets [] on the right-hand side of an arithmetic expression) is regarded as a division operator; it is not regarded as the specifier for an optional block skip code.
- **Operation in EDIT mode**

By setting NE8 (bit 0 of parameter 3202) and NE9 (bit 4 of parameter 3202) to 1, deletion and editing are disabled for custom macro programs and subprograms with program numbers 8000 to 8999 and 9000 to 9999. Registered custom macro programs and subprograms should be protected from being destroyed by accident. When the entire memory is cleared (by pressing the and keys at the same time to turn on the power), the contents of memory such as custom macro programs are deleted.
- **Reset**

With a reset operation, local variables and common variables #100 to #149 are cleared to null values. They can be prevented from being cleared by setting, CLV and CCV (bits 7 and 6 of parameter 6001). System variables #1000 to #1133 are not cleared.
A reset operation clears any called states of custom macro programs and subprograms, and any DO states, and returns control to the main program.
- **Display of the PROGRAM RESTART screen**

As with M98, the M and T codes used for subprogram calls are not displayed.
- **Feed hold**

When a feed hold is enabled during execution of a macro statement, the machine stops after execution of the macro statement. The machine also stops when a reset or alarm occurs.
- **Constant values that can be used in <expression>**

+0.0000001 to +999999999
-999999999 to -0.0000001
The number of significant digits is 8 (decimal). If this range is exceeded, P/S alarm No. 003 occurs.

15.10 EXTERNAL OUTPUT COMMANDS

In addition to the standard custom macro commands, the following macro commands are available. They are referred to as external output commands.

- **BPRNT**
- **DPRNT**
- **POPEN**
- **PCLOS**

These commands are provided to output variable values and characters through the reader/punch interface.

Explanations

Specify these commands in the following order:

Open command: **POPEN**

Before specifying a sequence of data output commands, specify this command to establish a connection to an external input/output device.

Data output command: **BPRNT or DPRNT**

Specify necessary data output.

Close command: **PCLOS**

When all data output commands have completed, specify PCLOS to release a connection to an external input/output device.

- **Open command POPEN**

POPEN

POPEN establishes a connection to an external input/output device. It must be specified before a sequence of data output commands. The CNC outputs a DC2 control code.

- **Data output command
BPRNT**

BPRNT [**a** #**b** [**c**] ...]

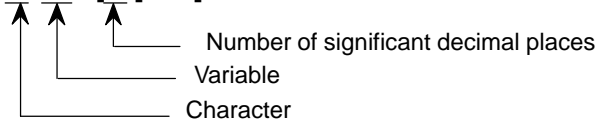

The BPRNT command outputs characters and variable values in binary.

(i) Specified characters are converted to corresponding ISO codes according to the setting data (ISO) that is output at that time.

Specifiable characters are as follows:

- **Letters (A to Z)**
- **Numbers**
- **Special characters (*, /, +, -, etc.)**

An asterisk (*) is output by a space code.

(ii) All variables are stored with a decimal point. Specify a variable followed by the number of significant decimal places enclosed in brackets. A variable value is treated as 2-word (32-bit) data, including the decimal digits. It is output as binary data starting from the highest byte.

(iii) When specified data has been output, an EOB code is output according to the ISO code settings.

(iv) Null variables are regarded as 0.

Example)

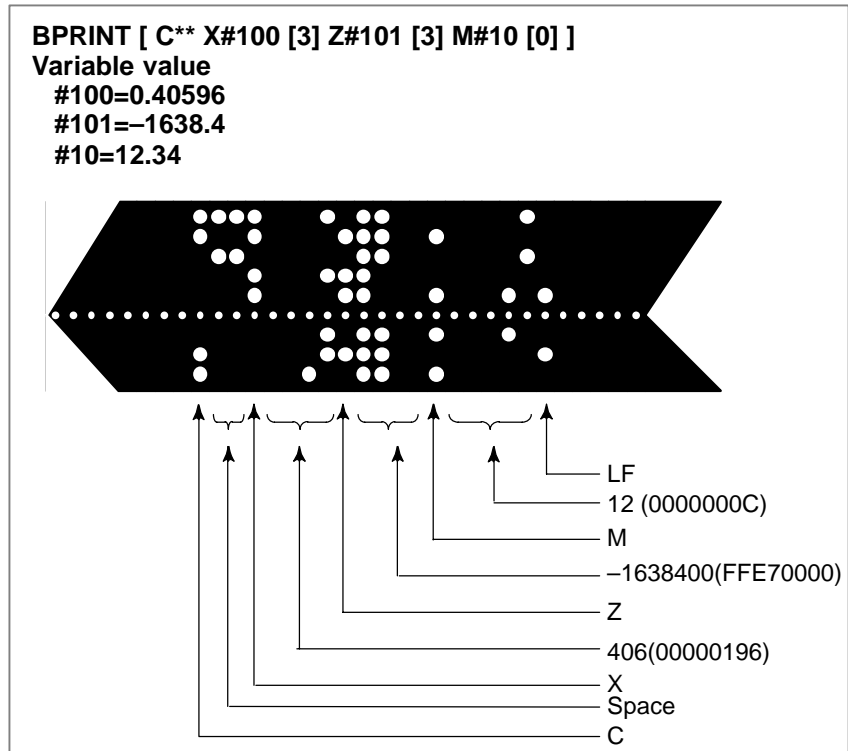

• **Data output command
DPRNT**

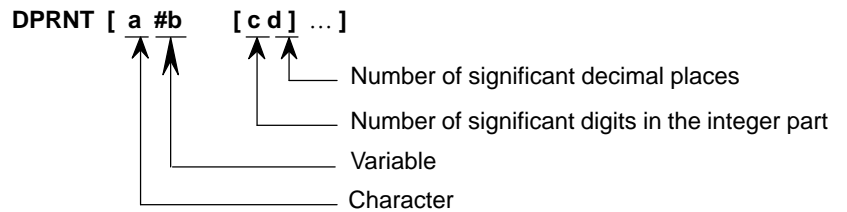

The DPRNT command outputs characters and each digit in the value of a variable according to the code set in the settings (ISO).

(i) For an explanation of the DPRNT command, see Items (i), (iii), and (iv) for the BPRINT command.

(ii) When outputting a variable, specify # followed by the variable number, then specify the number of digits in the integer part and the number of decimal places enclosed in brackets.

One code is output for each of the specified number of digits, starting with the highest digit. For each digit, a code is output according to the settings (ISO). The decimal point is also output using a code set in the settings (ISO).

Each variable must be a numeric value consisting of up to eight digits. When high-order digits are zeros, these zeros are not output if PRT (bit1 of parameter 6001) is 1. If PRT (bit 1 of parameter 6001) is 0, a space code is output each time a zero is encountered.

When the number of decimal places is not zero, digits in the decimal part are always output. If the number of decimal places is zero, no decimal point is output. When PRT (bit 1 of parameter 6001) is 0, a space code is output to indicate a positive number instead of +; if PRT(bit 1 of parameter 6001) is 1, no code is output.

Example)

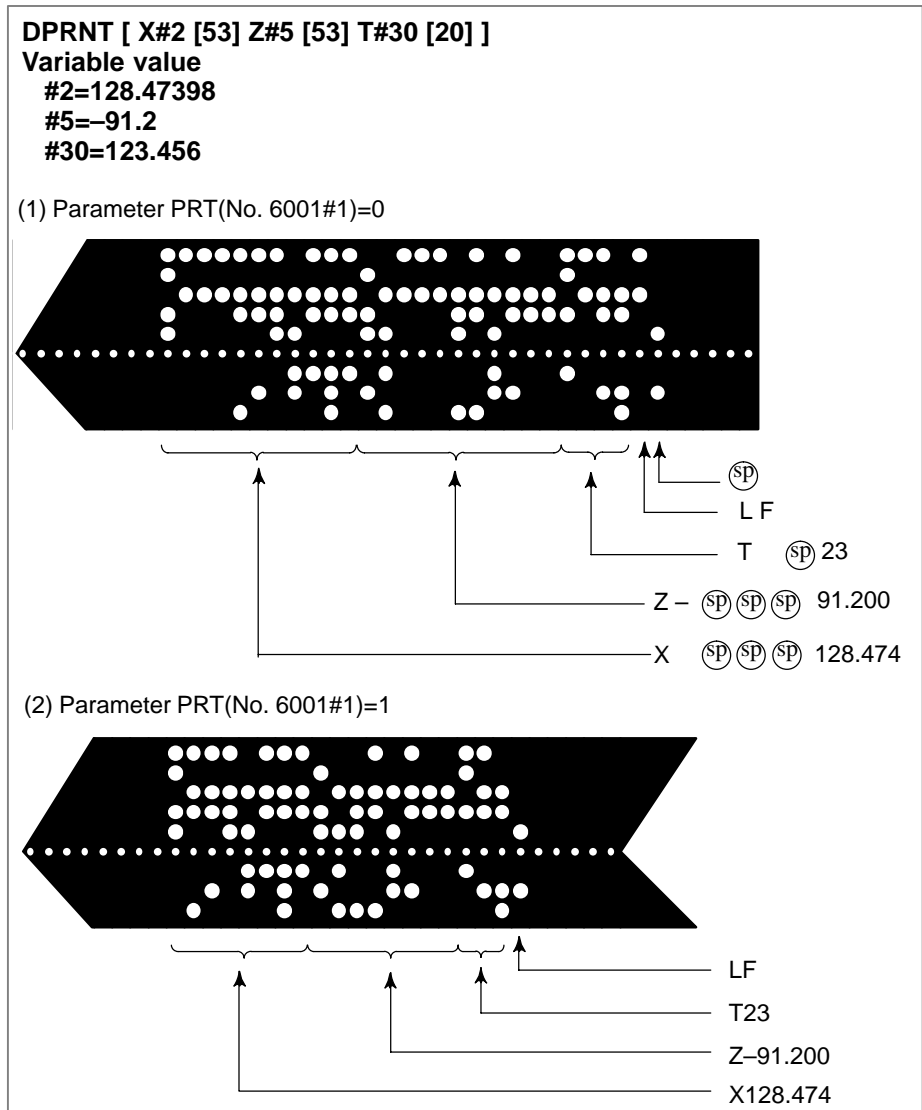

● **Close command PCLOS**

PCLOS ;

The PCLOS command releases a connection to an external input/output device. Specify this command when all data output commands have terminated. DC4 control code is output from the CNC.

● **Required setting**

Specify the channel use for parameter 020. According to the specification of this parameter, set data items (such as the baud rate) for the reader/punch interface.

I/O channel 0 : Parameters 101, 102 and 103

I/O channel 1 : Parameters 111, 112 and 113

I/O channel 2 : Parameters 121, 122 and 123

Never specify output to the Fanuc Cassette or floppy disks.)

When specifying a DPRNT command to output data, specify whether leading zeros are output as spaces (by setting PRT (bit 1 of parameter 6001) to 1 or 0). To indicate the end of a line of data in ISO code, specify whether to use only an LF (NCR, of bit 3 of parameter 0103 is 0) or an LF and CR (NCR is 1).

NOTE

- 1 It is not necessary to always specify the open command (POPEN), data output command (BPRNT, DPRNT), and close command (PCLOS) together. Once an open command is specified at the beginning of a program, it does not need to be specified again except after a close command was specified.
- 2 Be sure to specify open commands and close commands in pairs. Specify the close command at the end of the program. However, do not specify a close command if no open command has been specified.
- 3 When a reset operation is performed while commands are being output by a data output command, output is stopped and subsequent data is erased. Therefore, when a reset operation is performed by a code such as M30 at the end of a program that performs data output, specify a close command at the end of the program so that processing such as M30 is not performed until all data is output.
- 4 Abbreviated macro words enclosed in brackets [] remains unchanged. However, note that when the characters in brackets are divided and input several times, the second and subsequent abbreviations are converted and input.
- 5 O can be specified in brackets []. Note that when the characters in brackets [] are divided and input several times, O is omitted in the second and subsequent inputs.

15.11 INTERRUPTION TYPE CUSTOM MACRO

When a program is being executed, another program can be called by inputting an interrupt signal (UINT) from the machine. This function is referred to as an interruption type custom macro function. Program an interrupt command in the following format:

Format

M96 P○○○○ ;	Enables custom macro interrupt
M97 ;	Disables custom macro interrupt

Explanations

Use of the interruption type custom macro function allows the user to call a program during execution of an arbitrary block of another program. This allows programs to be operated to match situations which vary from time to time.

- (1) When a tool abnormality is detected, processing to handle the abnormality is started by an external signal.
- (2) A sequence of machining operations is interrupted by another machining operation without the cancellation of the current operation.
- (3) At regular intervals, information on current machining is read.
Listed above are examples like adaptive control applications of the interruption type custom macro function.

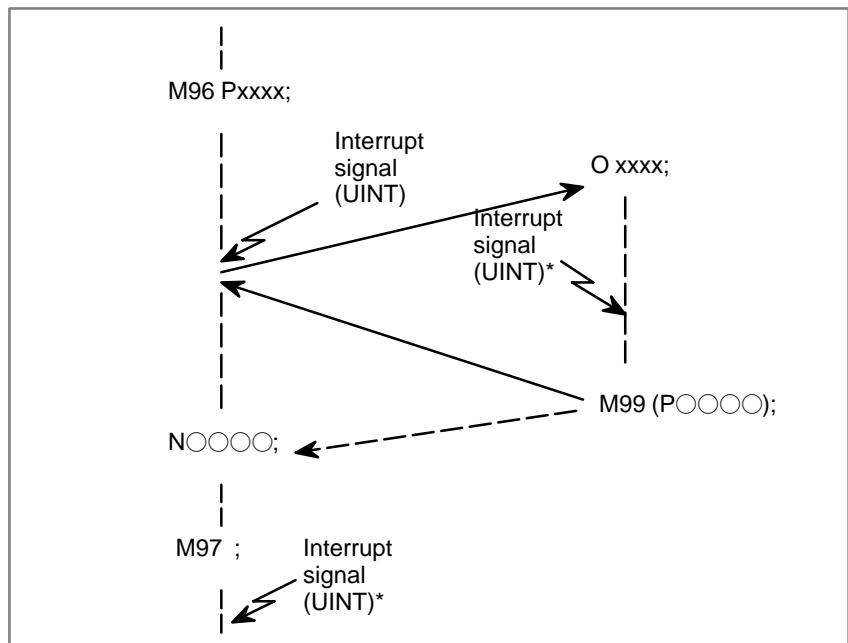

Fig. 15.11 Interruption type custom macro function

When M96Pxxxx is specified in a program, subsequent program operation can be interrupted by an interrupt signal (UINT) input to execute the program specified by Pxxxx.

CAUTION

When the interrupt signal (UINT, marked by * in Fig. 15.11) is input after M97 is specified, it is ignored. And the interrupt signal must not be input during execution of the interrupt program.

15.11.1 Specification Method

Explanations

- **Interrupt conditions**

A custom macro interrupt is available only during program execution. It is enabled under the following conditions

- **When memory operation or MDI operation is selected**
- **When STL (start lamp) is on**
- **When a custom macro interrupt is not currently being processed**

- **Specification**

Generally, the custom macro interrupt function is used by specifying M96 to enable the interrupt signal (UINT) and M97 to disable the signal. Once M96 is specified, a custom macro interrupt can be initiated by the input of the interrupt signal (UINT) until M97 is specified or the NC is reset. After M97 is specified or the NC is reset, no custom macro interrupts are initiated even when the interrupt signal (UINT) is input. The interrupt signal (UINT) is ignored until another M96 command is specified.

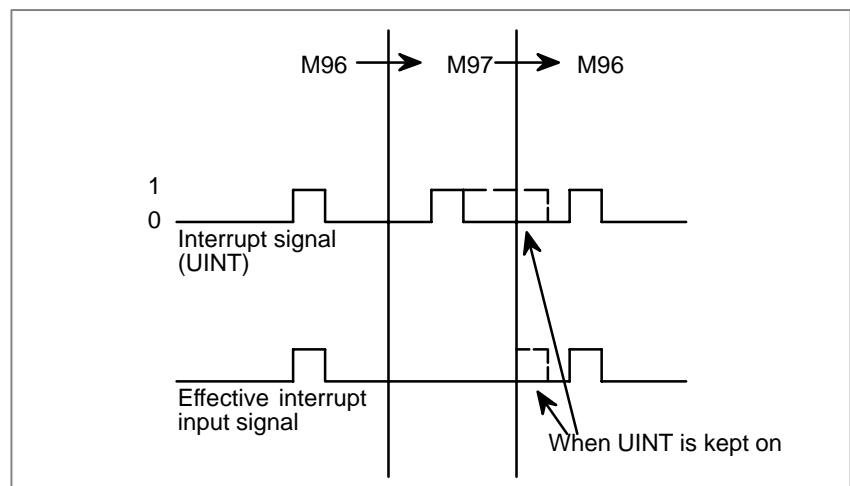

The interrupt signal (UINT) becomes valid after M96 is specified. Even when the signal is input in M97 mode, it is ignored. When the signal input in M97 mode is kept on until M96 is specified, a custom macro interrupt is initiated as soon as M96 is specified (only when the status-triggered scheme is employed); when the edge-triggered scheme is employed, the custom macro interrupt is not initiated even when M96 is specified.

NOTE

For the status-triggered and edge-triggered schemes, see Item "Custom macro interrupt signal (UINT)" of Subsec. 16.11.2.

15.11.2**Details of Functions****Explanations**

- **subprogram-type interrupt and macro-type interrupt**

There are two types of custom macro interrupts: Subprogram-type interrupts and macro-type interrupts. The interrupt type used is selected by MSB (bit 5 of parameter 6003).

- (a) **Subprogram-type interrupt**

An interrupt program is called as a subprogram. This means that the levels of local variables remain unchanged before and after the interrupt. This interrupt is not included in the nesting level of subprogram calls.

- (b) **Macro-type interrupt**

An interrupt program is called as a custom macro. This means that the levels of local variables change before and after the interrupt. The interrupt is not included in the nesting level of custom macro calls. When a subprogram call or a custom macro call is performed within the interrupt program, this call is included in the nesting level of subprogram calls or custom macro calls. Arguments cannot be passed from the current program even when the custom macro interrupt is a macro-type interrupt.

- **M codes for custom macro interrupt control**

In general, custom macro interrupts are controlled by M96 and M97. However, these M codes, may already being used for other purposes (such as an M function or macro M code call) by some machine tool builders. For this reason, MPR (bit 4 of parameter 6003) is provided to set M codes for custom macro interrupt control.

When specifying this parameter to use the custom macro interrupt control M codes set by parameters, set parameters 6033 and 6034 as follows:

Set the M code to enable custom macro interrupts in parameter 6033, and set the M code to disable custom macro interrupts in parameter 6034.

When specifying that parameter-set M codes are not used, M96 and M97 are used as the custom macro control M codes regardless of the settings of parameters 6033 and 6034.

The M codes used for custom macro interrupt control are processed internally (they are not output to external units). However, in terms of program compatibility, it is undesirable to use M codes other than M96 and M97 to control custom macro interrupts.

- **Custom macro interrupts and NC statements**

When performing a custom macro interrupt, the user may want to interrupt the NC statement being executed, or the user may not want to perform the interrupt until the execution of the current block is completed. MIN (bit 2 of parameter 6003) is used to select whether to perform interrupts even in the middle of a block or to wait until the end of the block.

• **Type I
(when an interrupt is performed even in the middle of the block)**

- (i) When the interrupt signal (UINT) is input, any movement or dwell being performed is stopped immediately and the interrupt program is executed.
- (ii) If there are NC statements in the interrupt program, the command in the interrupted block is lost and the NC statement in the interrupt program is executed. When control is returned to the interrupted program, the program is restarted from the next block after the interrupted block.
- (iii) If there are no NC statements in the interrupt program, control is returned to the interrupted program by M99, then the program is restarted from the command in the interrupted block.

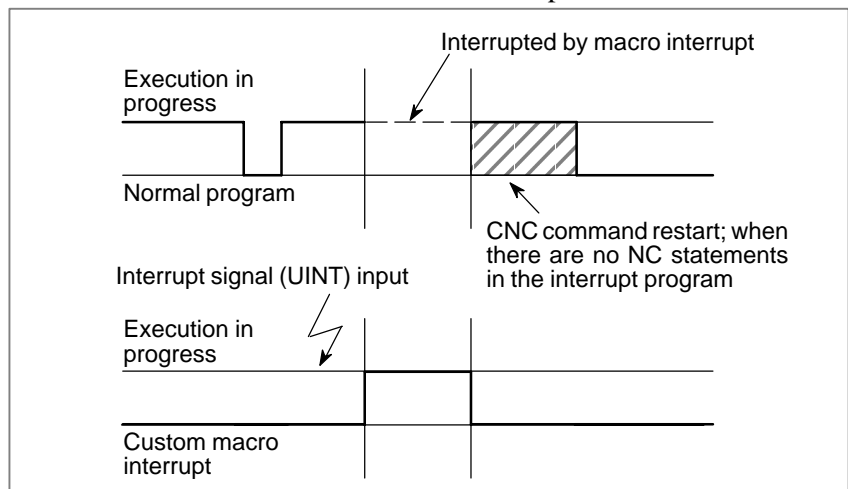

• **Type II
(when an interrupt is performed at the end of the block)**

- (i) If the block being executed is not a block that consists of several cycle operations such as a drilling canned cycle and automatic reference position return (G28), an interrupt is performed as follows: When an interrupt signal (UINT) is input, macro statements in the interrupt program are executed immediately unless an NC statement is encountered in the interrupt program. NC statements are not executed until the current block is completed.
- (ii) If the block being executed consists of several cycle operations, an interrupt is performed as follows: When the last movement in the cycle operations is started, macro statements in the interrupt program are executed unless an NC statement is encountered. NC statements are executed after all cycle operations are completed.

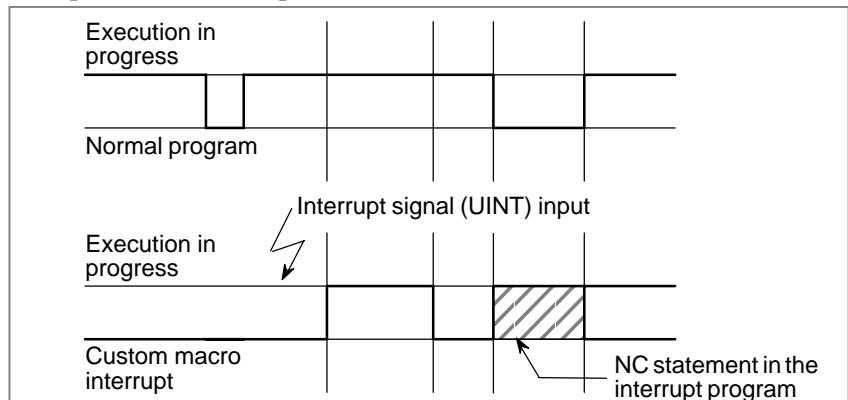

- **Conditions for enabling and disabling the custom macro interrupt signal**

The interrupt signal becomes valid after execution starts of a block that contains M96 for enabling custom macro interrupts. The signal becomes invalid when execution starts of a block that contains M97.

While an interrupt program is being executed, the interrupt signal becomes invalid. The signal become valid when the execution of the block that immediately follows the interrupted block in the main program is started after control returns from the interrupt program. In type I, if the interrupt program consists of only macro statements, the interrupt signal becomes valid when execution of the interrupted block is started after control returns from the interrupt program.

- **Custom macro interrupt during execution of a block that involves cycle operation**

- **For type I**

Even when cycle operation is in progress, movement is interrupted, and the interrupt program is executed. If the interrupt program contains no NC statements, the cycle operation is restarted after control is returned to the interrupted program. If there are NC statements, the remaining operations in the interrupted cycle are discarded, and the next block is executed.

- **For type II**

When the last movement of the cycle operation is started, macro statements in the interrupt program are executed unless an NC statement is encountered. NC statements are executed after cycle operation is completed.

● **Custom macro interrupt signal (UINT)**

There are two schemes for custom macro interrupt signal (UINT) input: The status-triggered scheme and edge-triggered scheme. When the status-triggered scheme is used, the signal is valid when it is on. When the edge-triggered scheme is used, the signal becomes valid on the rising edge when it switches from off to on status.

One of the two schemes is selected with TSE (bit 3 of parameter 6003). When the status-triggered scheme is selected by this parameter, a custom macro interrupt is generated if the interrupt signal (UINT) is on at the time the signal becomes valid. By keeping the interrupt signal (UINT) on, the interrupt program can be executed repeatedly.

When the edge-triggered scheme is selected, the interrupt signal (UINT) becomes valid only on its rising edge. Therefore, the interrupt program is executed only momentarily (in cases when the program consists of only macro statements). When the status-triggered scheme is inappropriate, or when a custom macro interrupt is to be performed just once for the entire program (in this case, the interrupt signal may be kept on), the edge-triggered scheme is useful.

Except for the specific applications mentioned above, use of either scheme results in the same effects. The time from signal input until a custom macro interrupt is executed does not vary between the two schemes.

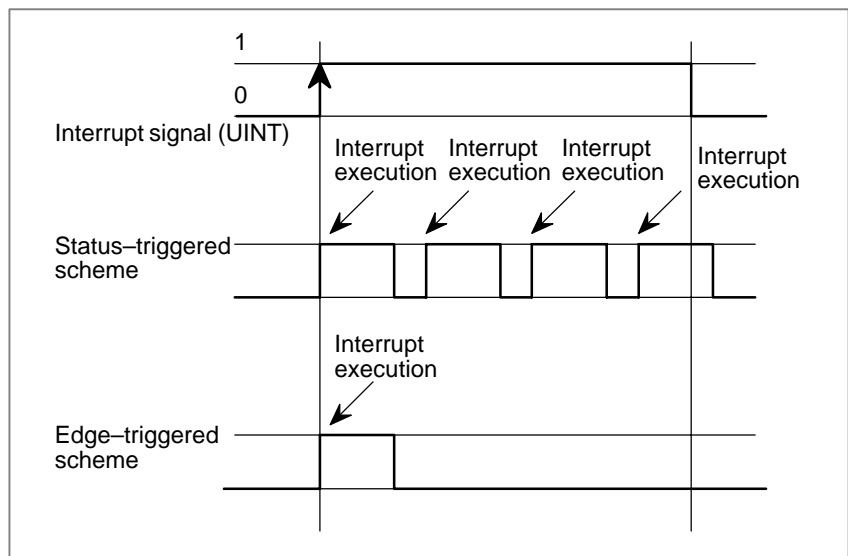

In the above example, an interrupt is executed four times when the status triggered scheme is used; when the edge-triggered scheme is used, the interrupt is executed just once.

- **Return from a custom macro interrupt**

To return control from a custom macro interrupt to the interrupted program, specify M99. A sequence number in the interrupted program can also be specified using address P. If this is specified, the program is searched from the beginning for the specified sequence number. Control is returned to the first sequence number found.

When a custom macro interrupt program is being executed, no interrupts are generated. To enable another interrupt, execute M99. When M99 is specified alone, it is executed before the preceding commands terminate. Therefore, a custom macro interrupt is enabled for the last command of the interrupt program. If this is inconvenient, custom macro interrupts should be controlled by specifying M96 and M97 in the program.

When a custom macro interrupt is being executed, no other custom macro interrupts are generated; when an interrupt is generated, additional interrupts are inhibited automatically. Executing M99 makes it possible for another custom macro interrupt to occur. M99 specified alone in a block is executed before the previous block terminates. In the following example, an interrupt is enabled for the Gxx block of O1234. When the signal is input, O1234 is executed again. O5678 is controlled by M96 and M97. In this case, an interrupt is not enabled for O5678 (enabled after control is returned to O1000).

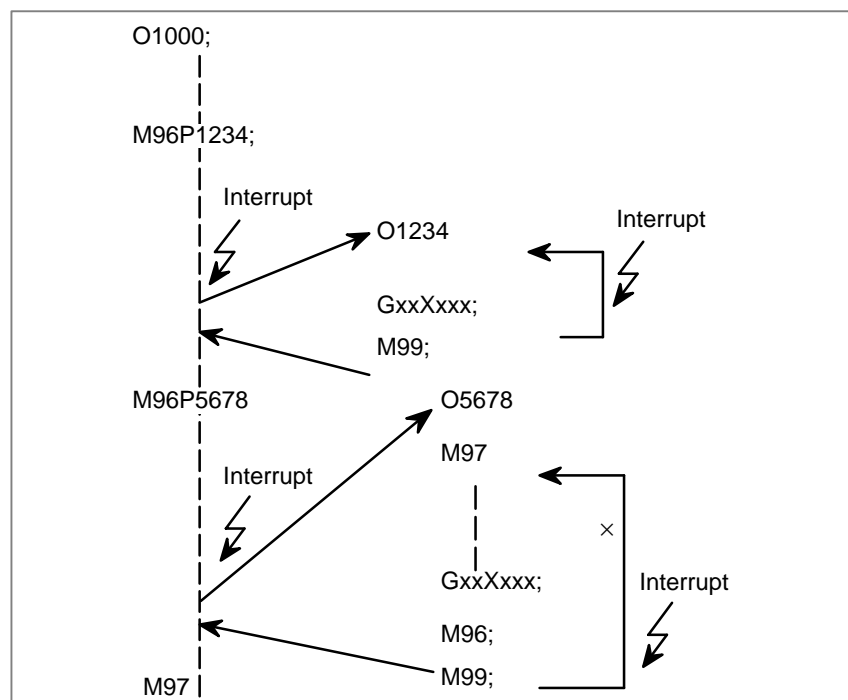

NOTE

When an M99 block consists only of address O, N, P, L, or M, this block is regarded as belonging to the previous block in the program. Therefore, a single-block stop does not occur for this block. In terms of programming, the following (1) and (2) are basically the same. (The difference is whether G○○ is executed before M99 is recognized.)

- (1) G○○ X○○○;
M99;
- (2) G○○ X○○○ M99;

• **Custom macro interrupt and modal information**

A custom macro interrupt is different from a normal program call. It is initiated by an interrupt signal (UINT) during program execution. In general, any modifications of modal information made by the interrupt program should not affect the interrupted program.

For this reason, even when modal information is modified by the interrupt program, the modal information before the interrupt is restored when control is returned to the interrupted program by M99.

When control is returned from the interrupt program to the interrupted program by M99 Pxxxx, modal information can again be controlled by the program. In this case, the new continuous information modified by the interrupt program is passed to the interrupted program. Restoration of the old modal information present before the interrupt is not desirable. This is because after control is returned, some programs may operate differently depending on the modal information present before the interrupt. In this case, the following measures are applicable:

- (1) The interrupt program provides modal information to be used after control is returned to the interrupted program.
- (2) After control is returned to the interrupted program, modal information is specified again as necessary.

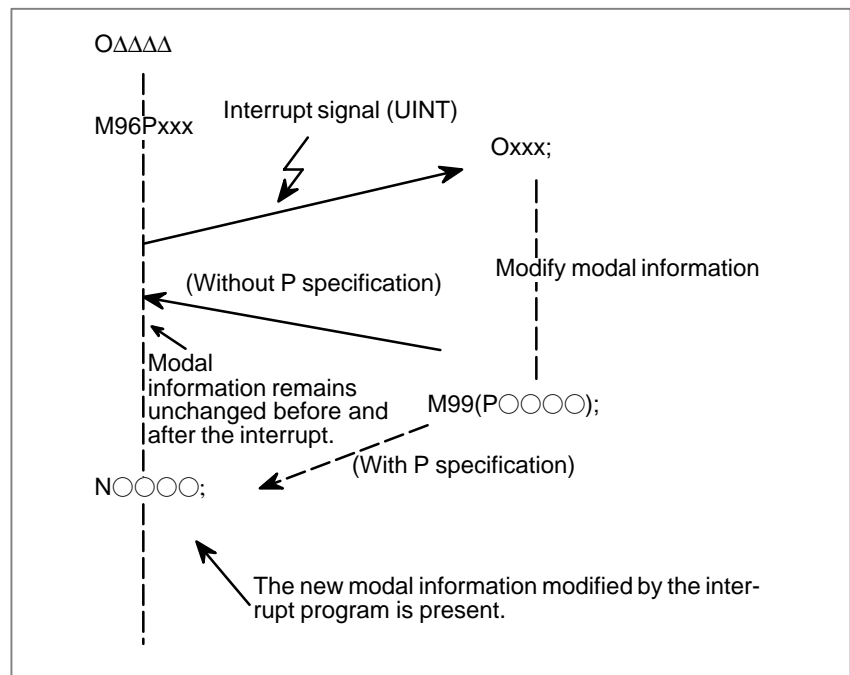

• **Modal information when control is returned by M99**

The modal information present before the interrupt becomes valid. The new modal information modified by the interrupt program is made invalid.

• **Modal information when control is returned by M99 P○○○○**

The new modal information modified by the interrupt program remains valid even after control is returned. The old modal information which was valid in the interrupted block can be read using custom macro system variables #4001 to #4120.

Note that when modal information is modified by the interrupt program, system variables #4001 to #4120 are not changed.

- **System variables (position information values) for the interrupt program**

- The coordinates of point A can be read using system variables #5001 and up until the first NC statement is encountered.
- The coordinates of point A' can be read after an NC statement with no move specifications appears.
- The machine coordinates and workpiece coordinates of point B' can be read using system variables #5021 and up and #5041 and up.

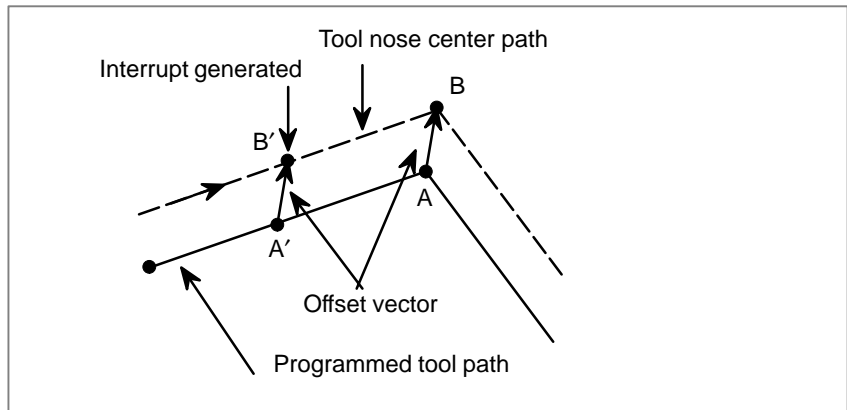

- **Custom macro interrupt and custom macro modal call**

When the interrupt signal (UINT) is input and an interrupt program is called, the custom macro modal call is canceled (G67). However, when G66 is specified in the interrupt program, the custom macro modal call becomes valid. When control is returned from the interrupt program by M99, the modal call is restored to the state it was in before the interrupt was generated. When control is returned by M99Pxxxx;, the modal call in the interrupt program remains valid.

- **Custom macro interrupt and program restart**

When the interrupt signal (UINT) is input while a return operation is being performed in the dry run mode after the search operation for program restart, the interrupt program is called after restart operation terminates for all axes. This means that interrupt type II is used regardless of the parameter setting.

- **DNC operation and Interruption type custom macro**

“Interruption type custom macro” cannot be done during DNC operation or executing a program with an external input-output device.

16 PROGRAMMABLE PARAMETER ENTRY (G10)



General

The values of parameters can be entered in a program. This function is used for setting pitch error compensation data when attachments are changed or the maximum cutting feedrate or cutting time constants are changed to meet changing machining conditions.

Format

Format	
G10L50;	Parameter entry mode setting
N_R_;	For parameters other than the axis type
N_P_R_;	For axis type parameters
⋮	
G11;	Parameter entry mode cancel
Meaning of command	
N_:	Parameter No. (4digits) or compensation position No.(0 to 1023) for pitch errors compensation +10,000 (5digit)
R_:	Parameter setting value (Leading zeros can be omitted.)
P_:	Axis No. 1 to 8 (Used for entering axis type parameters)

Explanations

- **Parameter setting value (R_)**
- **Axis No. (P_)**

Do not use a decimal point in a value set in a parameter (R_).
 a decimal point cannot be used in a custom macro variable for R_ either.

Specify an axis number (P_) from 1 to 8 (up to eight axes) for an axis type parameter. The control axes are numbered in the order in which they are displayed on the CNC display.
 For example, specify P2 for the control axis which is displayed second.

WARNING

- 1 Do not fail to perform reference point return manually after changing the pitch error compensation data or backlash compensation data. Without this, the machine position can deviate from the correct position.
- 2 The canned-cycle mode must be cancelled before entering of parameters. When not cancelled, the drilling motion will be activated.

NOTE

Other NC statements cannot be specified while in parameter input mode.

Examples

1. Set bit 2 (SPB) of bit type parameter No. 3404

G10L50 ;	Parameter entry mode
N3404 R 00000100 ;	SBP setting
G11 ;	cancel parameter entry mode

2. Change the values for the Z-axis (2nd axis) and C-axis (4th axis) in axis type parameter No. 1322 (the coordinates of stored stroke limit 2 in the positive direction for each axis).

G10L50 ;	Parameter entry mode
N1322P2R4500 ;	Modify Z axis
N1322P4R12000 ;	Modify C axis
G11 ;	cancel parameter entry mode

17

MEMORY OPERATION BY Series 15 TAPE FORMAT

Programs in the Series 15 tape format can be registered in memory for memory operation by setting bit 1 of parameter No. 0001. Registration to memory and memory operation are possible for the functions which use the same tape format as that for the Series 15 as well as for the following functions which use a different tape format:

- **Equal-lead threading**
- **Subprogram calling**
- **Canned cycle**
- **Multiple repetitive canned cycle**
- **Canned drilling cycle**

NOTE

Registration to memory and memory operation are possible only for the functions available in this CNC.

17.1 ADDRESSES AND SPECIFIABLE VALUE RANGE FOR Series 15 TAPE FORMAT

Some addresses which cannot be used for the this CNC can be used in the Series 15 tape format. The specifiable value range for the Series 15 tape format is basically the same as that for the this CNC. Sections II-17.2 to II-17.5 describe the addresses with a different specifiable value range. If a value out of the specifiable value range is specified, an alarm is issued.

17.2 EQUAL-LEAD THREADING

Format

```

G32IP_F_Q_;
      or
G32IP_E_Q_;

IP:Combination of axis addresses
F :Lead along the longitudinal axis
E :Lead along the longitudinal axis
Q :Sight of the threading start angle
    
```

Explanations

- **Address**

Although the Series 15 allows the operator to specify the number of threads per inch with address E, the Series 15 tape format does not. Addresses E and F are used in the same way for specifying the lead along the longitudinal axis. The thread lead specified with address E is therefore also assumed as a continuous-state value for address F.

- **Specifiable value range for the thread lead**

Address for thread lead		mm input	inch input
E		0.0001 to 500.0000 mm	0.000001 to 9.999999 inch
F	Command with a decimal point	0.0001 to 500.0000 mm	0.000001 to 9.999999 inch
	Command without a decimal point	0.01 to 500.00 mm	0.0001 to 9.9999 inch

- **Specifiable value range for the feedrate**

Address for feedrate		mm input	inch input
F	Feed per minute	Increment system (IS-B)	1 to 240000 mm/min 0.01 to 9600.00 inch/min
		Increment system (IS-C)	1 to 100000 mm/min 0.01 to 4800.00 inch/min
	Feed per rotation		0.01 to 500.00 mm/rev 0.0001 to 9.9999 inch/rev

WARNING
Specify the feedrate one more time when switching between feed per minute and feed per rotation.

17.3 SUBPROGRAM CALLING

Format

M98P○○○○**L**○○○○;

P:Subprogram number
L:Repetition count

Explanation

- **Address**

Address L cannot be used in this CNC tape format but can be used in the Series 15 tape format.
- **Subprogram number**

The specifiable value range is the same as that for this CNC (1 to 9999). If a value of more than four digits is specified, the last four digits are assumed as the subprogram number.
- **Repetition count**

The repetition count L can be specified in the range from 1 to 9999. If no repetition count is specified, 1 is assumed.

17.4 CANNED CYCLE

Format

<p>Outer / inner surface turning cycle (straight cutting cycle) G90X_Z_F_;</p> <p>Outer / inner surface turning cycle (taper cutting cycle) G90X_Z_I_F_; I:Length of the taper section along the X-axis (radius)</p> <p>Threading cycle (straight threading cycle) G92X_Z_F_Q_; F:Thread lead Q:Shift of the threading start angle</p> <p>Threading cycle (taper threading cycle) G92X_Z_I_F_; I:Length of the taper section along the X-axis (radius)</p> <p>End surface turning cycle (front taper cutting cycle) G94X_Z_F_;</p> <p>End surface turning cycle (front taper cutting cycle) G94X_Z_K_F_; K:Length of the taper section along the Z-axis</p>

- **Address**

Addresses I and K cannot be used for a canned cycle in this CNC tape format but can be used in the Series 15 tape format.

- **Specifiable value range for the feedrate**

Same as that for equal-lead threading in section II-17.2. See section II-17.2.

17.5 MULTIPLE REPETITIVE CANNED TURNING CYCLE

Format

Outer / inner surface turning cycle

G71P_Q_U_W_I_K_D_F_S_T_;

- I : Length and direction of cutting allowance for finishing the rough machining cycle along the X-axis (ignored if specified)
- K : Length and direction of cutting allowance for finishing the rough machining cycle along the Z-axis (ignored if specified)
- D : Depth of cut

End surface rough machining cycle

G72P_Q_U_W_I_K_D_F_S_T_;

- I : Length and direction of cutting allowance for finishing the rough machining cycle along the X-axis (ignored if specified)
- K : Length and direction of cutting allowance for finishing the rough machining cycle along the Z-axis (ignored if specified)
- D : Depth of cut

Closed-loop turning cycle

G73P_Q_U_W_I_K_D_F_S_T_;

- I : Length and direction of clearance along the X-axis (radius)
- K : Length and direction of clearance along the Z-axis
- D : Number of divisions

End surface cutting-off cycle

G74X_Z_I_K_F_D_;

or

G74U_W_I_K_F_D_;

- I : Distance to be traveled along the X-axis
- K : Depth of cut along the Z-axis
- D : Clearance of the tool at the end of the cutting path

Outer / inner surface cutting-off cycle

G75X_Z_I_K_F_D_;

or

G75U_W_I_K_F_D_;

- I : Distance to be traveled along the X-axis
- K : Depth of cut along the Z-axis
- D : Clearance of the tool at the end of the cutting path

Multiple repetitive threading cycle

G76X_Z_I_K_D_F_A_P_Q_;

- I : Difference of radiuses at threads
- K : Height of thread crest (radius)
- D : Depth of the first cut (radius)
- A : Angle of the tool tip (angle of ridges)
- P : Method of cutting

- **Addresses and specifiable value range**

If the following addresses are specified in the Series 15 tape format, they are ignored.

- I and K for the outer/inner surface rough machining cycle (G71)
- I and K for the end surface rough machining cycle (G72)

For the multiple repetitive threading cycle (G76), specify P1 (constant depth of cutting with a single edge) or P2 (constant depth of zigzag thread cutting with both edges) as the cutting method (P). A value of between 0 and 120 degrees can be specified for tool tip angle A. If other values are specified, P/S alarm 062 is issued.

Address D (cutting depth and retraction distance) can be specified with a value between -99999999 and 99999999, in the minimum input increment, even when calculator-like decimal point input is specified (when bit 0 (DPI) of parameter No. 3401 is set to 1). When address D contains a decimal point, P/S alarm No. 007 is issued.

The specifiable value range for the feedrate is the same as that for equal-lead threading. See section II-17.2.

17.6 CANNED DRILLING CYCLE FORMATS

Format

Drilling cycle

G81X_C_Z_F_L_ ; or G82X_C_Z_R_F_L_ ;

R : Distance from the initial level to the R position

P : Dwell time at the bottom of the hole

F : Cutting feedrate

L : Number of repetitions

Peck drilling cycle

G81X_C_Z_R_Q_P_F_L_ ;

R : Distance from the initial level to the R position

Q : Depth of cut in each cycle

P : Dwell time at the bottom of the hole

F : Cutting feedrate

L : Number of repetitions

High-speed peck drilling cycle

G83.1X_C_Z_R_Q_P_F_L_ ;

R : Distance from the initial level to the R position

Q : Depth of cut in each cycle

P : Dwell time at the bottom of the hole

F : Cutting feedrate

L : Number of repetitions

Tapping

G84X_C_Z_R_P_F_L_ ;

R : Distance from the initial level to the R position

P : Dwell time at the bottom of the hole

F : Cutting feedrate

L : Number of repetitions

Rigid tapping

G84.2X_C_Z_R_P_F_L_S_ ;

R : Distance from the initial level to the R position

P : Dwell time at the bottom of the hole

F : Cutting feedrate

L : Number of repetitions

S : Spindle speed

Boring cycle

G85X_C_Z_R_F_L_ ; or G89X_C_Z_R_P_F_L_ ;

R : Distance from the initial level to the R position

P : Dwell time at the bottom of the hole

F : Cutting feedrate

L : Number of repetitions

Cancel

G80 ;

Explanations

- Address

For this CNC tape format, the address used to specify the number of repetitions is K. For the Series 15 tape format, it is L.

● **G code**

Some G codes are valid only for this CNC tape format or Series 15 tape format. Specifying an invalid G code results in P/S alarm No. 10 being generated.

G codes valid only for the Series 15 tape format	G81, G82, G83.1, G84.2
G codes valid only for the Series 16/18/160/180 tape format	G87, G88

● **Positioning plane and drilling axis**

For this CNC tape format, the positioning plane and drilling axis are determined according to the G code for the canned cycle used.

For the Series 15 tape format, the positioning plane and drilling axis are determined according to G17/G19.

The drilling axis is the basic axis (Z-axis or X-axis) that does not lie in the positioning plane.

G code	Positioning plane	Drilling axis
G17	XY plane	Z-axis
G19	YZ plane	X-axis

Resetting bit 1 (FXY) of parameter No. 5101 enables fixing of the drilling axis to the Z-axis.

● **Details of data specifying machining**

Data for the canned cycle is specified as follows:

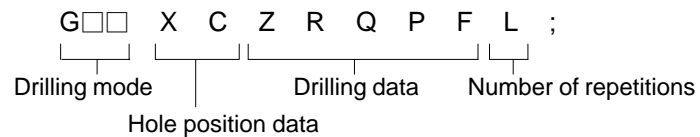

Setting	Address	Explanation
Drilling mode	G□□	Canned drilling cycle G code
Hole position data	X/U (Z/W) C/H	Incremental or absolute value used to specify the hole position
Drilling mode	Z/W (X/U)	Incremental or absolute value used to specify the distance from the R position to the bottom of the hole
	R	Incremental value used to specify the distance from the initial level to the R position, or absolute value used to specify the R position. Which to use depends on bit 6 of parameter No. 5102 and the G code system being used.
	Q	Incremental value used to specify the depth of cut in each G83 or G83.1 cycle with radius programming.
	P	Dwell time at the bottom of the hole. The relationship between the dwell time and the specified value is the same as that for G04.
	F	Cutting feedrate
Number of repetitions	L	Number of repetitions for a sequence of cutting operations. If L is not specified, it is assumed to be 1.

● **Specifying the R position**

The R position is specified as an incremental value for the distance between the initial level to the R position. For the Series 15 tape format, the parameter and the G code system used determine whether an incremental or absolute value is to be used to specify the distance between the initial level and the R position.

If bit 6 (RAB) of parameter No. 5102 is 0, an incremental value is always used. If it is 1, the type of value used depends on the G code system used. When G code system A is used, an absolute value is used. When G code system B or C is used, an absolute value is used in G90 mode, and an incremental value is used in G91 mode.

Series 15 tape format			Series 16/18/160/180 tape format
Bit 6 of parameter No. 5102 = 1		Bit 6 of parameter No. 5102 = 0	
G code system			Incremental
A	B, C		
Absolute	G90	G91	
	Absolute	Incremental	

● **Details of the canned cycle**

The correspondence between the G codes and this CNC tape format or Series 15 tape format is listed below. This list also provides notes on dwell during a canned cycle.

No. G□□ (Use) This CNC command format

- 1. G81 (Drilling cycle) G83 (G87) P0 <Q not specified>**
No dwelling
- 2. G82 (Drilling cycle) G83 (G87) P <Q not specified>**
The tool always dwells at the bottom of the hole.
- 3. G83 (Peck drilling cycle) G83 (G87) <Type B>**
If the block contains a P command, the tool dwells at the bottom of the hole.
- 4. G83.1 (Peck drilling cycle) G83 (G87) <Type A>**
If the block contains a P command, the tool dwells at the bottom of the hole.
Note) Either type A or B is selected according to bit 2 (RTR) of parameter No. 5101.
- 5. G84 (Tapping) G84 (G88)I**
If the block contains a P command, the tool dwells after it reaches the bottom of the hole and after it is retracted to the R position.
- 6. G84.2 (Rigid tapping) M29 S_ G84 (G88)**
If the block contains a P command, the tool dwells before the spindle starts rotating in reverse at the bottom of the hole and before it starts rotating in the normal direction at the R position.
- 7. G85 (Boring cycle) G85 (G89) P0**
No dwelling
- 8. G89 (Boring cycle) G85 (G89) P_**
The tool always dwells at the bottom of the hole.

● **Clearance d for G83 and G83.1**

Parameter No. 5114 determines clearance d for G83 and G83.1.

● **Dwell with G83 and G83.1**

For Series 15-T, G83 or G83.1 does not cause the tool to dwell. For the Series 15 tape format, the tool dwells at the bottom of the hole only if the block contains a P address.

● **Dwelling with G84 and G84.2**

In Series 15-T, G84/G84.2 causes the tool to dwell before the spindle starts rotating in either the normal or reverse direction, according to the corresponding parameter setting. For the Series 15 tape format, when the block contains a P address, the tool dwells at the bottom of the hole and at the R position before the spindle starts rotating either in the normal or reverse direction.

● **Rigid tapping**

For the Series 15 tape format, rigid tapping can be specified by using the methods listed below:

Format	Condition (parameter), comment
G84.2 X_ Z_ R_ ...S**** ;	Setting (F10/F11) = 1
S**** ; G84.2 X_ Z_ R_ ;	
M29 S**** ; G84 X_ Z_ R_ ;	* Common to Series 16 format
M29 S**** G84 X_ Z_ R_ ;	
G84 X_ Z_ R_ S**** ;	G84 is made a G code for rigid tapping. Bit 0 (G84) of parameter No. 5200 = 1 * Common to Series 16 format
S**** ; G84 X_ Z_ R_ ;	

● **Diameter or radius programming**

Specifying 1 for bit 7 (RDI) of parameter No. 5102 causes the canned cycle R command diameter or radius programming mode in the Series 15 tape format to match the diameter or radius programming mode for the drilling axis.

● **Disabling the Series 15 format**

Specifying bit 3 (F16) of parameter No. 5102 disables the Series 15 tape format. This applies only to the canned drilling cycle. However, the number of repetitions must be specified by using the L address.

CAUTION
Setting bit 3 (F16) of parameter No. 5102 to 1 overrides bits 6 (RAB) and 7 (RDI) of parameter No. 5102; both settings are assumed to be 0.

Limitations

● **C-axis as the drilling axis**

It is impossible to use the C-axis (the third axis) as a drilling axis. So, specifying G18 (ZX plane) generates P/S alarm No. 28 (plane selection command error).

● **Clamping the C-axis**

For the Series 15 tape format, it is impossible to specify an M code for clamping the C-axis.

18

FUNCTIONS FOR HIGH SPEED CUTTING



18.1 HIGH SPEED CYCLE CUTTING

This function can convert the machining profile to a data group that can be distributed as pulses at high-speed by the macro compiler and macro executor. The function can also call and execute the data group as a machining cycle using the CNC command (G05 command).

This function is applied to 1-path lathe control.

Format

G05 P10000 L000 ;

P10000 is number of the machining cycle to be called first:

P10001 to P10999

L000 is repetition count of the machining cycle

(L1 applies when this parameter is omitted.) :

L1 to L999

Call and execute the data for the high speed cutting cycle specified by the macro compiler and macro executor using the above command.

Cycle data can be prepared for up to 999 cycles. Select the machining cycle by address P. More than one cycle can be called and executed in series using the cycle connection data in the header.

Specify the repetition count of the called machining cycle by address L. The repetition count in the header can be specified for each cycle.

The connection of cycles and their repetition count are explained below with an example.

Example) Assume the following:

Cycle 1 Cycle connection data 2 Repetition count 1

Cycle 2 Cycle connection data 3 Repetition count 3

Cycle 3 Cycle connection data 0 Repetition count 1

G05 P10001 L2 ;

The following cycles are executed in sequence:

Cycles 1, 2, 2, 2, 3, 1, 2, 2, 2, and 3

NOTE

- 1 An alarm is issued if the function is executed in the G41/G42 mode.
- 2 Single block stop, dry run/feedrate override, automatic acceleration/deceleration and handle interruption are disabled during high-speed cycle machining.

Alarms

Alarm number	Descriptions
115	The contents of the header are invalid. This alarm is issued in the following cases. <ol style="list-style-type: none">1. The header corresponding to the number of the specified call machining cycle was not found.2. A cycle connection data value is not in the valid range (0 to 999).3. The number of data items in the header is not in the valid range (1 to 32767).4. The first variable No. for storing data in the executable format is not in the valid range (#20000 to #85535).5. The last variable No. for storing data in the executable format exceeds the limit (#85535).6. The first variable No. for start data in the executable format overlaps with a variable No. used in the header.
178	High-speed cycle machining was specified in the G41/G42 mode.
179	The number of control axes specified in parameter 7510 exceeds the maximum number.

18.2 DISTRIBUTION PROCESSING TERMINATION MONITORING FUNCTION FOR THE HIGH-SPEED MACHINING COMMAND (G05)

During high-speed machining, the distribution processing status is monitored. When distribution processing terminates, P/S alarm No. 000 and P/S alarm No. 179 are issued upon completion of the high-speed machining command (according to the setting of ITPDL (bit 7 of parameter No. 7501)).

These P/S alarms can be canceled only by turning off the CNC power.

Explanations

- High-speed machining command
- Distribution processing termination

High-speed machining using the high-speed remote buffer A function, high-speed remote buffer B function, and high-speed cycle function based on the G05 command

Failure to perform normal distribution processing because distribution processing required for high-speed machining exceeded the CNC processing capacity, or because distribution data sent from the host was delayed for some reason while the high-speed remote buffer A or G function was being used

Number	Message	Contents
000	PLEASE TURN OFF POWER	During high-speed machining, distribution processing was terminated. Related parameters: Remote buffer transfer baud rate (parameter No. 133)
179	PARAM. (NO. 7510) SETTING ERROR	Number of controlled axes in high-speed machining (parameter No. 7150) High-speed axis selection during high-speed machining (bit 0 of parameter No. 7510)

18.3 ADVANCE PREVIEW CONTROL (G08)

This function is designed for high-speed precise machining. With this function, the delay due to acceleration/deceleration and the delay in the servo system which increase as the feedrate becomes higher can be suppressed.

The tool can then follow specified values accurately and errors in the machining profile can be reduced.

This function becomes effective when advanced preview control mode is entered.

For details, refer to the relevant manual published by the machine tool builder.

Format

G08 P_

P1 : Turn on advanced preview control mode.

P0 : Turn off advanced preview control mode.

Explanations

- **Available functions**

In advanced preview control mode, the following functions are available:

- (1) Linear acceleration/deceleration before interpolation
- (2) Automatic corner deceleration function
- (3) Feedrate cramp function by arc radins

For the function of (1) above, a special parameter for the advanced preview control mode is provided.

- **Reset**

Advanced preview control mode is canceled by reset.

Notes

NOTE

- 1 If a block without a move command is encountered in the advanced preview control mode, the tool decelerates and stops in the previous block.
- 2 If a move block in the advanced preview control mode contains an M, S, or T code, the tool decelerates and stops in that block.
- 3 If a one-shot G code such as G04 is specified in the advanced preview control mode, the tool decelerates and stops in the previous block.
- 4 If an axial machine lock signal (MLK1 to MLK8) is set on or off in the advanced preview control mode, acceleration/deceleration is not carried out on the axis on which the machine lock is performed.
- 5 The automatic corner override in the advanced preview control mode can change just the internal arc cutting speed.
- 6 If an overtravel alarm occurs in the advanced preview control mode, the tool decelerates and stops after the alarm occurs. That is, the tool overruns by the deceleration distance.
- 7 If the feed per revolution command is specified in the advanced preview control mode, the spindle speed can be changed up to 30000 min⁻¹.
- 8 If a feed per minute block is followed or preceded by a feed per revolution block in the advanced preview control mode, the tool decelerates and stops in the previous block.

Limitations

- **G08 command**

Specify G08 code only in a block.

- **Threading**

Because this function involves automatic velocity control, the tool decelerates in a corner, automatically changing the depth of cut, even in the feed per minute mode. Therefore, this function cannot be used for threading. Automatic deceleration is performed also in the feed per revolution mode.

- **Functions that cannot be specified in the advanced preview control mode**

In the advanced preview control mode, some functions cannot be specified. When specifying any of those functions, cancel the advanced preview control mode in advance. After specifying the function, select the advanced preview control mode again. The table below indicates the applicability of the functions.

Function name	Applicability
Canned cycle for grinding	▲
Hypothetical axis interpolation	▲
8-digit program number preceded by O	○
Rapid traverse bell-shaped acceleration/deceleration	○
Dual position feedback	○

Function name	Applicability
Learning function	▲
Look-ahead repetition control	▲
Polygon between spindles	▲
Abnormal load detect function	○
Chuck/tailstock barrier	▲
PMC axis control velocity command function	▲
Corner rounding	○
Butt-type reference position setting	○
Circular threading	▲
Tandem control	○
C executor + macro executor	○
Motor velocity signal output	○
Additional C executor memory	○
Two Floppy Cassette control	○
Main CPU custom software capacity	○
Sub CPU custom software capacity	○
Straightness compensation	○
Simple spindle synchronization	○
Stroke limit check before movement	▲
Manual linear/circular interpolation	○
Three/four spindle serial outputs	○
Third/fourth spindle orientation	○
Third/fourth spindle output selection	○
Controlled axis count specification (sub side)	○
Controlled axis expansion	○
Controlled axis count specification	○
Simultaneous controlled axis expansion	○
Axis control by PMC	▲ (*1)
Increment system 1/10	○
Linear acceleration/deceleration after cutting feed interpolation	○
Axis removal	○
Feedrate second override	○

Function name	Applicability
Linear acceleration/deceleration before cutting feed interpolation	○
Polar coordinate interpolation	▲
Cylindrical interpolation	▲
Polygon turning	▲
Helical interpolation	○
Tool retract & return	▲
Threading retract	▲
Continuous threading	▲
Variable-lead threading	▲
Rigid tapping	▲
Bell-shaped acceleration/deceleration after cutting feed interpolation	○
Third/fourth reference position return	○
Floating reference position return	○
High-speed cycle cutting	▲
Axis recomposition	▲
Balance cut	▲
Single manual handle control	○
Double manual handle control	○
Handle interrupt	▲
Program restart	▲
Tool post interference check	▲
Expanded stored stroke check	▲
Stored pitch error compensation	○
External deceleration	○
Simple synchronization control	▲
Sequence number collation stop	○
Position switch	▲
Feed stop	▲
High-speed skip function	▲
Multistage skip function	▲
S serial output	○
Spindle positioning	▲

Function name	Applicability
Cs contour control	▲ (*2)
First spindle orientation	○
First spindle output selection	○
Constant surface speed control	○
Actual spindle speed output	○
Spindle speed fluctuation detection	○
Spindle synchronization control	○
Multi-spindle control	○
S analog output	○
Second spindle orientation	○
Second spindle output selection	○
Direct drawing dimension programming	○
Special G code	○
Programmable data input	○
Custom macro B	○
Interrupt-type custom macro	▲
Chamfer, corner rounding	○
Inch/metric selection	○
Multiple repetitive canned cycle	○
Canned cycle for drilling	○
Play back	○
Mirror image double turret	○
F15 tape format	○
Graphic conversation	○
Pattern data input	○
Additional custom macro common variable	○
Macro executor	○
Multiple repetitive canned cycle 2	○
Coordinate system rotation	○
Workpiece coordinate system	○
Reader/punch control 1	○
Reader/punch control 2	○
External control of I/O device	○

Function name	Applicability
Remote buffer	○
High-speed remote buffer A	▲
DNC1 control	○
DNC2 control	○
External tool compensation	○
External message	○
External machine zero point shift	○
External data input	○
Angular-axis control	▲
Workpiece coordinate system preset	○
Second auxiliary function	○
B-axis control	▲
M code group check	○
Reference position shift	○
Arbitrary axis/angular-axis control	▲
Additional tool compensation A (32 items)	○
Additional tool compensation B (64 items)	○
Additional tool compensation C (99 items)	○
Tool-nose radius compensation	○
Tool geometry compensation and wear compensation	○
Automatic tool compensation	▲
Direct input of offset value measurement B	○
Y-axis offset	○
Tool life management	○
Additional tool life management (128 combinations)	○
40-m part program storage	○
80-m part program storage	○
160-m part program storage	○
320-m part program storage	○
640-m part program storage	○
1280-m part program storage	○
2560-m part program storage	○
5120-m part program storage	○

Function name	Applicability
Additional registered programs A (125 programs)	○
Additional registered programs B (200 programs)	○
Additional registered programs C (400 programs)	○
Additional registered programs D (1000 programs)	○
Additional optional block skip	○
Background editing	○
Expanded tape editing	○
Software operator's panel	○
General switches of software operator's panel	○
Machining time stamp	○
Japanese-language display	○
German/French-language display	○
Chinese-language display	○
Italian-language display	○
Korean-language display	○
Spanish-language display	○
Display of run time and parts count	○
Graphic display	○
Floppy Cassette directory display	○
Feed per revolution	○
Skip function (G31)	▲
Low-speed reference position return (G28)	▲
Torque limit skip	▲
Threading	▲

<Applicability>

- : The function can be used in the look-ahead control mode.
- ▲ : The function cannot be used in the look-ahead control mode.
When using the function, cancel the look-ahead control mode.

NOTE

- 1 PMC axis control can be enabled only for advance feed forward.
- 2 Cs contour control can be performed in the look-ahead control mode if the G8S bit (bit 5 of parameter 1602) is set accordingly.

19

AXIS CONTROL FUNCTION



19.1 POLYGONAL TURNING

Polygonal turning means machining a polygonal figure by rotating the workpiece and tool at a certain ratio.

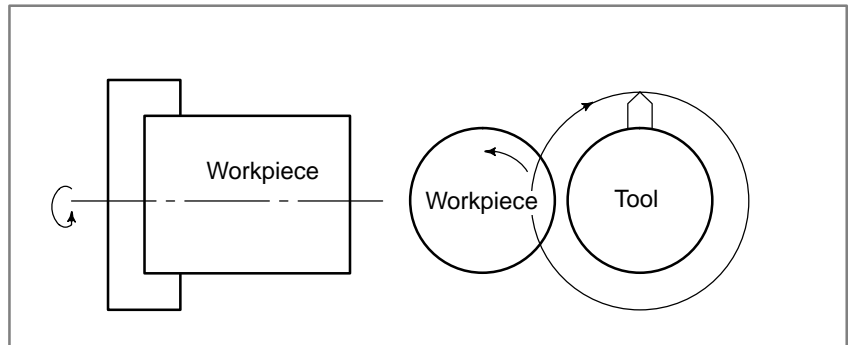

Fig. 19.1 (a) Polygonal turning

By changing conditions which are rotation ratio of workpiece and tool and number of cutters, the machining figure can be changed to a square or hexagon. The Machining time can be reduced as compared with polygonal figure machining using C and X axes of the polar coordinate. The machined figure however, is not exactly polygonal. Generally, polygonal turning is used for the heads of square and/or hexagon bolts or hexagon nuts.

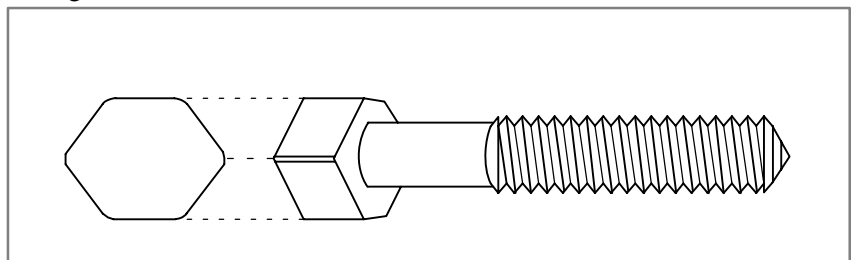

Fig. 19.1 (b) Hexagon bolt

Format

G51.2(G251)	P_Q_;	Rotation ratio of spindle and Y axis
	P,Q:	Specify range:Integer 1 to 9 for both P and Q
		When Q is a positive value, Y axis makes positive rotation.
		When Q is a negative value, Y axis makes negative rotation.

Explanations

Tool rotation for polygonal turning is controlled by CNC controlled axis. This rotary axis of tool is called Y axis in the following description.

The Y axis is controlled by G51.2 command, so that the rotation speeds of the workpiece mounted on the spindle (previously specified by S-command) and the tool become the specified ratio.

(Example) Rotation ratio of workpiece (spindle) to Y axis is 1:2, and the Y axis makes positive rotation.

G51.2P1Q2;

When simultaneous start is specified by G51.2, the one-rotation signal sent from the position codes set on the spindle is detected. After this detection, the Y axis rotation is controlled according to the rotation ratio (P:Q) while synchronizing with the spindle speed. Namely, the Y axis rotation is controlled so that the spindle and Y axis stand in a relation of P:Q. This relation will be maintained until the polygonal turning cancel command is executed (G50.2 or reset operation). The direction of Y axis rotation is determined by the code

Q and not affected by the direction of the Iposition coder rotation.

Synchronization of the spindle and Y axis is canceled by the following command:

G50.2(G250);

When G50.2 is specified, synchronization of the spindle and Y axis is canceled and the Y axis stops.

This synchronization is also canceled in the following cases:

- i) Power off
- ii) Emergency stop
- iii) Servo alarm
- iv) Reset (external reset signal ERS, reset/rewind signal RRW, and RESET key on the MDI panel)
- v) Occurrence of P/S alarm Nos. 217 to 221

Example

G00X100.0Z20.0S1000.0M03 ; Workpiece rotation speed 1000rpm

G51.2P1 Q2 ; Tool rotation start (tool rotation speed 2000rpm)

G01X80.0 F10.0 ; X axis infeed

G04X2. ;

G00X100.0 ;X axis escape

G50.2 ; Tool rotation stop

M05 ; Spindle stop Specify **G50.2** and **G51.2** always in a single block.

● **Principle of Polygonal Turning**

The principle of polygonal turning is explained below. In the figure below the radius of tool and workpiece are A and B, and the angular speeds of tool and workpiece are α and β . The origin of XY cartesian coordinates is assumed to be the center of the workpiece.

Simplifying the explanation, consider that the tool center exists at the position

$P_0 (A, 0)$ on the workpiece periphery, and the tool nose starts from position $P_{t0}(A-B, 0)$.

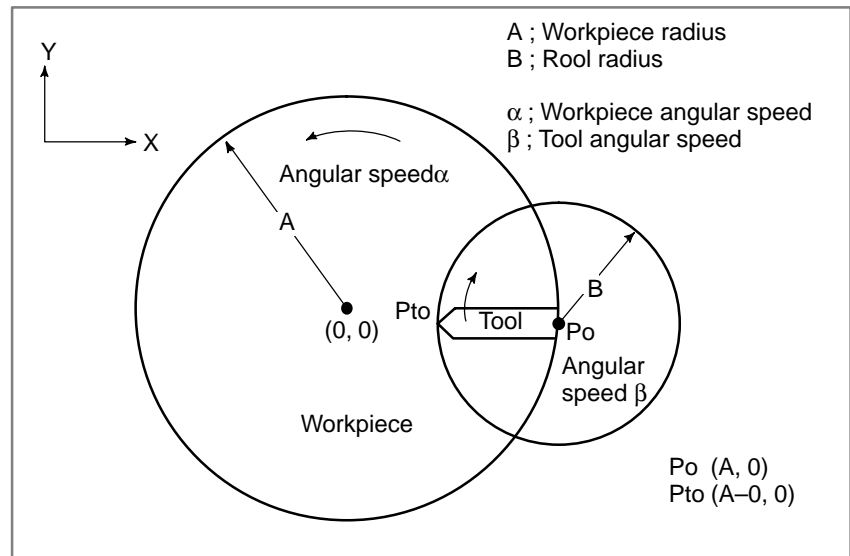

In this case, the tool nose position $P_t (X_t, Y_t)$ after time t is expressed by equation 1:

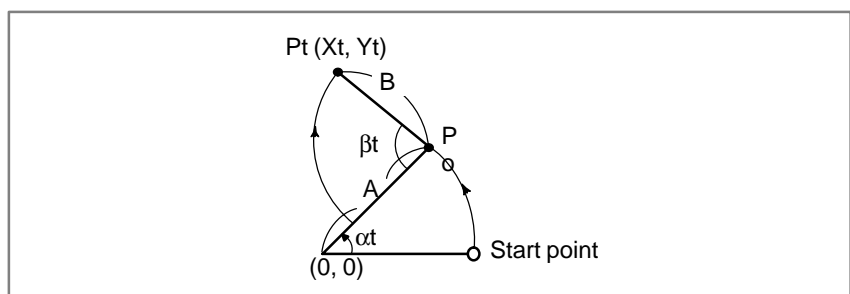

$$X_t = A \cos \alpha t - B \cos(\beta - \alpha)t$$

(Equation 1)

$$Y_t = A \sin \alpha t + B \sin(\beta - \alpha)t$$

Assuming that the rotation ratio of workpiece to tool is 1:2, namely, $\beta = 2\alpha$,

equation 1 is modified as follows

$$X_t = A \cos \alpha t - B \cos \alpha t = (A - B) \cos \alpha t$$

(Equation 2)

$$Y_t = A \sin \alpha t + B \sin \alpha t = (A + B) \sin \alpha t$$

Equation 2 indicates that the tool nose path draws an ellipse with longer diameter $A+B$ and shorter diameter $A-B$.

Then consider the case when one tool is set at 180° symmetrical positions, for a total of two. It is seen that a square can be machined with these tools as shown below.

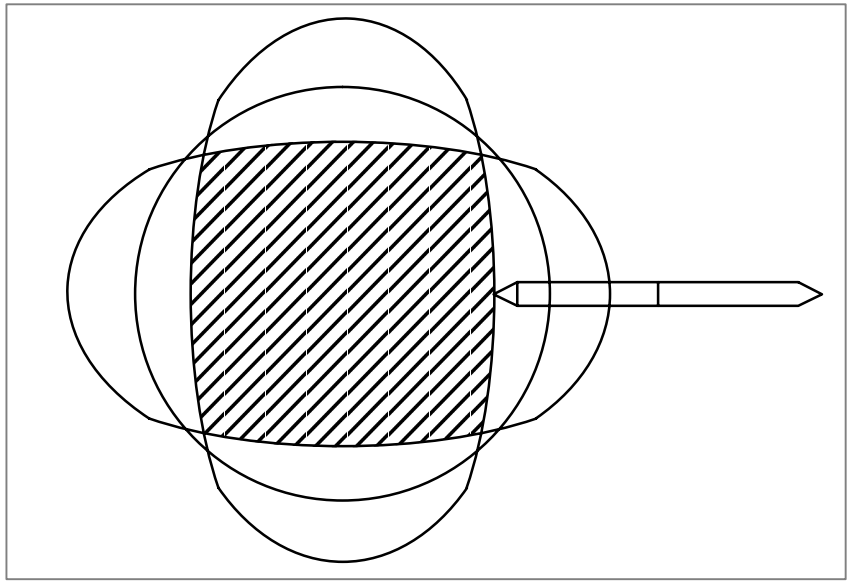

If three tools are set at every 120° , the machining figure will be a hexagon as shown below.

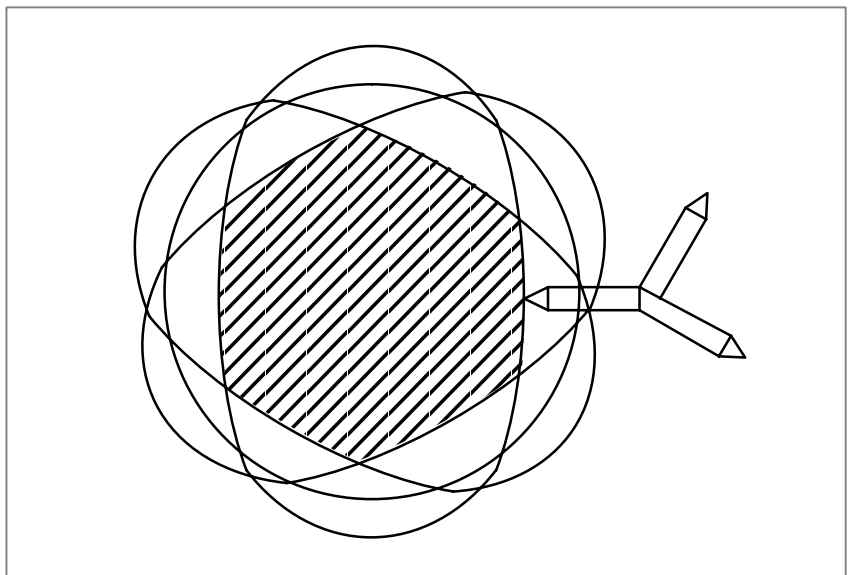

WARNING

- 1 For the maximum speed of the tool, see the instruction manual supplied with the machine. Do not specify a spindle speed higher than the maximum tool speed or a ratio to the spindle speed that results in a speed higher than the maximum tool speed.
- 2 The starting point of the threading process becomes inconsistent when performed during synchronous operation.
Cancel the synchronizing by executing G50.2 when threading.
- 3 The following signals become either valid or invalid in relation to the Y axis in synchronous operation.
Valid signals in relation to Y axis:
 machine lock
 servo off
Invalid signals in relation to Y axis:
 feed hold
 interlock
 override
 dry run
(During a dry run, however, there is no wait for a revolution signal in the G51.2 block.)

NOTE

- 1 The Y axis, unlike the other controlled axes, cannot be specified a move command as Y—. That is, an axis move command is unnecessary for the Y axis. Because, when G51.2 (polygonal turning mode) is specified, it is only necessary to control the Y axis so that the tool rotates at a certain ratio to the spindle rotation speed.
However, only the reference point return command (G28V0;) can be specified since the Y axis rotation is stopped at the unstable position when G50.2 (polygonal turning mode cancel command) is specified. If the tool rotation start position is unstable, a problem may occur, for example, when the same figure is machined with a finishing tool after once machined with a roughing tool.
Specification of G28V0; for Y axis is equal to the orientation command for the spindle. In the other axes, unlike the manual reference point return, G28 usually makes reference point return without detecting the deceleration limit. However, with G28V0;, for the Y axis, reference point return is executed by detecting the deceleration limit, like manual reference point return.
To machine a workpiece into the same figure as the previous one, the tool and the spindle must be in the same position as the previous time when the tool starts rotating. The tool is set start rotation when the one-rotation signal of the position coder set on the spindle is detected.
- 2 The Y axis used to control tool rotation for polygonal turning uses the 4th axis. However, by setting parameters, (No. 7610) the 3rd axis may also be used. In this case, that axis must be named C axis.
- 3 Among the position display of the Y axis, the display for the machine coordinate value (MECHINE) will change from a range of 0 to the parameter setting (the amount of movement per revolution) as the Y axis moves.
Absolute or relative coordinate values are not renewed.
- 4 An absolute position detector cannot be set on the Y axis.
- 5 Manual continuous feed or handle feed is invalid when the Y axis is in synchronous operation.
- 6 The Y axis in synchronous operation is not included in the number of axis controlled simultaneously.

19.2 ROTARY AXIS ROLL-OVER

The roll-over function prevents coordinates for the rotation axis from overflowing. The roll-over function is enabled by setting bit 0 of parameter 1008 to 1.

19.2.1 Rotary Axis Roll-over

Explanations

For an incremental command, the tool moves the angle specified in the command. For an absolute command, the coordinates after the tool has moved are values set in parameter No. 1260, and rounded by the angle corresponding to one rotation. The tool moves in the direction in which the final coordinates are closest when bit 1 (ROAx) of parameter No. 1008 is set to 0. Displayed values for relative coordinates are also rounded by the angle corresponding to one rotation when bit 2 (ROAx) of parameter No. 1008 is set to 1

Examples

Assume that axis C is the rotating axis and that the amount of movement per rotation is 360.000 (parameter No. 1260 = 360000). When the following program is executed using the roll-over function of the rotating axis, the axis moves as shown below.

C0 ;	Sequence number	Actual movement value	Absolute coordinate value after movement end
N1 C-150.0 ;	N1	-150	210
N2 C540.0 ;	N2	-30	180
N3 C-620.0 ;	N3	-80	100
N4 H380.0 ;	N4	+380	120
N5 H-840.0 ;	N5	-840	0

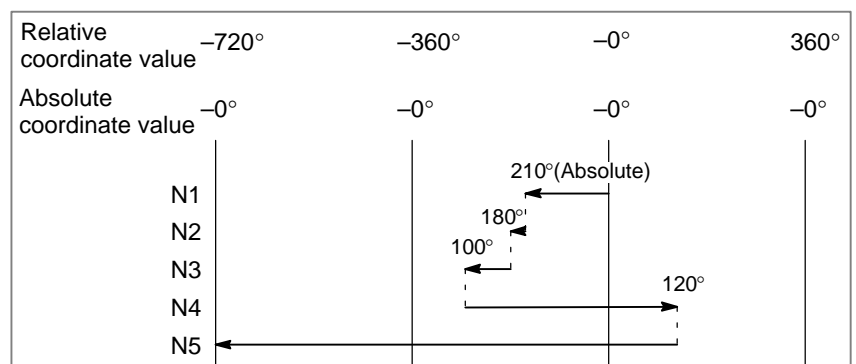

19.2.2 Rotary Axis Control

This function controls a rotary axis as specified by an absolute command. With this function, the sign of the value specified in the command is interpreted as the direction of rotation, and the absolute value of the specified value is interpreted as the coordinates of the target end position.

Explanations

This function is valid when rotary axis roll-over is enabled (ROAx bit (bit 0 of parameter 1008) is set to 1).

If the RAAx bit (bit 3 of parameter 1008) is set to 1, an absolute command specified for the roll-over rotary axis is interpreted as follows: The sign and absolute value of the value specified in the command represent the direction of rotation and the end position of movement respectively.

If the RAAx bit (bit 3 of parameter 1008) is set to 0, the setting by the RABx bit (bit 1 of parameter 1008) becomes significant.

Notes

NOTE

- 1 This function can be used only when the corresponding option is provided.
- 2 This function is valid for a roll-over rotary axis.
- 3 If the RAAx bit (bit 3 of parameter 1008) is set to 1, the RABx bit (bit 1 of parameter 1008) is ignored. To select a rotary motion of a shorter travel distance, set both RAAx and RABx to 0.
- 4 This function is not supported when the machine coordinate system of the PMC axis control function is selected.

19.3 SIMPLE SYNCHRONIZATION CONTROL

The simple synchronization control function allows synchronous and normal operations on two specified axes to be switched, according to an input signal from the machine.

For a machine with two tool posts that can be independently driven with different controlled axes, this function enables the operations described below.

This section describes the operations of a machine having two tool posts, both of which can be independently operated along the X-axis and Y-axis. If your machine uses other axes for the same purpose, substitute the corresponding axis names for X and Y.

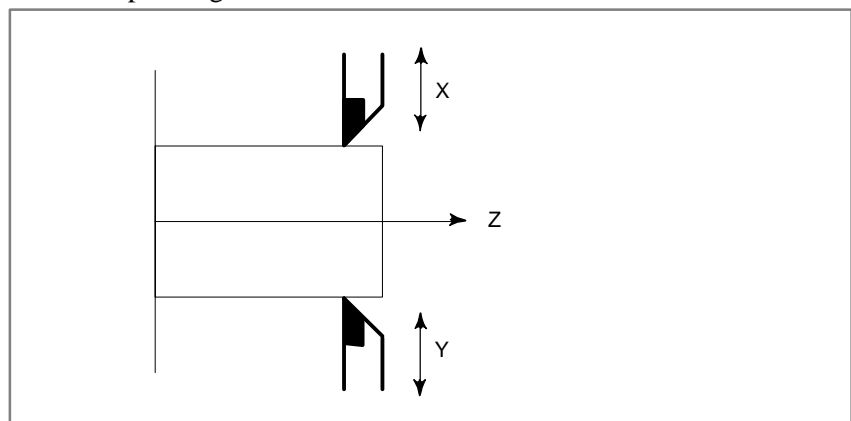

Fig. 19.3 Sample Axis Configuration of a Machine on which the Simple Synchronization Control Function is Executed

Explanations

- **Synchronous operation**

Synchronous operation is possible on a machine having two tool posts. In synchronous operation mode, movement on one axis can be synchronized with movement specified for another axis. The move command can be specified for one of the two axes, which is referred to as the master axis. The other axis, for referred synchronization with the master axis is maintained, is referred to as the slave axis. If the master axis is X and the slave axis is Y, synchronous operation on the X-axis (master axis) and Y-axis (slave axis) are performed according to Xxxxx commands issued for the master axis.

In synchronous operation mode, a move command specified for the master axis results in simultaneous operation of the servo motors of the master and slave axes.

In this mode, synchronization error compensation is not performed. That is, any positioning error between the two servo motors is not monitored, nor is the servo motor of the slave axis adjusted to minimize any error. No synchronization error alarm is output. Automatic operations can be synchronized, but manual operations cannot.

- **Normal operation**

Normal operation is performed when different workpieces are machined on different tables. As with normal CNC control, move commands for the master and slave axes are specified with the addresses of those axes (X and Y). Move commands for the two axes can be specified in an identical block.

- 1 According to the Xxxxx command programmed for the master axis, movement is performed along the X-axis, as in normal mode.

- 2 According to the Yyyyy command programmed for the slave axis, movement is performed along the Y-axis, as in normal mode.
- 3 According to the Xxxxx Yyyyy command, simultaneous movements are performed along both the X-axis and Y-axis, as in normal mode. Both automatic and manual operations can be controlled, as in normal CNC control.

- **Switching synchronous and normal operations**

For details of how to switch the synchronous and normal operations, refer to the manual supplied by the machine tool builder.

- **Automatic reference position return**

If a command for automatic reference position return (G28), or return to the second, third, or fourth reference position (G30), is issued in synchronous operation mode, a reference position return is performed for the X-axis, and an identical movement is performed for the Y-axis. If this Y-axis movement agrees with a return to the reference position on the Y-axis, a lamp indicating that reference position return has been completed for the Y-axis also lights.

It is recommended, however, that G28 and G30 be specified in normal operation mode.

- **Checking automatic reference position return**

If a command for checking automatic reference position return (G27) is issued in synchronous operation mode, identical movements are performed for the X-axis and Y-axis.

If these X-axis and Y-axis movements correspond to returns to the reference positions on the X-axis and Y-axis, the lamps indicating that reference position return has been completed for the X-axis and Y-axis light. If not, an alarm is output.

It is recommended, however, that G27 be specified in normal operation mode.

- **Slave axis command**

If a move command is specified for the slave axis in synchronous operation mode, P/S alarm 213 is output.

- **Master and slave axes**

The master axis is defined in parameter 8311. The slave axis is specified by an external signal.

Limitations

- **Coordinate system setting and tool compensation**

If coordinate system setting or tool compensation causing a shift in the coordinate system is performed in synchronous operation mode, P/S alarm 214 is output.

- **External deceleration, interlock, machine lock**

In synchronous operation mode, the signal for external deceleration, interlock, or machine lock of the master axis only is valid. The corresponding slave axis signal is ignored.

- **Pitch error compensation**

Pitch error compensation and backlash compensation are performed separately for the master and slave axes.

- **Manual absolute switch**

In synchronous operation mode, the manual absolute switch must be set to on (ABS must be set to 1). If the switch is set to off, the correct slave axis movement may not be made.

- **Manual operation**

Manual operations cannot be synchronized.

19.4 SYNCHRONIZATION CONTROL

The synchronization control function enables the synchronization of movements on two axes. If a move command is programmed for one of those two axes (master axis), the function automatically issues the same command to the other axis (slave axis), thus establishing synchronization between the two axes. The parking state can be selected to suppress movement of the slave axis, even if a move command is specified for the master axis. If the parking state is used with the synchronization control function, the operation can be controlled as follows:

- 1 Synchronizes the movement on the slave axis with that of the master axis.
- 2 Performs slave axis movement according to the move command programmed for the master axis. However, the movement specified by the command is not made for the master axis itself (master parking).
- 3 Updates the slave axis coordinates according to the distance travelled along the master axis. However, no movement is made for the slave axis (slave parking).

When method 2 above is used, the following operation can be performed:

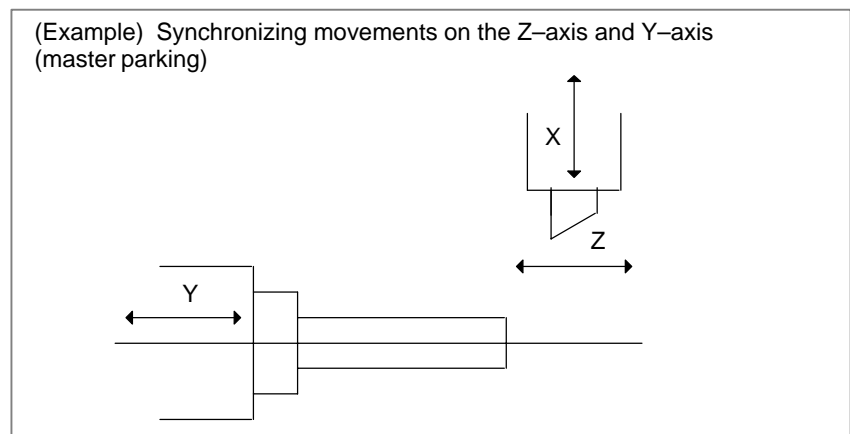

Movement is performed for the X-axis and Y-axis according to commands issued for the X-axis and Z-axis. (The Y-axis movement is synchronized with that of the Z-axis.) If the Z-axis is set to the parking state, the coordinates on the Z-axis and Y-axis are updated.

As the coordinates on the Z-axis and Y-axis are always updated, the coordinate system need not be reset when the synchronization status is changed. A move command can be executed immediately after the status is changed.

NOTE

- 1 In the synchronization control described above, an identical move command is simultaneously output for two servo processing systems. Positional error between the two servo motors is not monitored, nor is either servo motor adjusted to minimize the error. That is, synchronization error compensation is not carried out.
- 2 The method used to specify the synchronization control function varies with the machine tool builder. For details, refer to the manual supplied by the machine tool builder.

19.5 B-AXIS CONTROL (G100, G101, G102, G103, G110)

This function sets an axis (B-axis) independent of the basic controlled axes X_1 , Z_1 , X_2 , and Z_2 and allows drilling, boring, or other machining along the B-axis, in parallel with the operations for the basic controlled axes. The X_2 and Z_2 axes can be used in two-path control mode.

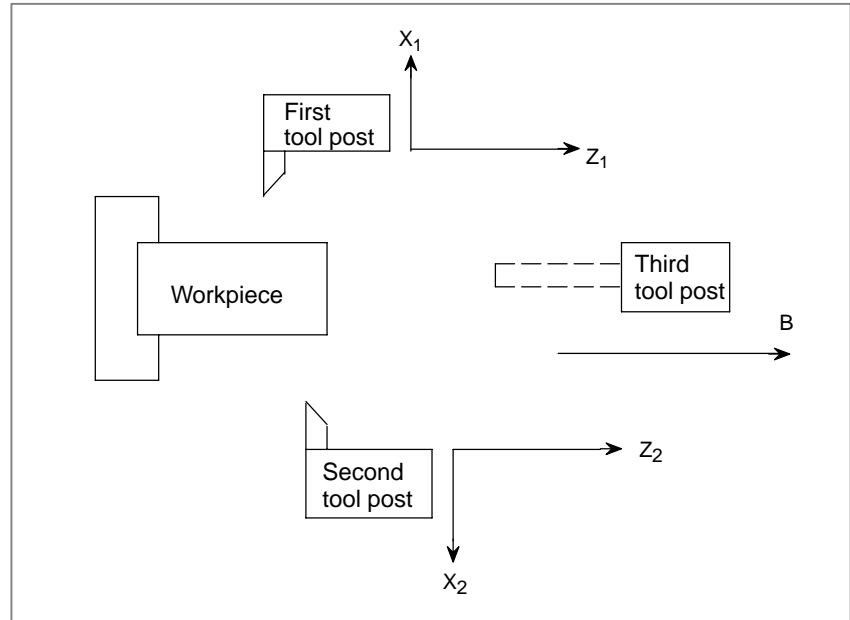

Format

- Registering operation programs

G101-G100 : Starts registering the first program.
G102-G100 : Starts registering the second program.
G103-G100 : Starts registering the third program.
G100 : Ends registering of the programs.

Three operations (programs) on the B-axis can be registered. (In two-path control mode, three programs can be registered for each tool post.) The B-axis operation program must be specified in the blocks between G101, G102, or G103 and G100, allowing it to be discriminated from the normal NC program. The registered operation is started upon executing the corresponding M code, described below.

```
O1234 ;
:
:      Normal NC program
G101 ;- ----- Starts registering of a B-axis
:      B-axis operation program          operation program.
:
G100 ; ----- Ends registering of the B-axis
:      Normal NC program                operation program.
:
M30 ;
```

Note) In the block of G101, G102, G103, or G100, specify no other codes.

- **Command used to start the operation**

To start an operation, the miscellaneous functions (M**) specified in parameters 8251 to 8253 are used.

Parameter 8251:

M code used to start operation of the first program

Parameter 8252:

M code used to start operation of the second program

Parameter 8253:

M code used to start operation of the third program

O1234 ;

⋮

M** ; -

⋮

M30 ;

Starts executing the registered B-axis operation. In subsequent blocks, the normal NC program and the B-axis operation program are executed in parallel. (** is specified in parameters 8251 to 8253.)

Example

O1234 ;

G50 X100. Z200. ;

G101 ;

G00 B10. ;

M03 ;

G04 P2500 ;

G81 B20. R15. F500 ;

G28 ;

G100 ;

G00 X80. Z50. ;

G01 X45. F1000 ;

⋮

G00 X10. ;

M** ;

G01 Z30. F300 ;

⋮

M30 ;

① Starts registering of an operation program.

② Blocks of the B-axis operation program

③ Ends registering of the operation program.

④ Command used to start the programmed operation

① to ③ : Specify the B-axis operation program in blocks between G101, G102, or G103 and G100. The program is registered in program memory.

④ : Starts executing the B-axis operation registered with ① to ③ above. In subsequent blocks, the normal NC operation and the B-axis operation are executed in parallel. An M code of the miscellaneous function is used to start the B-axis operation. The M code, used to start the operation, is specified in parameters 8251 to 8253.

- **Single-motion operation**

G110 [operation command];

A single-motion operation for the B-axis can be specified and executed as shown above. Such an operation need not be registered as a special (first to third) program. Nor does it need to be by a special command, as described above.

Explanations

- **Specifying two-path control mode**

One of the following three two-path control modes can be selected:

- 1 B-axis control is executed for either tool post 1 or 2.
- 2 B-axis control is executed separately for tool posts 1 and 2.
- 3 Identical B-axis control is executed for tool posts 1 and 2.

The mode is selected according to the value specified for parameter 8250 for each tool post.

- **Codes that can be used in a B-axis operation program**

The following 13 G codes, and the M, S, and T codes of the miscellaneous functions, can be used in a B-axis operation program:

Code	Description
G00	Positioning (rapid traverse)
G01	Linear interpolation (cutting feed)
G04	Dwell
G28	Reference position return, automatic coordinate system setting
G80	Canned cycle, cancel
G81	Drilling cycle, spot drilling
G82	Drilling cycle, counterboring
G83	Peck drilling cycle
G84	Tapping cycle
G85	Boring cycle
G86	Boring cycle
G98	Feed per minute
G99	Feed per rotation
M**	Auxiliary function
S**	Auxiliary function
T**	Auxiliary function, tool offset

G28 (reference position return)

Unlike the normal G28 cycle, the G28 cycle for a B-axis operation does not include intermediate point processing. For example, the following cannot be specified:

```
G28 B99.9;
```

G80 to G86 (canned drilling cycle)

Of the canned drilling cycles supported by the FANUC Series 16 or Series 18 for machining centers, those cycles equivalent to G80 to G86 can be executed.

Data can be specified in the same way as for the FANUC Series 16 or Series 18 for machining centers, except for the following points:

1. The drilling position is not specified with X and Y.
2. The distance from point R to the bottom of the hole is specified with B.

3. All operations are executed in the initial level return mode.
4. The repetition count (K) cannot be specified.
5. In canned cycle mode, point R must be specified. (If point R is omitted, P/S alarm No. 5036 is output.)
6. The drilling start point (d) for the G83 (peck drilling) cycle is specified with parameter 8258.

G98, G99 (feed per minute, feed per rotation)

The MDF bit (bit 2 of parameter 8241) specifies an initial continuous-state G code for G110, or the G code to start registration of the operation program (G101, G102, G103).

When the MDF bit is set to 0, the initial continuous-state code is G98.

When the MDF bit is set to 1, the initial continuous-state code is G99.

Example)

When MDF is set to 0

G110 B100. F1000. ; 1000 mm/min

G110 G99 B100. F1 ; 1 mm/rev

NOTE

In two-path control mode, the system uses the actual spindle speed, calculated from the feedback signal output by the position coder connected to the tool post to which the controlled axis belongs.

M, S, and T codes (auxiliary functions)

According to a numeric value subsequent to address M, S, or T, the binary code and strobe signal are sent to the machine. The codes and signals for addresses M, S, and T are all output to an identical interface and can be used to control power-on or power-off of the machine. For this purpose, the axis control interface of the PMC is used, which differs from that used for the miscellaneous functions for the normal NC program. The following M codes, used to control the spindle, are automatically output during the G84 (tapping) or G86 (boring) cycle:

M03: Forward spindle rotation

M04: Reverse spindle rotation

M05: Spindle stop

T** to T (** + 9), where ** is the number specified in parameter 8257, are used as the codes of the auxiliary functions to adjust the tool offset.

Example)

T50 to T59 if parameter 8257 is set to 50

1. An M, S, or T code must not be specified in a block containing another move command. The M, S, and T codes must not be specified in an identical block.
2. Usually, normal NC operation and B-axis operation are independent of each other. Synchronization between operations can be established by coordinating the miscellaneous functions of the normal NC program and B-axis operation program.

```

(Normal NC operation) (Registered B-axis operation)
:
:
M11 ; G00 B111 ;
G01 X999 : G01 B222 ;
G28 Z777 ; G28 ;
M50 ; M50 ;
G00 X666 ; G81 B444 R111 F222 ;
:
:
    
```

Upon receiving M50 of both the normal NC program and the B-axis program, the PMC ladder outputs the completion signals (FIN) for the two miscellaneous functions. G00 X666 of the normal NC program and G81 B444 R111 F222 of the B-axis program are executed simultaneously.

Custom macro

Custom macro variables (local variables, common variables, system variables #****) can be used in an operation program between G101, G102, or G103 and G100.

1. The value of the macro variable is calculated not from the data existing upon execution of the B-axis operation, but from the data existing at registration of the operation program.
2. An instruction that causes a branch to a location beyond the range of G101, G102, or G103 to G100 is processed without being checked.
3. In the two-path control mode, tool posts 1 and 2 use different macro variables.

● **Operation program**

When a new operation program is registered, the previous operation program is automatically deleted.

If an error is detected in an operation program to be registered, the program is initialized but is not registered.

● **Modal**

In the same way as a normal NC program, the B-axis operation program can use the following as modal data: modal G codes, F codes, and P, Q, and R codes in the canned cycle. These codes do not affect the modal information of the normal NC program. When a B-axis operation program is started (by G101, G102, or G103), the initial modal data is set for the program. It is not affected by the previous modal information.

Example)

```

:
G01 X10. F1000 ; ..... ①
G101 (G102, G103) ; ..... ②
B10. ; ..... ③
G01 B-10. F500 ; ..... ④
G100 ; ..... ⑤
X-10. ; ..... ⑥
:
    
```

Irrespective of the modal information for normal operation (G01 specified in block), block ③ specifies G00 if the MDG bit (bit 1 of parameter 8241) is set to 0, or G01 if the MDG bit is set to 1. Block ⑥ causes movement with F1000, specified in block 1.

- **Operation start command**

The MST bit (bit 7 of parameter 8240) specifies the method used to start the B-axis operation as described below:

If the MST bit is set to 1, the B-axis operation is started when the M code to start the operation is executed.

If the MST bit is set to 0, the B-axis operation is started when the M code used to start the operation is executed and the PMC outputs the miscellaneous function completion signal (FIN).

Up to five M codes for starting the programs can be stored. The programs corresponding to these M codes are executed in succession. (In two-path control mode, up to five codes can be stored for each tool post.)

Example)

When the first, second, and third programs are started by M40, M41, and M42, respectively

O1234. ;

:
:

M40 ; M code for starting the first program

M41 ; M code for starting the second program

M42 ; M code for starting the third program

M40 ; M code for starting the first program

M41 ; M code for starting the second program

:
:

M30 ;

As M41 is specified while the program started by M40 is being executed, the second program is automatically started upon termination of the first program.

M42, M40, and M41, specified during execution of the first program, are stored such that the corresponding programs are executed in the same order as that in which the M codes are specified.

If six or more M codes for starting the programs are specified while a program is being executed, P/S alarm 5038 is output.

In two-path control mode, the M code specified for tool post 1 starts the B-axis program registered for tool post 1. The M code specified for tool post 2 starts the B-axis program registered for tool post 2.

- **Specifying absolute or incremental mode**

The amount of travel along the B-axis can be specified in either absolute or incremental mode. In absolute mode, the end point of travel along the B-axis is programmed. In incremental mode, the amount of travel along the B-axis is programmed directly.

The ABS bit (bit 6 of parameter 8240) is used to set absolute or incremental mode. When the ABS bit is set to 1, absolute mode is selected. When the ABS bit is set to 0, incremental mode is selected. The mode is specified with this parameter when the program is registered.

● **Specifying a tool offset**

The T**; command shifts the end point of the specified B-axis travel, in either the positive or negative direction, by the amount specified with the B-axis offset screen. If this function is used to set the difference between the programmed tool position and actual tool position in machining, the program need not be modified to correct the tool position.

The value specified with parameter 8257 is assigned to the auxiliary function to cancel the offset. The subsequent nine numbers are assigned to the tool offset functions. These auxiliary function numbers are displayed on the B-axis offset screen. For details, see "OPERATION."

● **Single-motion operation**

If a G110 block is specified, a single-motion operation along the B-axis can be specified and executed. In single-motion operation mode, a single block results in a single operation. The single-motion operation is executed immediately provided if it is specified before the B-axis operation is started. If the operation is specified while a registered program is being executed, the operation is executed once that program has terminated.

After the specified single-motion operation has been executed, the next block is executed.

```

:
G110 G01 B100. F200 ;   Block for single-motion
                        operation along B-axis
G00 X100. Z20. ;
:
    
```

● **Program memory**

An operation program is registered in program memory as a series of different blocks of the move, dwell, auxiliary, and other functions. Program memory can hold a desired number of blocks, up to a maximum of 65535 blocks for each program. If the program memory contains no free space when an attempt is made to register a B-axis program, P/S alarm 5033 is output. Six blocks require 80 characters of program memory. A canned cycle (G81 to G86) is also registered as a series of blocks, such as travel and dwell.

The entire program memory is backed up by battery. The programs registered in program memory are thus retained even after the system power is turned off. After turning the system power on, the operation can be started simply by specifying the M code for starting the program.

Example)

```

:
G101 ;
G00 B10. ; ..... One block
G04 P1500 ; ..... One block
G81 B20. R50. F600 ; ..... Three blocks
G28 ; ..... One block
M15 ; ..... One block
G100 ;
:                                     (Total 7 blocks)
    
```

● **Reset**

When the NC is reset by pressing the MDI reset key or by the issue of an external reset signal, reset and rewind signal, or emergency stop, B-axis control is also reset. The PMC interface signal can reset only B-axis control. For details, refer to the manual supplied by the machine tool manufacturer.

- **PMC-controlled axis**

A B-axis operation can be executed only when the B-axis can be controlled by the PMC. For details, refer to the manual supplied by the machine tool builder.

Limitations

- **Single-motion operation**

1. Only a single-motion operation can be specified with G110.
 G110 G00 B100. ; OK
 G110 G28 ; OK
 G110 G81 B100. R150.0 F100 ; ... P/S alarm No. 5034
2. A canned cycle (G81 to G86), and other operations containing multiple motions, cannot be specified with G110.
 If an inhibited operation is specified, P/S alarm No. 5034 is output.
3. modal information specified with G110 does not affect the subsequent blocks. In the G110 block, the initial modal value specified at the start of the operation becomes valid, irrespective of the modal information specified the previous blocks.

Example)

When the MDG bit (bit 1 of parameter 8241) is set to 1 and the MDF bit (bit 2 of parameter 8241) is set to 1

```
G98 G00 X100. F1000 ; ..... (1)
G110 B200. F2 ; ..... (2)
X200. ; ..... (3)
G01 X200. ; ..... (4)
```

Block (2) instigates cutting feed (G01) at 2.0 mm/rev (G99).

Block (3) instigates rapid traverse (G00).

Block (4) instigates cutting feed (G01) at 1000 mm/min (G98).

4. During tool-tip radius compensation, two or more G110 blocks cannot be specified in succession. If such blocks are specified in succession, P/S alarm No. 504 is output. To specify two or more G110 blocks in succession for a B-axis operation, register the blocks as a program with G101, G102, or G103 and G100.

Examples

● **Absolute or incremental mode**

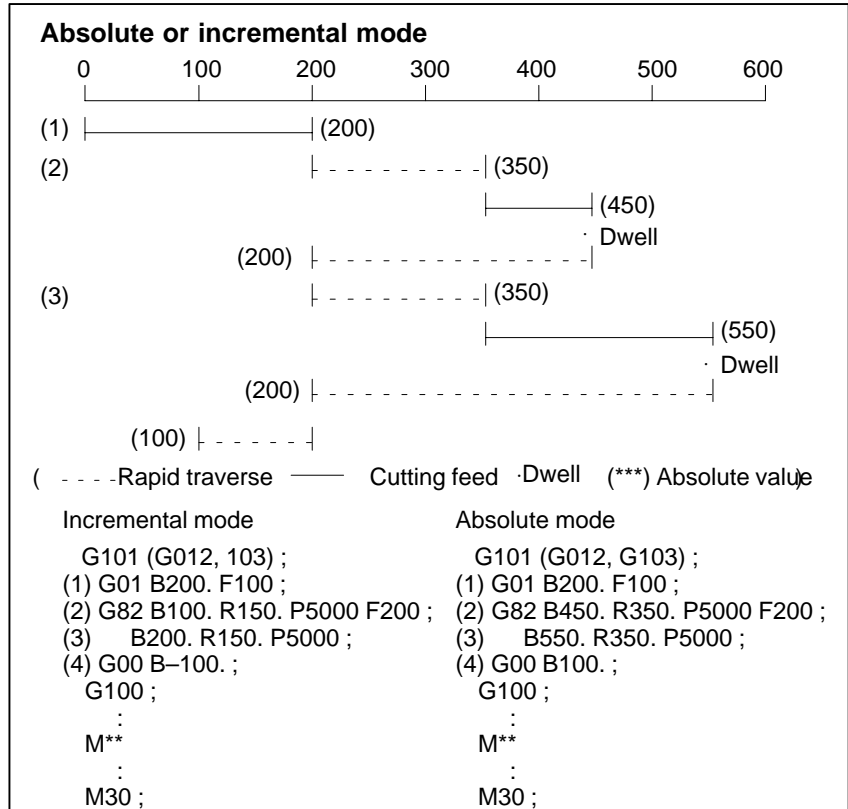

● **Tool posts 1 and 2**

If a single axis is used as the common B-axis of the two tool posts in two-path control, tool posts 1 and 2 share the B coordinate. For example, after program 1 for tool post 1 and program 2 for tool post 2 are executed in that order, the total travel along the B-axis appears to be +100.

```

<Program 1>
G101 ;
⋮
G00 B200. ; (Absolute mode)
G100 ;
⋮
M30 ;

<Program 2>
G101 ;
G00 B300. ; (Absolute mode)
⋮
G100 ;
⋮
M30 ;
    
```

● Tool offset

Example)
 When parameter 8257 is set to 50
 Auxiliary function used to cancel the offset: T50
 Auxiliary functions used to adjust a tool offset: T51 to T59

(Absolute mode)

(1) → (10)
 (2) → (20)
 (3) → (30)
 (4) → (25)
 (5) → (5)
 (6) → (0)

(Incremental mode)

(1) → (10)
 (2) → (20)
 (3) → (40)
 (4) → (35)
 (5) → (35)
 (6) → (30)

Program

```
G101 (G012, G103);
(1) G01 B10. F100;
(2) T51;
(3) G00 B20.;
(4) T52;
(5) B0.;
(6) T50;
G100;
:
:
M**;
```

Where the offset of T51 is 10.0 and the offset of T52 is 5.0

19.6 ANGULAR AXIS CONTROL / ARBITRARY ANGULAR AXIS CONTROL

When the angular axis makes an angle other than 90° with the perpendicular axis, the angular axis control function controls the distance traveled along each axis according to the inclination angle. For the ordinary angular axis control function, the X-axis is always used as the angular axis and the Z-axis is always used as the perpendicular axis. For angular axis control B, however, arbitrary axes can be specified as the angular and perpendicular axes, by specifying parameters accordingly. A program, when created, assumes that the angular axis and perpendicular axis intersect at right angles. However, the actual distance traveled is controlled according to an inclination angle.

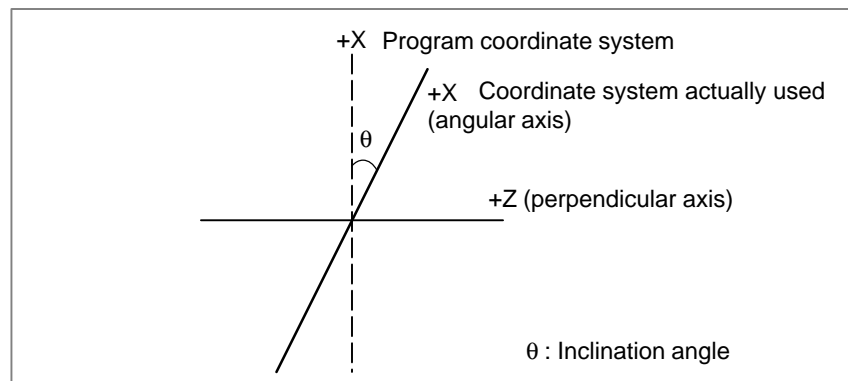

Explanations

When the angular axis is the X-axis and the perpendicular axis is the Z-axis, the amount of travel along each axis is controlled according to the formulas shown below.

The distance to be traveled along the X-axis is determined by the following formula :

$$X_a = \frac{X_p}{\cos \theta}$$

The distance traveled along the Z-axis is corrected by the inclination of the X-axis, and is determined by the following formula:

$$Z_a = Z_p - \frac{1}{2} X_p \tan \theta$$

The speed component along the X-axis of feed rate is determined by the following formula:

$$F_a = \frac{F_p}{\cos \theta}$$

X_a, Z_a, F_a: Actual distance and speed

X_p, Z_p, F_p: Programmed distance and speed

• Method of use

The angular and perpendicular axes to which angular axis control is to be applied must be specified beforehand, using parameters (No. 8211 and 8212).

Parameter AAC (No. 8200#0) enables or disables the inclined axis control function. If the function is enabled, the distance traveled along each axis is controlled according to an inclination angle (No. 8210).

Parameter AZR (No. 8200#2) enables angular axis manual reference point return only with a distance along the angular axis.

If perpendicular/angular axis control disable signal NOZAGC has been set to 1, the angular axis control function is enabled only for the angular axis. In such a case, the move command for the angular axis is converted to angular coordinates. The perpendicular axis is not affected by the move command for the angular axis.

- **Absolute and relative position display**

An absolute and a relative position are indicated in the programmed Cartesian coordinate system. Machine position display

- **Machine position display**

A machine position indication is provided in the machine coordinate system where an actual movement is taking place according to an inclination angle. However, when inch/metric conversion is performed, a position is indicated which incorporates inch/metric conversion applied to the results of inclination angle operation.

WARNING

- 1 After inclined axis control parameter setting, be sure to perform manual reference point return operation.
- 2 If bit 2 (AZR) of parameter No. 8200 has been set to 0, such that manual reference position return along the angular axis also causes movement along the perpendicular axis, once manual reference position return has been performed along the angular axis, also perform manual reference position return along the perpendicular axis.
- 3 Once the tool has been moved along the angular axis with perpendicular/angular axis control disable signal NOZAGC set to 1, manual reference position return must be performed.
- 4 Before attempting to manually move the tool along both the angular and perpendicular axes simultaneously, set perpendicular/angular axis control disable signal NOZAGC to 1.

NOTE

- 1 If an inclination angle close to 0° or $\pm 90^\circ$ is set, an error can occur. A range from $\pm 20^\circ$ to $\pm 60^\circ$ should be used.
- 2 Before a perpendicular axis reference point return check (G37) can be made, angular axis reference point return operation must be completed.
- 3 For arbitrary angular axis control, if the same axis number has been specified in both parameters No. 8211 and 8212, or if a value outside the valid data range has been specified for either parameter, the angular and perpendicular axes will be as follows:
Angular axis: First axis
Perpendicular axis: Second axis

19.7 TOOL WITHDRAWAL AND RETURN (G10.6)

To replace the tool damaged during machining or to check the status of machining, the tool can be withdrawn from a workpiece. The tool can then be advanced again to restart machining efficiently.

The tool withdrawal and return operation consists of the following four steps:

- **Retract**
The tool is retracted to a predefined position using the TOOL WITHDRAW switch.
- **Withdrawal**
The tool is moved to the tool-change position manually.
- **Return**
The tool returns to the retract position.
- **Repositioning**
The tool returns to the interrupted position.

For the tool withdrawal and return operations, see Section 4.8 in “Operation.”

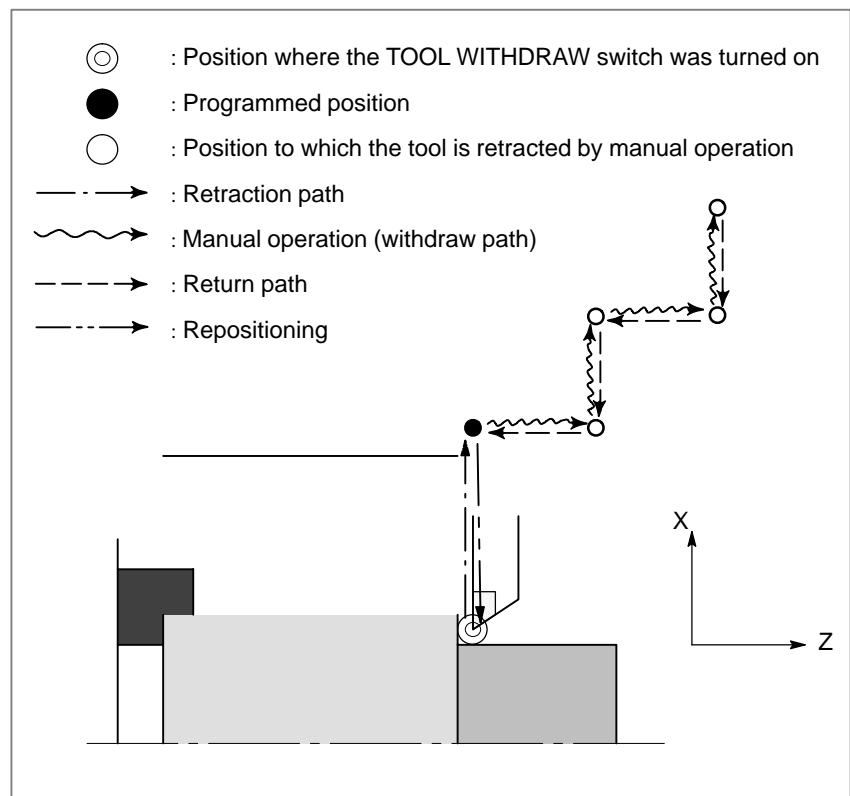

Format

Specify a retraction axis and distance in the following format:

G10.6 IP_ ;

IP_ : In incremental mode, retraction distance from the position where the retract signal is turned on
In the absolute mode, retraction distance to an absolute position

Explanations

● Retraction

When the TOOL WITHDRAW switch on the machine operator's panel is turned on during automatic operation or in the automatic operation stop or hold state, the tool is retracted the length of the programmed retraction distance. This operation is called retraction. The position at which retraction is completed is called the retraction position. Upon completion of retraction, the RETRACT POSITION LED on the machine operator's panel goes on.

When the TOOL WITHDRAW switch is turned on during execution of a block in automatic operation, execution of the block is interrupted immediately and the tool is retracted. After retraction is completed, the system enters the automatic operation hold state.

If the retraction distance and direction are not programmed, retraction is not performed. In this state, the tool can be withdrawn and returned.

When the TOOL WITHDRAW switch is turned on in the automatic operation stop or hold state, the tool is retracted, then the automatic operation stop or hold state is entered again.

When the TOOL WITHDRAW switch is turned on, the tool withdraw mode is set. When the tool withdraw mode is set, the TOOL BEING WITHDRAWN LED on the machine operator's panel goes on.

● Withdrawal

When the manual mode is set, the tool can be moved manually (manual continuous feed or manual handle feed) to replace the tool or measure a machined workpiece. This operation is called a withdrawal. The tool withdrawal path is automatically memorized by the CNC.

● Return

When the mode is returned to automatic operation mode and the TOOL RETURN switch on the machine operator's panel is turned off, the CNC automatically moves the tool to the retraction position by tracing the manually-moved tool path backwards. This operation is called a return. Upon completion of a return to the retraction position, the RETRACTIONS POSITION LED comes on.

● Repositioning

When the cycle start button is pressed while the tool is in the retraction position, the tool moves to the position where the TOOL WITHDRAW switch was turned on. This operation is called repositioning. Upon completion of repositioning, the TOOL BEING WITHDRAWN LED is turned off, indicating that the tool withdrawal mode has terminated. Operation after completion of repositioning depends on the automatic operation state when the tool withdrawal mode is set.

- (1) When the tool withdrawal mode is set during automatic operation, operation is resumed after completion of repositioning.
- (2) When the tool withdrawal mode is set when automatic operation is held or stopped, the original automatic operation hold or stop state is set after completion of repositioning. When the cycle start button is pressed again, automatic operation is resumed.

Limitations

- **offset**

If the origin, presetting, or workpiece offset is changed after retraction is specified with G10.6 in absolute mode, the change is not reflected in the retraction position. After such changes are made, the retraction position must be respecified with G10.6.

When the tool is damaged, automatic operation can be interrupted with a tool withdrawal and return operation in order to replace the tool. Note that if the offset value is changed after tool replacement, the change is ignored when automatic operation is resumed from the start point or other point in the interrupted block.
- **Machine lock, mirror image, and scaling**

When withdrawing the tool manually in the tool withdrawal mode, never use the machine lock, mirror-image, or scaling function.
- **Threading**

Tool withdrawal and return operation cannot be performed during threading.
- **Drilling canned cycle**

Tool withdrawal and return operation cannot be performed during a drilling canned cycle.
- **Reset**

Upon reset, the retraction data specified in G10.6 is cleared. Retraction data needs to be specified again.
- **Retraction command**

The tool withdrawal and return function is enabled even when the retraction command is not specified. In this case, retraction and repositioning are not performed.

WARNING

The retraction axis and retraction distance specified in G10.6 need to be changed in an appropriate block according to the figure being machined. Be very careful when specifying the retraction distance; an incorrect retraction distance may damage the workpiece, machine, or tool.

20 TWO-PATH CONTROL FUNCTION



20.1 GENERAL

- **Application to lathes with one spindle and two tool posts**

Two-path control can be used with a lathe that supports simultaneous cutting by its two independently operating tool posts.

Two-path control can be used for a lathe that machines one workpiece attached to one spindle with two tool posts simultaneously. For example, while one tool post is performing outer surface machining, the other tool post can perform inner surface machining, thus reducing machining time dramatically.

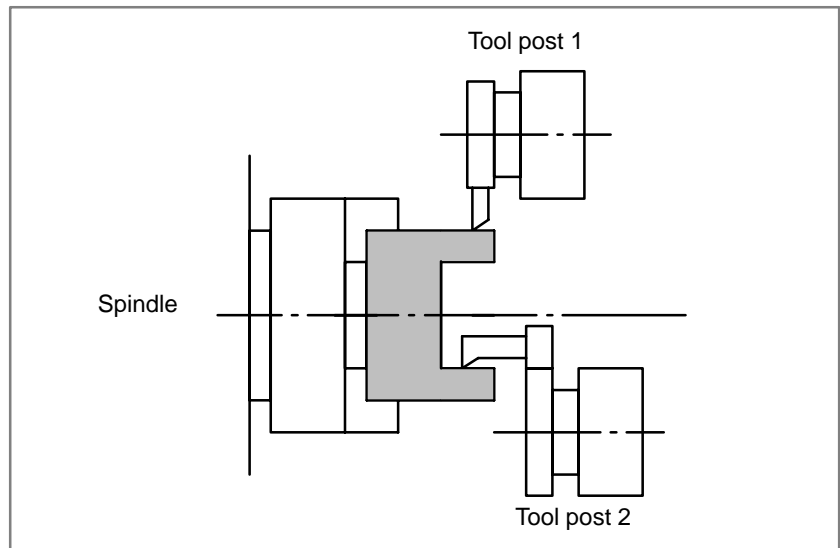

Fig. 20.1 (a) Application to lathes with one spindle and tow tool posts

- **Application to lathes with two spindles and two tool posts**

Two-path control can be used for a lathe that machines a workpiece attached to each of two spindles with two tool posts simultaneously. In this case, each tool post operates independently of each other as if two lathes were used, thus improving productivity.

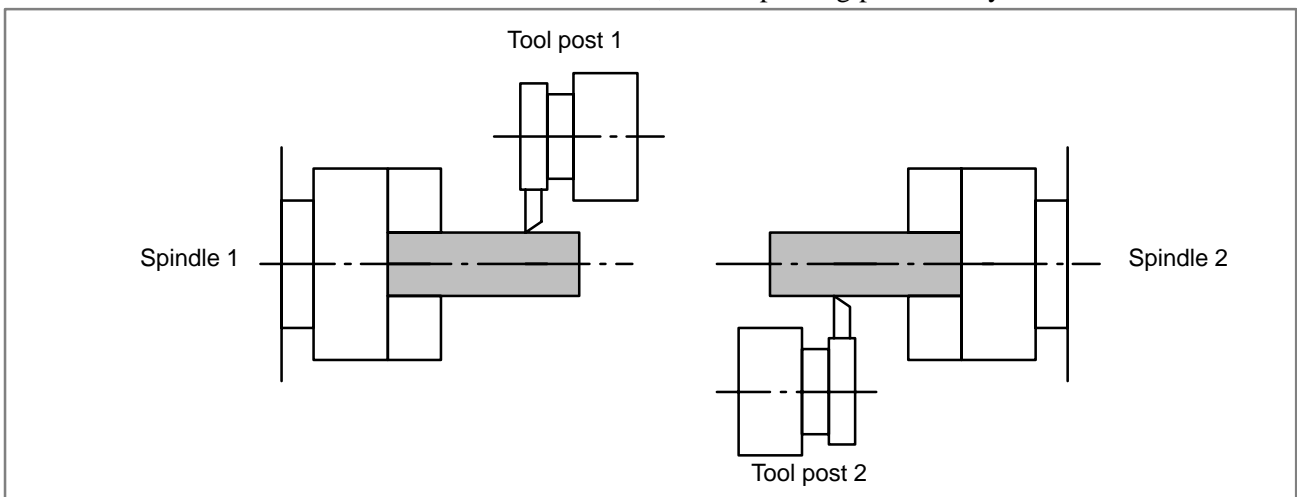

Fig. 20.1 (b) Application to lathes with two spindles and two tool posts

- **Controlling two tool posts independently at the same time**

The operations of two tool posts are programmed independently of each other, and each program is stored in program memory for each tool post. When automatic operation is to be performed, each tool post is activated after selecting a program for machining with tool post 1 and a program for machining with tool post 2 from the programs stored in program memory for each tool post. Then the programs selected for the tool posts are executed independently at the same time. When tool post 1 and tool post 2 need to wait for each other during machining, the waiting function is available (Section 20.2)

Just one MDI is provided for the two tool posts. Before operation and display on the MDI, the tool post selection signal is used to switch between the two tool posts.

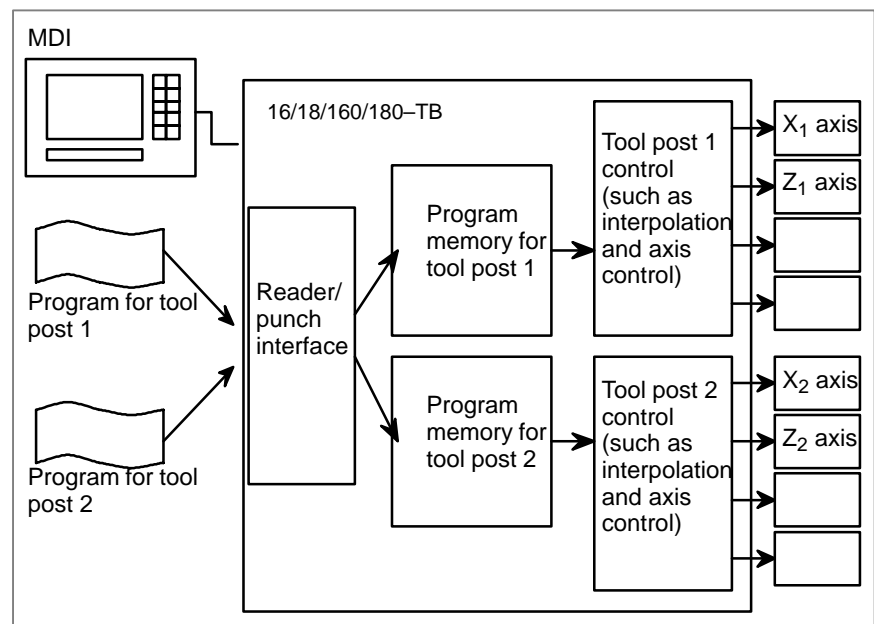

Fig. 20.1 (c) Controlling two tool posts independently at the same time

NOTE

Simultaneous operation of the two tool posts or the operation of only a single tool post can be selected by pressing a key on the machine operator's panel. For details, refer to the manual supplied by the machine tool builder.

20.2 WAITING FOR TOOL POSTS

Explanations

Control based on M codes is used to cause one tool post to wait for the other during machining. By specifying an M code in a machining program for each tool post, the two tool posts can wait for each other at a specified block. When an M code for waiting is specified in a block for one tool post during automatic operation, the other tool post waits for the same M code to be specified before starting the execution of the next block. This function is called the tool post waiting function. A range of M codes used as M codes for waiting is to be set in the parameters (Nos. 8110 and 8111) before hand.

Example

M100 to M103 are used as M codes for waiting.

Parameter setting: No. 8110= 100 (Minimum M code for waiting: M100)

No. 8111= 103 (Maximum M code for waiting: M103)

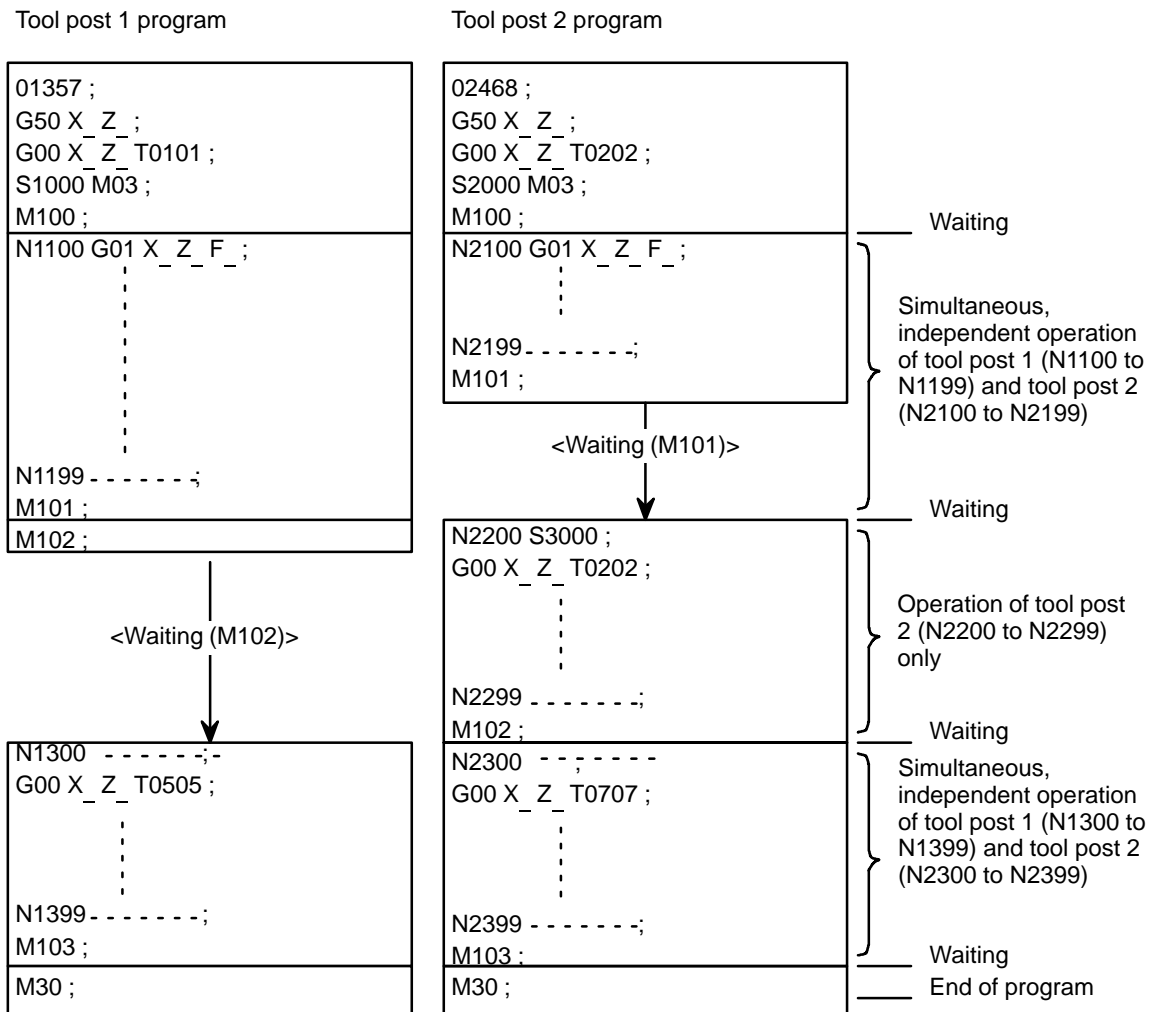

NOTE

- 1 An M code for waiting must always be specified in a single block.
- 2 If one tool post is waiting because of an M code for waiting specified, and a different M code for waiting is specified with the other tool post, an P/S alarm (No. 160) is raised. In this case, both tool posts stop operation.
- 3 PMC-CNC interface
Unlike other M codes, the M code for waiting is not output to the PMC.
- 4 Operation of a single tool post
If the operation of a single tool post is required, the M code for waiting need not be deleted. By using the NOWT signal to specify that waiting be ignored (G0063, #1), the M code for waiting in a machining program can be ignored. For details, refer to the manual supplied by the machine tool builder.

20.3 TOOL POST INTERFACE CHECK

20.3.1 General

When two tool posts machine the same workpiece simultaneously, the tool posts can approach each other very closely. If the two tool posts interfere with each other due to a program error or any other setting error, a serious damage such as a tool or machine destruction can occur. The function “tool post interference check” is available which can decelerate and stop the two tool posts before the tool posts interfere with each other due to an incorrect command.

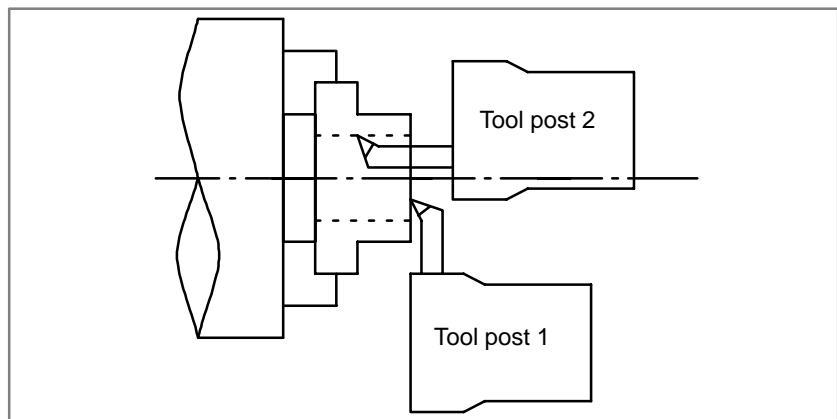

The contours of the two tool posts are checked to determine whether or not an interference occurs.

20.3.2 Data Setting for the Tool Post Interference Check Function

To make a tool post interference check, data including the relationships between the two tool posts and interference forbidden areas (that is, tool shapes) needs to be set. The method of such data setting is described below.

With the tool post interference check function, whether or not the two tool posts interfere with each other is determined by checking if the interference forbidden areas (based on the interference forbidden areas of the currently selected tools) of the tool posts overlap each other after the movement of the tool posts.

Explanations

- **Position setting for reference points of two tool posts**

When reference point return operation is completed with all axes (X1, Z1, X2, Z2), the reference point of tool post 1 is set at the origin of the ZX plane coordinate system. At this time, the position of the reference point of tool post 2 is set in a parameter. The next item describes the reference points.

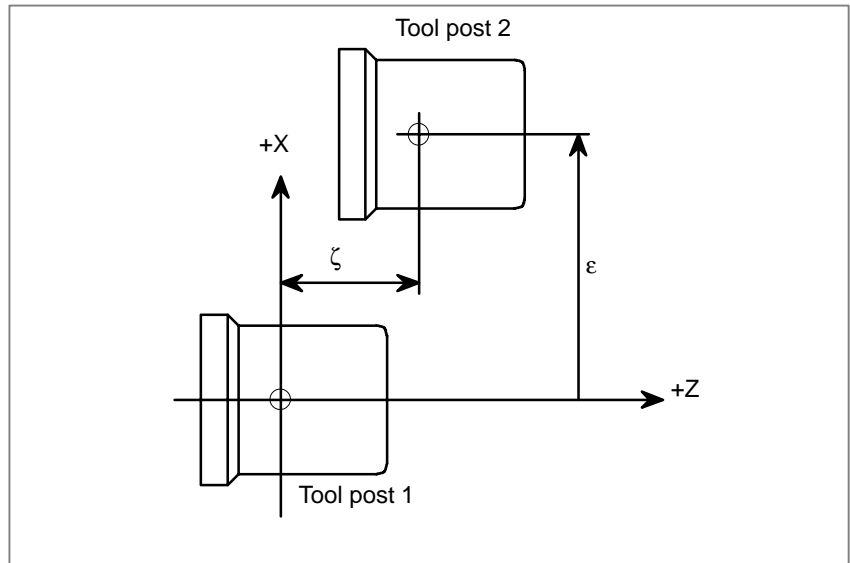

In the ZX plane coordinate system at the origin of which the reference point of tool post 1 is set, set the X coordinate (ϵ) of the reference point of tool post 2 in parameter No. 8151, and its Z coordinate (ζ) in parameter No.8152.

The unit of setting is the least command increment. For an axis subject to diameter specification, a diameter value is to be specified.

Measure (ϵ) and (ζ) when reference point return operation is completed with the four axes ($X1, Z1, X2, Z2$). When the relative coordinate parameters (Nos. 8151 and 8152) of the two tool posts are to be updated, reference point return operation must always be completed with the four axes beforehand. Otherwise, the internally memorized relational positions of the tool posts are not updated to new parameter values.

● **Set the relationship
between the coordinate
systems of the two tool
posts in parameter
No.8140**

	#7	#6	#5	#4	#3	#2	#1	#0
8140							TY1	TY0

TY0, TY1: Set the relationship between the coordinate systems of the two tool posts, with tool post 1 used as the reference.

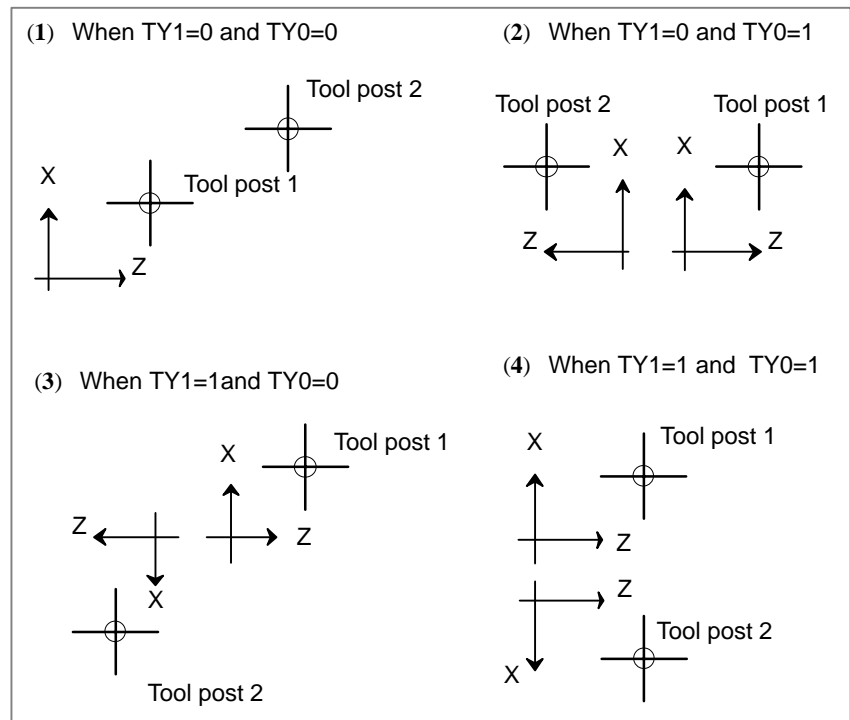

● **Setting of interference forbidden area**

An interference forbidden area is set using a combination of two rectangular areas. Some examples are shown below. The dashed lines indicate interference forbidden areas.

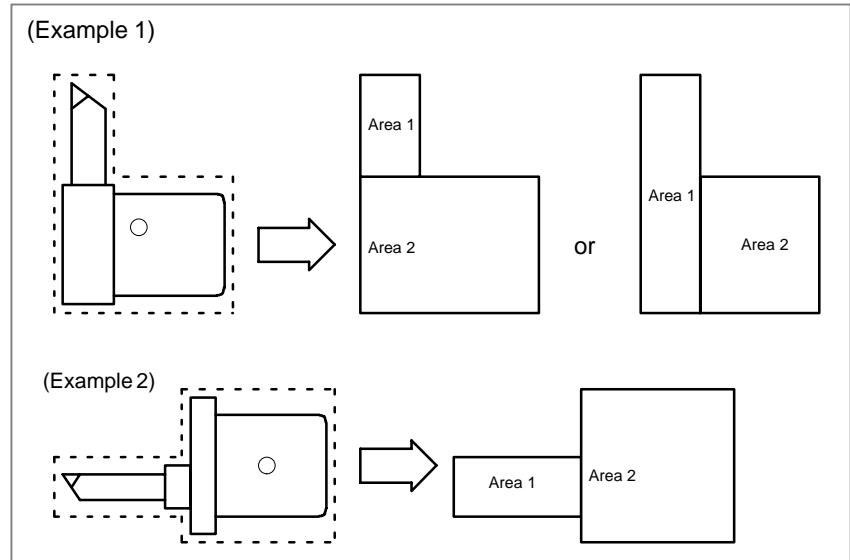

The coordinates of the upper and lower ends (points A and B shown below) of each of two rectangles are set, with the reference position of the tool post set as the origin.

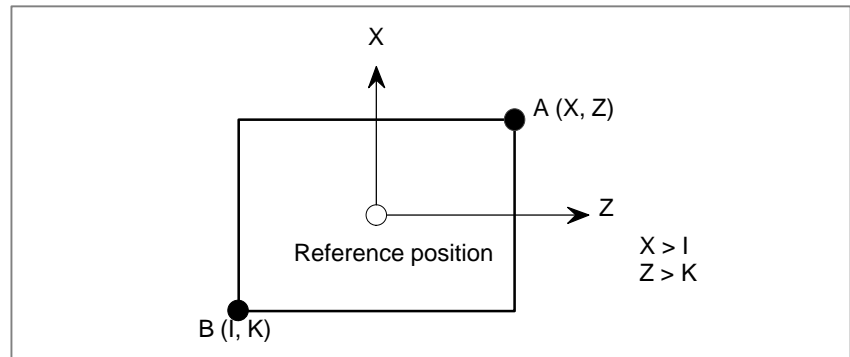

See Section 20.3.3 for information about the coordinate setting procedure.

20.3.3 Setting and Display of Interference Forbidden Areas for Tool Post Interference Checking

Explanations

Display and set tool shape data (interference forbidden areas) according to the procedure below.

- (1) Press function  key.
- (2) Press the chapter selection soft key **[TOOLFM]**.
- (3) With the tool post selection signal, select a tool post for which interference forbidden areas for tool post interference checking are to be displayed and set.
- (4) Display the screen including a tool number for which data is to be set.
Method 1: Select the screen by using the page keys and cursor keys.
Method 2: Enter a desired tool number, then press the soft key **[NO.SRH]**

```

TOOL FORM DATA                                O0001  N00001
OFFSET NO. = 01
  AREA1                                       AREA 2
  X =    20.000                               X =    40.000
  Z =    70.000                               Z =    70.000
  I =   -10.000                               I =    20.000
  K =   -50.000                               K =    30.000
OFFSET NO = 02
  AREA1                                       AREA 2
  X =    80.000                               X =  -100.000
  Z =   170.000                               Z =   -60.000
  I =  -100.000                               I =  -140.000
  K =  -120.000                               K =  -120.000

> _
MEM ***** ** 12 : 02 : 08 HEAD1
[ NO.SRH ] [ ] [ ] [ +INPUT ] [ INPUT ]
    
```

- (5) Move the cursor to a data item to be set, with the cursor move keys.
(When data for point A is to be set, move the cursor to X and Z.
When data for point B is to be set, move the cursor to I and K.)
- (6) With the numeric keys, enter the coordinates of point A or B.
(Fraction digits can be entered.)

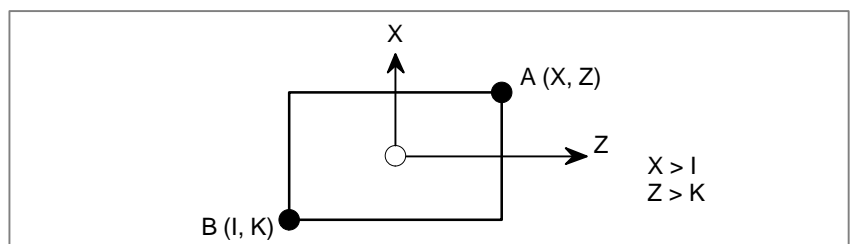

- (7) By pressing the soft key **[INPUT]**, the entered coordinates are set.
(Press the soft key **[+INPUT]** when an entered numeric value is to set after it is added to data already set.)

NOTE**1 Tool number**

The tool geometry data must be set for each tool number. The tool number here refers to the offset number. When both tool geometry offset and tool wear offset are used, the tool number corresponds to the wear offset number. To use two or more offset numbers for the same tool, the same data for the tool must be set two or more times in the tool geometry data.

2 Tool offset pairs

As for displaying and setting tool shape data (interference forbidden areas), the maximum tool number is 64.

20.3.4 Conditions for Making a Tool Post Interference Check

A tool post interference check is made when all conditions listed below are satisfied.

- (1) Parameter IFE (No. 8140#4) for enabling the tool post interference check function is set to 0.
- (2) After power is turned on, reference point return operation is completed with all axes (X1, Z1, X2, Z2). (When an absolute-position detector is used, the matching between a machine position and absolute-position detector position must be completed.)
- (3) Offset numbers other than 0 are specified using T codes for two tool posts.
- (4) When manual mode is used, parameter IFM (No. 8140#3) for enabling the tool post interference check function in manual mode is set to 1. When all conditions for making a tool post interference check are satisfied, the tool-post-interference-check-in-progress signal is output to the PMC.

WARNING

The tool post interference check function can be executed only when the number of the tool actually selected agrees with the programmed tool number.

The function cannot be executed correctly if the tool is selected by a manual operation or if no tool selection command is specified after power-on.

20.3.5 Execution of Tool Post Interference Checking

when all conditions described in Section 20.3.4 are satisfied, a tool post interference check is started. When a tool post interference check is made, an interference forbidden area is set for the two tool posts by using the tool shape data corresponding to the currently selected tool numbers. Then whether the areas interfere with each other is checked.

Explanations

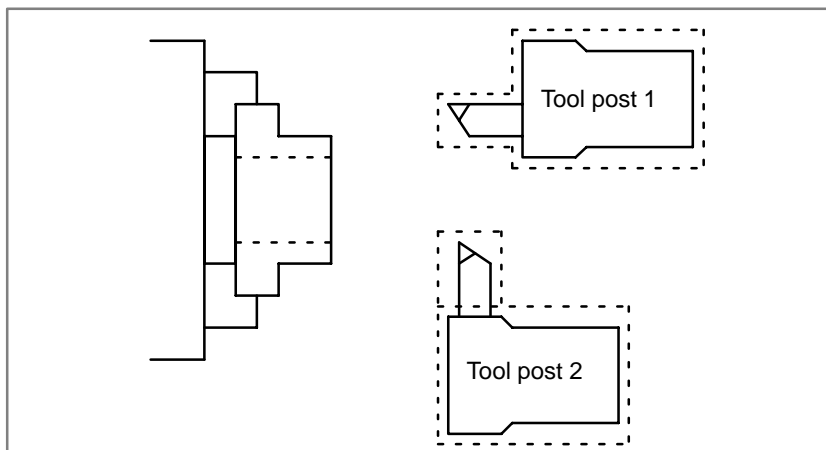

When interference forbidden areas (tool shapes) as indicated by dashed lines are set for tool posts 1 and 2 as shown above, a check is made by determining whether the two interference forbidden areas indicated by dashed lines overlap each other after the movement of the tool posts.

If the two areas interfere with each other an P/S alarm (No. 508 or No. 509) is raised; the two tool posts are decelerated and stopped.

If an interference alarm is raised, a tool post interference alarm signal is output to the PMC.

If an interference alarm is raised by the interference of the two tool posts during automatic operation, switch to manual mode to move the tool posts out of the interference state. Then release the alarm by a reset.

The interference check function can be enabled even in manual mode by setting the parameter (No. 8140#3) to 1. This allows the tool posts interfering with each other to be moved along the axes only in such directions that clear the interference. With this capability, the two tool posts interfering with each other in automatic operation cannot be manually moved by mistake further into the interference forbidden areas after the mode is switched to manual mode to clear the interference, thus providing safety.

WARNING

When an alarm is raised, the CNC system and machine system stop with some delay in time.

So an actual stop position can be closer to the other tool post beyond an interference forbidden position specified using tool shape data. So, for safety, tool shape data a little larger than the actual shape should be set. The extra distance, L, required for this purpose is calculated from a rapid traverse feedrate as follows

$$L = (\text{Rapid traverse feedrate}) \times \frac{1}{7500}$$

For example, when a rapid traverse feedrate of 15 m/min is used, L=2mm.

CAUTION

When parameters and interface forbidden areas are set to use the interference check function, be sure to check that correct interference forbidden areas are set. For this purpose, set manual mode, and cause the tool posts to interfere with each other in various directions.

20.3.6 Example of Making a Tool Post Interference Check

Explanations

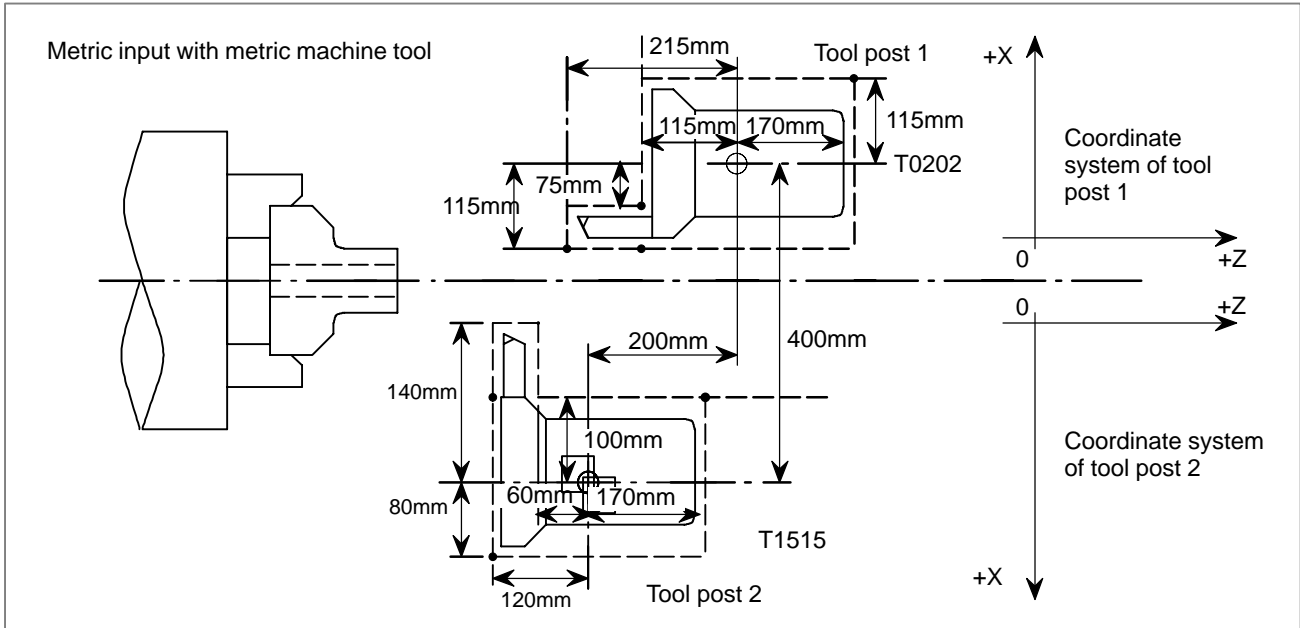

The coordinate systems shown on the right of the figure above are the ZX plane coordinate systems of tool posts 1 and 2. For clarity, the coordinate systems are shifted; actually, the origins of the coordinate systems must match the machine zero points.

Assume the machine configuration shown above. Assume also that offset number 02 is assigned to tool post 1, and offset number 15 is assigned to tool post 2.

Suppose that the figure represents the state of reference point return operation completed with all axes (X1,Z1, X2, Z2). Then set -800 mm(diameter) and -200 mm in parameter Nos. 8151 and 8152, respectively.

The positional relationship of the two tool posts matches type (4) indicated in Section 20.3.2. So set parameters TY0 and TY1 (No.8140#0, #1) as follows:

Parameter TY1 (No.8140#1)=1

Parameter TY0 (No.8140#0)=1

Then set tool shape data (interference forbidden area) for each tool post.

The figures below show the setting of data for tool number 02 assigned to tool post 1 and for tool number 15 assigned to tool post 2.

```

TOOL FORM DATA                                00001  N00001
OFFSET NO.   = 01
  AREA 1
X=  20.000
Z=  70.000
I= -10.000
K= -50.000
  AREA 2
X=  40.000
Z=  70.000
I=  20.000
K=  30.000
OFFSET NO.   = 02
  AREA 1
X= 115.000
Z= 170.000
I= -115.000
K= -115.000
  AREA 2
X= -75.000
Z= -115.000
J= -115.000
K= -215.000

>_
MEM      ****  ***  ***          12:02:08  HEAD 1
[ NO.SRH ] [      ] [      ] [ +INPUT ] [ INPUT ]

```

```

TOOL FORM DATA                                00001  N00001
OFFSET NO.   = 15
  AREA 1
X=  80.000
Z= 170.000
I= -100.000
K= -200.000
  AREA 2
X= -100.000
Z= -60.000
I= -140.000
K= -120.000
OFFSET NO.   = 16
  AREA 1
X=  0.000
Z=  0.000
I=  0.000
K=  0.000
  AREA 2
X=  0.000
Z=  0.000
I=  0.000
K=  0.000

>_
MEM      ****  ***  ***          12:02:36  HEAD 2
[ NO.SRH ] [      ] [      ] [ +INPUT ] [ INPUT ]

```

Set data for other tools similarly. A preparation for an interference check is completed when data has been set for all tools. Turn on power. Then, an interference check is started when a T code is specified with each tool post after reference point return operation is completed with all of the four axes (X1, Z1, X2, Z2).

20.4 BALANCE CUT (G68, G69)

When a thin workpiece is to be machined as shown below, a precision machining can be achieved by machining each side of the workpiece with a tool simultaneously; this function can prevent the workpiece from warpage that can result when only one side is machined at a time. When both sides are machined at the same time, the movement of one tool must be in phase with that of the other tool. Otherwise, the workpiece can vibrate, resulting in poor machining. With this function, the movement of one tool post can be easily synchronized with that of the other tool post.

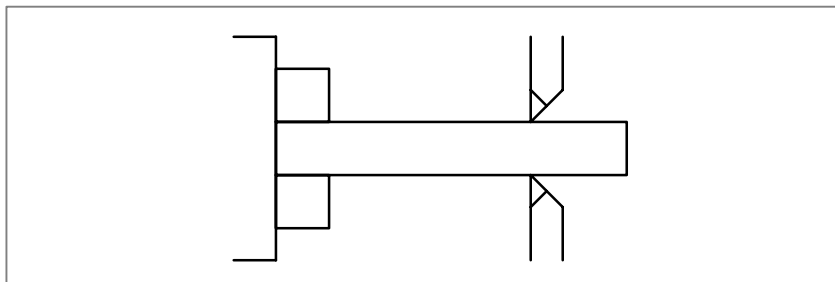

Fig. 20.4 Balance cut

Explanations

When G68 is specified in the programs for both tool post 1 and tool post 2, the pulse distribution of tool post 1 is synchronized with that of tool post 2 to start balance cutting. Thus the two tool posts can move exactly at the same time to allow balance cutting.

G code	Meaning
G68	Balance cut mode
G69	Balance cut mode cancel

In the balance cut mode, balance cutting is performed only when a move command is specified for both tool posts. Balance cutting is performed even when different axes are specified for each tool post or an offset move command is specified. G68 or G69 must be specified in a single block. (Otherwise, a P/S alarm (No. 163) is raised. When G68 or G69 is specified with one tool post, the tool post does not move until the execution for the other tool post proceeds to G68 or G69. And if cutting is specified with one tool post in the balance cut mode, the tool post does not move until the execution of or the other tool post proceeds to a cutting command.

CAUTION

Balance cut only starts cutting feed on both tool posts at the same time; it does not maintain synchronization thereafter. To synchronize all the movements of both tool posts, the setting for both tool posts, such as the travel distance and feedrate, must be the same.

Example

Tool post 1 program	Tool post 2 program	
⋮	⋮	
G68 ;	G68 ;	← Balance cut mode
G01Z100.0 ;	G01Z100.0 ;	← Balance cut
Z0 ;	Z0 ;	← Balance cut
G69 ;	G69 ;	← Balance cut mode
⋮	⋮	cancel

CAUTION

- 1 Balance cutting is not performed in dry run or machine lock state.
- 2 When rapid traverse operation is specified, balance cut processing is not performed.
- 3 A workpiece for which thread cutting has been performed in the balance cut mode cannot be subjected to thread cutting in the cancel mode. Thread cutting starts at a different position.

NOTE

- 1 Time delay before the pulse distribution of both tool posts is started is 2 msec or shorter.
- 2 In the balance cut mode, synchronization is established at the start of a move block, so movement can momentarily stop.
- 3 If feed hold operation is performed during balance cutting using both tool posts, balance cut processing is not performed at restart time, it is performed when the next move command is specified for both tool posts.
- 4 The cancel mode (G69) is set by a reset.
- 5 When the option "mirror image for double turrets" is selected, the balance cut function cannot be used.

20.5 MEMORY COMMON TO TOOL POSTS

A machine with two tool posts has different custom macro common variables and tool compensation memory areas for tool posts 1 and 2. Tool posts 1 and 2 can share the custom macro common variables and tool compensation memory areas provided certain parameters are specified accordingly.

Explanations

- **Custom macro common variables**

Tool posts 1 and 2 can share all or part of custom macro common variables #100 to #149 and #500 to #531, provided parameters 6036 and 6037 are specified accordingly. (The data for the shared variables can be written or read from either tool post.) See Section 15.1 of Part II.
- **Tool compensation memory**

Tool post 2 can reference or specify the data in the tool compensation memory area of tool post 1, provided the CMF bit (bit 5 of parameter 8100) is specified accordingly. This can be executed only when tool posts 1 and 2 have identical data for tool compensation (number of groups, number of columns, unit system, etc.).

20.6 SPINDLE CONTROL IN TWO-PATH CONTROL

The two-path control function supports two spindle interfaces. Thus, 16-TB can control a lathe that simultaneously machines a workpiece attached to one spindle with two tool posts, or can control a lathe that simultaneously machines a workpiece attached to each of two spindles with two tool posts.

The former spindle control is referred to as 1-spindle control, and the latter is referred to as 2-spindle control.

Parameter 2SP (No. 3703#0) is used to select 1-spindle control or 2-spindle control.

Explanations

• 1-spindle control

One spindle is controlled by programmed commands for tool post 1 or tool post 2. Programmed commands (Note 1) for the spindle can be specified from either tool post. However, a spindle speed output selection signal (Note 2) determines which commands from the two tool posts are valid. The spindle is controlled according to the commands from a tool post selected by the signal.

A feedback pulse signal from the position coder attached to the spindle is applied to both tool posts. Such a feedback pulse signal is used for processing such as thread cutting and feed per rotation with each tool post.

• 2-spindle control

Two spindles, spindle 1 and spindle 2 (Note 3), are controlled independently of each other according to programmed commands (Note 1) for each tool post. Usually, programmed commands for tool post 1 are used to control spindle 1, and programmed commands for tool post 2 are used to control spindle 2. Feedback pulse signals from the position coders attached to spindle 1 and spindle 2 are applied to tool post 1 and tool post 2, respectively.

The spindle speed output selection signal (Note 2) can be used to specify which spindle must be controlled by programmed commands for which tool post. In addition, a spindle feedback input selection signal (Note 2) can be used to specify which spindle must be controlled by programmed commands for which tool post. In addition, a spindle feedback input selection signal (Note 2) can be used to specify which tool post must receive a feedback signal from which spindle. Thus, tool post 1 can control spindle 2, and tool post 2 can control spindle 1.

NOTE

- 1 The programmed commands for spindles include the following.
 - S code to specify a spindle speed
 - M03 (forward spindle rotation), M04 (reverse spindle rotation)
 - Commands for constant surface speed control (G96, G97, S code to specify surface speeds, commands to specify maximum spindle speeds)
- 2 Refer to the CONNECTION MANUAL (FUNCTION) for detailed information about the spindle speed output selection signal and spindle feedback input selection signal. Control over these signals varies from one machine tool builder to another. So be sure to read the relevant manual prepared by the machine tool builder to be familiar with the commands for the spindles.
- 3 The spindle connected to spindle interface 1 (main CPU board) is defined as spindle 1, and the spindle connected to spindle interface 2 (optional board 2) is defined as spindle 2. For detail refer to CONNECTION MANUAL (FUNCTION).

20.7 SYNCHRONIZATION CONTROL AND COMPOSITE CONTROL

In 2-paths control, the synchronization control function and composite control function enable synchronization control in a single system or between two systems, composite control of two systems, and superposition control of two systems.

Explanations

- **Synchronization control**

Synchronizes movement along an axis of one system with that along an axis of the other system.

Example)

Synchronizing movement along the Z1 and Z2 axes

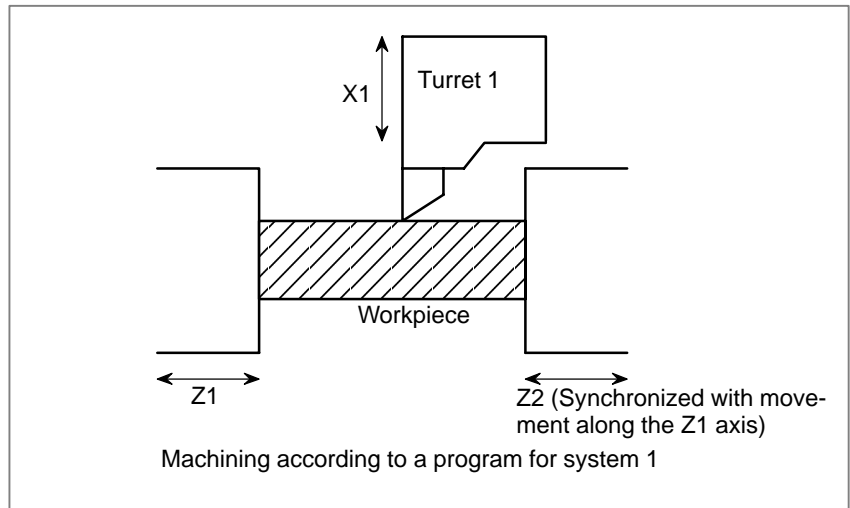

Synchronizes movement along an axis of one system with that along another axis of the same system.

Example)

Synchronizing movement along the Z1 and B1 axes

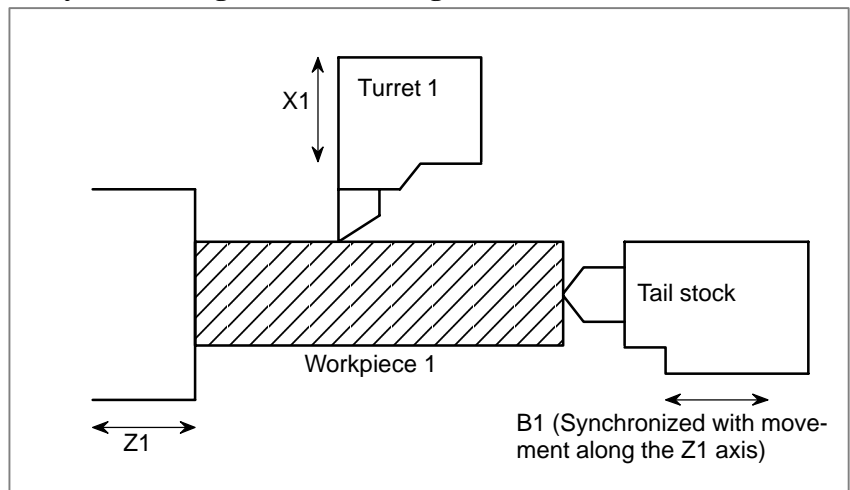

• **Composite control**

Exchanges the move commands for different axes of different systems.

Example)

Exchanging the commands for the X1 and X2 axes

→ Upon the execution of a command programmed for system 1, movement is performed along the X2 and Z1 axes.

Upon the execution of a command programmed for system 2, movement is performed along the X1 and Z2 axes.

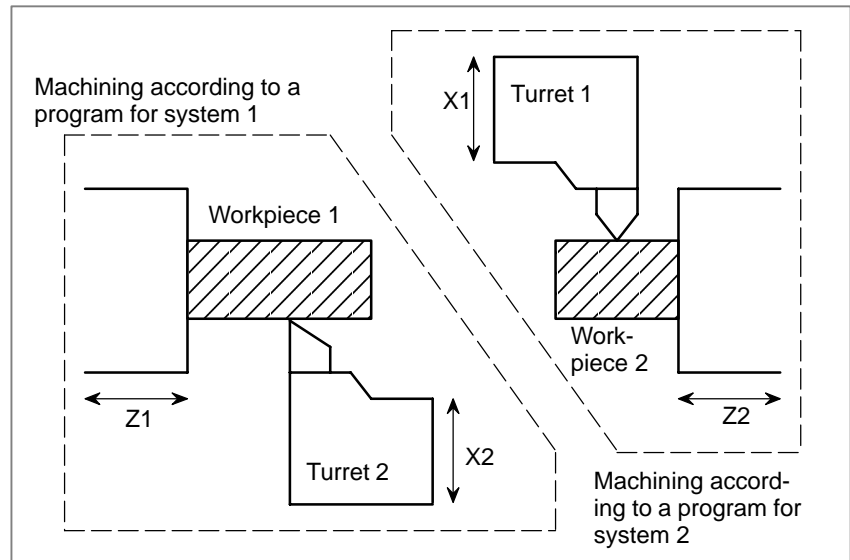

• **Superposition control**

Provides a move command of an axis for a different axis in another system.

Example)

Providing the Z2 axis with a move command specified for the Z1 axis

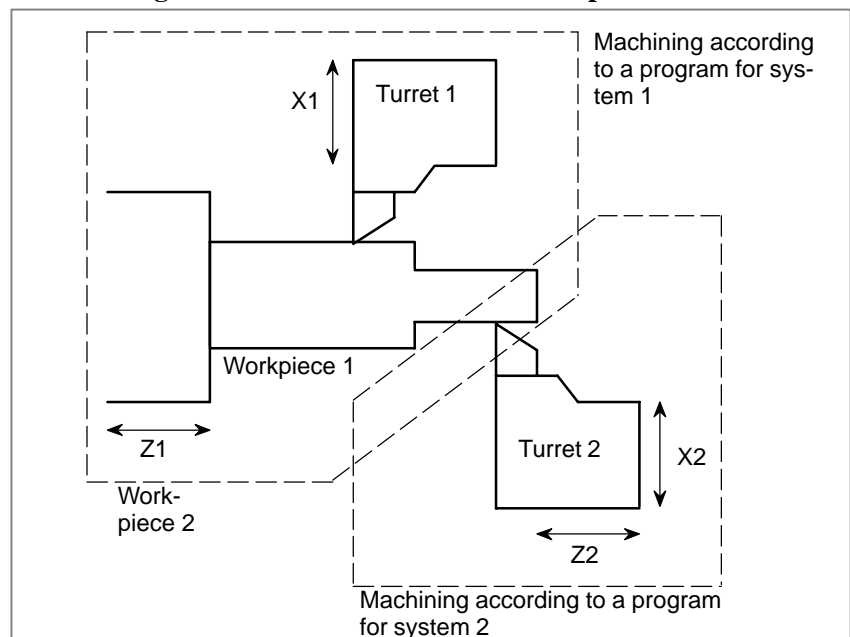

NOTE

The method used to specify synchronization or composite control varies with the machine tool builder. For details, refer to the manual supplied by the machine tool builder.

20.8 COPYING A PROGRAM BETWEEN TWO PATHS

In a CNC supporting two-path control, specified machining programs can be copied between the two paths by setting bit 0 (PCP) of parameter No. 3206 to 1. A copy operation can be performed by specifying either a single program or a range. For information about operations, see Section 9.10 in Part III.

Explanations

- **Single-program copy**

Copy source number: 0001
Copy destination number: Not set

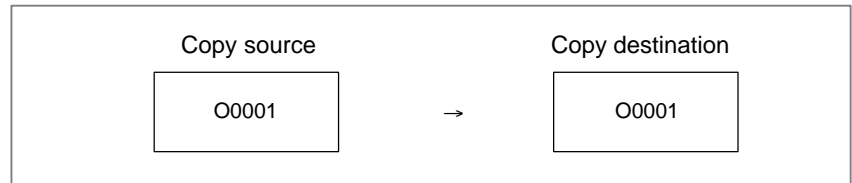

Copy source number: 0001
Copy destination 0010

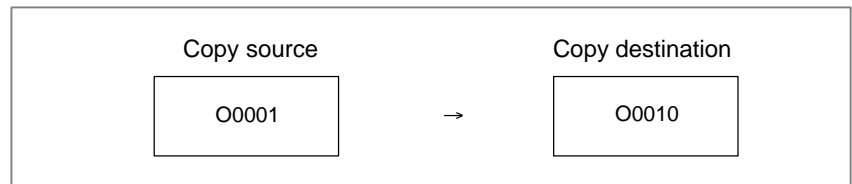

- **Specified-range copy**

Copy source number: 0001 to 0100
Copy destination number: Not set

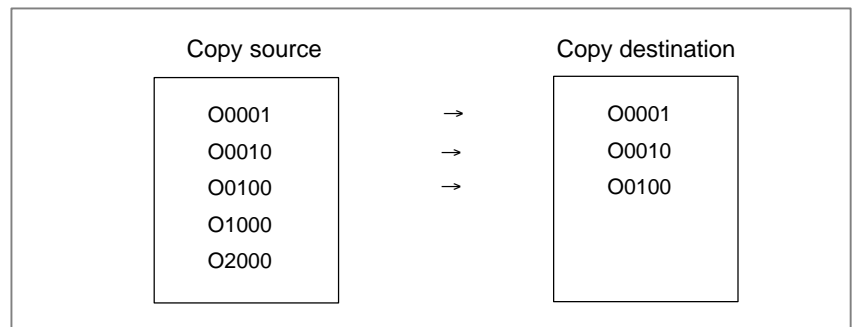

Copy source number: 0001 to 0100
Copy destination 1000

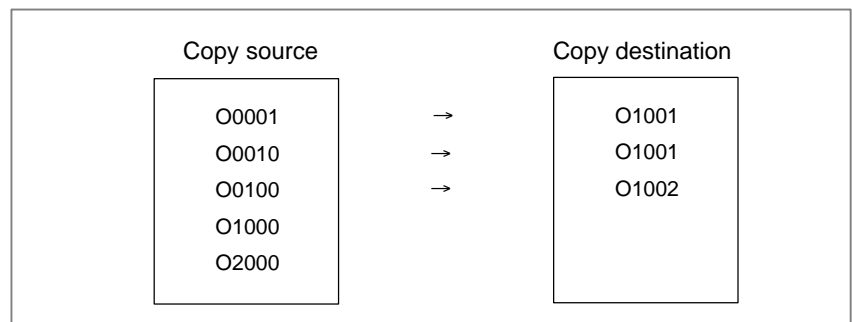

21

PATTERN DATA INPUT FUNCTION

This function enables users to perform programming simply by extracting numeric data (pattern data) from a drawing and specifying the numerical values from the MDI panel.

This eliminates the need for programming using an existing NC language.

With the aid of this function, a machine tool builder can prepare the program of a hole machining cycle (such as a boring cycle or tapping cycle) using the custom macro function, and can store it into the program memory.

This cycle is assigned pattern names, such as BOR1, TAP3, and DRL2.

An operator can select a pattern from the menu of pattern names displayed on the screen.

Data (pattern data) which is to be specified by the operator should be created in advance with variables in a drilling cycle.

The operator can identify these variables using names such as DEPTH, RETURN RELIEF, FEED, MATERIAL or other pattern data names. The operator assigns values (pattern data) to these names.

21.1 DISPLAYING THE PATTERN MENU

Pressing the  key and  **[MENU]** is displayed on the following pattern menu screen.

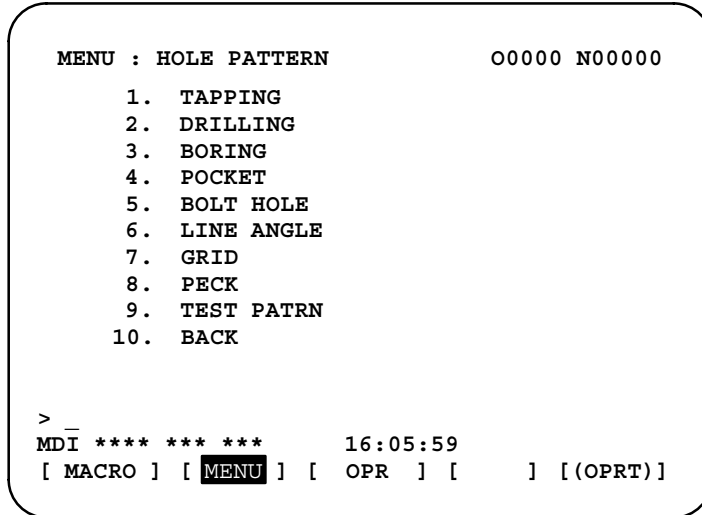

HOLE PATTERN :

This is the menu title. An arbitrary character string consisting of up to 12 characters can be specified.

BOLT HOLE :

This is the pattern name. An arbitrary character string consisting of up to 10 characters can be specified, including katakana.

The machine tool builder should specify the character strings for the menu title and pattern name using the custom macro, and load the character strings into program memory as a subprogram of program No. 9500.

● **Macro commands
specifying the menu
title**

Menu title : $C_1 C_2 C_3 C_4 C_5 C_6 C_7 C_8 C_9 C_{10} C_{11} C_{12}$
 C_1, C_2, \dots, C_{12} : Characters in the menu title (12 characters)

Macro instruction

G65 H90 P_p Q_q R_r I_i J_j K_k:

H90: Specifies the menu title

p : Assume a1 and a2 to be the codes of characters C1 and C2. Then,

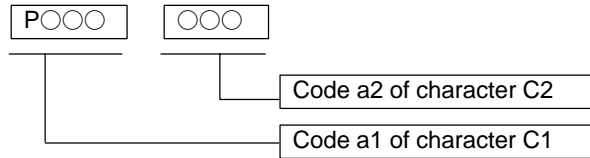

q : Assume a3 and a4 to be the codes of characters C3 and C4. Then,
 $q = a_3 10^3 + a_4$

r : Assume a5 and a6 to be the codes of characters C5 and C6. Then,
 $r = a_5 10^3 + a_6$

i : Assume a7 and a8 to be the codes of characters C7 and C8. Then,
 $i = a_7 10^3 + a_8$

j : Assume a9 and a10 to be the codes of characters C9 and C10. Then,
 $j = a_9 10^3 + a_{10}$

k : Assume a11 and a12 to be the codes of characters C11 and C12. Then,
 $k = a_{11} 10^3 + a_{12}$

Example)

If the title of the menu is “HOLE PATTERN” then the macro instruction is as follows:

G65 H90 $\frac{P072079}{HO}$ $\frac{Q076069}{LE}$ $\frac{R032080}{\square P}$
 $\frac{I065084}{AT}$ $\frac{J084069}{TE}$ $\frac{K082078}{RN}$;

For codes corresponding to these characters, refer to the table in II-21.3.

● **Macro instruction describing the pattern name**

Pattern name: C₁ C₂ C₃ C₄ C₅ C₆ C₇ C₈ C₉C₁₀
 C₁, C₂, ,C₁₀: Characters in the pattern name (10 characters)
 Macro instruction
 G65 H91 P_n Q_q R_r I_i J_j K_k ;
 H91: Specifies the menu title
 n : Specifies the menu No. of the pattern name
 n=1 to 10
 q : Assume a₁ and a₂ to be the codes of characters C₁ and C₂. Then,
 $q = a_1 \times 10^3 + a_2$
 r : Assume a₃ and a₄ to be the codes of characters C₃ and C₄. Then,
 $r = a_3 \times 10^3 + a_4$
 i : Assume a₅ and a₆ to be the codes of characters C₅ and C₆. Then,
 $i = a_5 \times 10^3 + a_6$
 j : Assume a₇ and a₈ to be the codes of characters C₇ and C₈. Then,
 $j = a_7 \times 10^3 + a_8$
 k : Assume a₉ and a₁₀ to be the codes of characters C₉ and C₁₀. Then,
 $k = a_9 \times 10^3 + a_{10}$

Example)

If the pattern name of menu No. 1 is “BOLT HOLE” then the macro instruction is as follows.

G65 H91 P1 Q066079 R076084 I032072 J079076 K069032 ;
 BO LT □H OL E□

● **Pattern No. selection**

To select a pattern from the pattern menu screen, enter the corresponding pattern No. The following is an example.



The selected pattern No. is assigned to system variable #5900. The custom macro of the selected pattern can be started by starting a fixed program (external program No. search) with an external signal then referring to the system variable #5900 in the program.

NOTE
 If each characters of P, Q, R, I, J, and K are not specified in a macro instruction, two spaces are assigned to each omitted character.

Example

Custom macros for the menu title and hole pattern names.

```

MENU : HOLE PATTERN           O0000 N00000
  1.  TAPPING
  2.  DRILLING
  3.  BORING
  4.  POCKET
  5.  BOLT HOLE
  6.  LINE ANGLE
  7.  GRID
  8.  PECK
  9.  TEST PATRN
 10.  BACK

> _
MDI **** * 16:05:59
[ MACRO ] [ MENU ] [ OPR ] [ ] [ (OPRT) ]
    
```

```

O9500 ;
N1G65 H90 P072 079 Q076 069 R032 080 I 065 084 J 084 069 K082 078 ; HOLE PATTERN
N2G65 H91 P1 Q066 079 R076 084 I 032 072 J 079 076 K069 032 ; 1.BOLT HOLE
N3G65 H91 P2 Q071 082 R073 068 ; 2.GRID
N4G65 H91 P3 Q076 073 R078 069 I 032 065 J 078071 K076069 ; 3.LINE ANGLE
N5G65 H91 P4 Q084 065 R080 080 I 073 078 J 071 032 ; 4.TAPPING
N6G65 H91 P5 Q068 082 R073 076 I 076 073 J 078 071 ; 5.DRILLING
N7G65 H91 P6 Q066079 R082073 I 078 071 ; 6.BORING
N8G65 H91 P7 Q080 079 R067 075 I 069 084 ; 7.POCKET
N9G65 H91 P8 Q080069 R067075 ; 8.PECK
N10G65 H91 P9 Q084 069 R083 084 I032 080 J065 084 K082 078 ; 9.TEST PATRN
N11G65 H91 P10 Q066 065 R067 0750 ; 10.BACK
N12M99 ;
    
```

21.2 PATTERN DATA DISPLAY

When a pattern menu is selected, the necessary pattern data is displayed.

```

VAR. : BOLT HOLE                                O0001 N00000
NO.  NAME          DATA  COMMENT
500  TOOL          0.000
501  STANDARD X    0.000  *BOLT HOLE
502  STANDARD Y    0.000  CIRCLE*
503  RADIUS        0.000  SET PATTERN
504  S. ANGL       0.000  DATA TO VAR.
505  HOLES NO      0.000  NO.500-505.
506                                0.000
507                                0.000

ACTUAL POSITION (RELATIVE)
X    0.000      Y    0.000
Z    0.000

> _
MDI **** * 16:05:59
[ MACRO ] [ MENU ] [ OPR ] [ ] [(OPRT)]

```

BOLT HOLE :

This is the pattern data title. A character string consisting of up to 12 characters can be set.

TOOL :

This is the variable name. A character string consisting of up to 10 characters can be set.

***BOLT HOLE CIRCLE* :**

This is a comment statement. A character string can be displayed consisting of up to 8 lines, 12 characters per line.

(It is permissible to use katakana in a character string or line.)

The machine tool builder should program the character strings of pattern data title, pattern name, and variable name using the custom macro, and load them into the program memory as a subprogram whose No. is 9500 plus the pattern No. (O9501 to O9510).

● **Macro instruction specifying the pattern data title (the menu title)**

Menu title : $C_1 C_2 C_3 C_4 C_5 C_6 C_7 C_8 C_9 C_{10} C_{11} C_{12}$
 C_1, C_2, \dots, C_{12} : Characters in the menu title (12 characters)
 Macro instruction
 $G65 H92 P_n Q_q R_r I_i J_j K_k ;$
 $H92$: Specifies the pattern name
 p : Assume a_1 and a_2 to be the codes of characters C_1 and C_2 . Then,
 $p = a_1 \cdot 10^3 + a_2$
 See 17.3 for character codes.
 q : Assume a_3 and a_4 to be the codes of characters C_3 and C_4 . Then,
 $q = a_3 \cdot 10^3 + a_4$
 r : Assume a_5 and a_6 to be the codes of characters C_5 and C_6 . Then,
 $r = a_5 \cdot 10^3 + a_6$
 i : Assume a_7 and a_8 to be the codes of characters C_7 and C_8 . Then,
 $i = a_7 \cdot 10^3 + a_8$
 j : Assume a_9 and a_{10} to be the codes of characters C_9 and C_{10} . Then,
 $j = a_9 \cdot 10^3 + a_{10}$
 k : Assume a_{11} and a_{12} to be the codes of characters C_{11} and C_{12} . Then,
 $k = a_{11} \cdot 10^3 + a_{12}$

Example)

Assume that the pattern data title is “BOLT HOLE.” The macro instruction is given as follows:

$G65 H92 \frac{P066079}{BO} \frac{Q076084}{LT} \frac{R032072}{\sqcup H} \frac{I079076}{OL} \frac{J069032}{E} ;$

● **Macro instruction specifying the variable name**

Variable name : $C_1 C_2 C_3 C_4 C_5 C_6 C_7 C_8 C_9 C_{10}$
 C_1, C_2, \dots, C_{10} : Characters in the variable name (10 characters)
 Macro instruction
 $G65 H93 P_n Q_q R_r I_i J_j K_k ;$
 $H93$: Specifies the variable name
 n : Specifies the menu No. of the variable name
 $n = 1$ to 10
 q : Assume a_1 and a_2 to be the codes of characters C_1 and C_2 . Then,
 $q = a_1 \cdot 10^3 + a_2$
 r : Assume a_3 and a_4 to be the codes of characters C_3 and C_4 . Then,
 $r = a_3 \cdot 10^3 + a_4$
 i : Assume a_5 and a_6 to be the codes of characters C_5 and C_6 . Then,
 $i = a_5 \cdot 10^3 + a_6$
 j : Assume a_7 and a_8 to be the codes of characters C_7 and C_8 . Then,
 $j = a_7 \cdot 10^3 + a_8$
 k : Assume a_9 and a_{10} to be the codes of characters C_9 and C_{10} . Then,
 $k = a_9 \cdot 10^3 + a_{10}$

Example)

Assume that the variable name of the variable No. 503 is “RADIUS.” The macro instruction is given as follows:

$G65 H93 P503 \frac{Q082065}{RA} \frac{R068073}{DI} \frac{I085083}{US} ;$

- **Macro instruction to describe a comment**

One comment line: $C_1 C_2 C_3 C_4 C_5 C_6 C_7 C_8 C_9 C_{10} C_{11} C_{12}$

C_1, C_2, \dots, C_{12} : Character string in one comment line (12 characters)

Macro instruction

G65 H94 P_n Q_q R_r I_i J_j K_k ;

H94 : Specifies the comment

p : Assume a_1 and a_2 to be the codes of characters C_1 and C_2 . Then,

$$p = a_1 \cdot 10^3 + a_2$$

See 17.7 for character codes.

q : Assume a_3 and a_4 to be the codes of characters C_3 and C_4 . Then,

$$q = a_3 \cdot 10^3 + a_4$$

r : Assume a_5 and a_6 to be the codes of characters C_5 and C_6 . Then,

$$r = a_5 \cdot 10^3 + a_6$$

i : Assume a_7 and a_8 to be the codes of characters C_7 and C_8 . Then,

$$i = a_7 \cdot 10^3 + a_8$$

j : Assume a_9 and a_{10} to be the codes of characters C_9 and C_{10} . Then,

$$j = a_9 \cdot 10^3 + a_{10}$$

k : Assume a_{11} and a_{12} to be the codes of characters C_{11} and C_{12} . Then,

$$k = a_{11} \cdot 10^3 + a_{12}$$

A comment can be displayed in up to eight lines. The comment consists of the first line to the eighth line in the programmed sequence of G65 H94 for each line.

Example)

Assume that the comment is "BOLT HOLE." The macro instruction is given as follows:

G65 H94 P042066 Q079076 R084032 I072079 J076069;
 *B OL T □ HO LE

Examples

Macro instruction to describe a parameter title , the variable name, and a comment.

```

VAR. : BOLT HOLE                                O0001 N00000
NO.  NAME          DATA  COMMENT
500  TOOL          0.000
501  STANDARD X    0.000  *BOLT HOLE
502  STANDARD Y    0.000  CIRCLE*
503  RADIUS        0.000  SET PATTERN
504  S. ANGL      0.000  DATA TO VAR.
505  HOLES NO     0.000  NO.500-505.
506                          0.000
507                          0.000

ACTUAL POSITION (RELATIVE)
X    0.000      Y    0.000
Z    0.000

> _
MDI **** * * * *      16:05:59
[ MACRO ] [ MENU ] [ OPR ] [   ] [(OPRT)]
    
```

```

O9501 ;
N1G65 H92 P066 079 Q076 084 R032 072 I 079 076 J069 032 ;      VAR : BOLT HOLE
N2G65 H93 P500 Q084 079 R079076 ;                              #500 TOOL
N3G65 H93 P501 Q075 073 R074 085 I078 032 J088 032 ;          #501 KIJUN X
N4G65 H93 P502 Q075 073 R074 085 I 078 032 J089 032 ;          #502 KIJUN Y
N5G65 H93 P503 Q082 065 R068 073 I 085 083 ;                  #503 RADIUS
N6G65 H93 P504 Q083 046 R032 065 I 078 071 J 076 032 ;        #504 S.ANGL
N7G65 H93 P505 Q072 079 R076 069 I 083 032 J078 079 K046 032 ; #505 HOLES NO
N8G65 H94 ;                                                    Comment
N9G65 H94 P042 066 Q079 076 R084 032 I072 079 J076 069 ;      *BOLT HOLE
N10G65 H94 R032 067 I073 082 J067 076 K069 042 ;              CIRCLE*
N11G65 H94 P083 069 Q084 032 080 065 I084 084 J069 082 K078 032 ; SET PATTERN
N12G65 H94 P068 065 Q084 065 R032 084 I079 032 J086 065 K082046 ; DATA NO VAR.
N13G65 H94 P078 079 Q046 053 R048 048 I045 053 J048 053 K046 032 ; No.500-505
N14M99 ;
    
```

21.3 CHARACTERS AND CODES TO BE USED FOR THE PATTERN DATA INPUT FUNCTION

Table.21.3 (a) Characters and codes to be used for the pattern data input function

Character	Code	Comment	Character	Code	Comment
A	065		6	054	
B	066		7	055	
C	067		8	056	
D	068		9	057	
E	069			032	Space
F	070		!	033	Exclamation mark
G	071		"	034	Quotation mark
H	072		#	035	Hash sign
I	073		\$	036	Dollar sign
J	074		%	037	Percent
K	075		&	038	Ampersand
L	076		'	039	Apostrophe
M	077		(040	Left parenthesis
N	078)	041	Right parenthesis
O	079		*	042	Asterisk
P	080		+	043	Plus sign
Q	081		,	044	Comma
R	082		-	045	Minus sign
S	083		.	046	Period
T	084		/	047	Slash
U	085		:	058	Colon
V	086		;	059	Semicolon
W	087		<	060	Left angle bracket
X	088		=	061	Equal sign
Y	089		>	062	Right angle bracket
Z	090		?	063	Question mark
0	048		@	064	HAT"mark
1	049		[091	Left square bracket
2	050		^	092	
3	051		¥	093	Yen sign
4	052]	094	Right square bracket
5	053		_	095	Underscore

NOTE

Right and left parentheses cannot be used.

Table 21.3 (b) Numbers of subprograms employed in the pattern data input function

Subprogram No.	Function
O9500	Specifies character strings displayed on the pattern data menu.
O9501	Specifies a character string of the pattern data corresponding to pattern No.1
O9502	Specifies a character string of the pattern data corresponding to pattern No.2
O9503	Specifies a character string of the pattern data corresponding to pattern No.3
O9504	Specifies a character string of the pattern data corresponding to pattern No.4
O9505	Specifies a character string of the pattern data corresponding to pattern No.5
O9506	Specifies a character string of the pattern data corresponding to pattern No.6
O9507	Specifies a character string of the pattern data corresponding to pattern No.7
O9508	Specifies a character string of the pattern data corresponding to pattern No.8
O9509	Specifies a character string of the pattern data corresponding to pattern No.9
O9510	Specifies a character string of the pattern data corresponding to pattern No.10

Table. 21.3 (c) Macro instructions used in the pattern data input function

G code	H code	Function
G65	H90	Specifies the menu title.
G65	H91	Specifies the pattern name.
G65	H92	Specifies the pattern data title.
G65	G93	Specifies the variable name.
G65	H94	Specifies the comment.

Table. 21.3 (d) System variables employed in the pattern data input function

System variable	Function
#5900	Pattern No. selected by user.

III. OPERATION

1

GENERAL



1.1 MANUAL OPERATION

Explanations

- **Manual reference position return (See Section III-3.1)**

The CNC machine tool has a position used to determine the machine position.

This position is called the reference position, where the tool is replaced or the coordinate are set. Ordinarily, after the power is turned on, the tool is moved to the reference position.

Manual reference position return is to move the tool to the reference position using switches and pushbuttons located on the operator's panel.

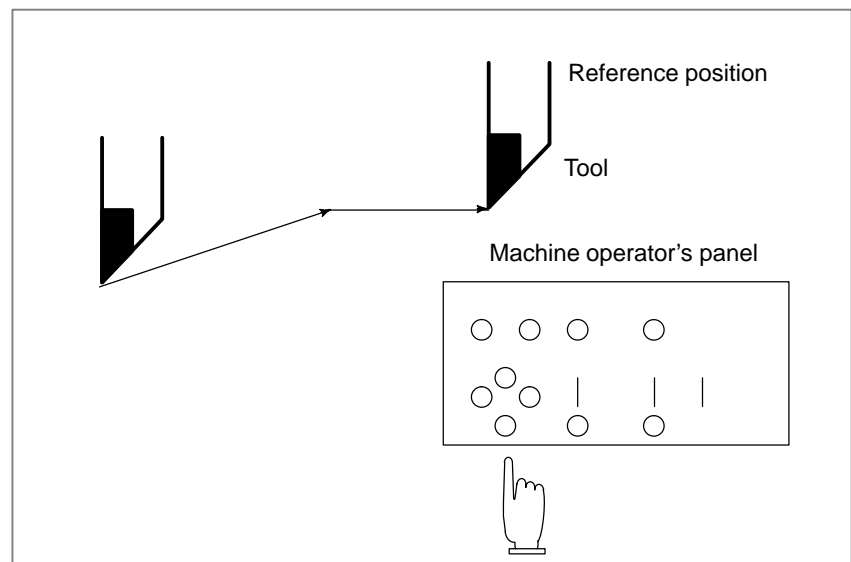

Fig. 1.1 (a) Manual reference position return

The tool can be moved to the reference position also with program commands.

This operation is called automatic reference position return (See Section II-6).

- **The tool movement by manual operation**

Using machine operator's panel switches, push buttons, or the manual handle, the tool can be moved along each axis.

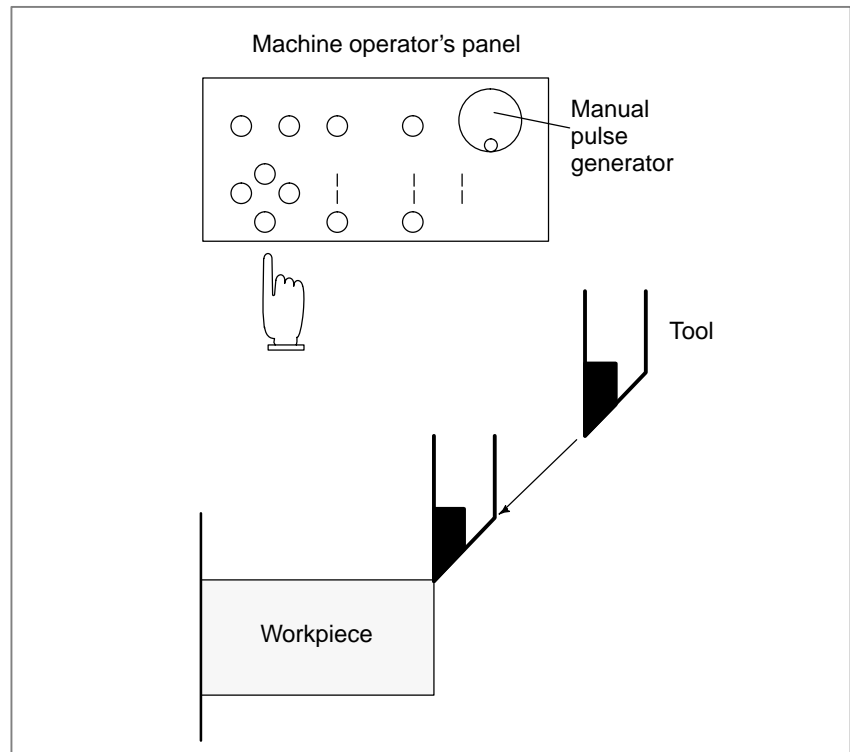

Fig. 1.1 (b) The tool movement by manual operation

The tool can be moved in the following ways:

- (i) Jog feed (See Section III-3.2)
The tool moves continuously while a push button remains pressed.
- (ii) Incremental feed (See Section III-3.3)
The tool moves by the predetermined distance each time a button is pressed.
- (iii) Manual handle feed (See Section III-3.4)
By rotating the manual handle, the tool moves by the distance corresponding to the degree of handle rotation.

1.2 TOOL MOVEMENT BY PROGRAMMING – AUTOMATIC OPERATION

Automatic operation is to operate the machine according to the created program. It includes memory, MDI, and DNC operations. (See Section III-4).

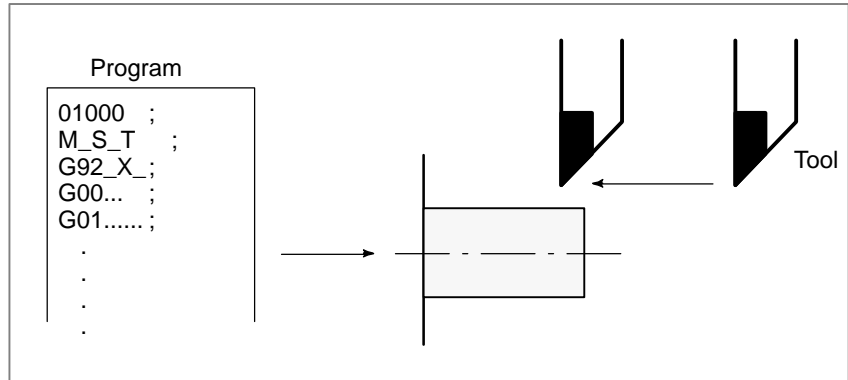

Fig. 1.2 (a) Tool Movement by Programming

Explanations

• Memory operation

After the program is once registered in memory of CNC, the machine can be run according to the program instructions. This operation is called memory operation.

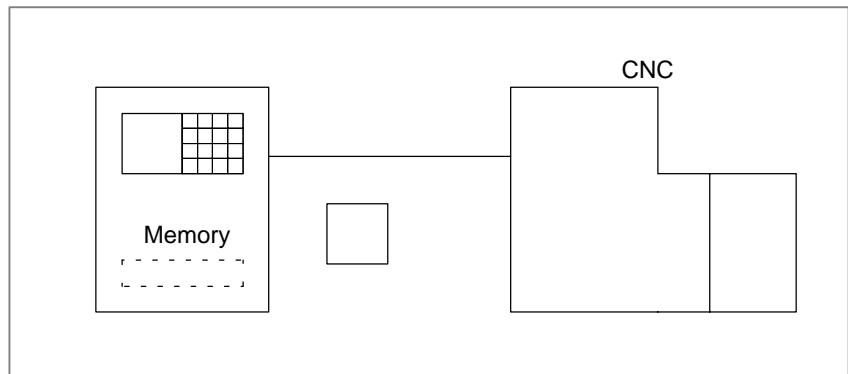

Fig. 1.2 (b) Memory Operation

• MDI operation

After the program is entered, as an command group, from the MDI keyboard, the machine can be run according to the program. This operation is called MDI operation.

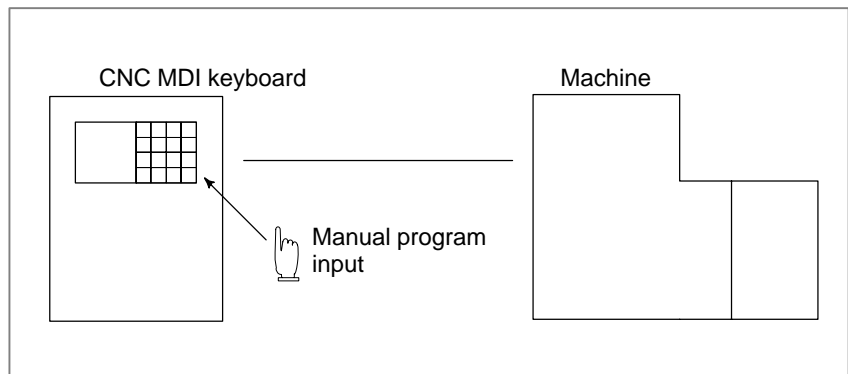

Fig. 1.2 (c) MDI operation

• DNC operation

The machine can be operated by reading a program directly from an external input/output device, without having to register the program in CNC memory. This is called DNC operation.

1.3 AUTOMATIC OPERATION

Explanations

- **Program selection**

Select the program used for the workpiece. Ordinarily, one program is prepared for one workpiece. If two or more programs are in memory, select the program to be used, by searching the program number (Section III-9.3).

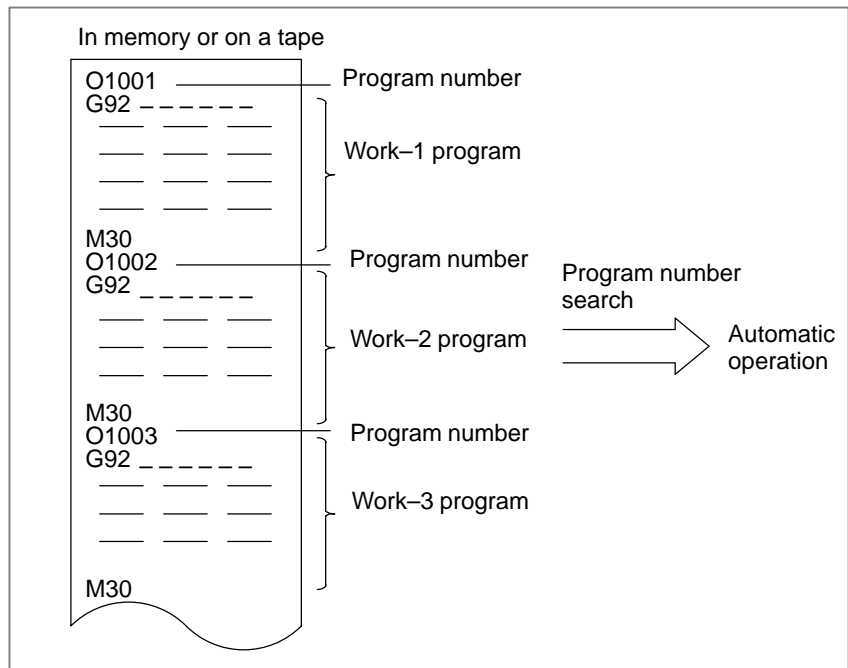

Fig. 1.3 (a) Program Selection for Automatic Operation

- **Start and stop**
(See Section III-4)

Pressing the cycle start push button causes automatic operation to start. By pressing the feed hold or reset push button, automatic operation pauses or stops. By specifying the program stop or program termination command in the program, the running will stop during automatic operation. When one process machining is completed, automatic operation stops.

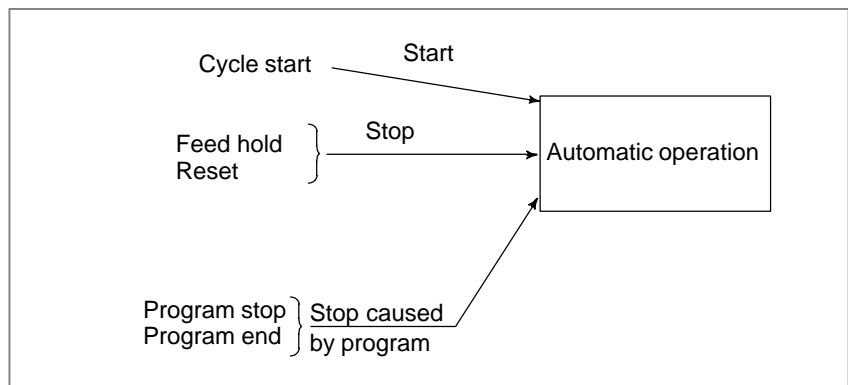

Fig. 1.3 (b) Start and Stop for Automatic Operation

- **Handle interruption (See Section III-4.6)**

While automatic operation is being executed, tool movement can overlap automatic operation by rotating the manual handle.

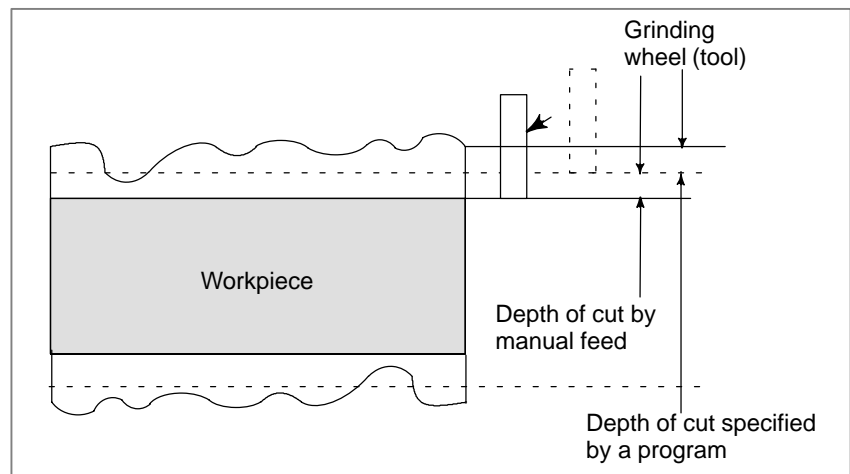

Fig. 1.3 (c) Handle Interruption for Automatic Operation

1.4 TESTING A PROGRAM

Before machining is started, the automatic running check can be executed. It checks whether the created program can operate the machine as desired. This check can be accomplished by running the machine actually or viewing the position display change (without running the machine) (See Section III-5).

1.4.1 Check by Running the Machine

Explanations

- **Dry run (See Section III-5.4)**

Remove the workpiece, check only movement of the tool. Select the tool movement rate using the dial on the operator's panel.

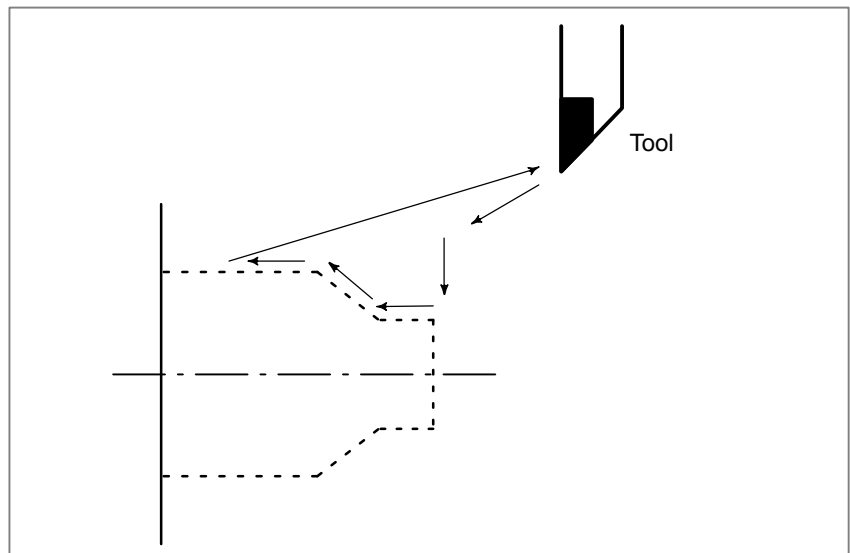

Fig. 1.4.1 (a) Dry run

- **Feedrate override (See Section III-5.2)**

Check the program by changing the rate specified in the program.

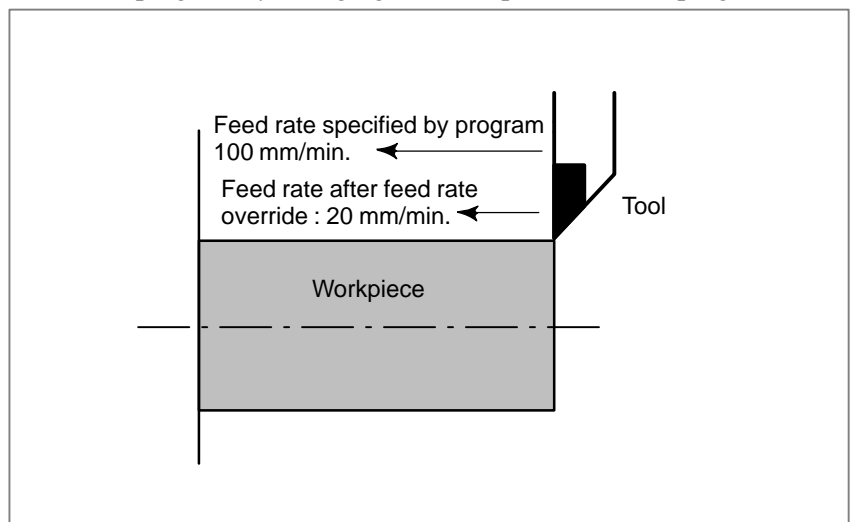

Fig. 1.4.1 (b) Feedrate Override

• **Single block (See Section III-5.5)**

When the cycle start push button is pressed, the tool executes one operation then stops. By pressing the cycle start again, the tool executes the next operation then stops. The program is checked in this manner.

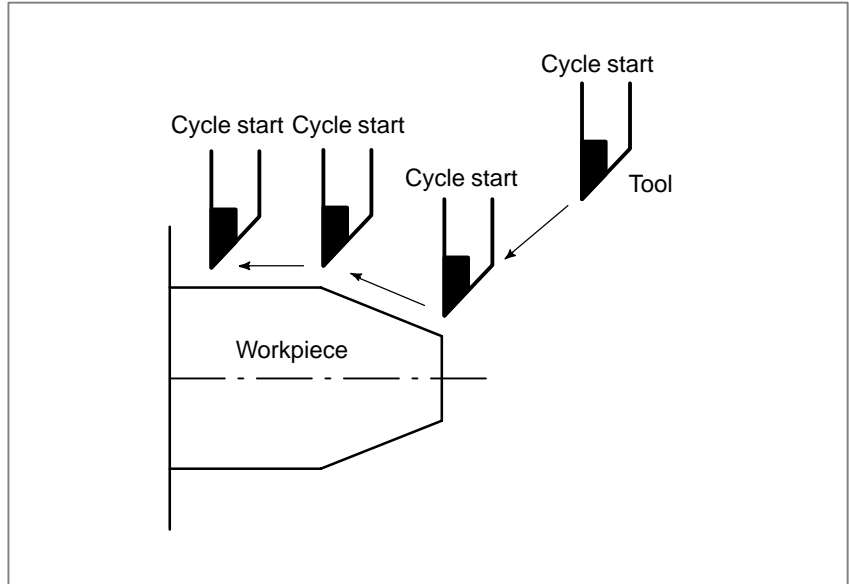

Fig. 1.4.1 (c) Single Block

1.4.2 How to View the Position Display Change without Running the Machine

Explanations

• **Machine lock**

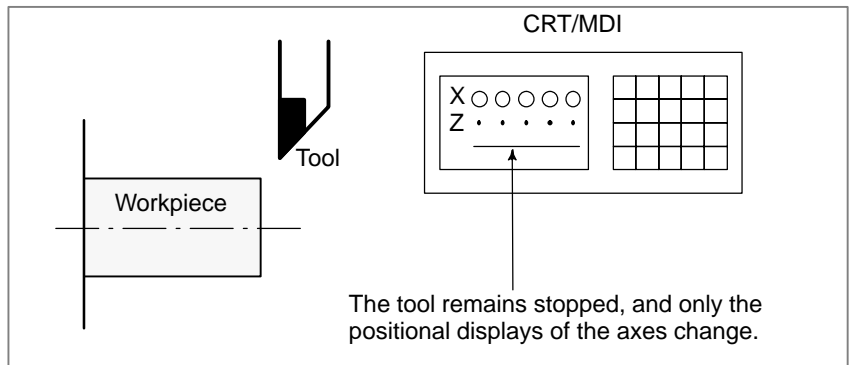

Fig. 1.4.2 Machine Lock

• **Auxiliary function lock**

When automatic running is placed into the auxiliary function lock mode during the machine lock mode, all auxiliary functions (spindle rotation, tool replacement, coolant on/off, etc.) are disabled. (See Section III-5.1)

1.5 EDITING A PART PROGRAM

After a created program is once registered in memory, it can be corrected or modified from the MDI panel (See Section III-9). This operation can be executed using the part program storage/edit function.

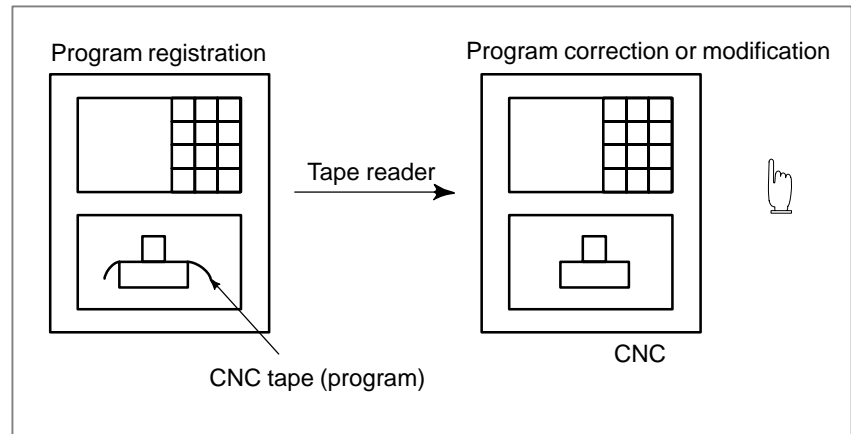

Fig. 1.5 Part Program Editing

1.6 DISPLAYING AND SETTING DATA

The operator can display or change a value stored in CNC internal memory by key operation on the MDI screen (See III-11).

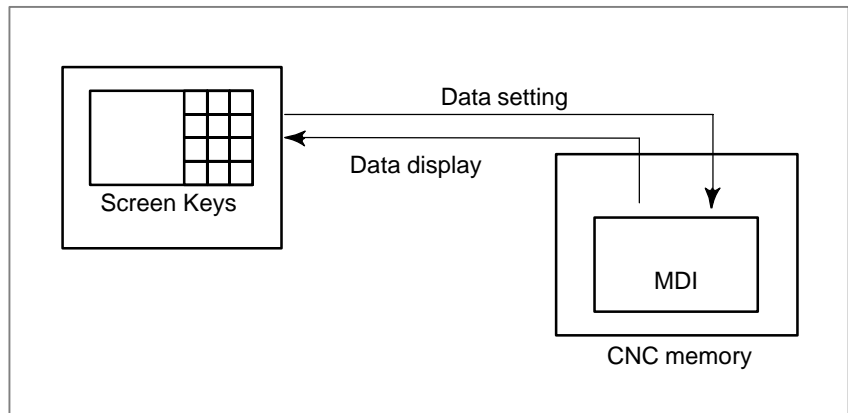

Fig. 1.6 (a) Displaying and Setting Data

Explanations

- Offset value

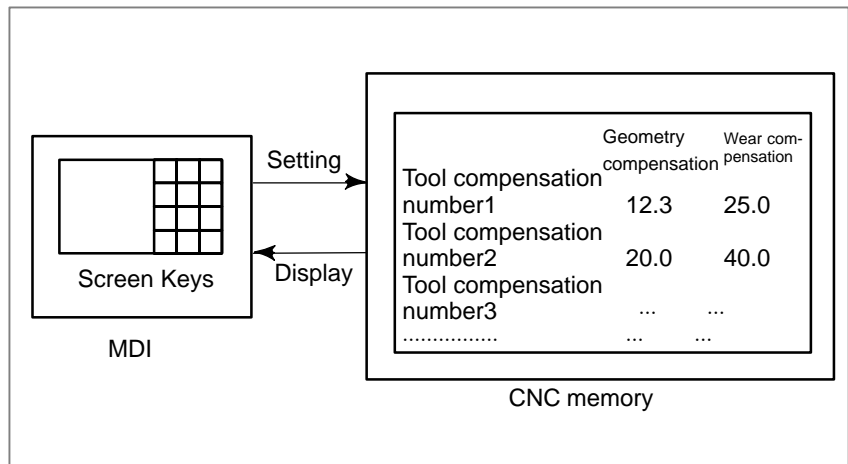

Fig. 1.6 (b) Displaying and Setting Offset Values

The tool has the tool dimension (length, diameter). When a workpiece is machined, the tool movement value depends on the tool dimensions. By setting tool dimension data in CNC memory beforehand, automatically generates tool routes that permit any tool to cut the workpiece specified by the program. Tool dimension data is called the offset value (See Section III-11.4.1).

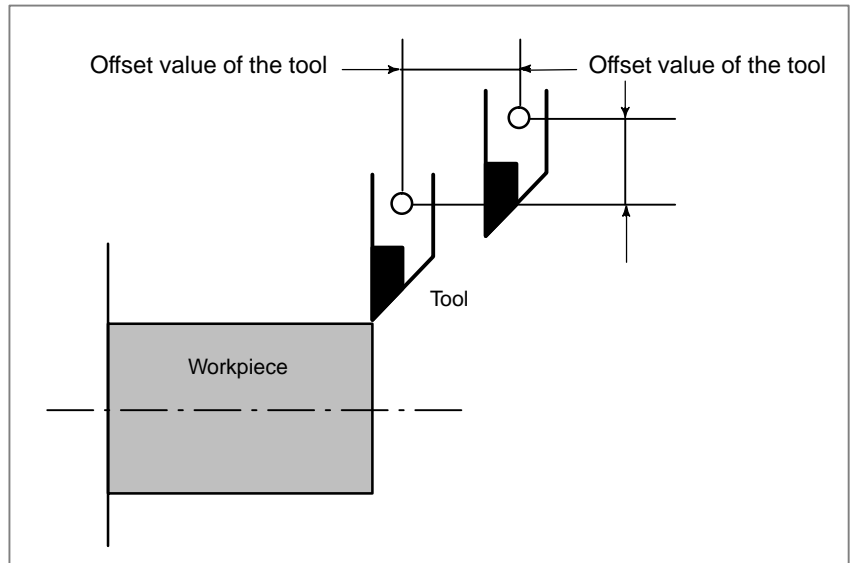

Fig. 1.6 (c) Offset Value

- **Displaying and setting operator's setting data**

Apart from parameters, there is data that is set by the operator in operation. This data causes machine characteristics to change.

For example, the following data can be set:

- Inch/Metric switching
- I/O devices selection
- Mirror image cutting on/off

The above data is called setting data (See Section III-11.4.7).

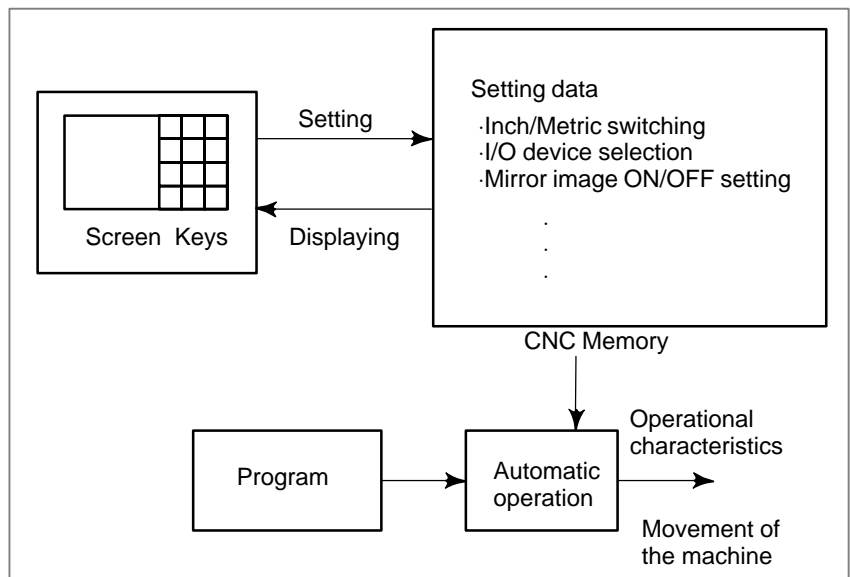

Fig. 1.6 (d) Displaying and Setting Operator's setting data

• **Displaying and setting parameters**

The CNC functions have versatility in order to take action in characteristics of various machines.

For example, CNC can specify the following:

- Rapid traverse rate of each axis
- Whether increment system is based on metric system or inch system.
- How to set command multiply/detect multiply (CMR/DMR)

Data to make the above specification is called parameters (See Section III-11.5.1).

Parameters differ depending on machine tool.

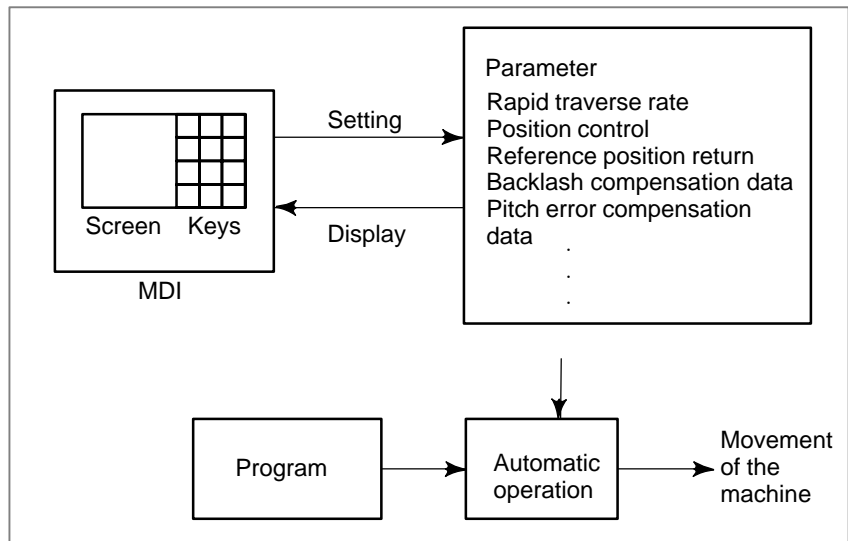

Fig. 1.6 (e) Displaying and setting parameters

• **Data protection key**

A key called the data protection key can be defined. It is used to prevent part programs, offset values, parameters, and setting data from being registered, modified, or deleted erroneously (See Section III-11).

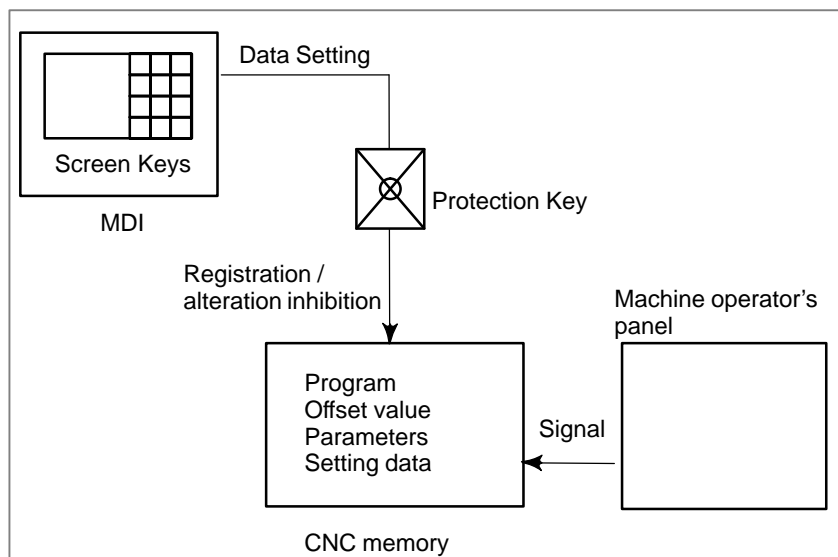
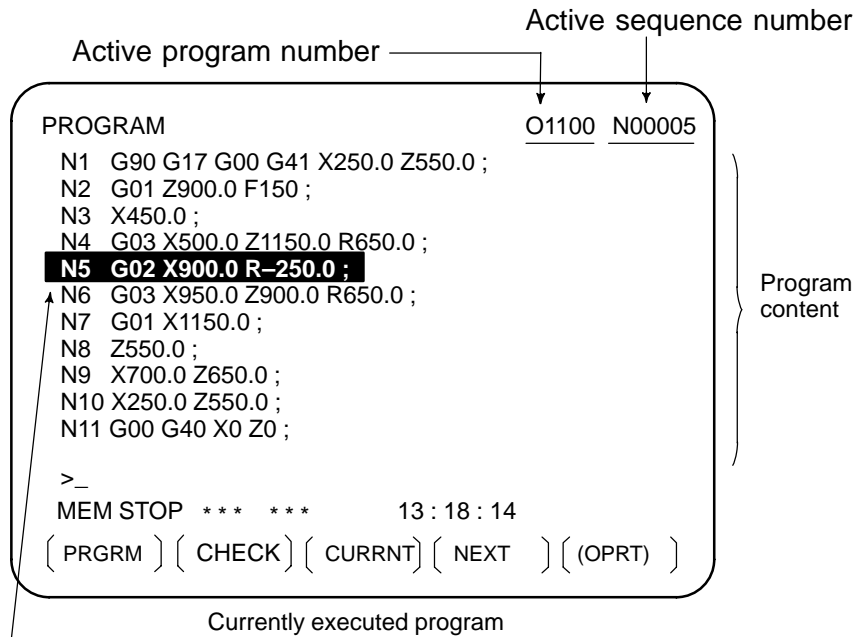

Fig. 1.6 (f) Data Protection Key

1.7 DISPLAY

1.7.1 Program Display

The contents of the currently active program are displayed. In addition, the programs scheduled next and the program list are displayed. (See Section III-11.2.1)



The cursor indicates the currently executed location

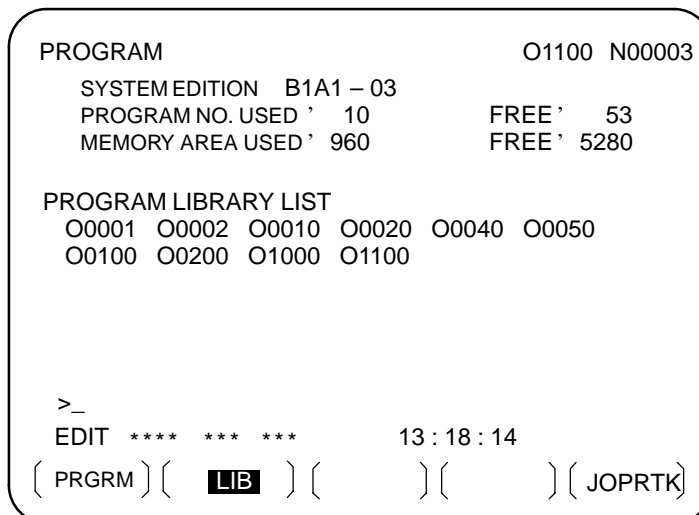

1.7.2 Current Position Display

The current position of the tool is displayed with the coordinate values. The distance from the current position to the target position can also be displayed. (See Section III-11.1 to 11.1.3)

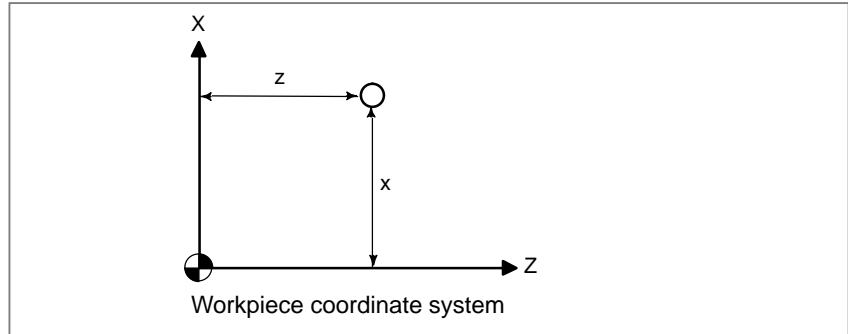

```

ACTUAL POSITION(ABSOLUTE)    O1000 N00010

  X      123.456
  Z      456.789
  C      90.000

                PART COUNT    5
RUN TIME  0H15M  CYCLE TIME  0H 0M38S

MEM STRT MTN ***    09:06:35
[ ABS ] [ REL ] [ ALL ] [ HNDL ] [ ] [(OPRT)]
    
```

1.7.3 Alarm Display

When a trouble occurs during operation, error code and alarm message are displayed on CRT screen. See APPENDIX G for the list of error codes and their meanings. (See Section III-7.1)

```

ALARM MESSAGE                O1000 N00003

010    IMPROPER G-CODE

>_
MEM STOP *****    ***  [ ALM ] 19:55:22
[ [ALARM] ] [ MSG ] [ HISTRY ] [ ] [ ]
    
```



1.7.4 Parts Count Display, Run Time Display

When this option is selected, two types of run time and number of parts are displayed on the screen. (See Section III-11.4.9)

ACTUAL POSITION(ABSOLUTE)		O1000 N00010
X	123.456	
Z	456.789	
C	90.000	
RUN TIME 0H15M		PART COUNT 5
CYCLE TIME 0H 0M38S		
MEM STRT MTN ***		09:06:35
[ABS]	[REL]	[ALL] [HNDL] [] [(OPRT)]

1.7.5 Graphic Display (See Section III-12)

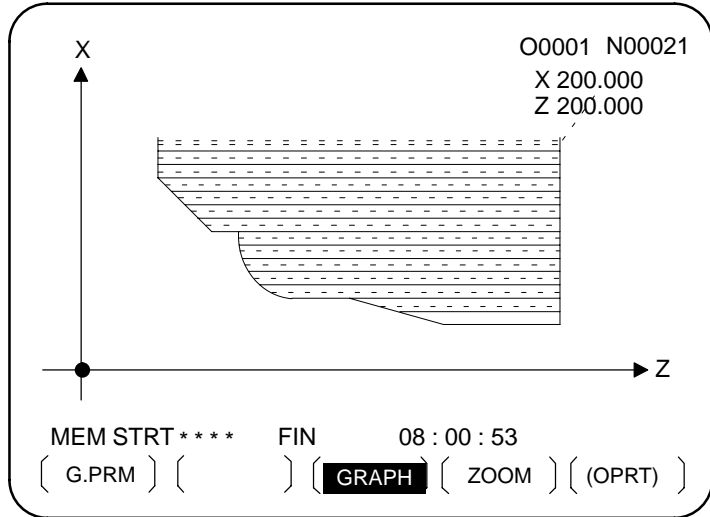
The graphic can be used to draw a tool path for automatic operation and manual operation, thereby indicating the progress of cutting and the position of the tool. (See Section III-12)



1-path control

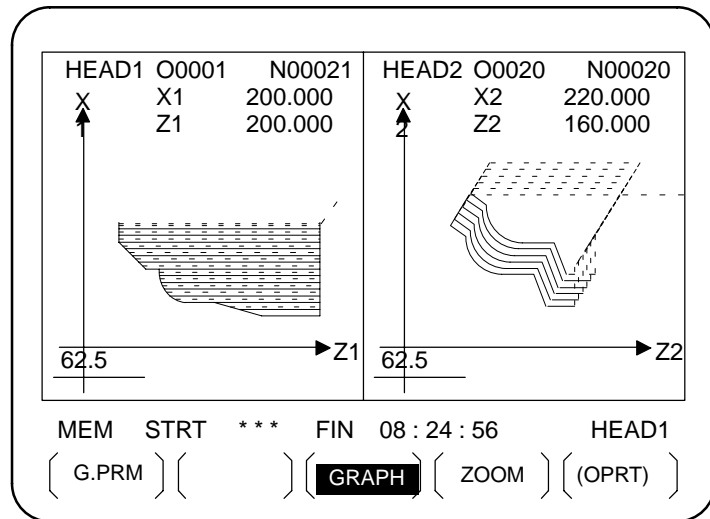

2-path control

1.8 DATA OUTPUT

Programs, offset values, parameters, etc. input in CNC memory can be output to paper tape, cassette, or a floppy disk for saving. After once output to a medium, the data can be input into CNC memory. (See III-8.)

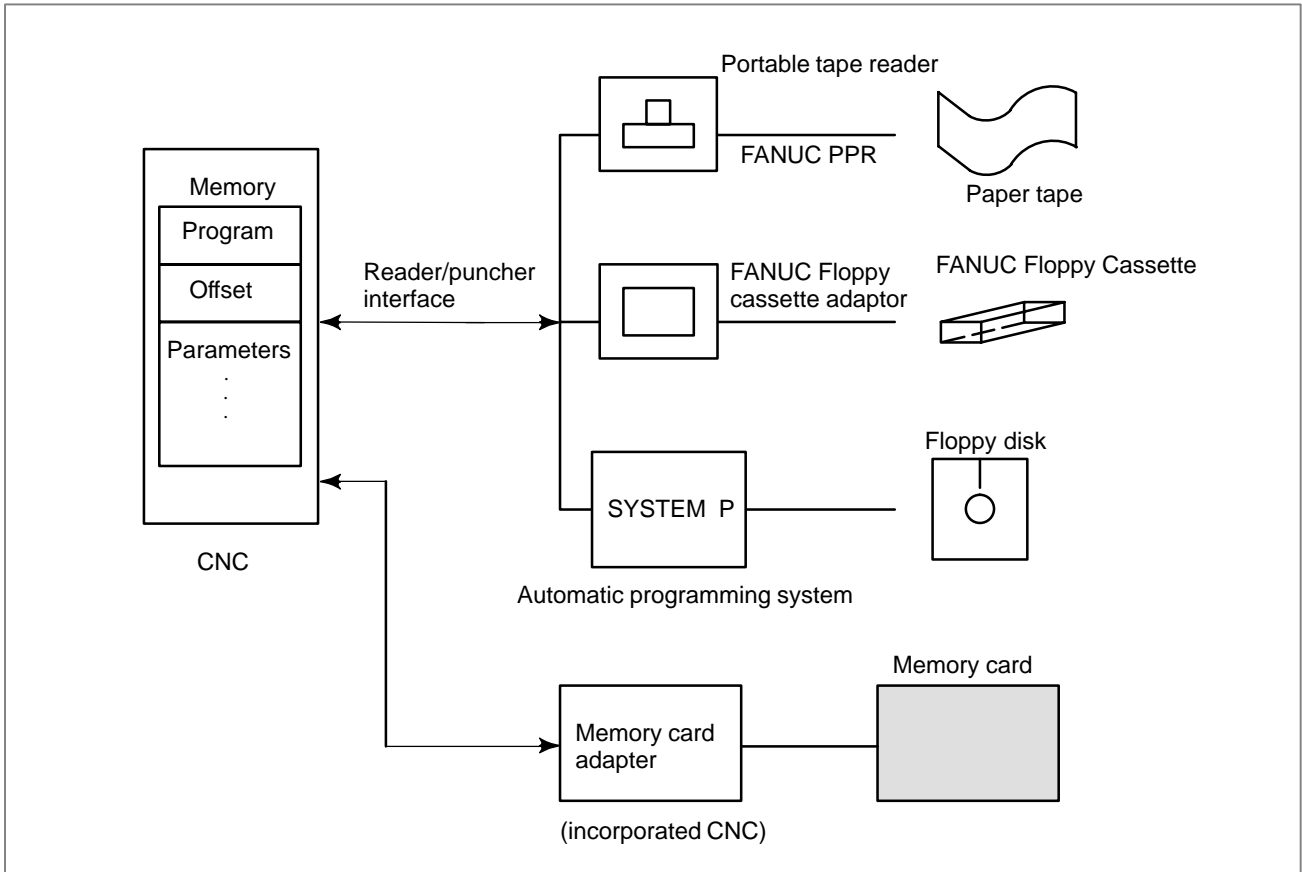



Fig. 1.8 Data Output

2

OPERATIONAL DEVICES



The available operational devices include the setting and display unit attached to the CNC, the machine operator's panel, and external input/output devices such as a Handy File and etc.

2.1 SETTING AND DISPLAY UNITS

The setting and display units are shown in Subsections 2.1.1 to 2.1.5 of Part III.

7.2"/8.4" LCD-mounted type CNC control unit: III-2.1.1

9.5"/10.4" LCD-mounted type CNC control unit: III-2.1.2

Stand-Alone type small MDI unit: III-2.1.3

Stand-Alone type standard MDI unit: III-2.1.4

Stand-Alone type 61 full key MDI unit: III-2.1.5

2.1.1
7.2"/8.4" LCD-mounted
Type CNC Control Unit

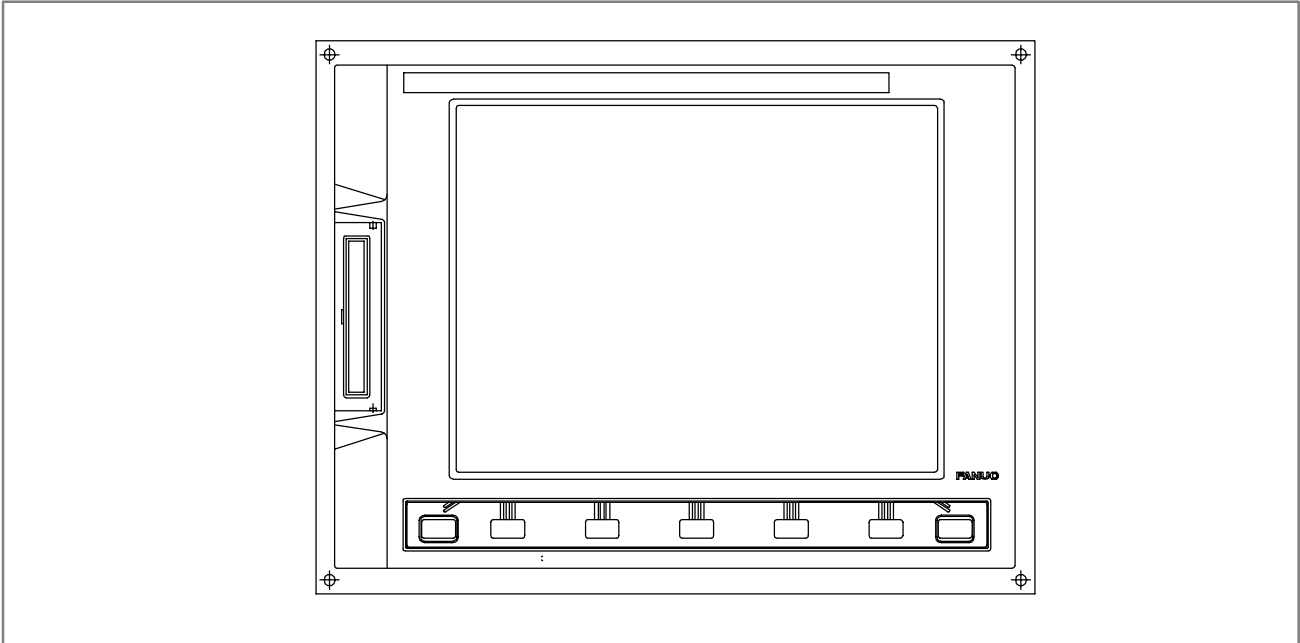

2.1.2
9.5"/10.4"
LCD-mounted Type
CNC Control Unit

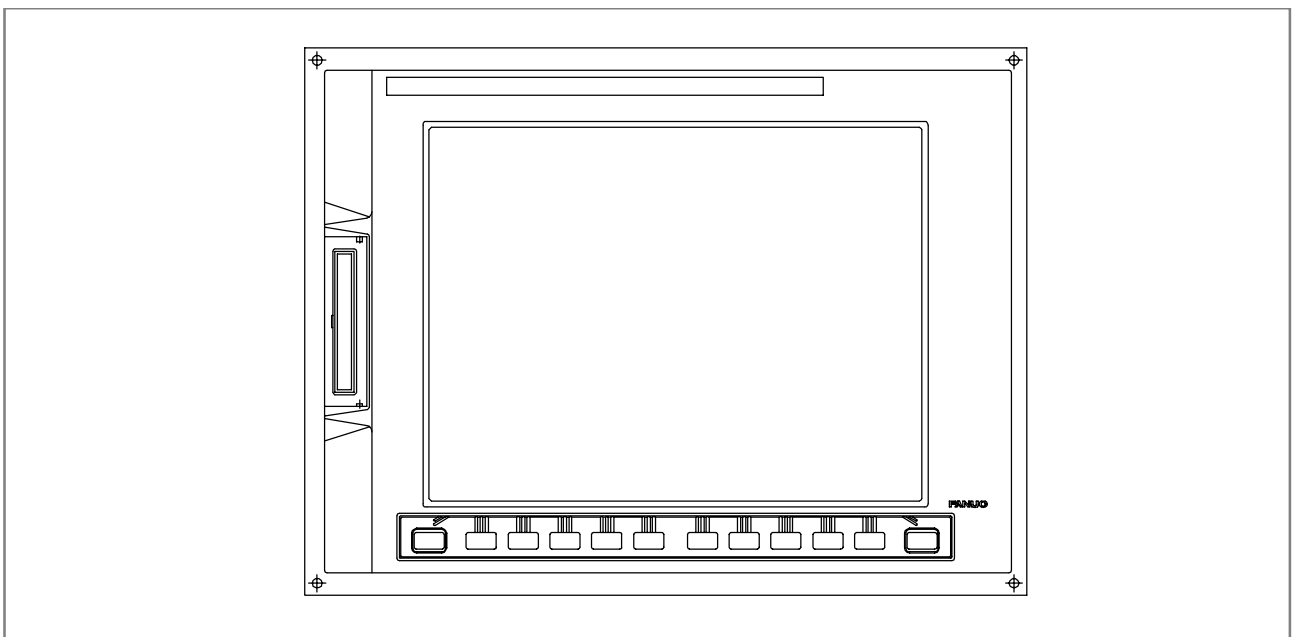

2.1.3 Stand-alone Type Small MDI Unit

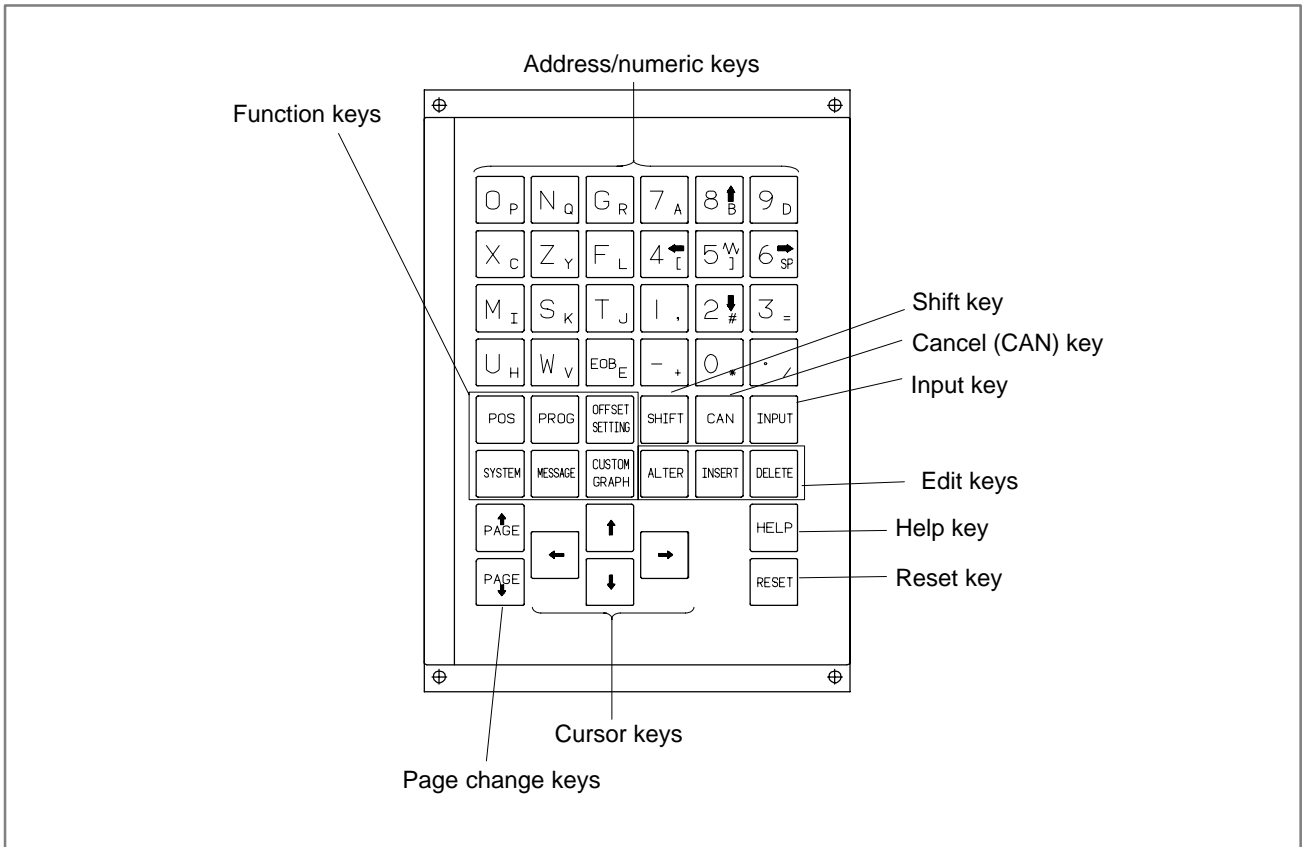

2.1.4 Stand-alone Type Standard MDI Unit

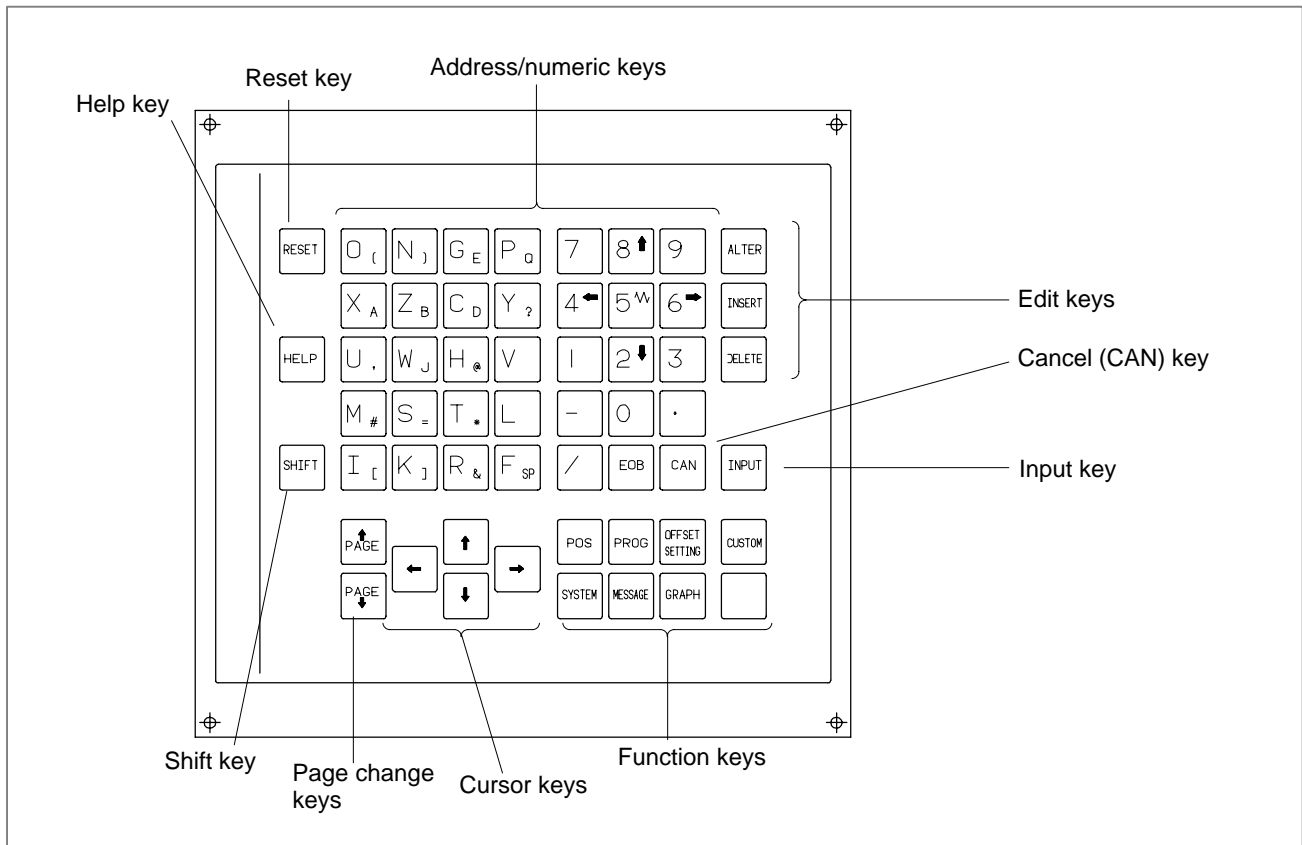

2.1.5 Stand-alone Type 61 Full Key MDI Unit

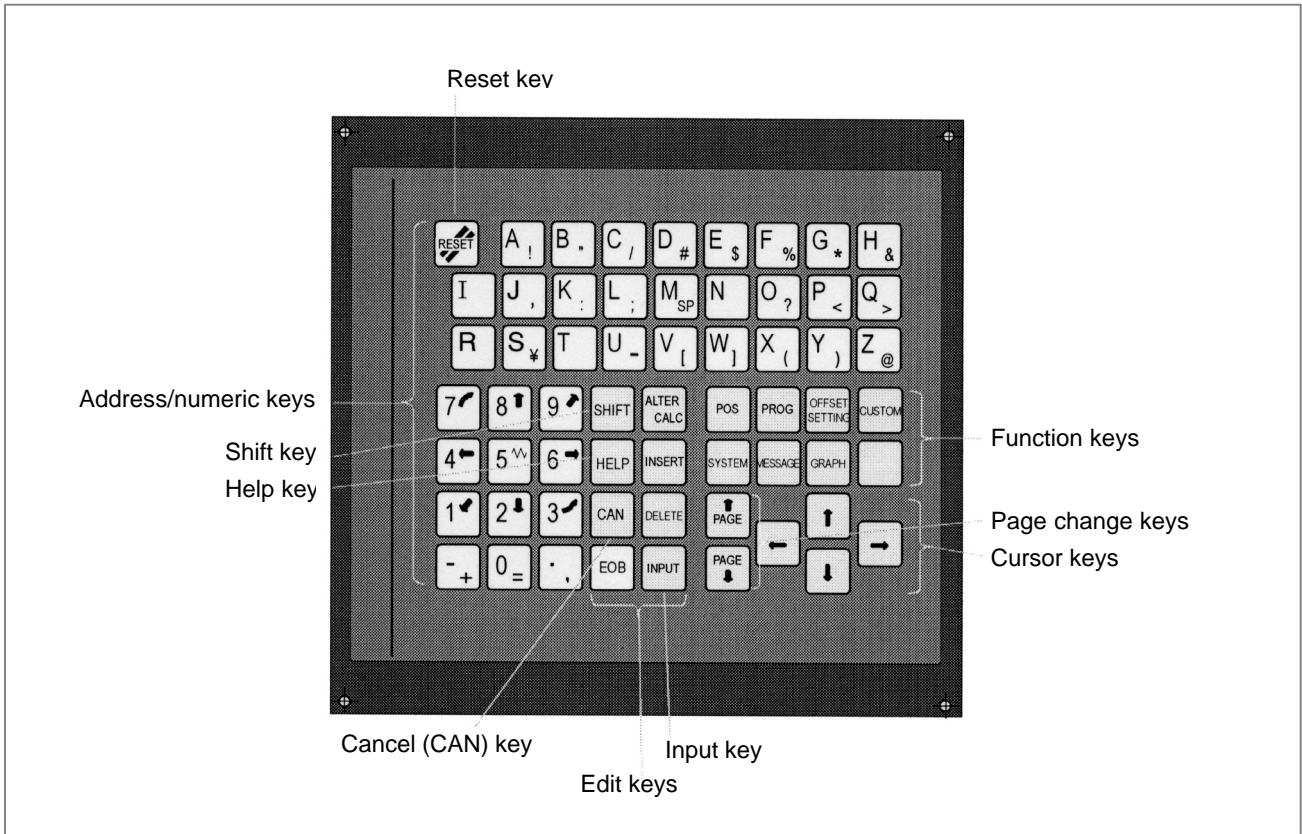

2.2 EXPLANATION OF THE KEYBOARD

Table 2.2 Explanation of the MDI keyboard























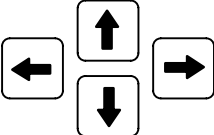

Number	Name	Explanation
1	RESET key 	Press this key to reset the CNC, to cancel an alarm, etc.
2	HELP key 	Press this key to display how to operate the machine tool, such as MDI key operation, or the details of an alarm which occurred in the CNC (Help function). In case of 160i/180i/160is/180is, this key is assigned to "ESC" key of the personal computer.
3	Soft keys	The soft keys have various functions, according to the Applications. The soft key functions are displayed at the bottom of the CRT screen.
4	Address and numeric keys   ...	Press these keys to input alphabetic, numeric, and other characters.
5	SHIFT key 	Some keys have two characters on their keytop. Pressing the <SHIFT> key switches the characters. Special character È is displayed on the screen when a character indicated at the bottom right corner on the keytop can be entered.
6	INPUT key 	When an address or a numerical key is pressed, the data is input to the buffer, and it is displayed on the CRT screen. To copy the data in the key input buffer to the offset register, etc., press the <INPUT> key. This key is equivalent to the [INPUT] key of the soft keys, and either can be pressed to produce the same result.
7	Cancel key 	Press this key to delete the last character or symbol input to the key input buffer. When the key input buffer displays >N001X100Z_ and the cancel  key is pressed, Z is canceled and >N001X100_ is displayed.
8	Program edit keys   	Press these keys when editing the program.  : Alteration (In case of 160i/180i/160is/180is, this key is assigned to "Tab" key of the personal computer.)  : Insertion  : Deletion
9	Function keys   ...	Press these keys to switch display screens for each function. See sec. 2.3 for details of the function keys.

Table 2.2 Explanation of the MDI keyboard

Number	Name	Explanation
10	Cursor move keys 	There are four different cursor move keys.  : This key is used to move the cursor to the right or in the forward direction. The cursor is moved in short units in the forward direction.  : This key is used to move the cursor to the left or in the reverse direction. The cursor is moved in short units in the reverse direction.  : This key is used to move the cursor in a downward or forward direction. The cursor is moved in large units in the forward direction.  : This key is used to move the cursor in an upward or reverse direction. The cursor is moved in large units in the reverse direction.
11	Page change keys 	Two kinds of page change keys are described below.  : This key is used to changeover the page on the screen in the forward direction.  : This key is used to changeover the page on the screen in the reverse direction.

2.3 FUNCTION KEYS AND SOFT KEYS

The function keys are used to select the type of screen (function) to be displayed. When a soft key (section select soft key) is pressed immediately after a function key, the screen (section) corresponding to the selected function can be selected.

2.3.1 General Screen Operations

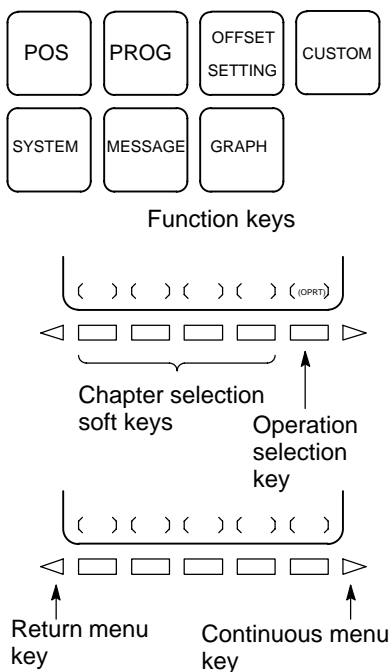

- 1 Press a function key on the MDI panel. The chapter selection soft keys that belong to the selected function appear.
- 2 Press one of the chapter selection soft keys. The screen for the selected chapter appears. If the soft key for a target chapter is not displayed, press the continuous menu key (next-menu key). In some cases, additional chapters can be selected within a chapter.
- 3 When the target chapter screen is displayed, press the operation selection key to display data to be manipulated.
- 4 To redisplay the chapter selection soft keys, press the return menu key.

The general screen display procedure is explained above. However, the actual display procedure varies from one screen to another. For details, see the description of individual operations.

2.3.2 Function Keys

Function keys are provided to select the type of screen to be displayed. The following function keys are provided on the MDI panel:



Press this key to display the **position screen**.



Press this key to display the **program screen**.



Press this key to display the **offset/setting screen**.



Press this key to display the **system screen**.



Press this key to display the **message screen**.

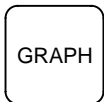

Press this key to display the **graphics screen**.



Press this key to display the **custom screen (conversational macro screen)**.

In case of 160i/180i, this key is assigned to “Ctrl” key of the personal computer.

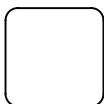

In case of 160i/180i, this key is assigned to “Alt” key of the personal computer.

2.3.3 Soft Keys

To display a more detailed screen, press a function key followed by a soft key. Soft keys are also used for actual operations.

The following illustrates how soft key displays are changed by pressing each function key.

The symbols in the following figures mean as shown below :



: Indicates screens



: Indicates a screen that can be displayed by pressing a function key(*1)



: Indicates a soft key(*2)



: Indicates input from the MDI panel.



: Indicates a soft key displayed in green (or highlighted).



: Indicates the continuous menu key (rightmost soft key)(*3).

*1 Press function keys to switch between screens that are used frequently.

*2 Some soft keys are not displayed depending on the option configuration.

*3 In some cases, the continuous menu key will not appear when a 12 soft key display unit is used.

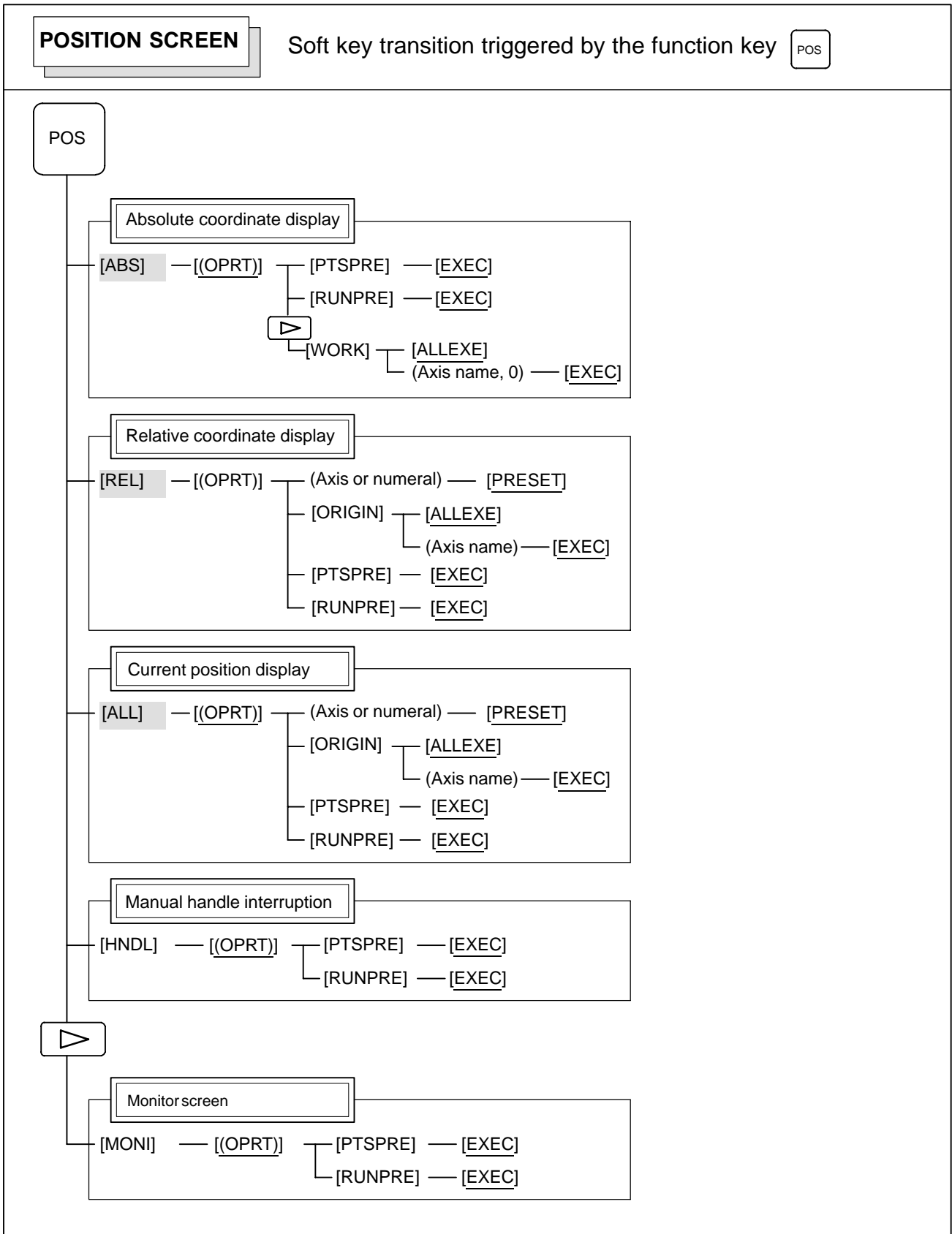

PROGRAM SCREEN

Soft key transition triggered by the function key in the MEM mode

PROG

1/2

PROG

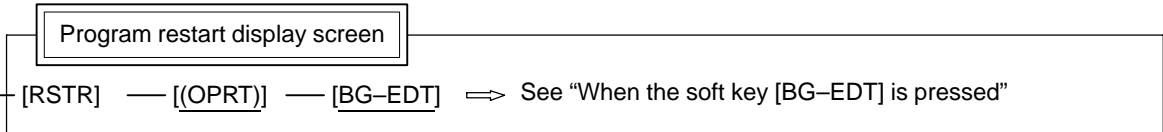
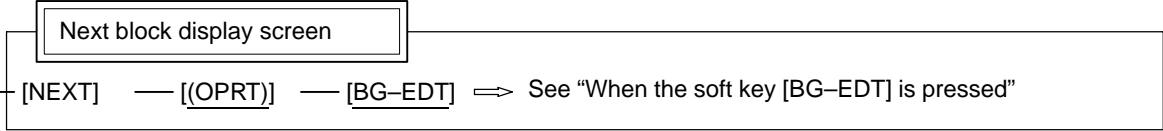
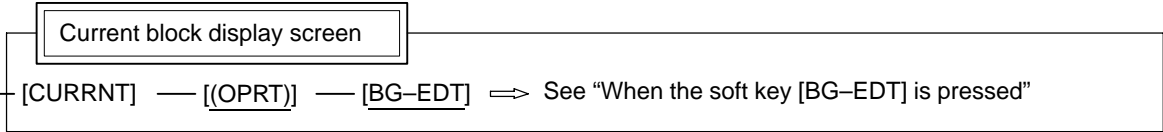
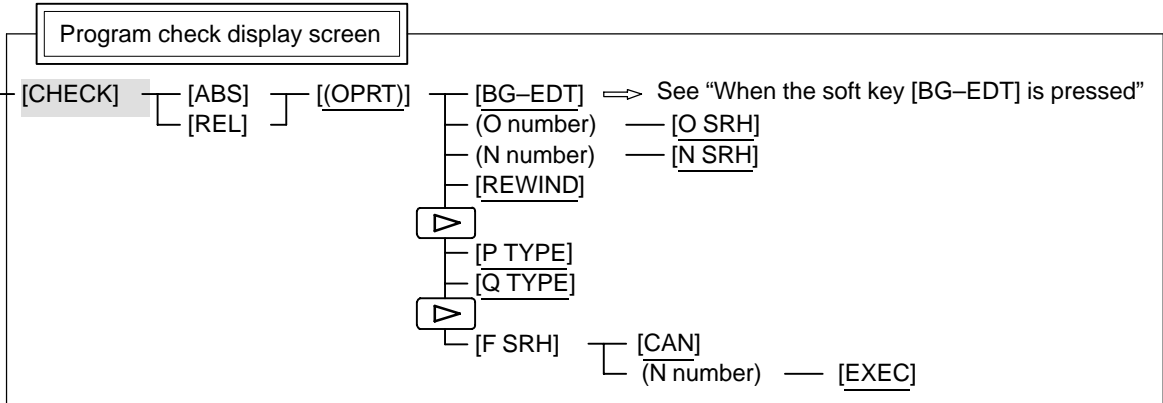
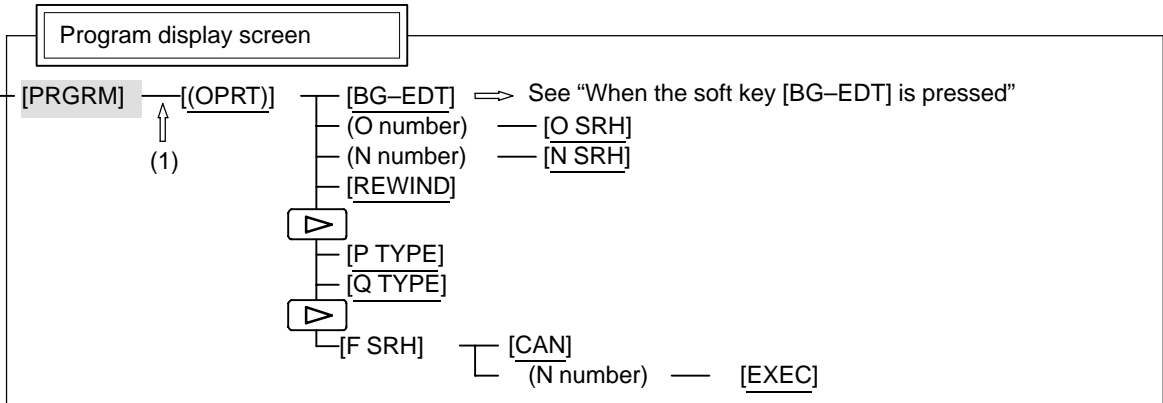

(2) (Continued on the next page)

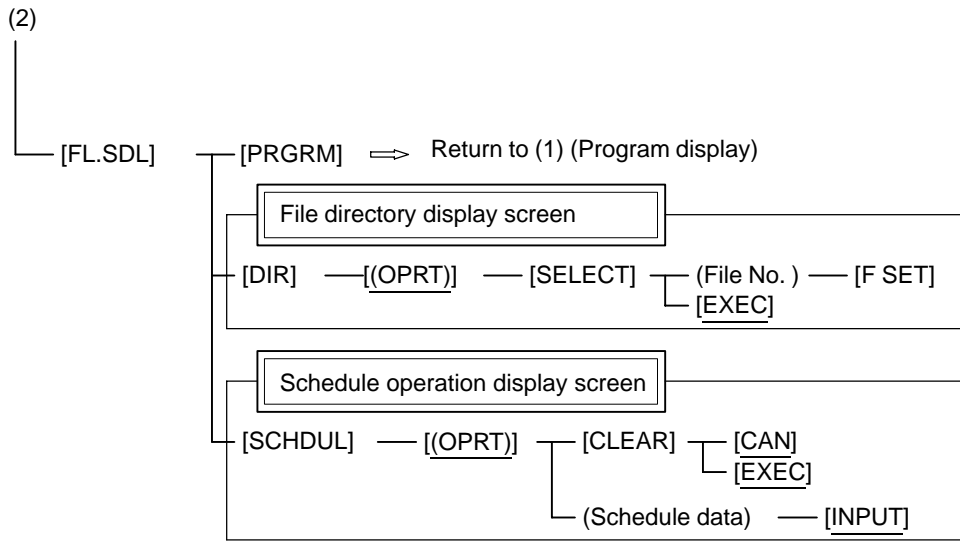

PROGRAM SCREEN

Soft key transition triggered by the function key in the EDIT mode

PROG

1/2

PROG

Program display

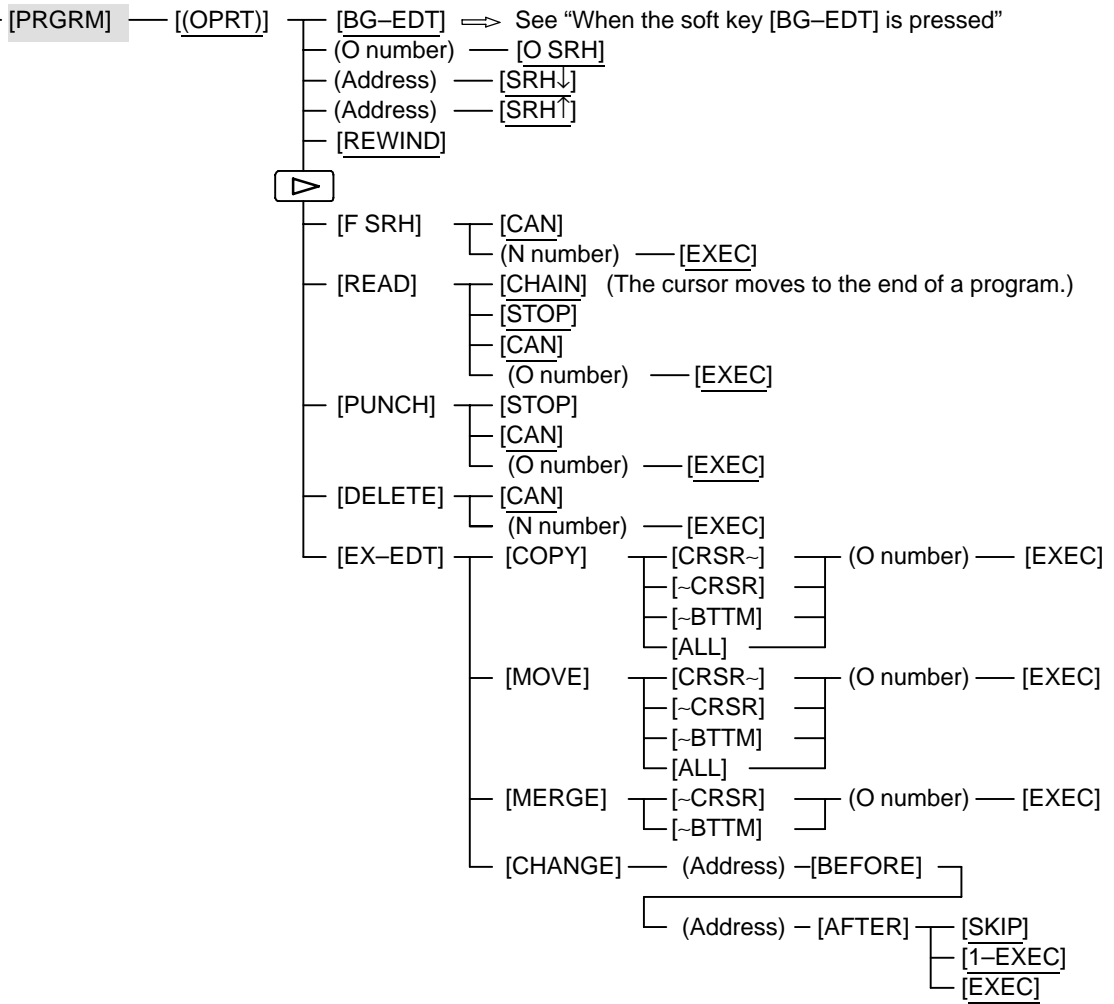

(1) (Continued on the next page)

(1)

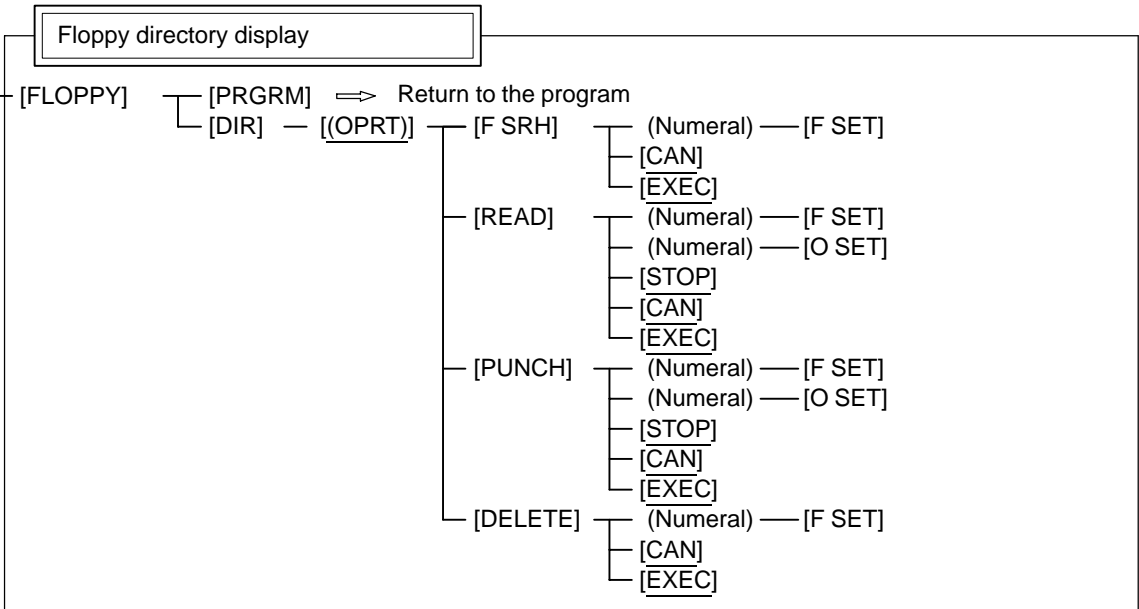
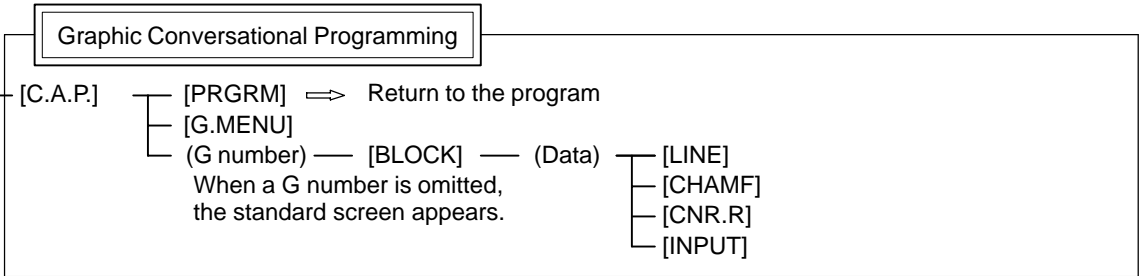
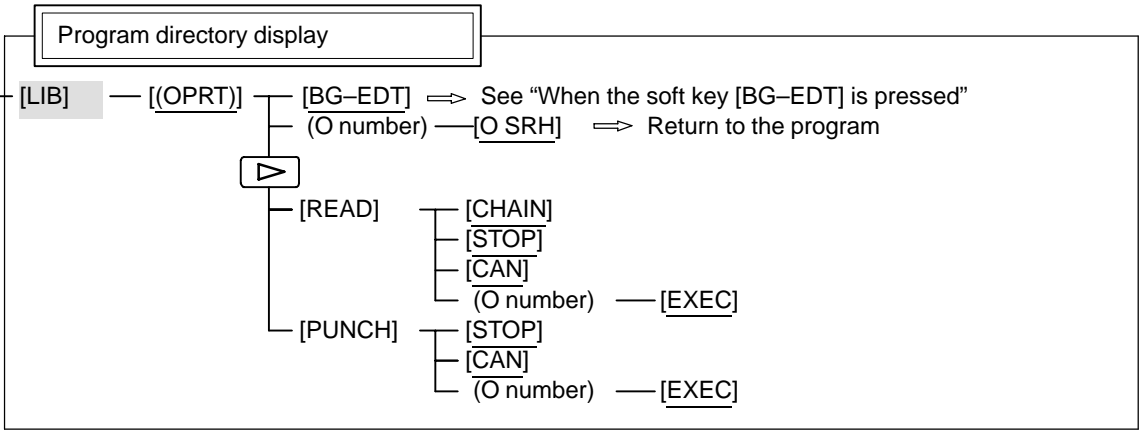

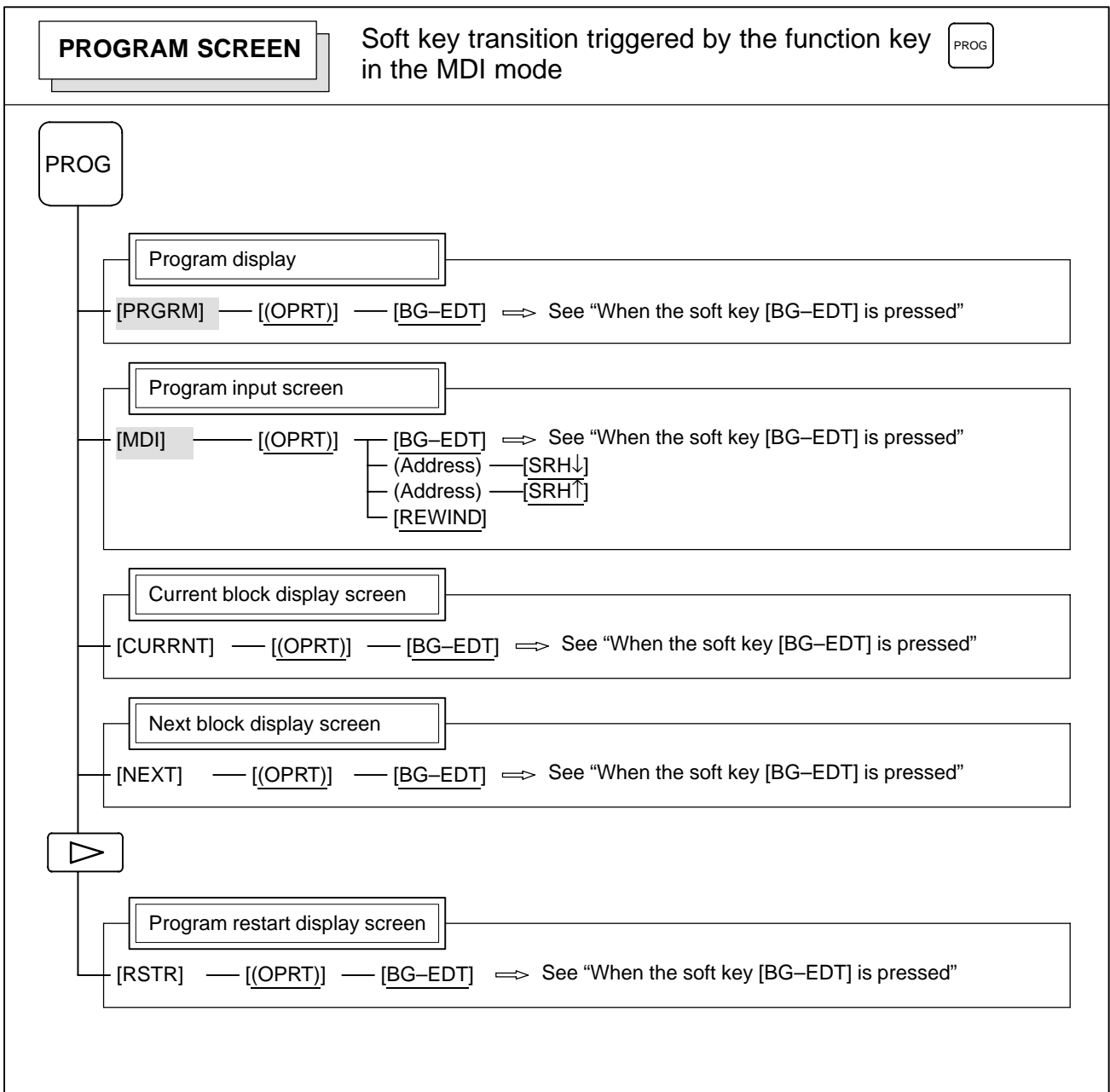

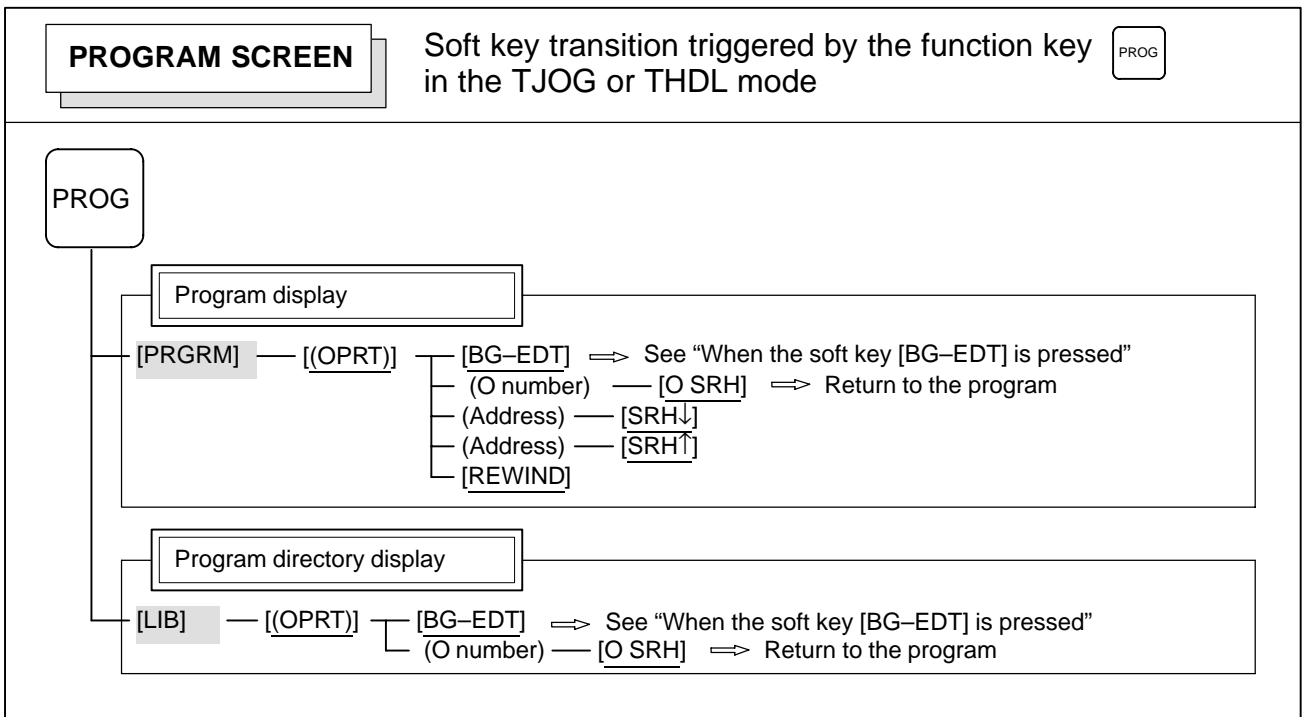
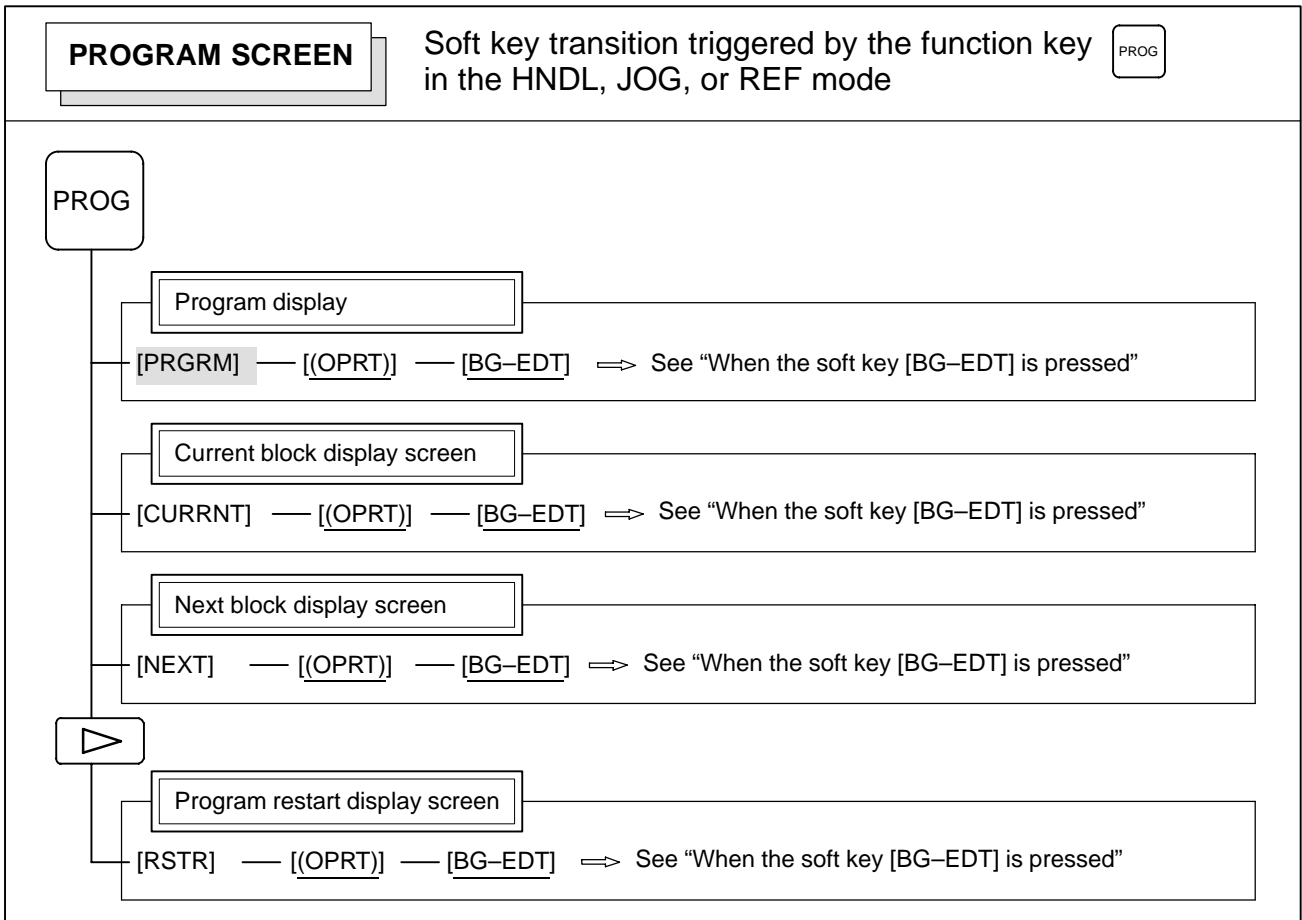

PROGRAM SCREEN

Soft key transition triggered by the function key PROG
 (When the soft key [BG-EDT] is pressed in all modes)

1/2

PROG

Program display

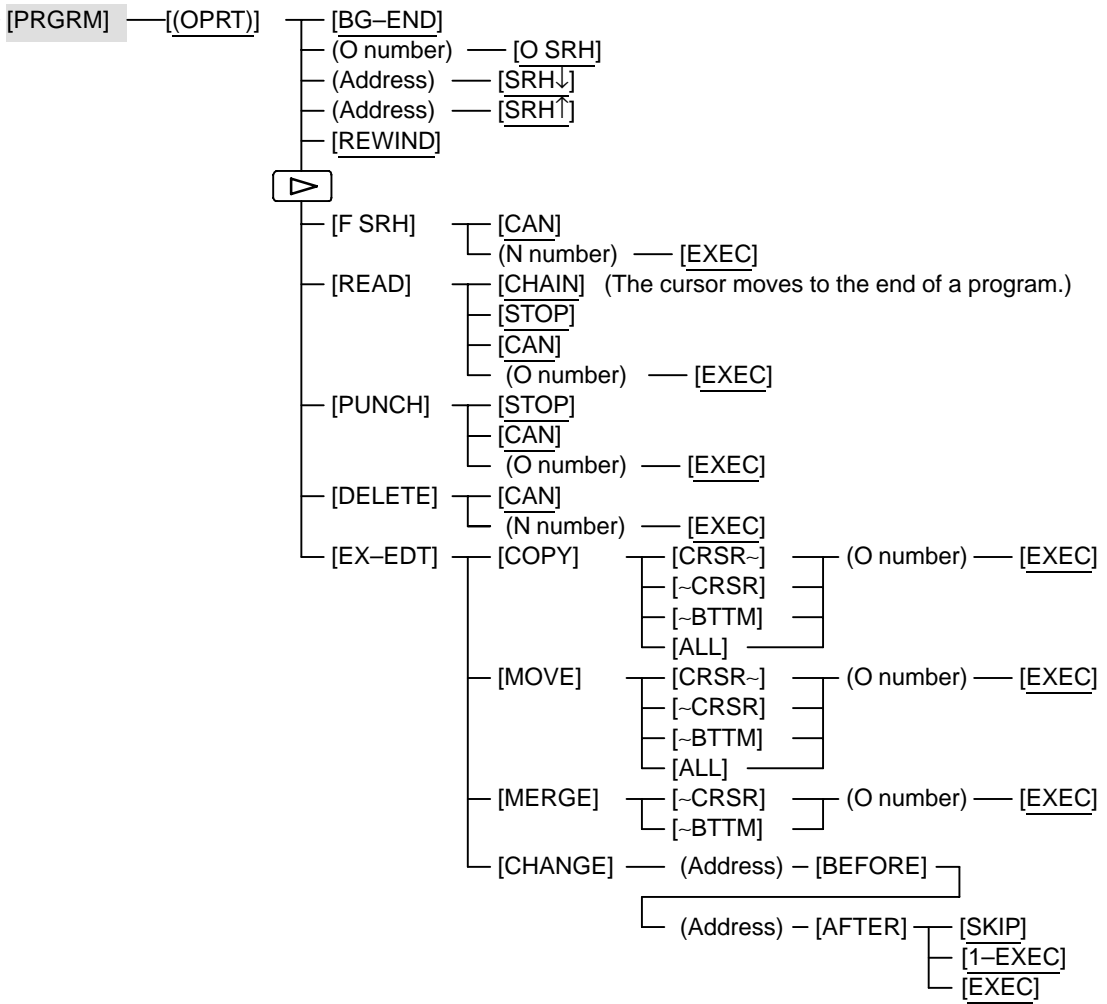

(1) (Continued on the next page)

(1)

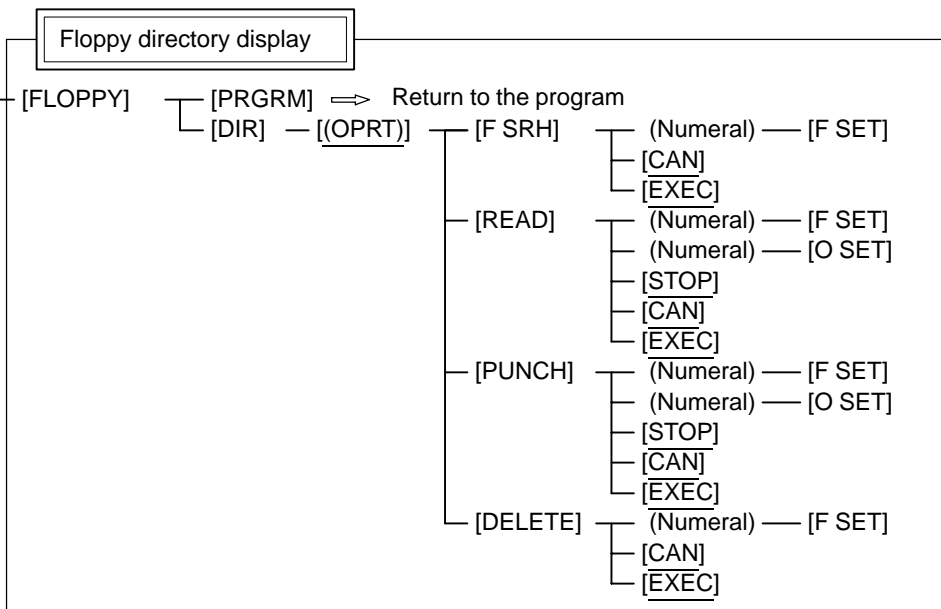
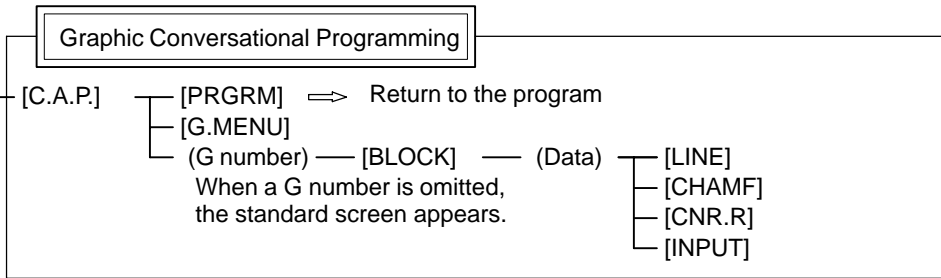
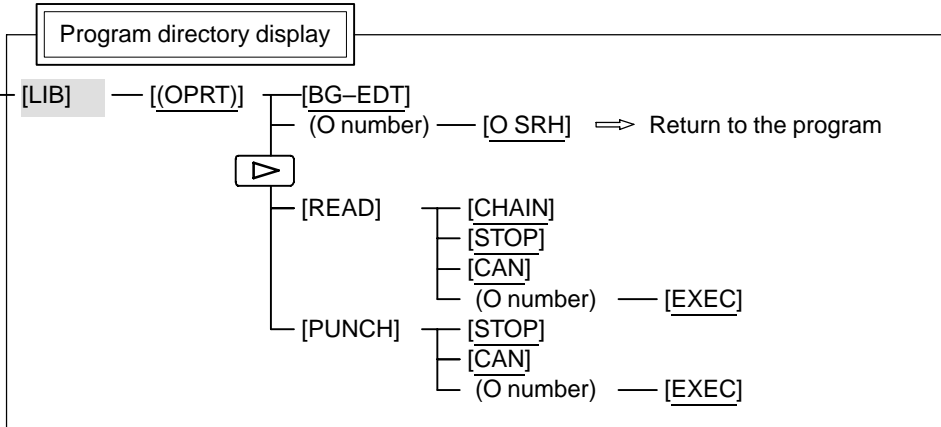

OFFSET/SETTING SCREEN

Soft key transition triggered by the function key

OFFSET
SETTING

1/2

OFFSET
SETTING

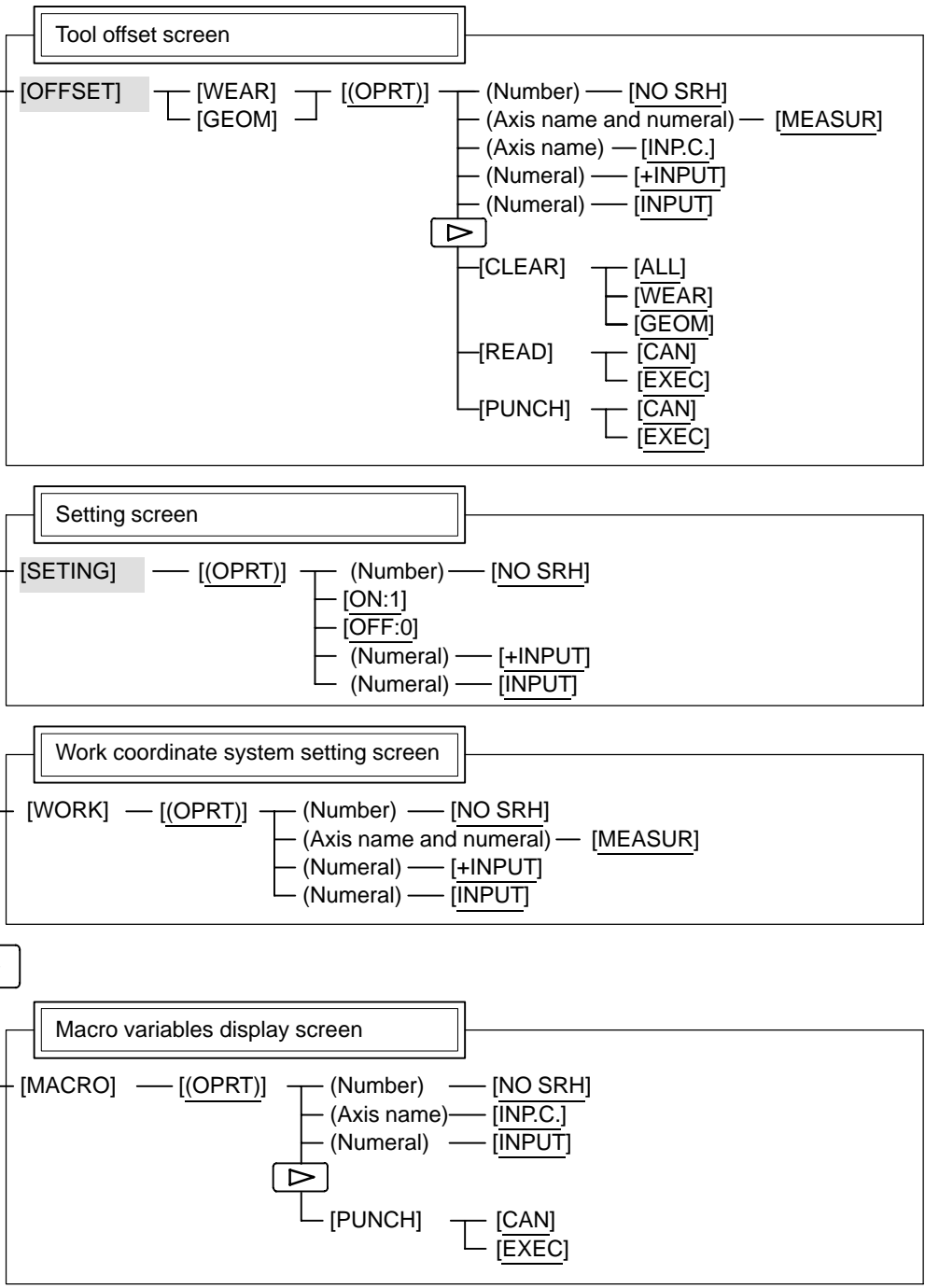

(1) (Continued on the next page)

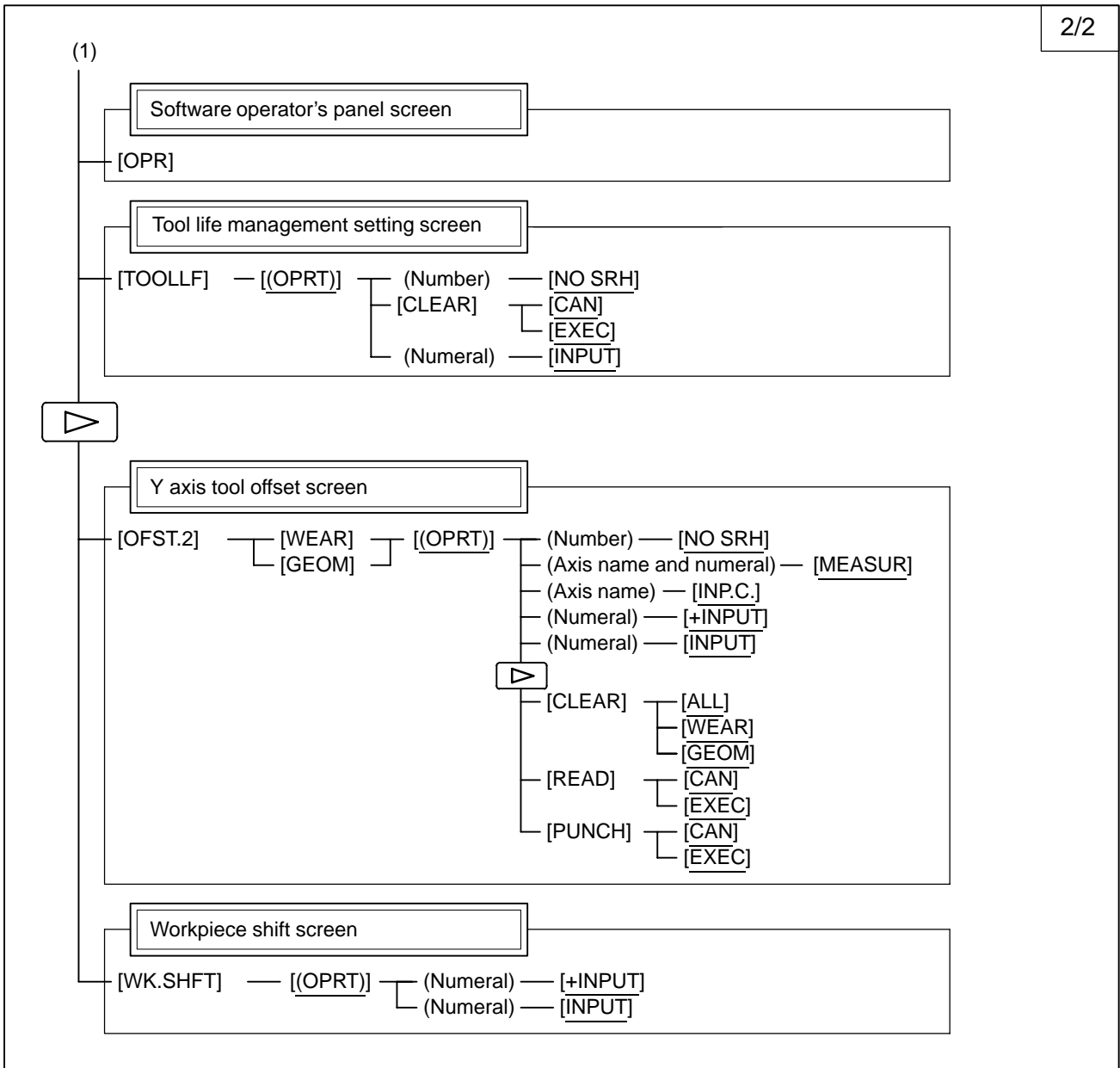

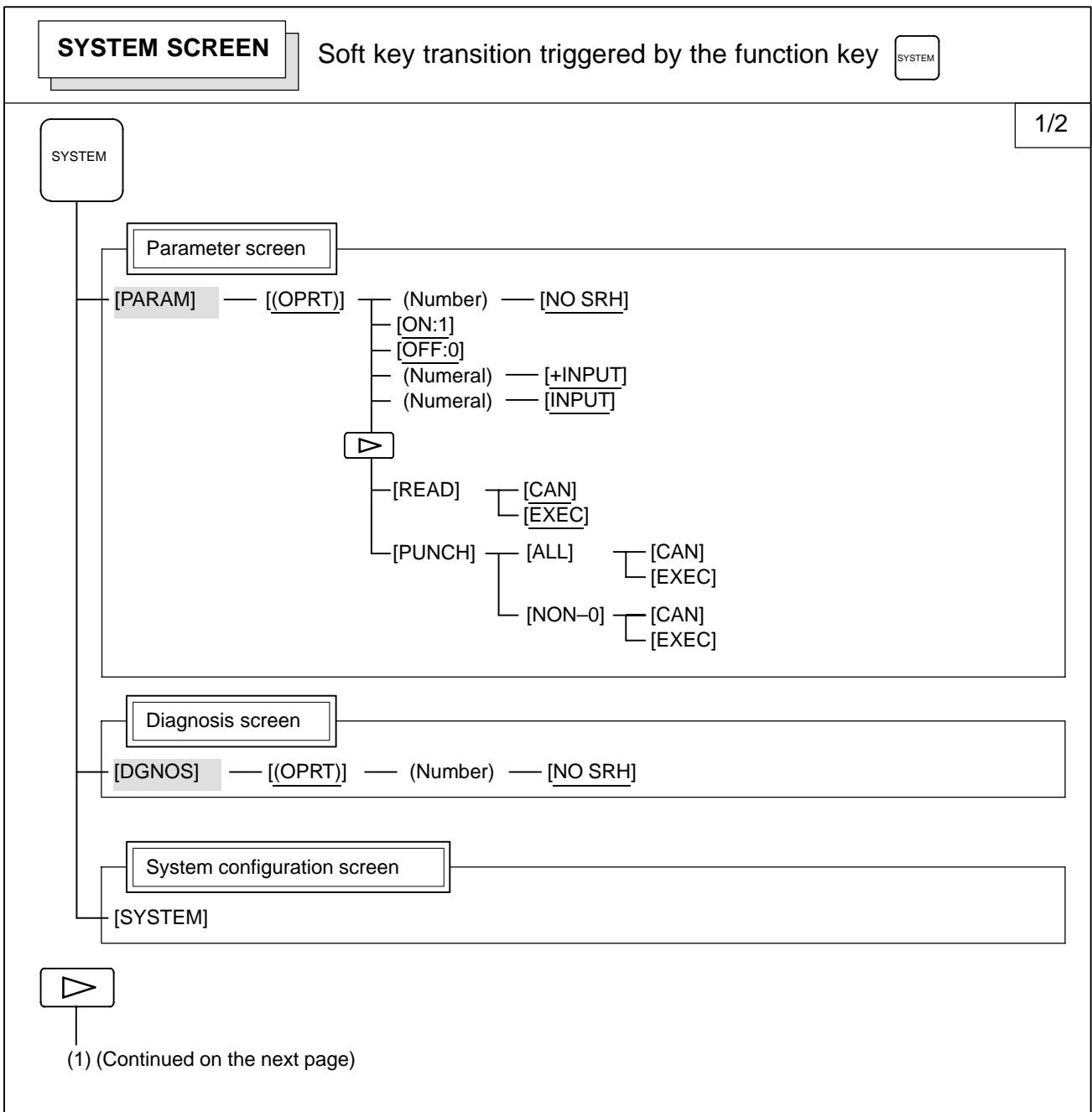

(1)

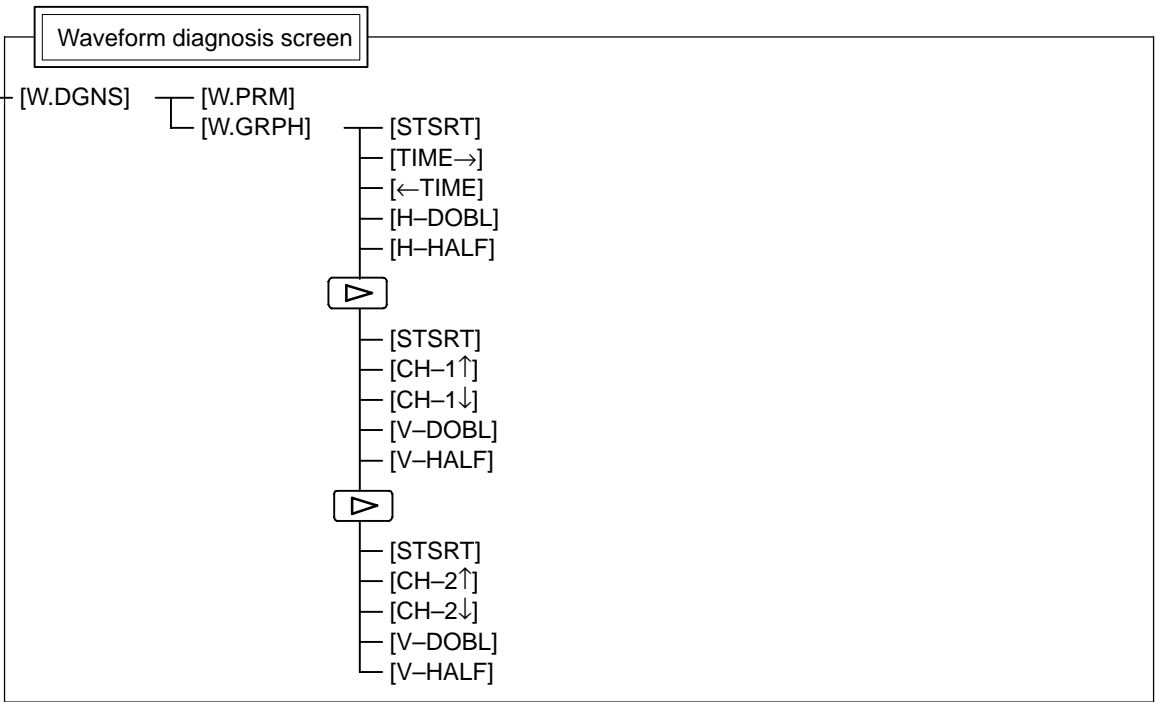
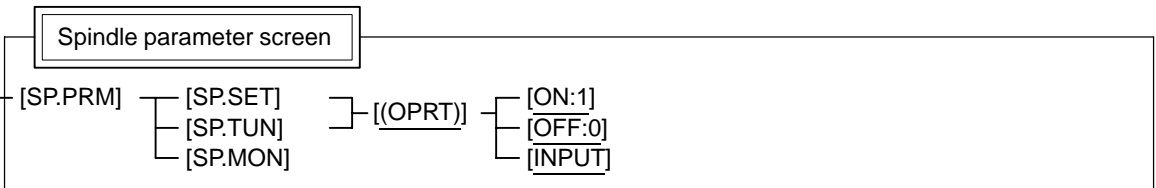
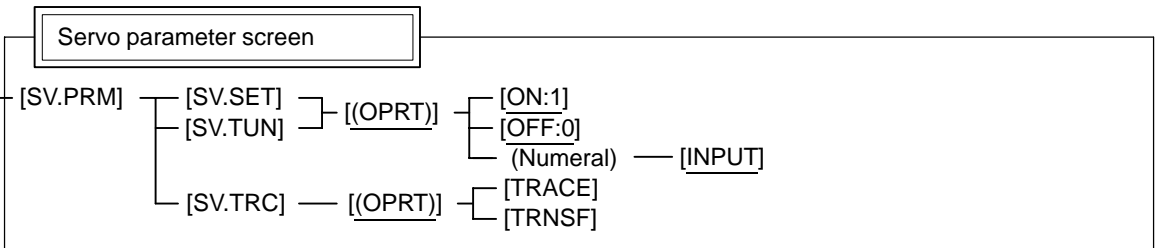
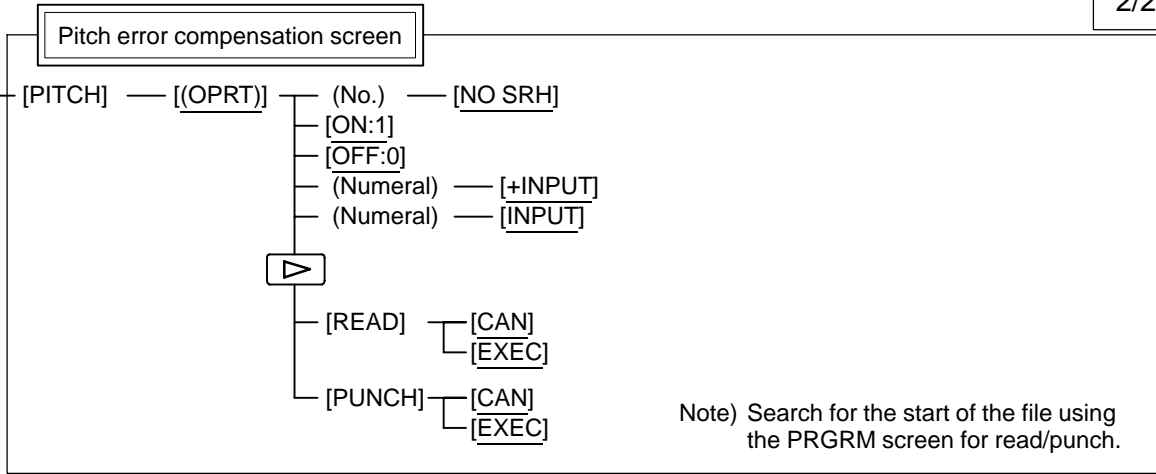

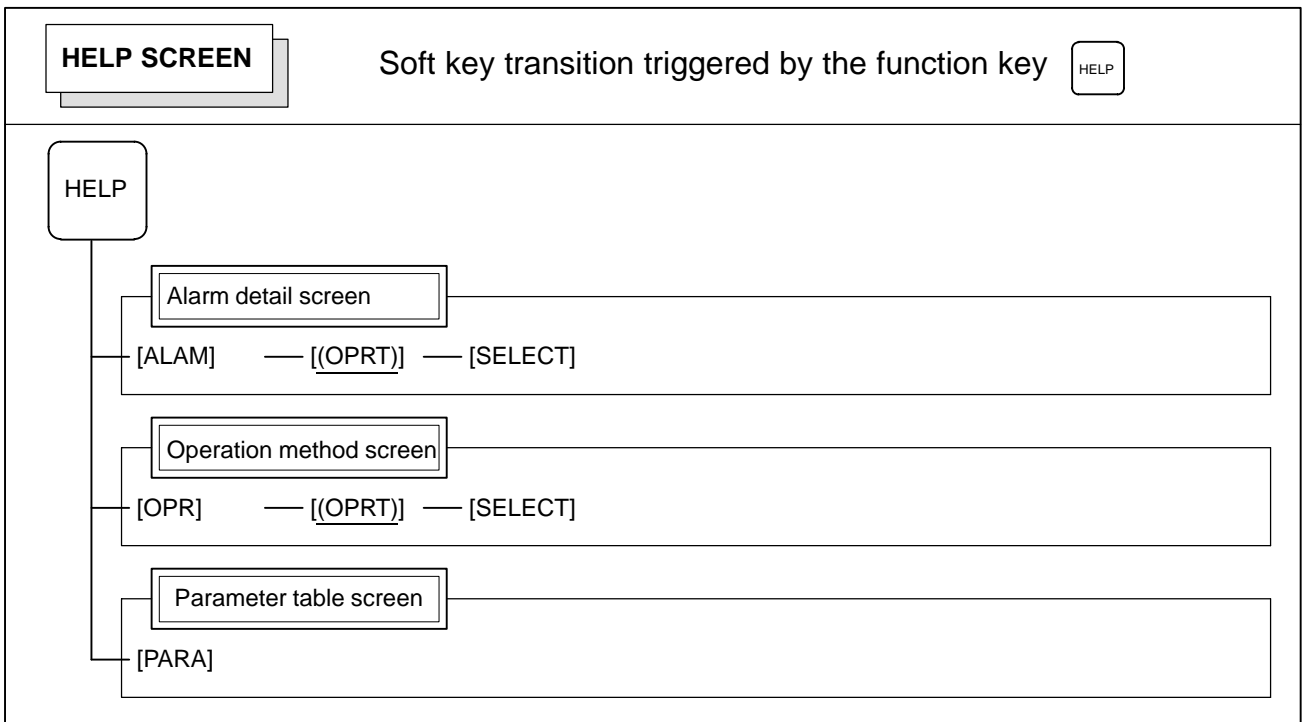
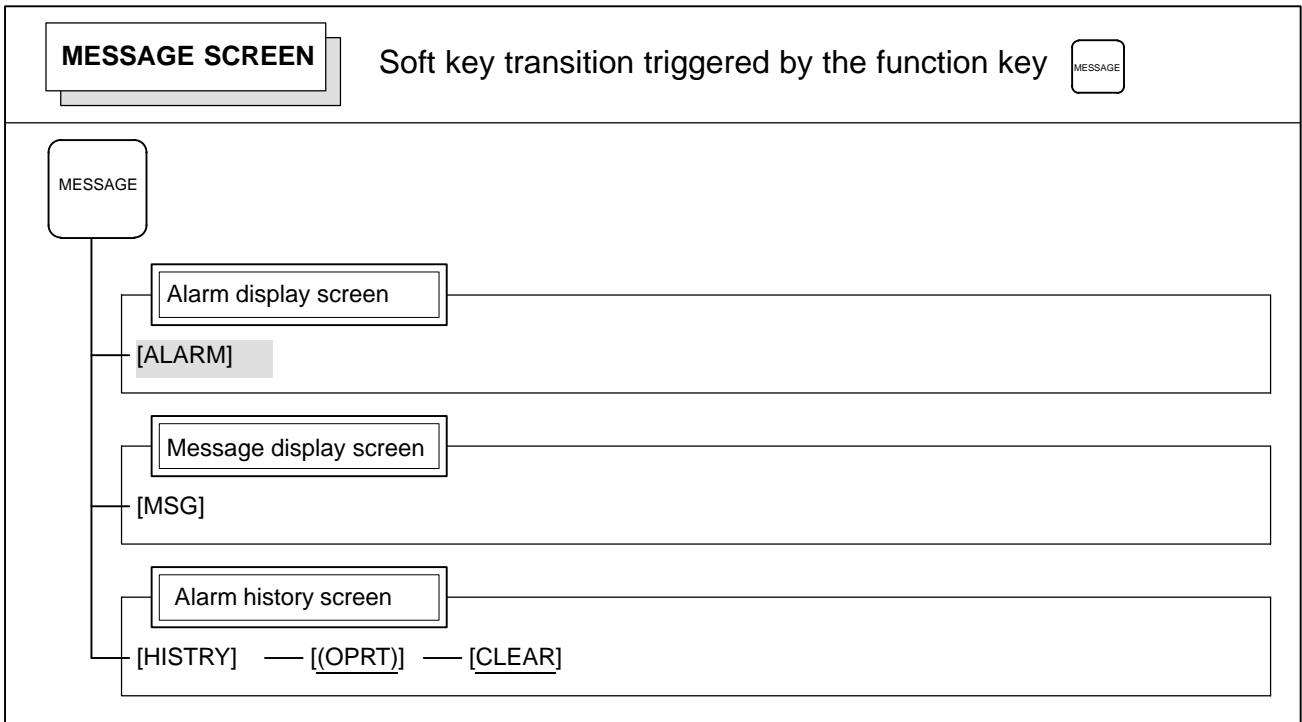

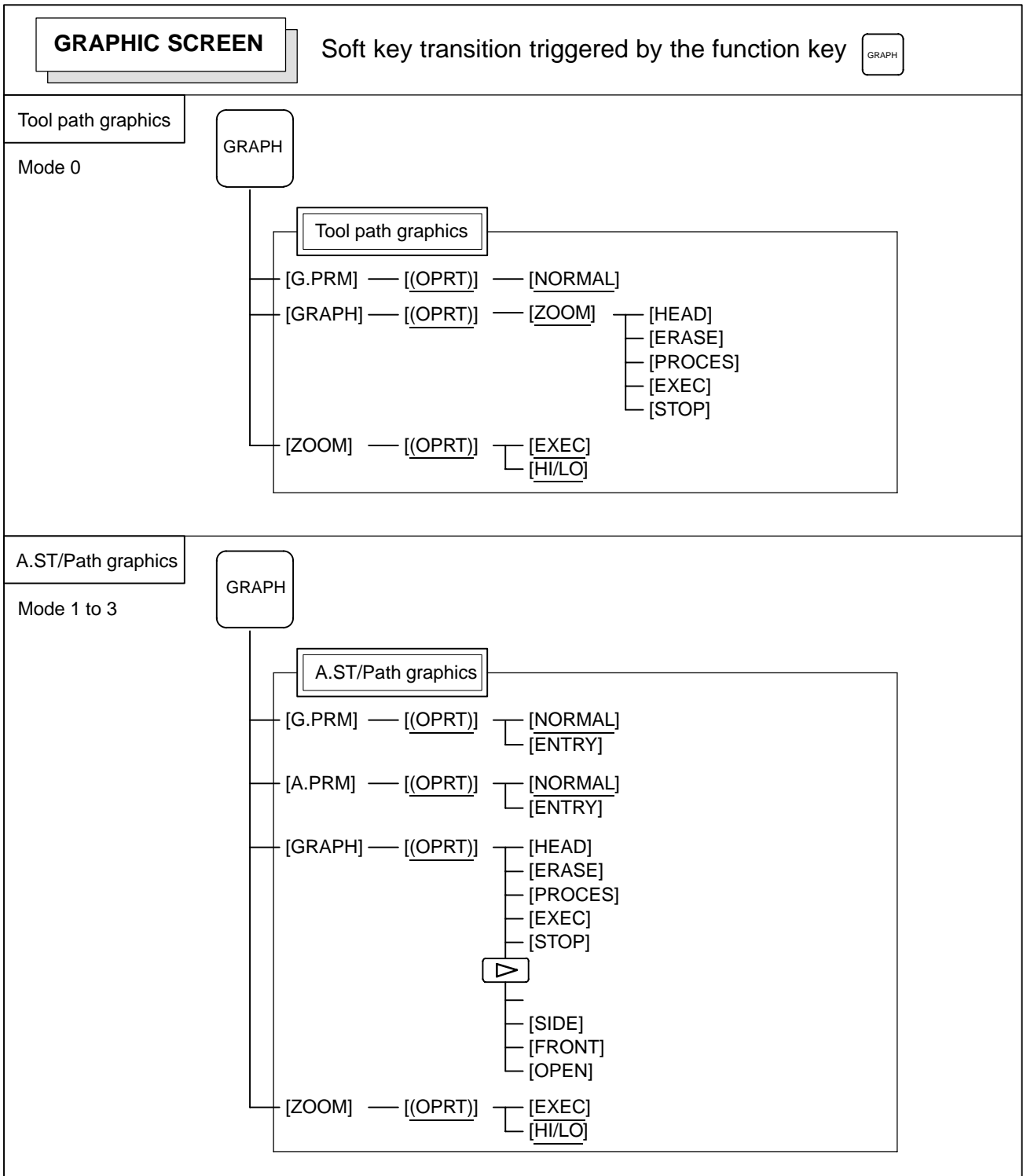

2.3.4 Key Input and Input Buffer

When an address and a numerical key are pressed, the character corresponding to that key is input once into the key input buffer. The contents of the key input buffer is displayed at the bottom of the screen. In order to indicate that it is key input data, a “>” symbol is displayed immediately in front of it. A “_” is displayed at the end of the key input data indicating the input position of the next character.

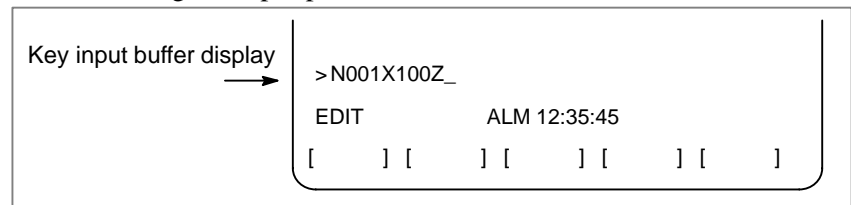



Fig. 2.3.4 Key input buffer display

To input the lower character of the keys that have two characters inscribed on them, first press the  key and then the key in question.

When the SHIFT key is pressed, “_” indicating the next character input position changes to “^”. Now lowercase characters can be entered (shift state).

When a character is input in shift status the shift status is canceled.

Furthermore, if the  key is pressed in shift status, the shift status is canceled.

It is possible to input up to 32 characters at a time in the key input buffer.

Press the  key to cancel a character or symbol input in the key input buffer.

(Example)

When the key input buffer displays

>N001X100Z_

and the cancel  key is pressed, Z is canceled and

>N001X100_

is displayed.

2.3.5 Warning Messages

After a character or number has been input from the MDI panel, a data check is executed when key or a soft key is pressed. In the case of incorrect input data or the wrong operation a flashing warning message will be displayed on the status display line.

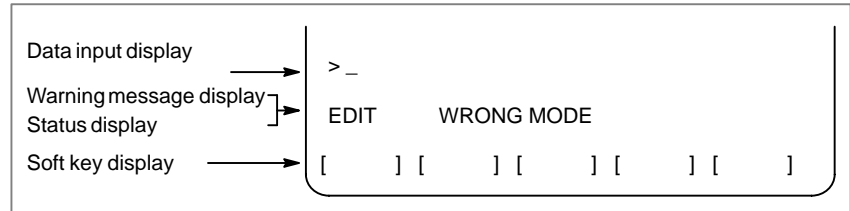

Fig. 2.3.5 Warning message display

Table 2.3.5 Warning Messages

Warning message	Content
FORMAT ERROR	The format is incorrect.
WRITE PROTECT	Key input is invalid because of data protection key or the parameter is not write enabled.
DATA IS OUT OF RANGE	The input value exceeds the permitted range.
TOO MANY DIGITS	The input value exceeds the permitted number of digits.
WRONG MODE	Parameter input is not possible in any mode other than MDI mode.
EDIT REJECTED	It is not possible to edit in the current CNC status.

2.3.6 Soft Key Configuration

There are 12 soft keys in the 10.4" LCD/MDI or 9.5" LCD/MDI panel. As illustrated below, the 5 soft keys on the right and those on the right and left edges operate in the same way as the 7.2" LCD/8.4" LCD, whereas the 5 keys on the left hand side are expansion keys dedicated to the 10.4" LCD, 9.5" LCD.

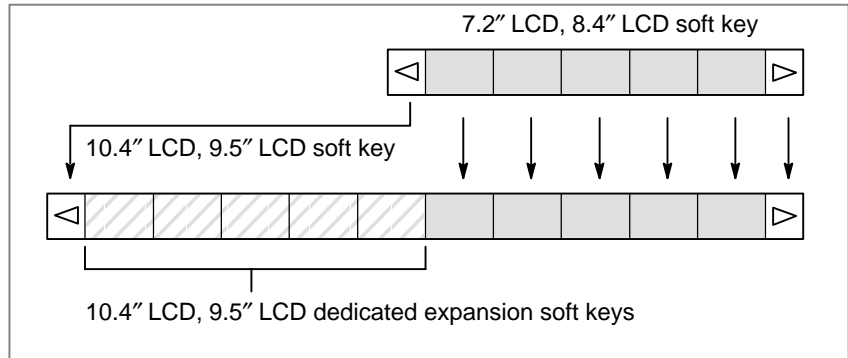
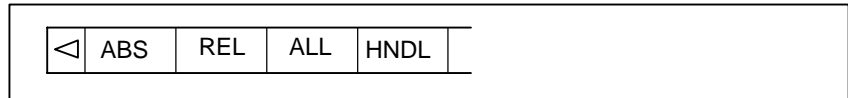

Fig. 2.3.6 LCD soft key configuration

Whenever a position display appears in the left half of the screen after a function key other than POS is pressed, the soft keys on the left half of the soft key display area are displayed as follows:



The soft key corresponding to the position display is indicated in reverse video.

This manual may refer to 10.4" and 9.5" LCD display units as 12 soft key types, and 7.2" and 8.4" LCD display unit as 7 soft key types.

2.4 EXTERNAL I/O DEVICES

External input/output devices such as FANUC Handy File etc. are available. This section outlines each device. For details on the devices, refer to the manuals listed below.

Table 2.4 External I/O device

Device name	Usage	Max. storage capacity	Reference manual
FANUC Handy File	Easy-to-use, multi function input/output device. It is designed for FA equipment and uses floppy disks.	3600m	B-61834E

The following data can be input/output to or from external input/output devices:

- 1. Programs**
- 2. Offset data**
- 3. Parameters**
- 4. Custom macro common variables**
- 5. Pitch error compensation data**

For how data is input and output, see Chapter III-8.

Parameter

Before an external input/output device can be used, parameters must be set as follows.

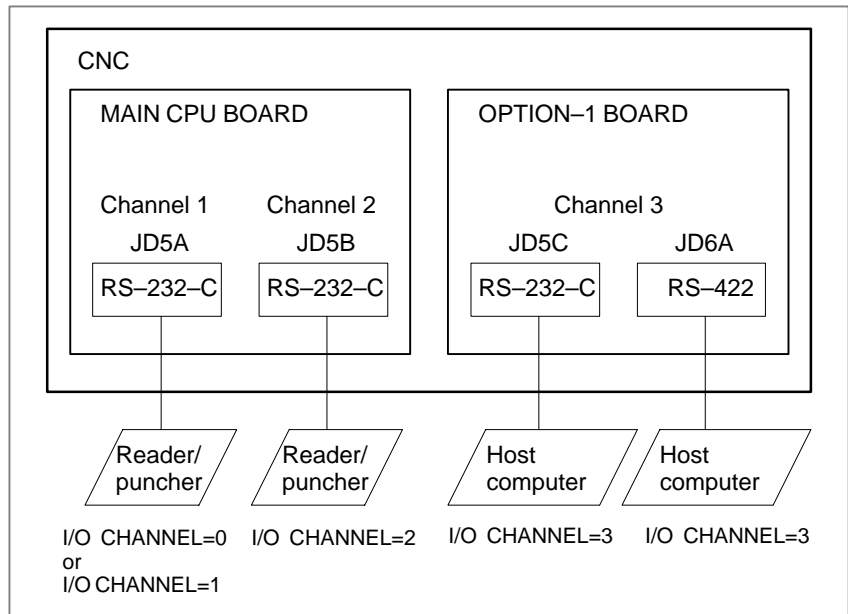

This CNC has three channels of reader/punch interfaces. The input/output device to be used is specified by setting the channel connected to that device in setting parameter I/O CHANNEL.

The specified data, such as a baud rate and the number of stop bits, of an input/output device connected to a specific channel must be set in parameters for that channel in advance.

For channel 1, two combinations of parameters to specify the input/output device data are provided.

The following shows the interrelation between the reader/punch interface parameters for the channels.

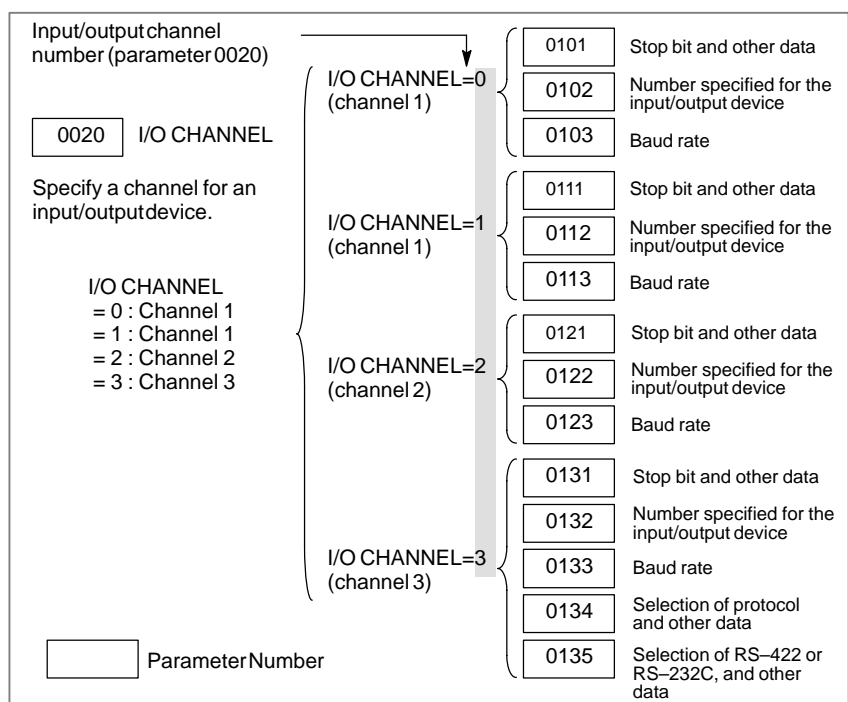

2.4.1 FANUC Handy File

The Handy File is an easy-to-use, multi function floppy disk input/output device designed for FA equipment. By operating the Handy File directly or remotely from a unit connected to the Handy File, programs can be transferred and edited.

The Handy File uses 3.5-inch floppy disks, which do not have the problems of paper tape (i.e., noisy during input/output, easily broken, and bulky).

One or more programs (up to 1.44M bytes, which is equivalent to the memory capacity of 3600-m paper tape) can be stored on one floppy disk.

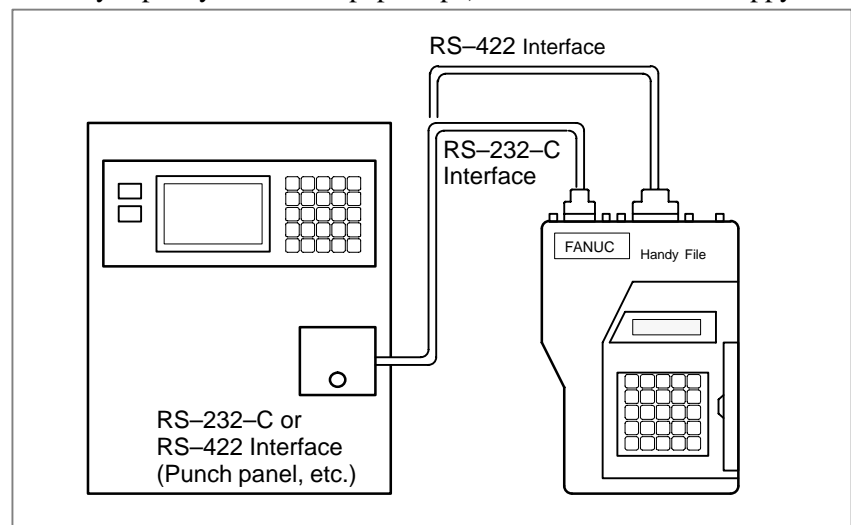

2.5 POWER ON/OFF

2.5.1 Turning on the Power

Procedure of turning on the power

- 1 Check that the appearance of the CNC machine tool is normal. (For example, check that front door and rear door are closed.)
- 2 Turn on the power according to the manual issued by the machine tool builder.
- 3 After the power is turned on, check that the position screen is displayed. An alarm screen is displayed if an alarm occurs upon power-on. If the screen shown in Section III-2.5.2 is displayed, a system failure may have occurred.

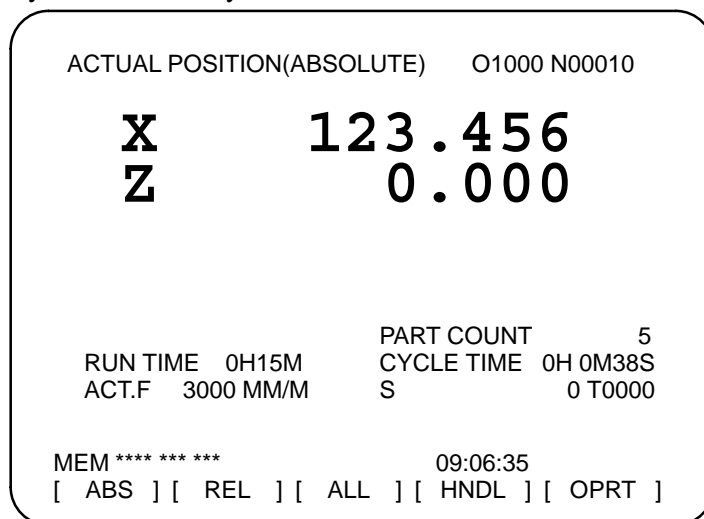

- 4 Check that the fan motor is rotating.

WARNING

Until the positional or alarm screen is displayed at the power on, do not touch them. Some keys are used for the maintenance or special operation purpose. When they are pressed, unexpected operation may be caused.

2.5.2 Screen Displayed at Power-on

If a hardware failure or installation error occurs, the system displays one of the following three types of screens then stops. Information such as the type of printed circuit board installed in each slot is indicated. This information and the LED states are useful for failure recovery.

Slot status display

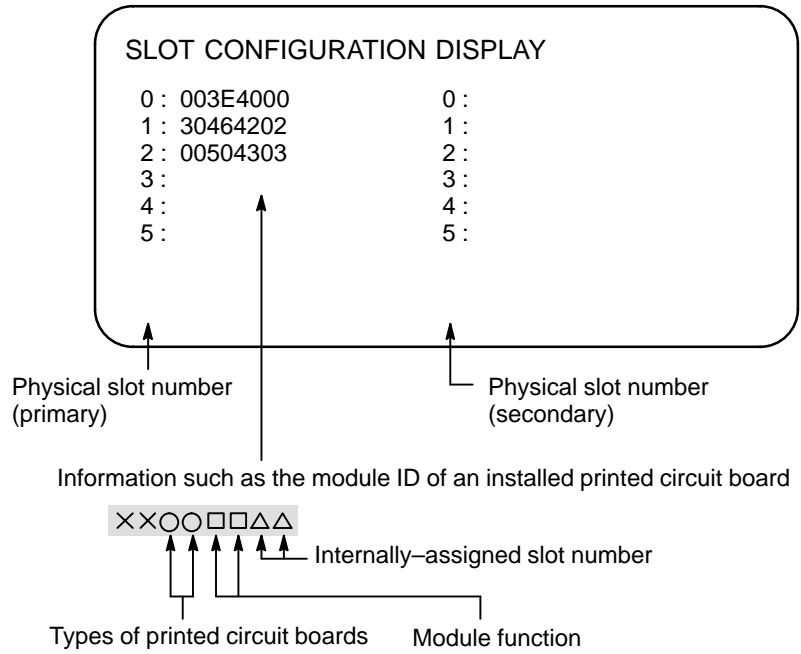

For more information about the types of printed circuit boards and module functions, refer to the maintenance manual (B-63525EN).

Screen indicating module setting status

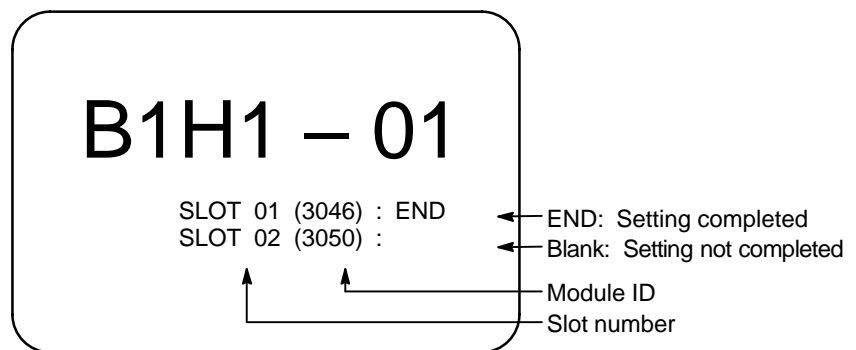

Display of software configuration

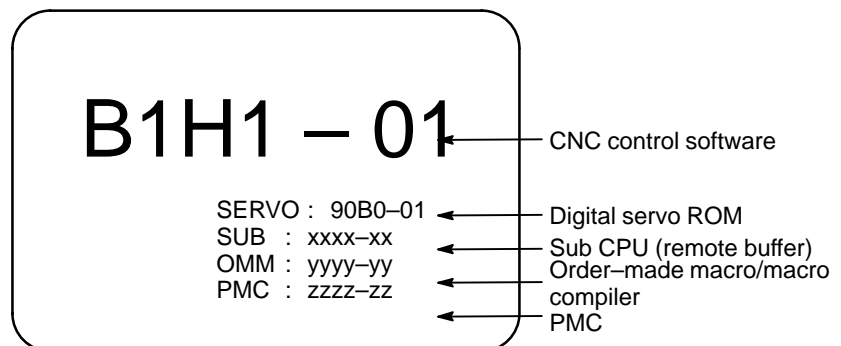

2.5.3 Power Disconnection

Procedure for Power Disconnection

- 1 Check that the LED indicating the cycle start is off on the operator's panel.
- 2 Check that all movable parts of the CNC machine tool is stopping.
- 3 If an external input/output device such as the Handy File is connected to the CNC, turn off the external input/output device.
- 4 Continue to press the POWER OFF pushbutton for about 5 seconds.
- 5 Refer to the machine tool builder's manual for turning off the power to the machine.

3

MANUAL OPERATION



MANUAL OPERATION are six kinds as follows :

3.1 Manual reference position return

3.2 Jog feed

3.3 Incremental feed

3.4 Manual handle feed

3.5 Manual absolute on and off

3.6 Manual linear / circular interpolation

3.1 MANUAL REFERENCE POSITION RETURN

The tool is returned to the reference position as follows :
 The tool is moved in the direction specified in parameter ZMI (bit 5 of No. 1006) for each axis with the reference position return switch on the machine operator’s panel. The tool moves to the deceleration point at the rapid traverse rate, then moves to the reference position at the FL speed. The rapid traverse rate and FL speed are specified in parameters (No. 1420,1421, and 1425).

Four step rapid traverse override is effective during rapid traverse.
 When the tool has returned to the reference position, the reference position return completion LED goes on. The tool generally moves along only a single axis, but can move along three axes simultaneously when specified so in parameter JAX(bit 0 of No.1002).

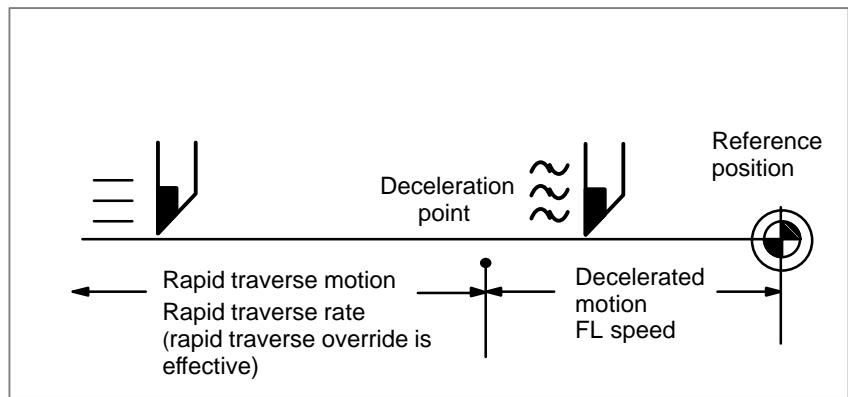

Procedure for Manual Reference Position Return

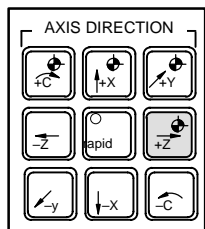
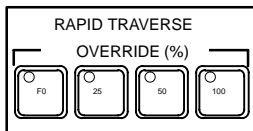
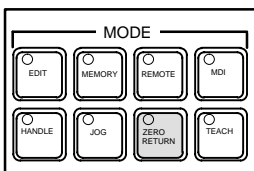

- 1 Press the reference position return switch, one of the mode selection switches.
- 2 To decrease the feedrate, press a rapid traverse override switch.
- 3 Press the feed axis and direction selection switch corresponding to the axis and direction for reference position return. Continue pressing the switch until the tool returns to the reference position. The tool can be moved along three axes simultaneously when specified so in an appropriate parameter setting. The tool moves to the deceleration point at the rapid traverse rate, then moves to the reference position at the FL speed set in a parameter.
 When the tool has returned to the reference position, the reference position return completion LED goes on.
- 4 Perform the same operations for other axes, if necessary.
 The above is an example. Refer to the appropriate manual provided by the machine tool builder for the actual operations.

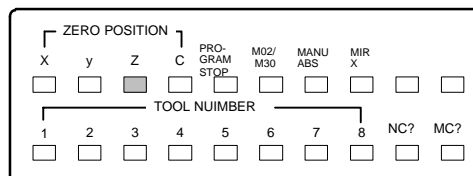

Explanation

- **Automatically setting the coordinate system**

Bit 0 (ZPR) of parameter No. 1201 is used for automatically setting the coordinate system. When ZPR is set, the coordinate system is automatically determined when manual reference position return is performed.

When α and γ are set in parameter 1250, the workpiece coordinate system is determined so that the reference point on the tool holder or the position of the tip of the reference tool is $X = \alpha$, $Z = \gamma$ when reference position return is performed. This has the same effect as specifying the following command for reference position return:

G92X α Z γ ;

However, when options of the workpiece coordinate system is selected, it is not able to use.

Restrictions

- **Moving the tool again**

Once the REFERENCE POSITION RETURN COMPLETION LED lights at the completion of reference position return, the tool does not move unless the REFERENCE POSITION RETURN switch is turned off.

- **Reference position return completion LED**

The REFERENCE POSITION RETURN COMPLETION LED is extinguished by either of the following operations:

- Moving from the reference position.
- Entering an emergency stop state.

- **The distance to return to reference position**

For the distance (Not in the deceleration condition) to return the tool to the reference position, refer to the manual issued by the machine tool builder.

3.2 JOG FEED

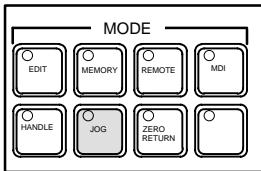

In the JOG mode, pressing a feed axis and direction selection switch on the machine operator’s panel continuously moves the tool along the selected axis in the selected direction.

The manual continuous feedrate is specified in a parameter (No.1423) The manual continuous feedrate can be adjusted with the manual continuous feedrate override dial.

Pressing the rapid traverse switch moves the tool at the rapid traverse feedrate (No.1424) regardless of the position of the JOG feedrate override dial. This function is called the manual rapid traverse.

Manual operation is allowed for one axis at a time. 3 axes can be selected at a time by parameter JAX (No.1002#0).

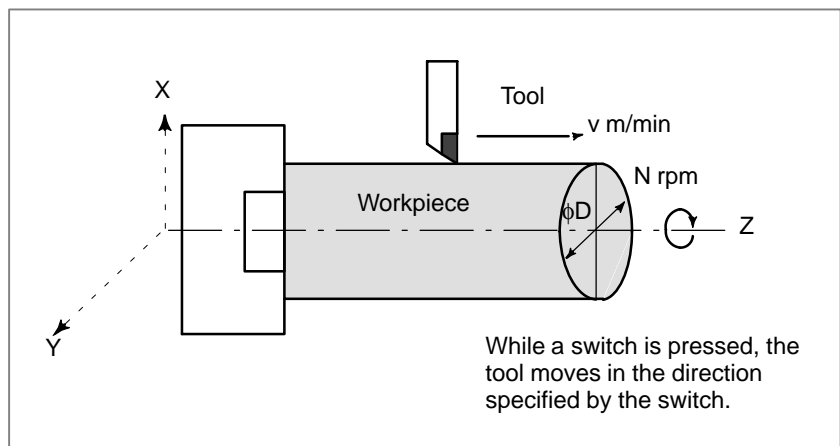

Procedure for JOG Feed

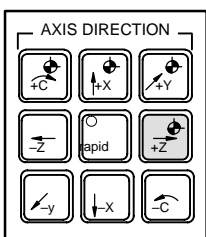

- 1 Press the manual continuous switch, one of the mode selection switches.
- 2 Press the feed axis and direction selection switch corresponding to the axis and direction the tool is to be moved. While the switch is pressed, the tool moves at the feedrate specified in a parameter (No. 1423). The tool stops when the switch is released.
- 3 The manual continuous feedrate can be adjusted with the manual continuous feedrate override dial.
- 4 Pressing the rapid traverse switch while pressing a feed axis and direction selection switch moves the tool at the rapid traverse rate while the rapid traverse switch is pressed. Rapid traverse override by the rapid traverse override switches is effective during rapid traverse.

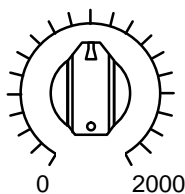

JOG FEED RATE OVERRIDE

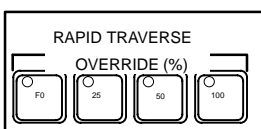

The above is an example. Refer to the appropriate manual provided by the machine tool builder for the actual operations.

Explanations

- **Manual per revolution feed**

To enable manual per revolution feed, set bit 4 (JRV) of parameter No. 1402 to 1.

During manual per revolution feed, the tool is jogged at the following feedrate:

Feed distance per rotation of the spindle (mm/rev) (specified with parameter No. 1423) x JOG feedrate override x actual spindle speed (rev/min).

Restrictions

- **Acceleration/deceleration for rapid traverse**

Feedrate, time constant and method of automatic acceleration/deceleration for manual rapid traverse are the same as G00 in programmed command.

- **Change of modes**

Changing the mode to the JOG feed mode while pressing a feed axis and direction selection switch does not enable JOG feed. To enable JOG feed, enter the JOG feed mode first, then press a feed axis and direction selection switch.

- **Rapid traverse prior to reference position return**

If reference position return is not performed after power-on, pushing RAPID TRAVERSE button does not actuate the rapid traverse but the remains at the manual continuous feedrate. This function can be disabled by setting parameter RPD (No.1401#01).

3.3 INCREMENTAL FEED

In the incremental (INC) mode, pressing a feed axis and direction selection switch on the machine operator's panel moves the tool one step along the selected axis in the selected direction. The minimum distance the tool is moved is the least input increment. Each step can be 10, 100, or 1000 times the least input increment.

This mode is effective when a manual pulse generator is not connected.

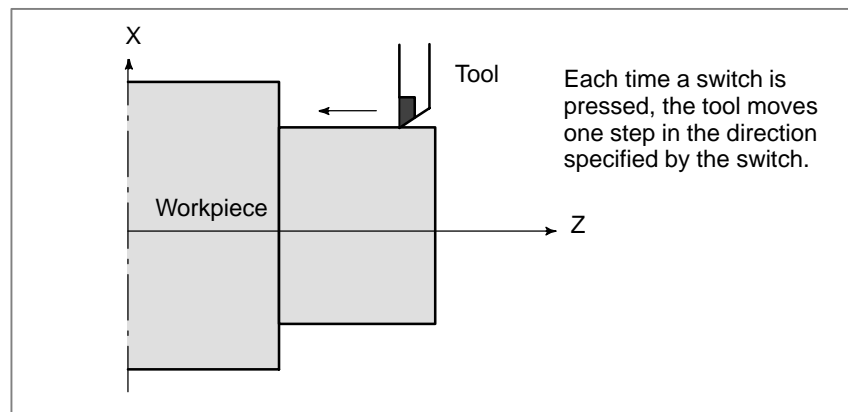

Procedure for Incremental Feed

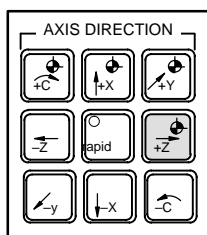
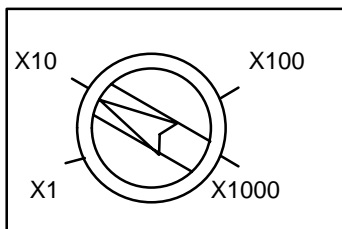

- 1 Press the INC switch, one of the mode selection switches.
- 2 Select the distance to be moved for each step with the magnification dial.
- 3 Press the feed axis and direction selection switch corresponding to the axis and direction the tool is to be moved. Each time a switch is pressed, the tool moves one step. The feedrate is the same as the jog feedrate.
- 4 Pressing the rapid traverse switch while pressing a feed axis and direction selection switch moves the tool at the rapid traverse rate. Rapid traverse override by the rapid traverse override switch is effective during rapid traverse.

The above is an example. Refer to the appropriate manual provided by the machine tool builder for the actual operations.

Explanation

- **Travel distance specified with a diameter**

The distance the tool travels along the X-axis can be specified with a diameter.

3.4 MANUAL HANDLE FEED

In the handle mode, the tool can be minutely moved by rotating the manual pulse generator on the machine operator's panel. Select the axis along which the tool is to be moved with the handle feed axis selection switches.

The minimum distance the tool is moved when the manual pulse generator is rotated by one graduation is equal to the least input increment. Or the distance the tool is moved when the manual pulse generator is rotated by one graduation can be magnified by 10 times or by one of the two magnifications specified by parameters (No. 7113 and 7114).

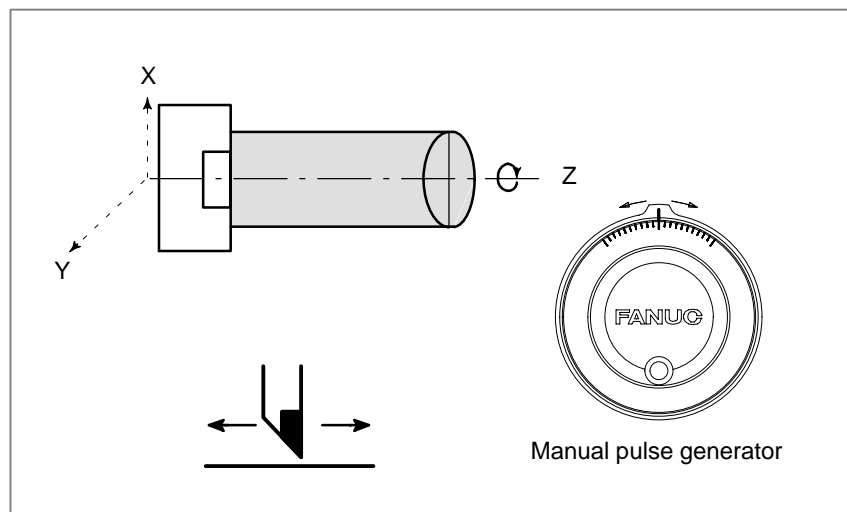

Procedure for Manual Handle Feed

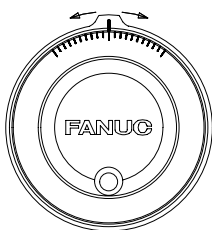
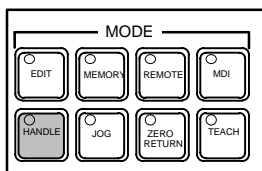

Manual pulse generator

- 1 Press the HANDLE switch, one of the mode selection switches.
- 2 Select the axis along which the tool is to be moved by pressing a handle feed axis selection switch.
- 3 Select the magnification for the distance the tool is to be moved by pressing a handle feed magnification switch. The minimum distance the tool is moved when the manual pulse generator is rotated by one graduation is equal to the least input increment.
- 4 Move the tool along the selected axis by rotating the handle. Rotating the handle 360 degrees moves the tool the distance equivalent to 100 graduations.

The above is an example. Refer to the appropriate manual provided by the machine tool builder for the actual operations.

Explanation

- **Availability of manual pulse generator in Jog mode (JHD)**

Parameter JHD (bit 0 of No. 7100) enables or disables the manual pulse generator in the JOG mode.
When the parameter JHD(bit 0 of No. 7100) is set 1, both manual handle feed and incremental feed are enabled.
- **Availability of manual pulse generator in TEACH IN JOG mode (THD)**

Parameter THD (bit 1 of No. 7100) enables or disables the manual pulse generator in the TEACH IN JOG mode.
- **A command to the MPG exceeding rapid traverse rate (HPF)**

Parameter HPF (bit 4 of No. 7100) or (No. 7117) specifies as follows:

 - Parameter HPF (bit 4 of No. 7100)

Set value 0 : The feedrate is clamped at the rapid traverse rate and generated pulses exceeding the rapid traverse rate are ignored. (The distance the tool is moved may not match the graduations on the manual pulse generator.)

Set value 1 : The feedrate is clamped at the rapid traverse rate and generated pulses exceeding the rapid traverse rate are not ignored but accumulated in the CNC.
(No longer rotating the handle does not immediately stop the tool. The tool is moved by the pulses accumulated in the CNC before it stops.)
 - Parameter HPF (No. 7177) (It is available when parameter HPF is 0.)

Set value 0 : The feedrate is clamped at the rapid traverse rate and generated pulses exceeding the rapid traverse rate are ignored. (The distance the tool is moved may not match the graduations on the manual pulse generator.)

Other than 0 : The feedrate is clamped at the rapid traverse rate and generated pulses exceeding the rapid traverse rate are not ignored but accumulated in the CNC until the limit specified in parameter No. 7117 is reached.
(No longer rotating the handle does not immediately stop the tool. The tool is moved by the pulses accumulated in the CNC before it stops.)
- **Movement direction of an axis to the rotation of MPG (HNGx)**

Parameter HNGx (bit 0 of No. 7102) switches the direction of MPG in which the tool moves along an axis, corresponding to the direction in which the handle of the manual pulse generator is rotated.

Restrictions

- **Number of MPGs**

Up to three manual pulse generators can be connected, one for each axis. The three manual pulse generators can be simultaneously operated.

WARNING

Rotating the handle quickly with a large magnification such as x100 moves the tool too fast. The feedrate is clamped at the rapid traverse feedrate.

NOTE

Rotate the manual pulse generator at a rate of five rotations per second or lower. If the manual pulse generator is rotated at a rate higher than five rotations per second, the tool may not stop immediately after the handle is no longer rotated or the distance the tool moves may not match the graduations on the manual pulse generator.

3.5 MANUAL ABSOLUTE ON AND OFF

Whether the distance the tool is moved by manual operation is added to the coordinates can be selected by turning the manual absolute switch on or off on the machine operator's panel. When the switch is turned on, the distance the tool is moved by manual operation is added to the coordinates. When the switch is turned off, the distance the tool is moved by manual operation is not added to the coordinates.

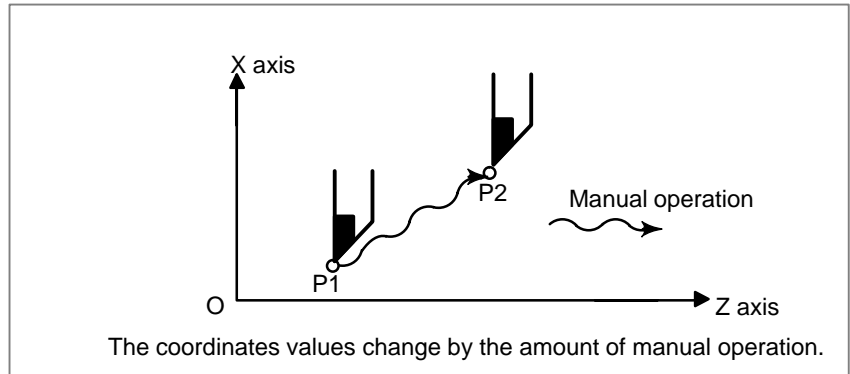

Fig. 3.5 (a) Coordinates with the switch ON

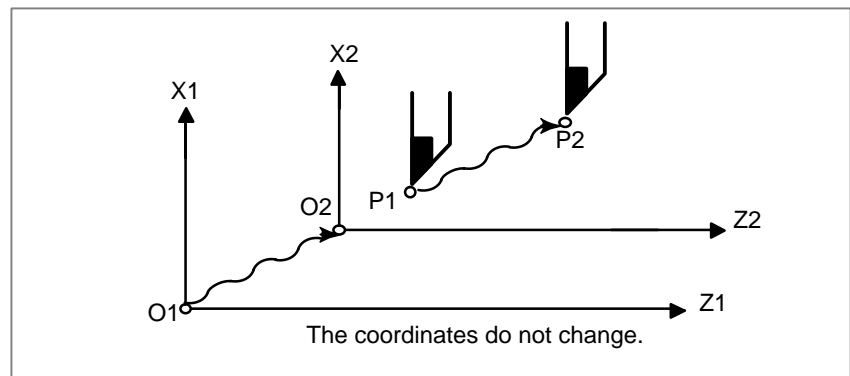

Fig. 3.5 (b) Coordinates with the switch OFF

Explanation

The following describes the relation between manual operation and coordinates when the manual absolute switch is turned on or off, using a program example.

```

G01G90 X100.0Z100.0F010 ; (1)
      X200.0Z150.0 ; (2)
      X300.0Z200.0 ; (3)
    
```

The subsequent figures use the following notation:

- Movement of the tool when the switch is on
- - -→ Movement of the tool when the switch is off

The coordinates after manual operation include the distance the tool is moved by the manual operation. When the switch is off, therefore, subtract the distance the tool is moved by the manual operation.

● **Manual operation after the end of block**

Coordinates when block (2) has been executed after manual operation (X-axis +20.0, Z-axis +100.0) at the end of movement of block (1).

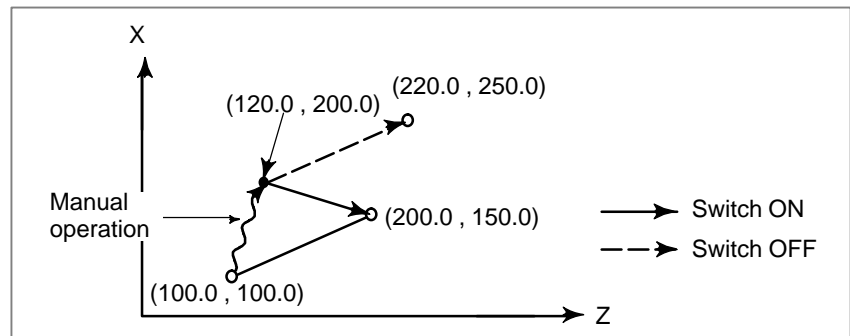

● **Manual operation after a feed hold**

Coordinates when the feed hold button is pressed while block (2) is being executed, manual operation (X-axis + 75.0) is performed, and the cycle start button is pressed and released

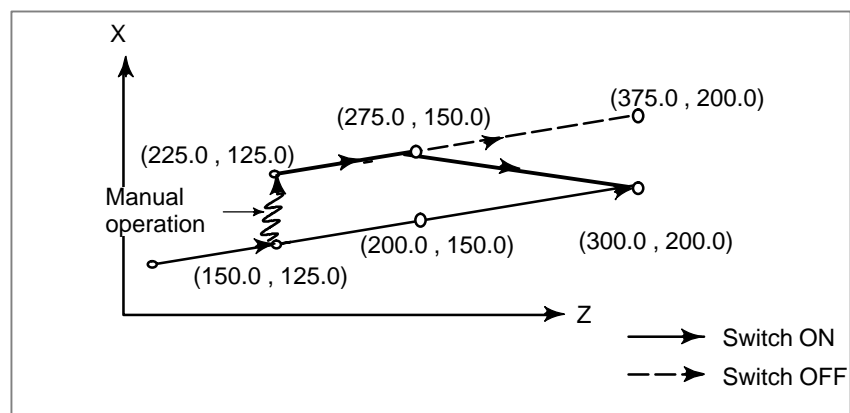

- **When reset after a manual operation following a feed hold**

Coordinates when the feed hold button is pressed while block (2) is being executed, manual operation (Y-axis +75.0) is performed, the control unit is reset with the RESET button, and block (2) is read again

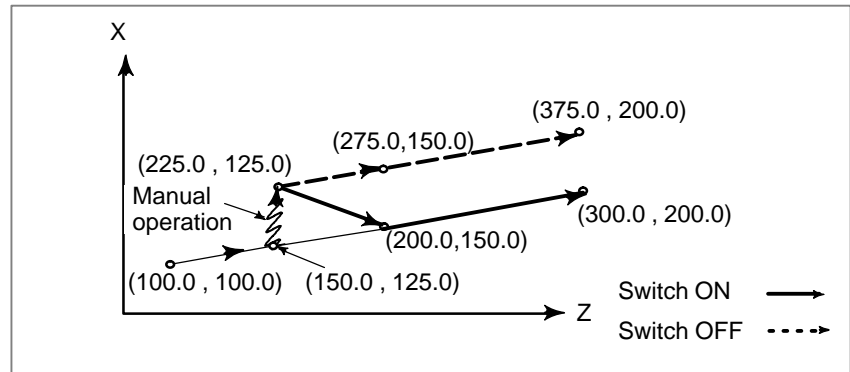

- **When a movement command in the next block is only one axis**

When there is only one axis in the following command, only the commanded axis returns.

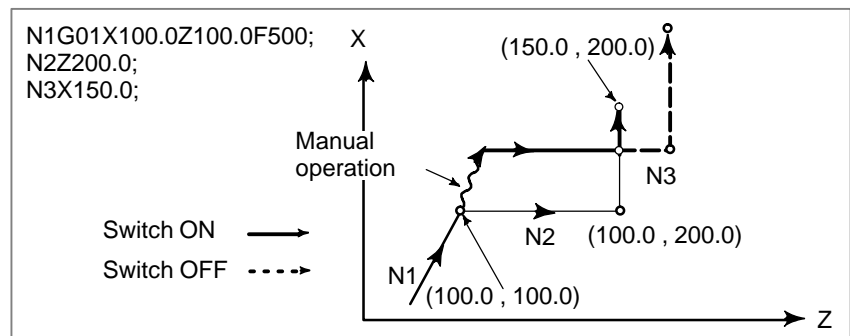

- **When the next move block is an incremental**
- **Manual operation during tool nose radius compensation**

When the following commands are incremental commands, operation is the same as when the switch is OFF.

When the switch is OFF

After manual operation is performed with the switch OFF during tool nose radius compensation, automatic operation is restarted then the tool moves parallel to the movement that would have been performed if manual movement had not been performed. The amount of separation equals to the amount that was performed manually.

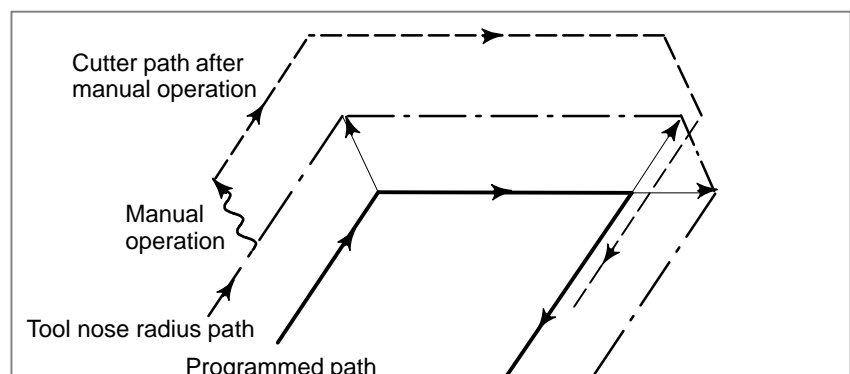

When the switch is ON during tool nose radius compensation

Operation of the machine upon return to automatic operation after manual intervention with the switch is ON during execution with an absolute command program in the tool nose radius compensation mode will be described. The vector created from the remaining part of the current block and the beginning of the next block is shifted in parallel. A new vector is created based on the next block, the block following the next block and the amount of manual movement. This also applies when manual operation is performed during cornering.

Manual operation performed in other than cornering

Assume that the feed hold was applied at point P_H while moving from P_A to P_B of programmed path P_A , P_B , and P_C and that the tool was manually moved to $P_{H'}$. The block end point P_B moves to the point $P_{B'}$ by the amount of manual movement, and vectors V_{B1} and V_{B2} at P_B also move to $V_{B1'}$ and $V_{B2'}$. Vectors V_{C1} and V_{C2} between the next two blocks $P_B - P_C$ and $P_C - P_D$ are discarded and new vectors $V_{C1'}$ and $V_{C2'}$ ($V_{C2'} = V_{C2}$ in this example) are produced from the relation between $P_{B'} - P_C$ and $P_C - P_D$. However, since $V_{B2'}$ is not a newly calculated vector, correct offset is not performed at block $P_{B'} - P_C$. Offset is correctly performed after P_C .

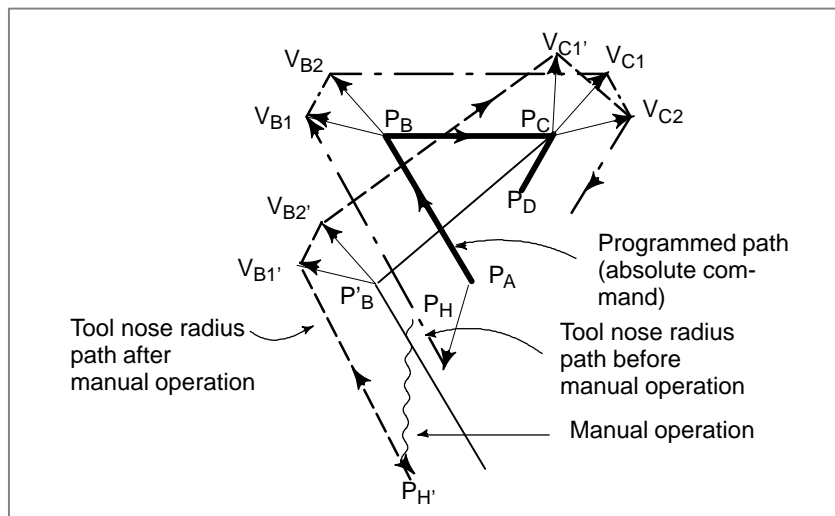

Manual operation during cornering

This is an example when manual operation is performed during cornering. $V_{A2'}$, $V_{B1'}$, and $V_{B2'}$ are vectors moved in parallel with V_{A2} , V_{B1} and V_{B2} by the amount of manual movement. The new vectors are calculated from V_{C1} and V_{C2} . Then correct tool nose radius compensation is performed for the blocks following P_C .

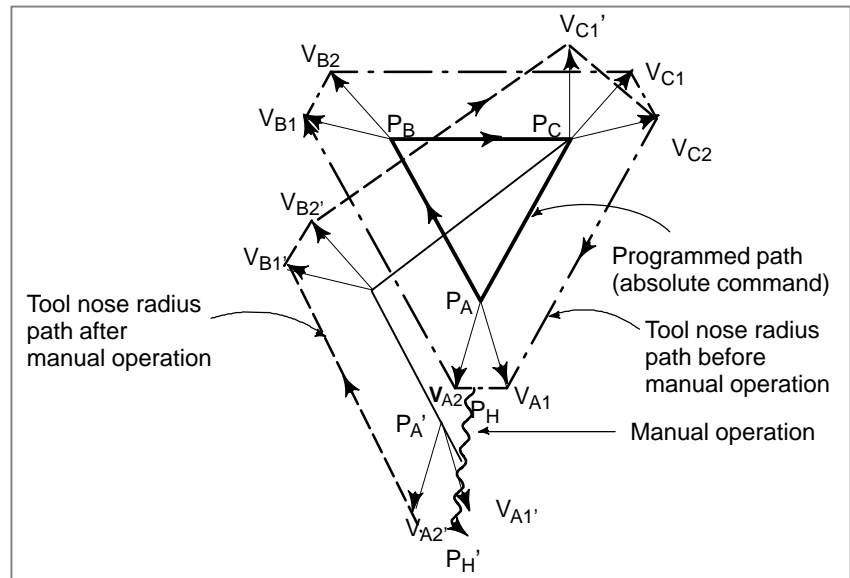

Manual operation after single block stop

Manual operation was performed when execution of a block was terminated by single block stop.

Vectors V_{B1} and V_{B2} are shifted by the amount of manual operation. Sub-sequent processing is the same as a described above. An MDI operation can also be interveneted as well as manual operation. The movement is the same as that by manual operation.

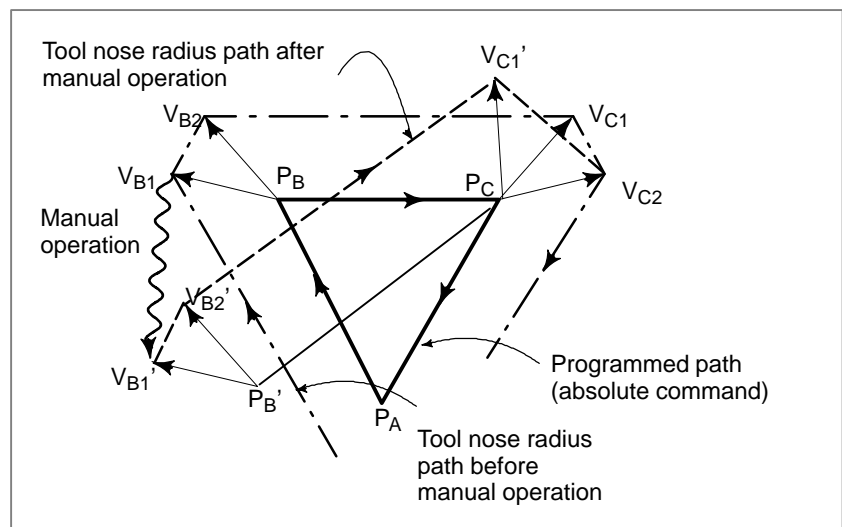

3.6 MANUAL LINEAR/CIRCULAR INTERPOLATION

In manual handle feed or jog feed, the following types of feed operations are enabled in addition to the conventional feed operation along a specified single axis (X-axis, Y-axis, Z-axis, and so forth) based on simultaneous 1-axis control:

- Feed along a tilted straight line in the XY plane (linear feed) based on simultaneous 2-axis control
- Feed along a circle in the XY plane (circular feed) based on simultaneous 2-axis control

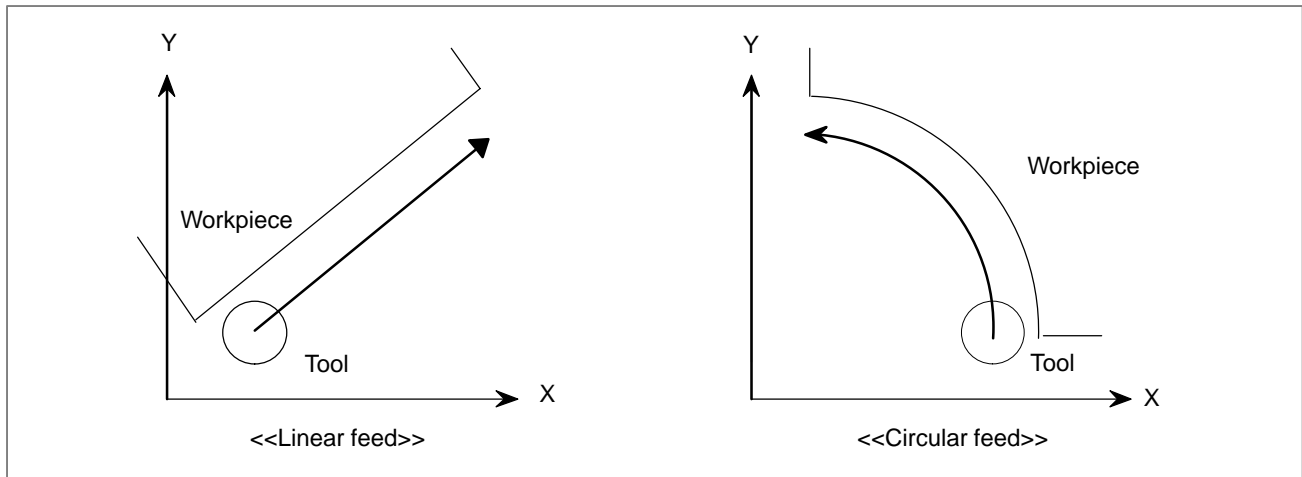

NOTE

The X-axis and Y-axis must be the first controlled axis and second controlled axis, respectively.

Procedure for Manual Linear/Circular Interpolation

Procedure

- 1 To perform manual handle feed, select manual handle feed mode. To perform jog feed, select jog feed mode.
- 2 To perform manual handle feed, select a feed axis (for simultaneous 1-axis feed along the X-axis, Y-axis, or Z-axis, or for simultaneous linear or circular 2-axis feed along a specified straight line or circle in the XY plane) subject to manual handle feed operation. Use the handle feed axis select switch for this selection.
To perform jog feed, select a feed axis and direction with the feed axis direction select switch. While a feed axis and its direction are specified, the tool moves in the specified axis direction or along a straight line or circle at the jog feedrate specified in parameter No. 1423.

- 3 For manual handle feed

The tool is moved along a specified axis by turning the respective manual handle. The feedrate depends on the speed at which the manual handle is turned. A distance to be traveled by the tool when the manual handle is turned by one pulse can be selected using the manual handle feed travel distance magnification switch.

For jog feed

The feedrate can be overridden using the manual feedrate override dial.

The procedure above is just an example. For actual operations, refer to the relevant manual provided by the machine tool builder.

Explanations

- **Definition of a straight line/circle**

For feed along an axis, no straight line/circle definition is required. For linear feed or circular feed, a straight line or circle must be defined beforehand. (For circular feed, for example, data such as a radius and the center of a circle must be set.) For details, refer to the relevant manual provided by the machine tool builder.

- **Manual handle feed**

In manual handle feed, the tool can be moved along a specified axis (X-axis, Y-axis, Z-axis, ..., or the 8th axis), or can be moved along a tilted straight line (linear feed) or a circle (circular feed).

(1) Feed along a specified axis (simultaneous 1-axis control)

By turning a manual handle, the tool can be moved along the desired axis (such as X-axis, Y-axis, and Z-axis) on a simultaneous 1-axis control basis. (This mode of feed is the conventional type of manual handle feed.)

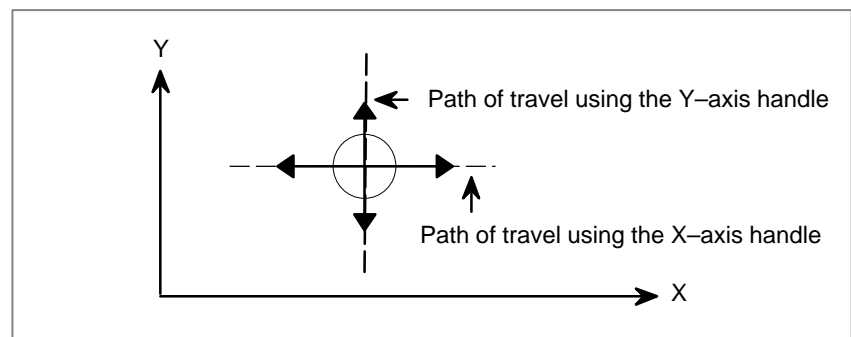

Feed along a specified axis

(2) Linear feed (simultaneous 2-axis control)

By turning a manual handle, the tool can be moved along the straight line parallel to a specified straight line on a simultaneous 2-axis control basis. This manual handle is referred to as the guidance handle. Moreover, by turning another manual handle, the tool can be moved at right angles to a specified straight line on a simultaneous 2-axis control basis. This manual handle is referred to as the approach handle. When the guidance handle or approach handle is turned clockwise or counterclockwise, the tool travels forward or backward along the respective path.

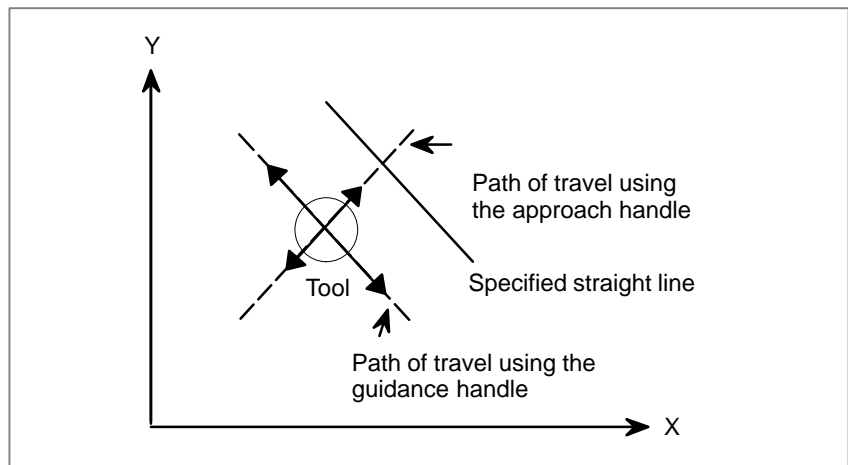
**Linear feed**

(3) Circular feed (simultaneous 2-axis control)

By turning a manual handle, the tool can be moved from the current position along the concentric circle that has the same center as a specified circle on a simultaneous 2-axis control basis. This manual handle is referred to as the guidance handle. Moreover, by turning another manual handle, the tool can be moved along the normal to a specified circle on a simultaneous 2-axis control basis. This manual handle is referred to as the approach handle. When the guidance handle or approach handle is turned clockwise or counterclockwise, the tool travels forward or backward along the respective path.

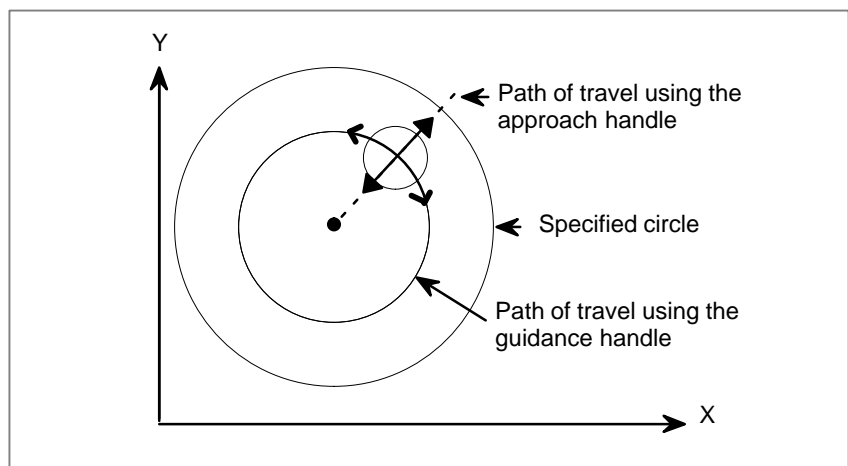
**Circular feed**

- **Feedrate for manual handle feed**

Feedrate

The feedrate depends on the speed at which a manual handle is turned. A distance to be traveled by the tool (along a tangent in the case of linear or circular feed) when a manual handle is turned by one pulse can be selected using the manual handle feed travel distance magnification switch.
- **Manual handle selection**

The FS16/18 has three manual pulse generator interfaces to allow up to three manual handles to be connected. For information about how to use the manual handles connected to the interfaces (whether to use each manual handle as a handle for feed along an axis, as a guidance handle, or as an approach handle), refer to the relevant manual provided by the machine tool builder.
- **Direction of movement using manual handles**

The user can specify the direction of the tool moved along a straight line or circle (for example, whether to make a clockwise or counterclockwise movement along a circle) when the guidance handle or approach handle is turned clockwise or counterclockwise. For details, refer to the relevant manual provided by the machine tool builder.
- **Jog feed (JOG)**

In jog feed, the tool can be moved along a specified axis (X-axis, Z-axis, ..., or the 8th axis), or can be moved along a tilted straight line (linear feed) or a circle (circular feed).

 - (1) Feed along a specified axis (simultaneous 1-axis control)

While a feed axis and its direction are specified with the feed axis direction select switch, the tool moves in the specified axis direction at the feedrate specified in parameter No. 1423. The feedrate can be overridden using the manual feedrate override dial.
 - (2) Linear feed (simultaneous 2-axis control)

By defining a straight line beforehand, the tool can be moved as follows:

 - While a feed axis and its direction are selected using the feed axis direction select switch, the tool moves along a straight line parallel to the specified straight line on a simultaneous 2-axis control basis.
 - While a feed axis and its direction are selected using the feed axis direction select switch, the tool moves at right angles to the specified straight line on a simultaneous 2-axis control basis.

The feedrate in the tangential direction is specified in parameter No. 1410. The feedrate can be overridden using the manual feedrate override dial.
 - (3) Circular feed (simultaneous 2-axis control)

By defining a circle beforehand, the tool can be moved as follows:

 - While a feed axis and its direction are selected using the feed axis direction select switch, the tool moves from the current position along the concentric circle that has the same center as the specified circle.
 - While a feed axis and its direction are selected using the feed axis direction select switch, the tool moves along the normal to the specified circle.

The feedrate in the tangential direction is specified in parameter No. 1410. The feedrate can be overridden using the manual feedrate override dial.

- **Manual handle feed in JOG mode**

Even in JOG mode, manual handle feed can be enabled using bit 0 (JHD) of parameter No. 7100. In this case, however, manual handle feed is enabled only when the tool is not moved along any axis by jog feed.

Limitations

- **Mirror image**

Never use the mirror image function when performing manual operation. (Perform manual operation when the mirror image switch is off, and mirror image setting is off.)

3.7 MANUAL NUMERIC COMMAND

The manual numeric command function allows data programmed through the MDI to be executed in jog mode. Whenever the system is ready for jog feed, a manual numeric command can be executed. The following eight functions are supported:

- (1) Positioning (G00)
- (2) Linear interpolation (G01)
- (3) Automatic reference position return (G28)
- (4) 2nd/3rd/4th reference position return (G30)
- (5) M codes (miscellaneous functions)
- (6) S codes (spindle functions)
- (7) B codes (second auxiliary functions)

By setting the following parameters, the commands for axial motion and the M, S, T, and B functions can be disabled:

- | | | |
|---|---|---------------------------------------|
| (1) Positioning (G00) | } | Bit 0 (JAXx) of
parameter No. 7010 |
| (2) Linear interpolation (G01): | | |
| (3) Automatic reference position
return (G28): | | |
| (4) 2nd/3rd/4th reference position
return (G30): | | |
| (5) M codes (miscellaneous functions): | | Bit 0 (JMF) of parameter No. 7002 |
| (6) S codes (spindle functions): | | Bit 1 (JSF) of parameter No. 7002 |
| (7) B codes (second auxiliary functions): | | Bit 3 (JBF) of parameter No. 7002 |

Procedure

Manual numeric command

Procedure

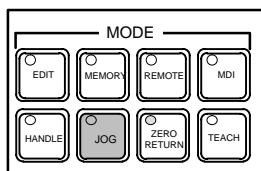

- 1 Press the jog switch (one of the mode selection switches).
- 2 Press function key  .
- 3 Press soft key **[JOG]** on the screen. The following manual numeric command screen is displayed.

Example 1: When the maximum number of controlled axes is six

PROGRAM (JOG)		O0010 N0020	
G00 P	(ABSOLUTE)	(DISTANCE TO GO)	
X	X 0.000	X 0.000	
Y	Y 0.000	Y 0.000	
Z	Z 0.000	Z 0.000	
U	U 0.000	U 0.000	
V	V 0.000	V 0.000	
W	W 0.000	W 0.000	
M			
S			
T			
B			
>_			
JOG **** * * *		00 : 00 : 00	
[PRGRM]	[JOG]	[CURRNT]	[NEXT] [(OPRT)]

Example 2: When the maximum number of controlled axes is 7 or 8

PROGRAM (JOG)		O0010 N0020	
G00 P	(ABSOLUTE)	(DISTANCE TO GO)	
X	X 0.000	X 0.000	
Y	Y 0.000	Y 0.000	
Z	Z 0.000	Z 0.000	
U	U 0.000	U 0.000	
V	V 0.000	V 0.000	
W	W 0.000	W 0.000	
A	A 0.000	A 0.000	
C	C 0.000	C 0.000	
M T			
S B			
>_			
JOG **** * * *		00 : 00 : 00	
[PRGRM]	[JOG]	[CURRNT]	[NEXT] [(OPRT)]

- 4 Enter the required commands by using address keys and numeric keys on the MDI panel, then press soft key **[INPUT]** or the key to set the entered data.

```

PROGRAM (JOG)                                O0010 N00020
G00 P          (ABSOLUTE)      (DISTANCE TO GO)
X   10.000    X   0.000      X   0.000
Y           Y   0.000      Y   0.000
Z           Z   0.000      Z   0.000
U           U   0.000      U   0.000
V           V   0.000      V   0.000
W           W   0.000      W   0.000
M
S
T
B
>Z120.5_

JOG ****  ***  ***                                00 : 00 : 00
(      ) (      ) ( CLEAR ) (      ) ( INPUT )
    
```

The following data can be set:

1. G00: Positioning
2. G01: Linear interpolation
3. G28: Automatic reference position return
4. G30: 2nd/3rd/4th reference position return
5. M codes: Miscellaneous functions
6. S codes: Spindle functions
7. B codes: Second auxiliary functions

The set data is maintained even when the screen or mode is changed.

NOTE

When an alarm state exists, data cannot be set.

- 5 Press the cycle start switch on the machine operator’s panel to start command execution. The status is indicated as “MSTR.” (When the 9” screen is being used, the actual feedrate “ACT.F” and spindle speed “SACT” appear on the key input line.) The automatic operation signal, STL, can be turned on by setting bit 2 (JST) of parameter No. 7001.

```

|          ACT.F  1000 SACT      0          |
|          JOG   MASTR***MTN    00:00:00  |
    
```

NOTE

If the cycle start switch is pressed while an alarm state exists, a “START IMPOSSIBLE” warning is generated, and the entered data cannot be executed.

- 6 Upon the completion of execution, the “MSTR” status indication is cleared from the screen, and automatic operation signal STL is turned off. The set data is cleared entirely. G codes are set to G00 or G01 according to the setting of bit 0 (G01) of parameter No. 3402.

Explanations

• Positioning

An amount of travel is given as a numeric value, preceded by an address such as X, Y, or Z. This is always regarded as being an incremental command, regardless of whether G90 or G91 is specified.

The tool moves along each axis independently at the rapid traverse rate. Linear interpolation type positioning (where the tool path is linear) can also be performed by setting bit 1 (LRP) of parameter No. 1401.

	Manual rapid traverse selection switch	
	Off	On
Feedrate (parameter)	Jog feedrate for each axis (No. 1423)	Rapid traverse rate for each axis (No. 1420)
Automatic acceleration/deceleration (parameter)	Exponential acceleration/deceleration in jog feed for each axis (No. 1624)	Linear acceleration/deceleration in rapid traverse for each axis (No. 1620)
Override	Manual feed override	Rapid traverse override

NOTE

When the manual rapid traverse selection switch is set to the OFF position, the jog feedrate for each axis is clamped such that a parameter-set feedrate, determined by bit 1 (LRP) of parameter No. 1401 as shown below, is not exceeded.

LRP = 0: Manual rapid traverse rate for each axis (parameter No. 1424)

LRP = 1: Rapid traverse rate for each axis (parameter No. 1420)

• Linear interpolation (G01)

An amount of travel is given as a numeric value, preceded by an address such as X, Y, or Z. This is always regarded as being an incremental command, regardless of whether G90 or G91 is specified. Axial movements are always performed in incremental mode even during polar coordinate interpolation. In addition, movement is always performed in feed per minute mode regardless of the specification of G94 or G95.

Feedrate (parameter)	Dry run feedrate (No. 1410)
Automatic acceleration/deceleration (parameter)	Exponential acceleration/deceleration in cutting feed for each axis (No. 1622)
Override	Manual feed override

NOTE

Since the feedrate is always set to the dry run feedrate, regardless of the setting of the dry run switch, the feedrate cannot be specified using F. The feedrate is clamped such that the maximum cutting feedrate, set in parameter No. 1422, is not exceeded.

- **Automatic reference position return (G28)**

The tool returns directly to the reference position without passing through any intermediate points, regardless of the specified amount of travel. For axes for which no move command is specified, however, a return operation is not performed.

Feedrate (parameter)	Rapid traverse rate (No. 1420)
Automatic acceleration/deceleration (parameter)	Linear acceleration/deceleration in rapid traverse for each axis (No. 1620)
Override	Rapid traverse override

- **2nd, 3rd, or 4th reference position return (G30)**

The tool returns directly to the 2nd, 3rd, or 4th reference position without passing through any intermediate points, regardless of the specified amount of travel. To select a reference position, specify P2, P3, or P4 in address P. If address P is omitted, a return to the second reference position is performed.

Feedrate (parameter)	Rapid traverse rate (No. 1420)
Automatic acceleration/deceleration (parameter)	Linear acceleration/deceleration in rapid traverse for each axis (No. 1620)
Override	Rapid traverse override

NOTE

The function for 3rd/4th reference position return is optional.

- When the option is not selected
Return to the 2nd reference position is performed, regardless of the specification of address P.
- When the option is selected
If neither P2, P3, nor P4 is specified in address P, a "START IMPOSSIBLE" warning is generated, and the entered data cannot be executed.

- **M codes (miscellaneous functions)**

After address M, specify a numeric value of no more than the number of digits specified by parameter No. 3030. When M98 or M99 is specified, it is executed but not output to the PMC.

NOTE

Neither subprogram calls nor custom macro calls can be performed using M codes.

- **S codes (spindle functions)**

After address S, specify a numeric value of no more than the number of digits specified by parameter No. 3031.

NOTE

Subprogram calls cannot be performed using S codes.

- **B codes
(second auxiliary
functions)**

After address B, specify a numeric value of no more than the number of digits specified by parameter No. 3033.

NOTE

- 1 B codes can be renamed “U,” “V,” “W,” “A,” or “C” by setting parameter No. 3460. If the new name is the same as an axis name address, “B” is used. When “B” is used, and axis name “B” exists, “B” is used as the axis address. In this case, no second auxiliary function can be specified.
- 2 Subprogram calls cannot be performed using B codes.

- **Data input**

(1) When addresses and numeric values of a command are typed, then soft key **[INPUT]** is pressed, the entered data is set. In this case, the input unit is either the least input increment or calculator-type input format, according to the setting of bit 0 (DPI) of parameter No. 3401.

The key on the MDI panel can be used instead of soft key **[INPUT]**.

(2) Commands can be typed successively.

(3) Key entry is disabled during execution.

If soft key **[INPUT]** or the key on the MDI panel is pressed during execution, an “EXECUTION/MODE SWITCHING IN PROGRESS” warning is output.

(4) If input data contains an error, the following warnings may appear:

Warning	Description
FORMAT ERROR	<ul style="list-style-type: none"> – A G code other than G00, G01, and G28 has been entered. – An address other than those displayed on the manual numeric command screen has been entered.
TOO MANY DIGITS	<p>A value that exceeds the following limitations has been entered.</p> <ul style="list-style-type: none"> – Address G: 2 digits – Address P: 1 digit – Axis address: 8 digits – M, S, B: The parameter-set number of digits

NOTE

Even when the memory protection key is set, key input can nevertheless be performed.

- **Erasing data**

(1) When soft key **[CLEAR]** is pressed, followed by soft key **[EXEC]**, all the set data is cleared. In this case, however, the G codes are set to G00 or G01, depending on the setting of bit 0 (G01) of parameter No. 3402.

Data can also be cleared by pressing the key on the MDI panel.

(2) If soft key **[CLEAR]** is pressed during execution, an “EXECUTION/MODE SWITCHING IN PROGRESS” warning is output.

- **Halting execution**

If one of the following occurs during execution, execution is halted, and the data is cleared in the same way as when soft key **[CLEAR]** is pressed. The remaining distance to be traveled is canceled.

 - (1) When a feed hold is applied
 - (2) When the mode is changed to other than jog feed mode
 - (3) When an alarm is generated
 - (4) When a reset or emergency stop is applied

The M, S, and B functions remain effective even upon the occurrence of the above events, with the exception of (4).
- **Modal information**

Modal G codes and addresses used in automatic operation or MDI operation are not affected by the execution of commands specified using the manual numeric command function.
- **Jog feed**

When the tool is moved along an axis using a feed axis and direction selection switch on the manual numeric command screen, the remaining amount of travel is always shown as “0”.

Limitations

- **Constant surface speed control**

S codes cannot be specified in constant surface speed control mode.
- **T codes**

T codes cannot be specified.
- **M, S, and B functions**

While automatic operation is halted, manual numeric commands can be executed. In the following cases, however, a “START IMPOSSIBLE” warning is output, and command execution is disabled.

 - (1) When an M, S, or B function is already being executed, a manual numeric command containing an M, S, or B function cannot be executed.
 - (2) When an M, S, or B function is already being executed, and that function alone is specified or a block specifying that function also contains another function (such as a move command or dwell function) which has already been completed, a manual numeric command cannot be executed.
- **Jog feed**

When a manual numeric command is specified while the tool is being moved along an axis by using a feed axis and direction selection switch, the axial movement is interrupted, and the manual numeric command is executed. Therefore, the tool cannot be moved along an axis by using a feed axis and direction selection switch during execution of a manual numeric command.
- **Mirror image**

A mirror image cannot be produced for the direction of a specified axial movement.
- **REF mode**

The manual numeric command screen appears even when the mode is changed to REF mode. If, however, an attempt is made to set and execute data, a “WRONG MODE” warning is output and the attempt fails.

- **Functions not supporting manual numeric commands**

Manual numeric commands cannot be specified for an axis being used for spindle positioning, polygon turning, or synchronization/composite control. Attempting to execute a manual numeric command for such an axis will result in a “START IMPOSSIBLE” warning being output.

4

AUTOMATIC OPERATION

Programmed operation of a CNC machine tool is referred to as automatic operation.

This chapter explains the following types of automatic operation:

- **MEMORY OPERATION**

Operation by executing a program registered in CNC memory

- **MDI OPERATION**

Operation by executing a program entered from the MDI panel

- **DNC operation**

Operation while reading a program from external input/output device

- **PROGRAM RESTART**

Restarting a program for automatic operation from an intermediate point

- **SCHEDULING FUNCTION**

Scheduled operation by executing programs (files) registered in an external input/output device (Handy File, Floppy Cassette, or FA Card)

- **SUBPROGRAM CALL FUNCTION**

Function for calling and executing subprograms (files) registered in an external input/output device (Handy File, Floppy Cassette, or FA Card) during memory operation

- **MANUAL HANDLE INTERRUPTION**

Function for performing manual feed during movement executed by automatic operation

- **MIRROR IMAGE**

Function for enabling mirror-image movement along an axis during automatic operation

- **MANUAL INTERVENTION AND RETURN**

Function restarting automatic operation by returning the tool the position where manual intervention was started during automatic operation.

4.1 MEMORY OPERATION

Programs are registered in memory in advance. When one of these programs is selected and the cycle start switch on the machine operator's panel is pressed, automatic operation starts, and the cycle start LED goes on.



When the feed hold switch on the machine operator's panel is pressed during automatic operation, automatic operation is stopped temporarily. When the cycle start switch is pressed again, automatic operation is restarted.

When the  key on the MDI panel is pressed, automatic operation terminates and the reset state is entered.

For the two-path control, the programs for the two tool posts can be executed simultaneously so the two tool posts can operate independently at the same time.

The following procedure is given as an example. For actual operation, refer to the manual supplied by the machine tool builder.

Procedure for Memory Operation

- 1 Press the **MEMORY** mode selection switch.
- 2 Select a program from the registered programs. To do this, follow the steps below.
 - 2-1 Press  to display the program screen.
 - 2-2 Press address .
 - 2-3 Enter a program number using the numeric keys.
 - 2-4 Press the **[O SRH]** soft key.
For the two-path control, select the program for the tool post to be operated. When operating the two tool posts at the same time, select a program for each tool post.
- 3 For the two-path control, select the tool post to be operated with the tool post selection switch on the machine operator's panel.
- 4 Press the cycle start switch on the machine operator's panel. Automatic operation starts, and the cycle start LED goes on. When automatic operation terminates, the cycle start LED goes off.
- 5 To stop or cancel memory operation midway through, follow the steps below.
 - a. Stopping memory operation
Press the feed hold switch on the machine operator's panel. The feed hold LED goes on and the cycle start LED goes off. The machine responds as follows:
 - (i) When the machine was moving, feed operation decelerates and stops.
 - (ii) When dwell was being performed, dwell is stopped.
 - (iii) When M, S, or T was being executed, the operation is stopped after M, S, or T is finished.

When the cycle start switch on the machine operator's panel is pressed while the feed hold LED is on, machine operation restarts.

b. Terminating memory operation

Press the  key on the MDI panel.

Automatic operation is terminated and the reset state is entered.

When a reset is applied during movement, movement decelerates then stops.

Explanation

Memory operation

After memory operation is started, the following are executed:

- (1) A one-block command is read from the specified program.
- (2) The block command is decoded.
- (3) The command execution is started.
- (4) The command in the next block is read.
- (5) Buffering is executed. That is, the command is decoded to allow immediate execution.
- (6) Immediately after the preceding block is executed, execution of the next block can be started. This is because buffering has been executed.
- (7) Hereafter, memory operation can be executed by repeating the steps (4) to (6).

Stopping and terminating memory operation

Memory operation can be stopped using one of two methods: Specify a stop command, or press a key on the machine operator's panel.

- The stop commands include M00 (program stop), M01 (optional stop), and M02 and M30 (program end).
- There are two keys to stop memory operation: The feed hold key and reset key.

- **Program stop (M00)**

Memory operation is stopped after a block containing M00 is executed. When the program is stopped, all existing modal information remains unchanged as in single block operation. The memory operation can be restarted by pressing the cycle start button. Operation may vary depending on the machine tool builder. Refer to the manual supplied by the machine tool builder.

- **Optional stop (M01)**

Similarly to M00, memory operation is stopped after a block containing M01 is executed. This code is only effective when the Optional Stop switch on the machine operator's panel is set to ON. Operation may vary depending on the machine tool builder. Refer to the manual supplied by the machine tool builder.

- **Program end (M02, M30)**

When M02 or M30 (specified at the end of the main program) is read, memory operation is terminated and the reset state is entered. In some machines, M30 returns control to the top of the program. For details, refer to the manual supplied by the machine tool builder.

- **Feed hold**

When Feed Hold button on the operator's panel is pressed during memory operation, the tool decelerates to a stop at a time.

- **Reset**

Automatic operation can be stopped and the system can be made to the reset state by using  key on the MDI or external reset signal. When reset operation is applied to the system during a tool moving status, the motion is slowed down then stops.

- **Optional block skip**

When the optional block skip switch on the machine operator's panel is turned on, blocks containing a slash (/) are ignored.

- **Cycle start for the two-path control**

For the two-path control, a cycle start switch is provided for each tool post. This allows the operator to activate a single tool posts to operate them at the same time in memory operation or MDI operation. In general, select the tool post to be operated with the tool post selection switch on the machine operator's panel and then press the cycle start button to activate the selected tool post. (The procedure may vary with the machine tool builder. Refer to the appropriate manual issued by the machine tool builder.)

Calling a subprogram stored in an external input/output device

A file (subprogram) in an external input/output device such as a Floppy Cassette can be called and executed during memory operation. For details, see Section III-4.5.

4.2 MDI OPERATION

In the **MDI** mode, a program consisting of up to 10 lines can be created in the same format as normal programs and executed from the MDI panel. MDI operation is used for simple test operations.

The following procedure is given as an example. For actual operation, refer to the manual supplied by the machine tool builder.

Procedure for MDI Operation

- 1 Press the **MDI** mode selection switch.
For the two-path control, select the tool post for which a program is to be created with the tool post selection switch. Create a separate program for each tool post.
- 2 Press the  function key on the MDI panel to select the program screen. The following screen appears:

```

PROGRAM ( MDI )                                0010  00002

O0000;



G00 G90 G94 G40 G80 G50 G54 G69
G17 G22 G21 G49 G98 G67 G64 G15
  B  H M
  T  D
  F  S

>_

MDI  ****  ***  ***                20 : 40 : 05
{ PRGRM } { MDI } { CURRNT } { NEXT } { (OPRT) }

```

Program number O0000 is entered automatically.

- 3 Prepare a program to be executed by an operation similar to normal program editing. M99 specified in the last block can return control to the beginning of the program after operation ends. Word insertion, modification, deletion, word search, address search, and program search are available for programs created in the MDI mode. For program editing, see Chapter III-9.
- 4 To entirely erase a program created in MDI mode, use one of the following methods:
 - a. Enter address , then press the  key on the MDI panel.
 - b. Alternatively, press the  key. In this case, set bit 7 of parameter 3203 to 1 in advance.

- 5 To execute a program, set the cursor on the head of the program. (Start from an intermediate point is possible.) Push Cycle Start button on the operator's panel. By this action, the prepared program will start. (For the two-path control, select the tool post to be operated with the tool post selection switch on the machine operator's panel beforehand.)

When the program end (M02, M30) or ER (%) is executed, the prepared program will be automatically erased and the operation will end.

By command of M99, control returns to the head of the prepared program.

```

PROGRAM ( MDI )                                O0001 N00003
O0000 G00 X100.0 Z200. ;
M03 ;
G01 Z120.0 F500 ;
M93 P9010 ;
G00 Z0.0 ;
%

G00 G90 G94 G40 G80 G50 G54 G69
G17 G22 G21 G49 G98 G67 G64 G15
  B  H M
  T   D
  F   S
>_
MDI  ****  ***  ***                          12 : 42 : 39
{ PRGRM } { MDI } { CURRNT } { NEXT } { (OPRT) }

```

- 6 To stop or terminate MDI operation in midway through, follow the steps below.

a. Stopping MDI operation

Press the feed hold switch on the machine operator's panel. The feed hold LED goes on and the cycle start LED goes off. The machine responds as follows:

- (i) When the machine was moving, feed operation decelerates and stops.
- (ii) When dwell was being performed, dwell is stopped.
- (iii) When M, S, or T was being executed, the operation is stopped after M, S, or T is finished.

When the cycle start switch on the machine operator's panel is pressed, machine operation restarts.

b. Terminating MDI operation

Press the  key on the MDI panel.



Automatic operation is terminated and the reset state is entered. When a reset is applied during movement, movement decelerates then stops.

Explanation

The previous explanation of how to execute and stop memory operation also applies to MDI operation, except that in MDI operation, M30 does not return control to the beginning of the program (M99 performs this function).

• Erasing the program

Programs prepared in the **MDI** mode will be erased in the following cases:

- In MDI operation, if M02, M30 or ER(%) is executed.
(If bit 6 (MER) of parameter No. 3203 is set to 1, however, the program is erased when execution of the last block of the program is completed by single-block operation.)
- In **MEMORY** mode, if memory operation is performed.
- In **EDIT** mode, if any editing is performed.
- Background editing is performed.
- When the  and  key are pressed,
- Upon reset when bit 7 (MCL) of parameter No. 3203 is set to 1

• Restart

After the editing operation during the stop of MDI operation was done, operation starts from the current cursor position.

• Editing a program during MDI operation

A program can be edited during MDI operation. The editing of a program, however, is disabled until the CNC is reset, when bit 5 (MIE) of parameter No. 3203 is set accordingly.

Limitation

• Program registration

Programs created in MDI mode cannot be registered.

• Number of lines in a program

A program can have as many lines as can fit on one page of the screen. A program consisting of up to six lines can be created. When parameter MDL (No. 3107 #7) is set to 0 to specify a mode that suppresses the display of continuous-state information, a program of up to 10 lines can be created.

If the created program exceeds the specified number of lines, % (ER) is deleted (prevents insertion and modification).

• Subprogram nesting

Calls to subprograms (M98) can be specified in a program created in the MDI mode. This means that a program registered in memory can be called and executed during MDI operation. In addition to the main program executed by automatic operation, up to two levels of subprogram nesting are allowed (when the custom macro option is provided, up to four levels are allowed).

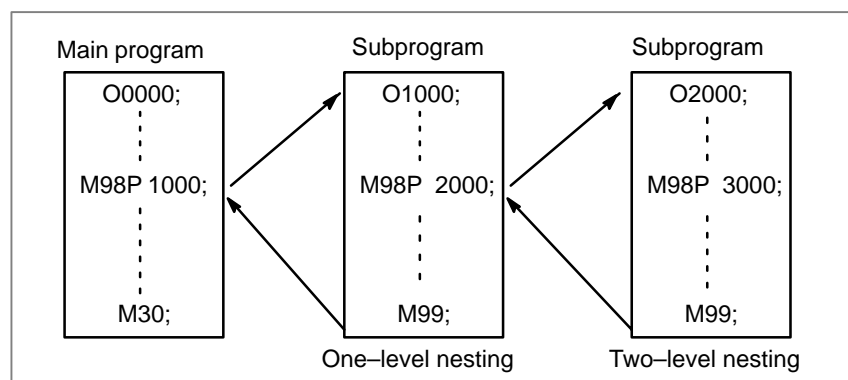

Fig. 4.2 Nesting Level of Subprograms Called from the MDI Program

- **Macro call**

When the custom macro option is provided, macro programs can also be created, called, and executed in the **MDI** mode. However, macro call commands cannot be executed when the mode is changed to **MDI** mode after memory operation is stopped during execution of a subprogram.
- **Memory area**

When a program is created in the **MDI** mode, an empty area in program memory is used. If program memory is full, no programs can be created in the **MDI** mode.

4.3 PROGRAM RESTART

This function specifies Sequence No. or Block No. of a block to be restarted when a tool is broken down or when it is desired to restart machining operation after a day off, and restarts the machining operation from that block. It can also be used as a high-speed program check function.

There are two restart methods: the P-type method and Q-type method.

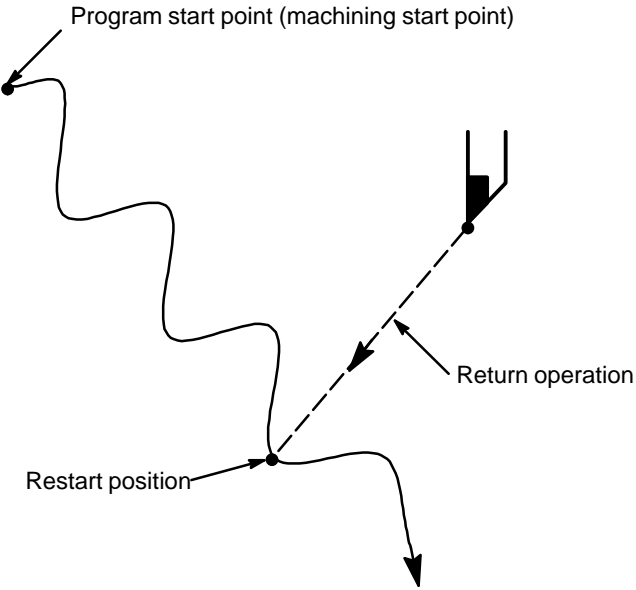
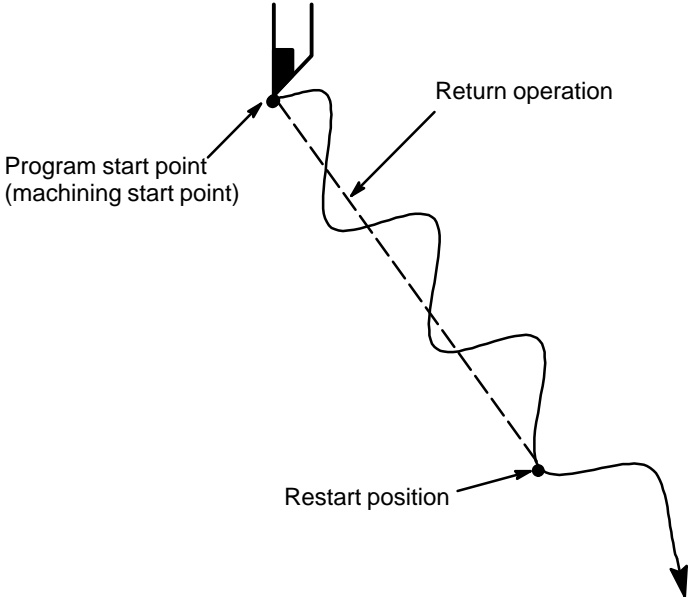
P TYPE	Operation can be restarted anywhere. This restart method is used when operation is stopped because of a broken tool.
 <p>The diagram illustrates the P-type restart method. It shows a tool path starting from a 'Program start point (machining start point)' at the top left. The path moves down and right, then curves down and left, then up and right, and finally down and right. At a point labeled 'Restart position', the tool path is interrupted. A dashed line with an arrow labeled 'Return operation' shows the tool moving back to the 'Program start point (machining start point)'. From there, the path continues as if it had never stopped.</p>	
Q TYPE	Before operation can be restarted, the machine must be moved to the programmed start point (machining start point)
 <p>The diagram illustrates the Q-type restart method. It shows a tool path starting from a 'Program start point (machining start point)' at the top left. The path moves down and right, then curves down and left, then up and right, and finally down and right. At a point labeled 'Restart position', the tool path is interrupted. A dashed line with an arrow labeled 'Return operation' shows the tool moving back to the 'Program start point (machining start point)'. From there, the path continues as if it had never stopped.</p>	

Procedure for Program restart by Specifying a sequence number

Procedure 1

[P TYPE]

- 1 Retract the tool and replace it with a new one. When necessary, change the offset. (Go to step 2.)

[Q TYPE]

- 1 When power is turned ON or emergency stop is released, perform all necessary operations at that time, including the reference position return.
- 2 Move the machine manually to the program starting point (machining start point), and keep the modal data and coordinate system in the same conditions as at the machining start.
- 3 If necessary, modify the offset amount.

Procedure 2

[COMMON TO P TYPE / Q TYPE]

- 1 Turn the program restart switch on the machine operator's panel ON.
- 2 Press function PROG key to display the desired program.
- 3 Find the program head.
- 4 Enter the sequence number of the block to be restarted, then press the **[P TYPE]** or **[Q TYPE]** soft key.

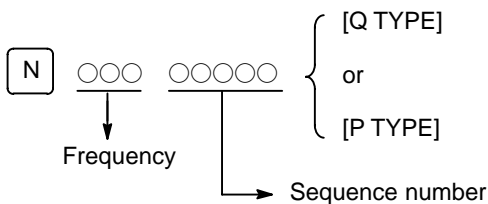
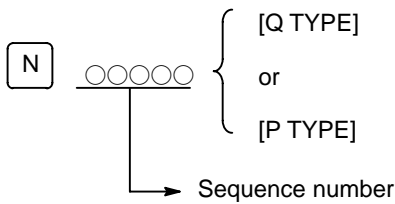

If the same sequence number appears more than once, the location of the target block must be specified. Specify a frequency and a sequence number.

- 5 The sequence number is searched for, and the program restart screen appears on the CRT display.

```

PROGRAM RESTART                                O0002 N00100

DESTINATION      M      1      2
X 57.096         1      2
Z 56.943         1      2
                 1      2
                 1      2
                 1 *****
DISTANCE TO GO   ***** *****
1 X 1.459        T ***** *****
2 Z 7.320        S *****

S 0 T0000

MEM ***** 10:10:40
{ [RSTR] } { } { FL.SDL } { } { (OPRT) }

```

DESTINATION shows the position at which machining is to restart. DISTANCE TO GO shows the distance from the current tool position to the position where machining is to restart. A number to the left of each axis name indicates the order of axes (determined by parameter setting) along which the tool moves to the restart position.

The coordinates and amount of travel for restarting the program can be displayed for up to five axes. If your system supports six or more axes, pressing the **[RSTR]** soft key again displays the data for the sixth and subsequent axes. (The program restart screen displays only the data for CNC-controlled axes.)

M: Fourteen most recently specified M codes

T: Two most recently specified T codes

S: Most recently specified S code

Codes are displayed in the order in which they are specified. All codes are cleared by a program restart command or cycle start in the reset state.

- 6 Turn the program re-start switch OFF. At this time, the figure at the left side of axis name DISTANCE TO GO blinks.
- 7 Check the screen for the M, S, and T codes to be executed. If they are found, enter the **MDI** mode, then execute the M, S and T functions. After execution, restore the previous mode. These codes are not displayed on the program restart screen.
- 8 Check that the distance indicated under DISTANCE TO GO is correct. Also check whether there is the possibility that the tool might hit a workpiece or other objects when it moves to the machining restart position. If such a possibility exists, move the tool manually to a position from which the tool can move to the machining restart position without encountering any obstacles.
- 9 Press the cycle start button. The tool moves to the machining restart position at the dry run feedrate sequentially along axes in the order specified by parameter settings (No. 7310). Machining is then restarted.

Procedure for Program Restart by Specifying a Block Number

Procedure 1

[P TYPE]

- 1 Retract the tool and replace it with a new one. When necessary, change the offset. (Go to step 2.)



[Q TYPE]

- 1 When power is turned ON or emergency stop is released, perform all necessary operations at that time, including the reference position return.
- 2 Move the machine manually to the program starting point (machining start point), and keep the modal data and coordinate system in the same conditions as at the machining start.
- 3 If necessary, modify the offset amount.



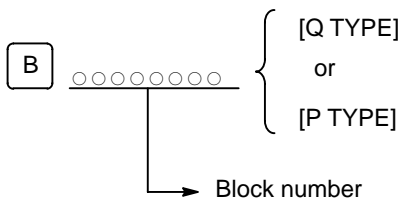

Procedure 2

[COMMON TO P TYPE /
Q TYPE]



- 1 Turn the program restart switch on the machine operator's panel ON.
- 2 Press function  key to display the desired program.
- 3 Find the program head. Press function  key.
- 4 Enter the number of the block to be restarted then press the **[P TYPE]** or **[Q TYPE]** soft key. The block number cannot exceed eight digits.
- 5 The block number is searched for, and the program restart screen appears on the display.

PROGRAM RESTART O0002 N01000

DESTINATION	BC : 00000002		
X 57.096	M 1	1	2
Z 56.943	1	1	2
	1	1	2
	1	1	2
	1	1	2
	1	*****	*****
DISTANCE TO GO	*****	*****	*****
1 X 1.459	T *****	*****	*****
2 Z 7.320	S *****		
		S 0	T0000
MEM *****		10 : 10 : 40	
			 (OPRT)

DESTINATION shows the position at which machining is to restart. DISTANCE TO GO shows the distance from the current tool position to the position where machining is to restart. A number to the left of each axis name indicates the order of axes (determined by parameter setting) along which the tool moves to the restart position.

The coordinates and amount of travel for restarting the program can be displayed for up to five axes. If your system supports six or more axes, pressing the **[RSTR]** soft key again displays the data for the sixth and subsequent axes. (The program restart screen displays only the data for CNC-controlled axes.)

M: Fourteen most recently specified M codes

T: Two most recently specified T codes

S: Most recently specified S code

B: Most recently specified B code

Codes are displayed in the order in which they are specified. All codes are cleared by a program restart command or cycle start in the reset state.

- 6 Turn the program re-start switch OFF. At this time, the figure at the left side of axis name DISTANCE TO GO blinks.
- 7 Check the screen for the M, S, T, and B codes to be executed. If they are found, enter the **MDI** mode, then execute the M, S, T, and B functions. After execution, restore the previous mode. These codes are not displayed on the program restart screen.
- 8 Check that the distance indicated under DISTANCE TO GO is correct. Also check whether there is the possibility that the tool might hit a workpiece or other objects when it moves to the machining restart position. If such a possibility exists, move the tool manually to a position from which the tool can move to the machining restart position without encountering any obstacles.
- 9 Press the cycle start button. The tool moves to the machining restart position at the dry run feedrate sequentially along axes in the order specified by parameter settings (No. 7310). Machining is then restarted.

Explanations

• Block number

When the CNC is stopped, the number of executed blocks is displayed on the program screen or program restart screen. The operator can specify the number of the block from which the program is to be restarted, by referencing the number displayed. The displayed number indicates the number of the block that was executed most recently. For example, to restart the program from the block at which execution stopped, specify the displayed number, plus one.

The number of blocks is counted from the start of machining, assuming one NC line of a CNC program to be one block.

< Example 1 >

CNC Program	Number of blocks
O 0001 ;	1
G90 G92 X0 Y0 Z0 ;	2
G01 X100. F100 ;	3
G03 X01 -50. F50 ;	4
M30 ;	5

< Example 2 >

CNC Program	Number of blocks
O 0001 ;	1
G90 G92 X0 Y0 Z0 ;	2
G90 G00 Z100. ;	3
G81 X100. Y0. Z-120. R-80. F50. ;	4
#1 = #1 + 1 ;	4
#2 = #2 + 1 ;	4
#3 = #3 + 1 ;	4
G00 X0 Z0 ;	5
M30 ;	6

Macro statements are not counted as blocks.

- **Storing / clearing the block number**
- **Block number when a program is halted or stopped**

The block number is held in memory while no power is supplied. The number can be cleared by cycle start in the reset state.

The program screen usually displays the number of the block currently being executed. When the execution of a block is completed, the CNC is reset, or the program is executed in single-block stop mode, the program screen displays the number of the program that was executed most recently.

When a CNC program is halted or stopped by feed hold, reset, or single-block stop, the following block numbers are displayed:

Feed hold : Block being executed

Reset : Block executed most recently

Single-block stop : Block executed most recently

For example, when the CNC is reset during the execution of block 10, the displayed block number changes from 10 to 9.

- **MDI intervention**
- **Block number exceeding eight digits**

When MDI intervention is performed while the program is stopped by single-block stop, the CNC commands used for intervention are not counted as a block.

When the block number displayed on the program screen exceeds eight digits, the block number is reset to 0 and counting continues.

Limitation

- **P-type restart**
- **Restart block**

Under any of the following conditions, P-type restart cannot be performed:

- When automatic operation has not been performed since the power was turned on
- When automatic operation has not been performed since an emergency stop was released
- When automatic operation has not been performed since the coordinate system was changed or shifted (change in an external offset from the workpiece reference point)

The block to be restarted need not be the block which was interrupted; operation can restart with any block. When P-type restart is performed, the restart block must use the same coordinate system as when operation was interrupted.

- **Single block** When single block operation is ON during movement to the restart position, operation stops every time the tool completes movement along an axis. When operation is stopped in the single block mode, MDI intervention cannot be performed.

- **Manual intervention** During movement to the restart position, manual intervention can be used to perform a return operation for an axis if it has not yet been performed for the axis. A return operation cannot be done further on axes for which a return has already been completed.

- **Reset** Never reset during the time from the start of a search at restart until machining is restarted. Otherwise, restart must be performed again from the first step.

- **Manual absolute** Regardless of whether machining has started or not, manual operation must be performed when the manual absolute mode is on.

- **Reference position return** If no absolute-position detector (absolute pulse coder) is provided, be sure to perform reference position return after turning on the power and before performing restart.

Alarm

Alarm No.	Contents
071	The specified block number for restarting the program is not found.
094	After interruption, a coordinate system was set, then P-type restart was specified.
095	After interruption, the coordinate system shift was changed, then P-type restart was specified.
096	After interruption, the coordinate system was changed, then P-type restart was specified.
097	When automatic operation has not been performed since the power was turned on, emergency stop was released, or P/S alarm (Nos. 094 to 097) was reset, P-type restart was specified.
098	After the power was turned on, restart operation was performed without reference position return, but a G28 command was found in the program.
099	A move command was specified from the MDI panel during a restart operation.
5020	An erroneous parameter was specified for restarting a program.

WARNING

As a rule, the tool cannot be returned to a correct position under the following conditions.

- Special care must be taken in the following cases since none of them cause an alarm:
- Manual operation is performed when the manual absolute mode is OFF.
- Manual operation is performed when the machine is locked.
- When the mirror image is used.
- When manual operation is performed in the course of axis movement for returning operation.
- When the program restart is commanded for a block between the block for skip cutting and subsequent absolute command block.
- When program restart specified for an intermediate block for a multiple repetitive canned cycle.

4.4 SCHEDULING FUNCTION

The schedule function allows the operator to select files (programs) registered on a floppy-disk in an external input/output device (Handy File, Floppy Cassette, or FA Card) and specify the execution order and number of repetitions (scheduling) for performing automatic operation. It is also possible to select only one file from the files in the external input/output device and execute it during automatic operation.

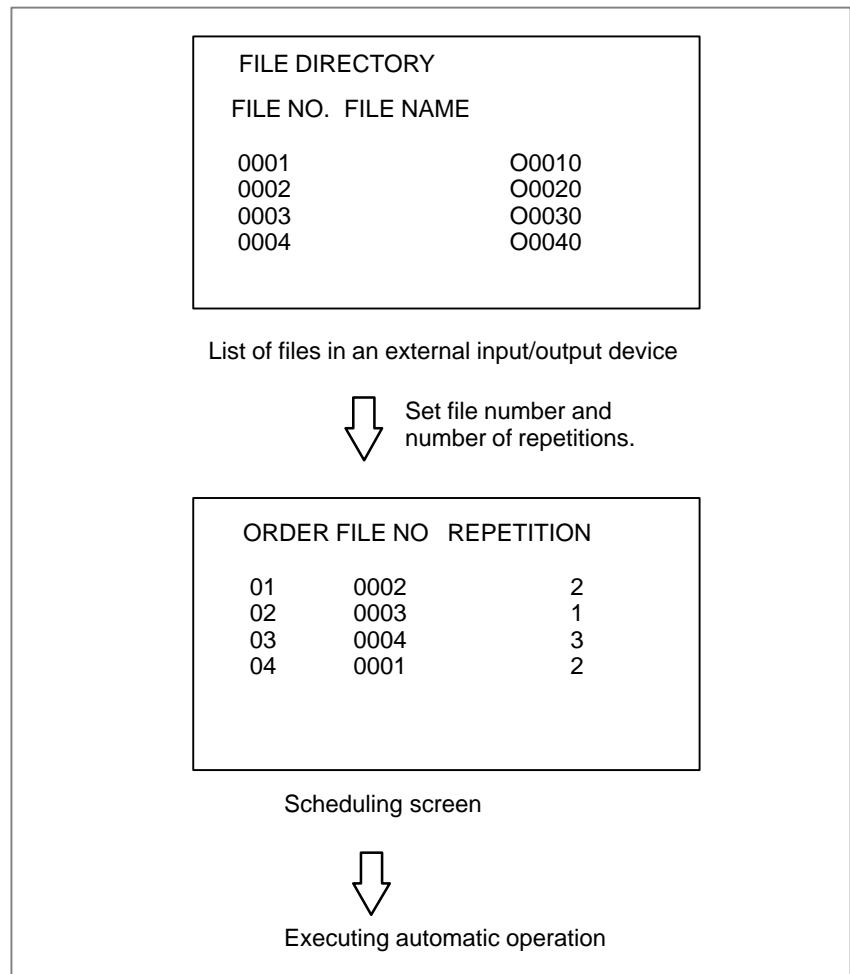

Procedure for Scheduling Function

Procedure for executing one file

- 1 Press the **MEMORY** switch on the machine operator's panel, then press the  function key on the MDI panel.
- 2 Press the rightmost soft key (continuous menu key), then press the **[FL. SDL]** soft key. A list of files registered in the Floppy Cassette is displayed on screen No. 1. To display more files that are not displayed on this screen, press the page key on the MDI panel. Files registered in the Floppy Cassette can also be displayed successively.

FILE DIRECTORY	O0001 N00000
CURRENT SELECTED : SCHEDULE	
NO. FILE NAME	(METER) VOL
0000 SCHEDULE	
0001 PARAMETER	58.5
0002 ALL PROGRAM	11.0
0003 O0001	1.9
0004 O0002	1.9
0005 O0010	1.9
0006 O0020	1.9
0007 O0040	1.9
0008 O0050	1.9
MEM **** * * * * *	19 : 14 : 47
{ PRGRM } { } { DIR } { SCHEDUL } { (OPRT) }	

Screen No. 1

- 3 Press the **{(OPRT)}** and **[SELECT]** soft keys to display “SELECT FILE NO.” (on screen No. 2). Enter a file number, then press the **[F SET]** and **[EXEC]** soft keys. The file for the entered file number is selected, and the file name is indicated after “CURRENT SELECTED:”.

FILE DIRECTORY	O0001 N00000
CURRENT SELECTED:O0040	
NO. FILE NAME	(METER) VOL
0000 SCHEDULE	
0001 PARAMETER	58.5
0002 ALL PROGRAM	11.0
0003 O0001	1.9
0004 O0002	1.9
0005 O0010	1.9
0006 O0020	1.9
0007 O0040	1.9
0008 O0050	1.9
SELECT FILE NO.=7	
> MEM **** * * * * *	19 : 17 : 10
{ F SET } { } { } { } { EXEC }	

Screen No. 2

- 4 Press the **REMOTE** switch on the machine operator’s panel to enter the **RMT** mode, then press the cycle start switch. The selected file is executed. For details on the **REMOTE** switch, refer to the manual supplied by the machine tool builder. The selected file number is indicated at the upper right corner of the screen as an F number (instead of an O number).

FILE DIRECTORY	F0007 N00000
CURRENT SELECTED:O0040	
RMT **** * * * * *	13 : 27 : 54
{ PRGRM } { } { DIR } { SCHEDUL } { (OPRT) }	

Screen No. 3

- Procedure for executing the scheduling function

- 1 Display the list of files registered in the Floppy Cassette. The display procedure is the same as in steps 1 and 2 for executing one file.
- 2 On screen No. 2, press the **[OPRT]** and **[SELECT]** soft keys to display “SELECT FILE NO.”
- 3 Enter file number 0, and press the **[F SET]**, and **[EXEC]** soft keys. “SCHEDULE” is indicated after “CURRENT SELECTED:”.
- 4 Press the left most soft key (return menu key) and the **[SCHEDUL]** soft key. Screen No. 4 appears.

FILE DIRECTORY	F0000 N02000		
ORDER	FILE NO.	REQ.REP	CUR.REP
01			
02			
03			
04			
05			
06			
07			
08			
09			
10			
>_			
MEM **** * * * * *	22 : 07 : 00		
{ PRGRM } { } { DIR } { SCHEDUL } { (OPRT) }			

Screen No. 4

Move the cursor and enter the file numbers and number of repetitions in the order in which to execute the files. At this time, the current number of repetitions “CUR.REP” is 0.

- 5 Press the **REMOTE** switch on the machine operator’s panel to enter the **RMT** mode, then press the start switch. The files are executed in the specified order. When a file is being executed, the cursor is positioned at the number of that file. The current number of repetitions CUR.REP is increased when M02 or M30 is executed in the program being run.

FILE DIRECTORY				O0000	N02000
ORDER	FILE NO.	REQ.REP	CUR.REP		
01	0007	5	5		
02	0003	23	23		
03	0004	9999	156		
04	0005	LOOP	0		
05					
06					
07					
08					
09					
10					
RMT	****	***	***	10 : 10 : 40	
(PRGRM)	() (DIR)	(SCHEDUL)	((OPRT))	

Screen No. 5

Explanations

- **Specifying no file number**

If no file number is specified on screen No. 4 (the file number field is left blank), program execution is stopped at that point. To leave the file number field blank, press numeric key then .

- **Endless repetition**

If a negative value is set as the number of repetitions, <LOOP> is displayed, and the file is repeated indefinitely.

- **Clear**

When the [(OPRT)], [CLEAR], and [EXEC] soft keys are pressed on screen No. 4, all data is cleared. However, these keys do not function while a file is being executed.

- **Return to the program screen**

When the [PRGRM] soft key is pressed on screen No. 1, 2, 3, 4, or 5, the program screen is displayed.

Limitation

- **Number of repetitions**

Up to 9999 can be specified as the number of repetitions. If 0 is set for a file, the file becomes invalid and is not executed.

- **Number of files registered**

By pressing the page key on screen No. 4, up to 20 files can be registered.

- **M code**

When M codes other than M02 and M30 are executed in a program, the current number of repetitions is not increased.

- **Displaying the floppy disk directory during file execution**

During the execution of file, the floppy directory display of background editing cannot be referenced.

- **Restarting automatic operation**

To resume automatic operation after it is suspended for scheduled operation, press the reset button.

- **Scheduling function for the two-path control**

The scheduling function can be used only for a single tool post.

Alarm

Alarm No.	Description
086	An attempt was made to execute a file that was not registered in the floppy disk.
210	M198 and M99 were executed during scheduled operation, or M198 was executed during DNC operation.

4.5 SUBPROGRAM CALL FUNCTION (M198)

The subprogram call function is provided to call and execute subprogram files stored in an external input/output device (Handy File, FLOPPY CASSETTE, FA Card) during memory operation.

When the following block in a program in CNC memory is executed, a subprogram file in the external input/output device is called:

To use this function, the Floppy Cassette directory display option must be installed.

Format

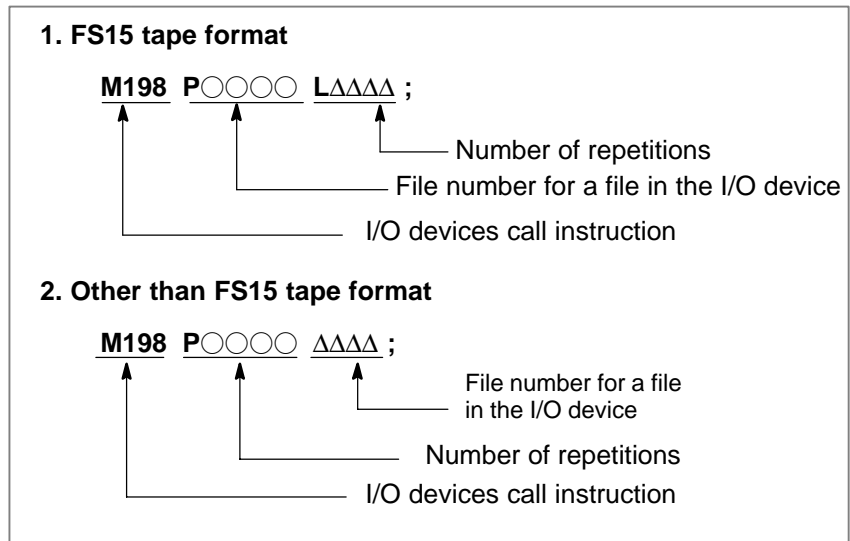

Explanation

The subprogram call function is enabled when parameter No. 0102 for the input/output device is set to 3. When the custom macro option is provided, either format 1 or 2 can be used. A different M code can be used for a subprogram call depending on the setting of parameter No. 6030. In this case, M198 is executed as a normal M code. The file number is specified at address P. If the SBP bit (bit 2) of parameter No. 3404 is set to 1, a program number can be specified. When a file number is specified at address P, Fxxxx is indicated instead of Oxxxx.

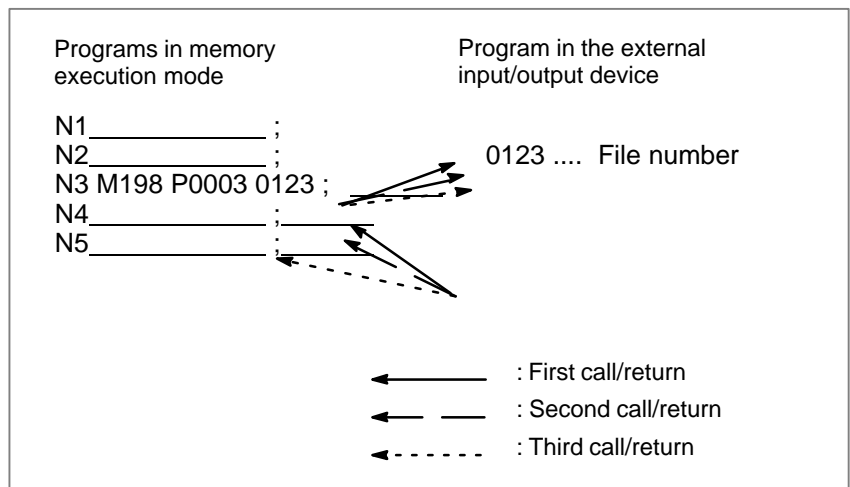

Fig. 4.5 Program Flow When M198 is Specified

Restrictions

For the two-path control, subprograms in a floppy cassette cannot be called for the two tool posts at the same time.

NOTE

- 1 When M198 in the program of the file saved in a floppy cassette is executed, a P/S alarm (No.210) is given. When a program in the memory of CNC is called and M198 is executed during execution of a program of the file saved in a floppy cassette, M198 is changed to an ordinary M-code.
- 2 When MDI is intervened and M198 is executed after M198 is commanded in the memory mode, M198 is changed to an ordinary M-code. When the reset operation is done in the MDI mode after M198 is commanded in the MEMORY mode, it does not influence on the memory operation and the operation is continued by restarting it in the MEMORY mode.

4.6 MANUAL HANDLE INTERRUPTION

The movement by manual handle operation can be done by overlapping it with the movement by automatic operation in the automatic operation mode.

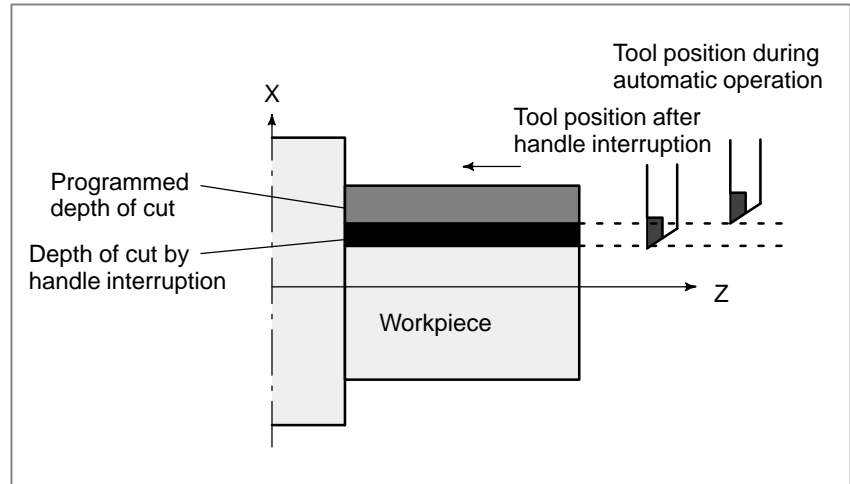

Fig. 4.6 Manual Handle Interruption

- **Handle interruption axis selection signals**

For the handle interruption axis selection signals, refer to the manual supplied by the machine tool builder.

During automatic operation, handle interruption is enabled for an axis if the handle interruption axis selection signal for that axis is on. Handle interruption is performed by turning the handle of the manual pulse generator.

WARNING

The travel distance by handle interruption is determined according to the amount by which the manual pulse generator is turned and the handle feed magnification ($\times 1$, $\times 10$, $\times M$, $\times N$).

Since this movement is not accelerated or decelerated, it is very dangerous to use a large magnification value for handle interruption.

The move amount per scale at $\times 1$ magnification is 0.001 mm (metric output) or 0.0001 inch (inch output).

NOTE

Handle interruption is disabled when the machine is locked during automatic operation.

Explanations

• Relation with other functions

The following table indicates the relation between other functions and the movement by handle interrupt.

Display	Relation
Machine lock	Machine lock is effective. The tool does not move even when this signal turns on.
Interlock	Interlock is effective. The tool does not move even when this signal turns on.
Mirror image	Mirror image is not effective. Interrupt functions on the plus direction by plus direction command, even if this signal turns on.

• Position display

The following table shows the relation between various position display data and the movement by handle interrupt.

Display	Relation
Absolute coordinate value	Handle interruption does not change absolute coordinates.
Relative coordinate value	Handle interruption does not change relative coordinates.
Machine coordinate value	Machine coordinates are changed by the travel distance specified by handle interruption.

• Travel distance display

Press the function key , then press the chapter selection soft key **[HNDL]**.

The move amount by the handle interrupt is displayed. The following 4 kinds of data are displayed concurrently.

HANDLE INTERRUPTION		O000 N00200	
(INPUT UNIT)		(OUTPUT UNIT)	
X 69.594		X 69.594	
Z -61.439		Z -61.439	
(RELATIVE)		(DISTANCE TO GO)	
U 0.000		X 0.000	
W 0.000		Z 0.000	
RUN TIME	1H 12M	PART COUNT	287
		CYCLE TIME	0H 0M 0S
MDI	****	***	***
			10 : 29 : 51
{ ABS }	{ REL }	{ ALL }	{ HNDL }
			{ (OPRT) }

(a) INPUT UNIT :

Handle interrupt move amount in input unit system
Indicates the travel distance specified by handle interruption according to the least input increment.

(b) OUTPUT UNIT :

Handle interrupt move amount in output unit system
Indicates the travel distance specified by handle interruption according to the least command increment.

(c) RELATIVE :

Position in relative coordinate system

These values have no effect on the travel distance specified by handle interruption.

(d) DISTANCE TO GO :

The remaining travel distance in the current block has no effect on the travel distance specified by handle interruption.

The handle interrupt move amount is cleared when the manual reference position return ends every axis.

- **Display for five-axis systems or better**

Systems having five or more axes provide the same display as the overall position display. See III-11.1.3.

4.7 MIRROR IMAGE

During automatic operation, the mirror image function can be used for movement along an axis. To use this function, set the mirror image switch to ON on the machine operator’s panel, or set the mirror image setting to ON from the CRT/MDI (or LCD/MDI).

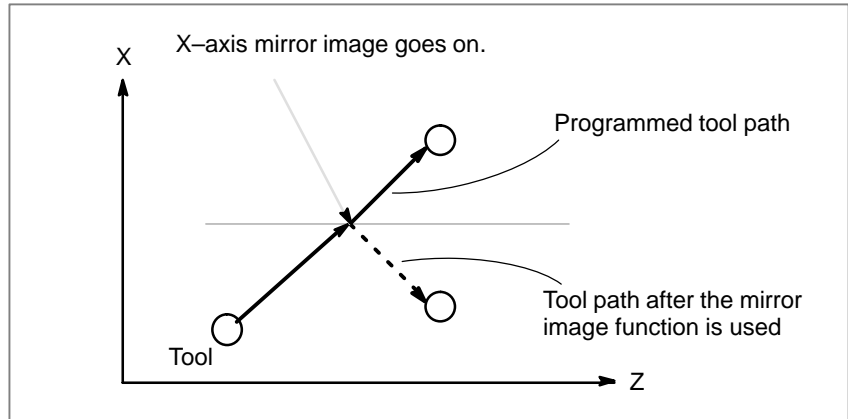

Fig. 4.7 Mirror Image

Procedure

The following procedure is given as an example. For actual operation, refer to the manual supplied by the machine tool builder.

- 1 Press the single block switch to stop automatic operation. When the mirror image function is used from the beginning of operation, this step is omitted.
- 2 Press the mirror image switch for the target axis on the machine operator’s panel.
Alternatively, turn on the mirror image setting by following the steps below:

2-1 Set the **MDI** mode.

2-2 Press the  function key.

2-3 Press the **[SETTING]** soft key for chapter selection to display the setting screen.

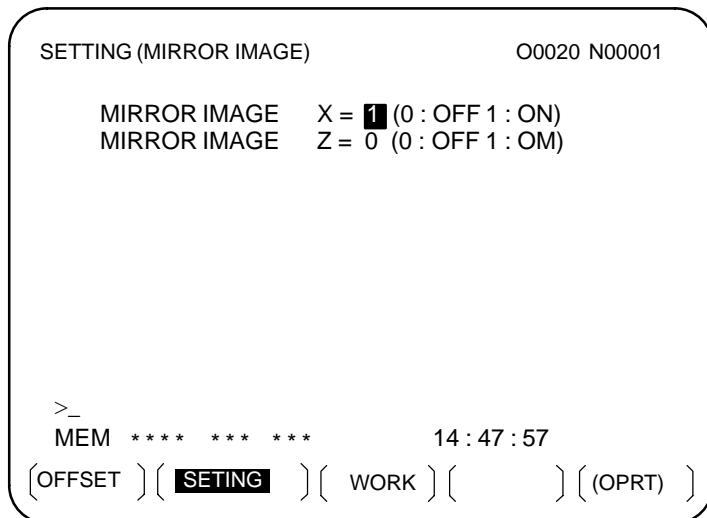

2-4 Move the cursor to the mirror image setting position, then set the target axis to 1.

- 3 Enter an automatic operation mode (memory mode or MDI mode), then press the cycle start button to start automatic operation.

Explanations

- The mirror image function can also be turned on and off by setting bit 0 (MIRx) of parameter (No. 0012) to 1 or 0.
- For the mirror image switches, refer to the manual supplied by the machine tool builder.

Restrictions

The direction of movement during manual operation, the direction of movement from an intermediate point to the reference position during automatic reference position return (G28).

4.8 MANUAL INTERVENTION AND RETURN

In cases such as when tool movement along an axis is stopped by feed hold during automatic operation so that manual intervention can be used to replace the tool: When automatic operation is restarted, this function returns the tool to the position where manual intervention was started. To use the conventional program restart function and tool withdrawal and return function, the switches on the operator's panel must be used in conjunction with the MDI keys. This function does not require such operations.

Explanations

- **Manual absolute on/off**
In manual absolute off mode, the tool does not return to the stop position, but instead operates according to the manual absolute on/off function.
- **Override**
For the return operation, the dry run feedrate is used, and the jog feedrate override function is enabled.
- **Return operation**
Return operation is performed according to positioning based on nonlinear interpolation.
- **Single block**
If the single block stop switch is on during return operation, the tool stops at the stop position and restarts movement when the cycle start switch is pressed.
- **Cancellation**
If a reset occurs or an alarm is issued during manual intervention or the return operation, this function is cancelled.
- **MDI mode**
This function can be used in the MDI mode as well.

Restrictions

- **Enabling and disabling manual intervention and return**
This function is enabled only when the automatic operation hold LED is on. When there is no travel distance remaining, this function has no effect even if a feed hold stop is performed with the automatic operation hold signal *SP (bit 5 of G008).
- **Offset**
When the tool is replaced using manual intervention for a reason such as damage, the tool movement cannot be restarted by a changed offset in the middle of the interrupted block.
- **Machine lock, mirror image, and scaling**
When performing manual intervention, never use the machine lock, mirror image, or scaling functions.

Example

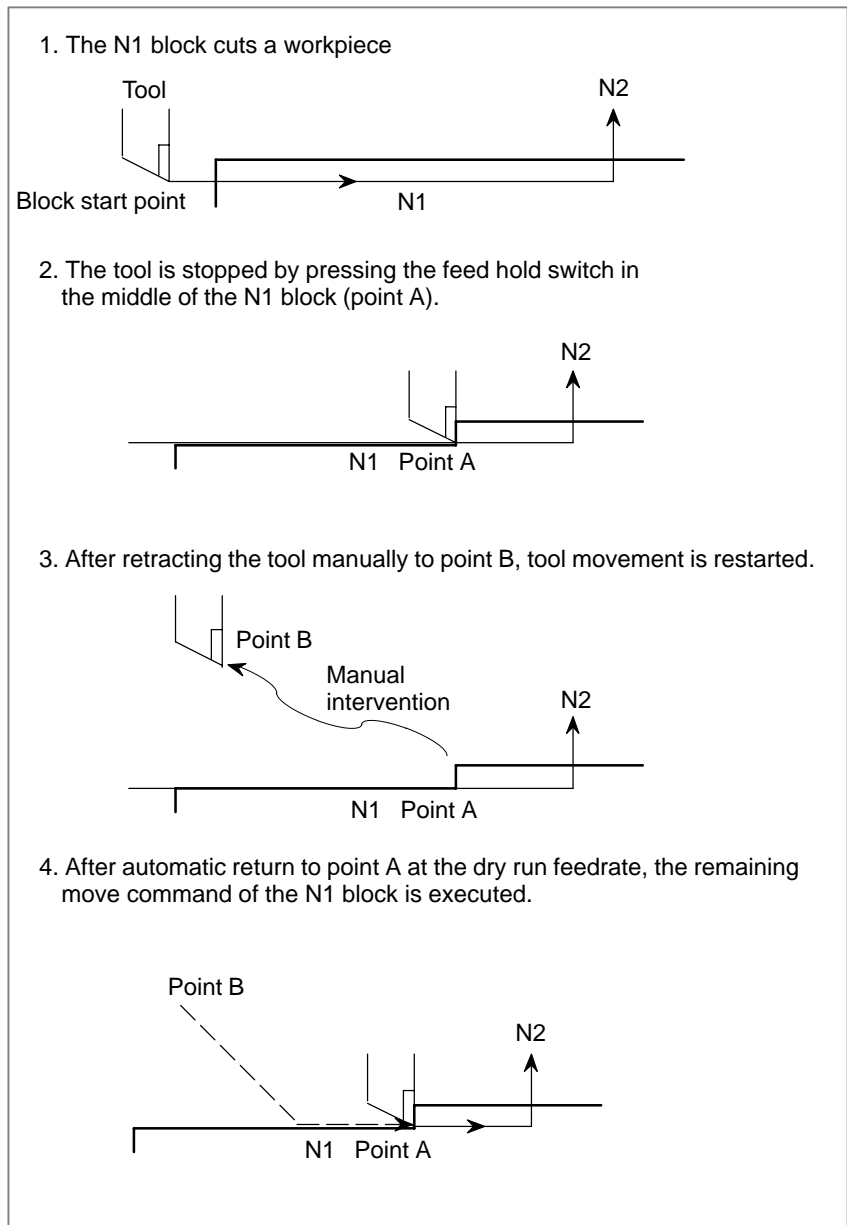

WARNING

When performing manual intervention, pay particular attention of machining and the shape of the workpiece so that the machine and tool are not damaged.

4.9 DNC OPERATION

By activating automatic operation during the DNC operation mode (RMT), it is possible to perform machining (DNC operation) while a program is being read in via reader/puncher interface, or remote buffer. If the floppy cassette directory display option is available, it is possible to select files (programs) saved in an external input/output unit of a floppy format (Handy File, Floppy Cassettes, or FA card) and specify (schedule) the sequence and frequency of execution for automatic operation. To use the DNC operation function, it is necessary to set the parameters related to the reader/punch interface, and remote buffer in advance.

DNC OPERATION

Procedure

- 1 Search for the program (file) to be executed.
- 2 Press the REMOTE switch on the machine operator's panel to set RMT mode, then press the cycle start switch. The selected file is executed. For details of the use of the REMOTE switch, refer to the relevant manual supplied by the machine tool builder.

- Program check screen
(7 soft key type)

```

PROGRAM CHECK                                F0001 N00020
N020 X100.0 Z100.0 (DNC-PROG) ;
N030 X200.0 Z200.0 ;
N050 X400.0 Z400.0 ;

(RELATIVE) (DIST TO GO) G00 G17 G90
X 100.000 X 0.000 G22 G94 G21
Y 100.000 Y 0.000 G41 G49 G80
Z 0.000 Z 0.000 G98 G50 G67
A 0.000 A 0.000 B
C 0.000 C 0.000 H M
HD.T NX.T D M
F S M
ACT.F SACT REPEAT
RMT STRT MTN *** *** 21:20:05
[ ABS ] [ REL ] [ ] [ ] [ (OPRT) ]

```

- Program screen
(7 soft key type)

```

PROGRAM                                F0001 N00020
N020 X100.0 Z100.0 (DNC-PROG) ;
N030 X200.0 Z200.0 ;
N040 X300.0 Z300.0 ;
N050 X400.0 Z400.0 ;
N060 X500.0 Z500.0 ;
N070 X600.0 Z600.0 ;
N080 X700.0 Z400.0 ;
N090 X800.0 Z400.0 ;
N100 x900.0 z400.0 ;
N110 x1000.0 z1000.0 ;
N120 x800.0 z800.0 ;

RMT STRT MTN *** *** 21:20:05
[ PRGRM ] [ CHECK ] [ ] [ ] [ (OPRT) ]

```

- **Program screen
(12 soft key type)**

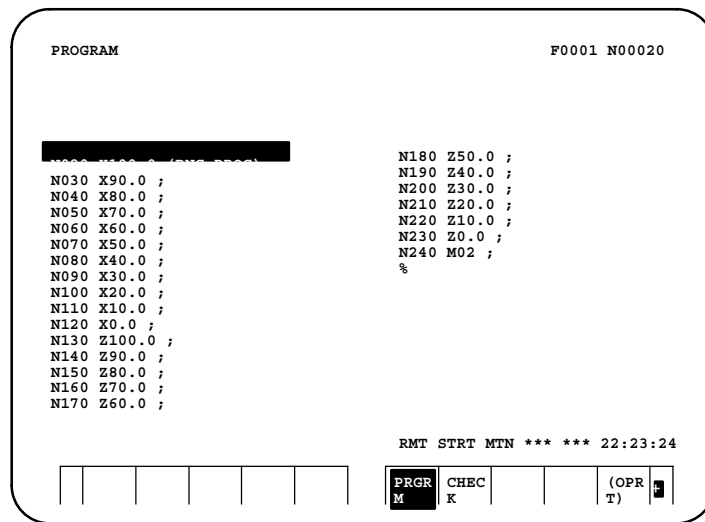

During DNC operation, the program currently being executed is displayed on the program check screen and program screen.

The number of displayed program blocks depends on the program being executed.

Any comment enclosed between a control-out mark (()) and control-in mark (()) within a block is also displayed.

Explanations

- During DNC operation, programs and macro programs stored in memory can be called.

Limitations

- **Limit on number of characters**
- **M198 (command for calling a program from within an external input/output unit)**
- **Custom macro**

In program display, no more than 256 characters can be displayed. Accordingly, character display may be truncated in the middle of a block.

In DNC operation, M198 cannot be executed. If M198 is executed, P/S alarm No. 210 is issued.

In DNC operation, custom macros can be specified, but no repeat instruction and branch instruction can be programmed. If a repeat instruction or branch instruction is executed, P/S alarm No. 123 is issued. When reserved words (such as IF, WHILE, COS, and NE) used with custom macros in DNC operation are displayed during program display, a blank is inserted between adjacent characters.

Example

[During DNC operation]

```

#102=SIN[#100] ;   →   #102 = S I N[#100] ;
IF[#100NE0]GOTO5 ; →   I F[#100NE0] G O T O 5 ;

```

- **M99**

When control is returned from a subprogram or macro program to the calling program during DNC operation, it becomes impossible to use a return command (M99P****) for which a sequence number is specified.

Alarm

Number	Message	Contents
086	DR SIGNAL OFF	When entering data in the memory by using Reader / Puncher interface, the ready signal (DR) of reader / puncher was turned off. Power supply of I/O unit is off or cable is not connected or a P.C.B. is defective.
123	CAN NOT USE MACRO COMMAND IN DNC	Macro control command is used during DNC operation. Modify the program.
210	CAN NOT COMAND M198/M199	Or M198 is executed in the DNC operation. Modify the program.

4.10 DNC OPERATION WITH MEMORY CARD

4.10.1 Specification

“DNC operation with Memory Card” is a function that it is possible to perform machining with executing the program in the memory card, which is assembled to the memory card interface, where is the left side of the screen.

There are two methods to use this function as follows.

- (a) By starting automatic operation (cycle start) during the DNC operation mode (RMT), it is possible to perform machining (DNC operation) while a program is being read from a memory card, as by using the external input/output unit such as a floppy cassette and so on. (Fig. 4.10.1 (a))
- (b) It is possible to read sub-programs written in the memory card and execute them by the command Subprogram call (M198). (Fig. 4.10.1 (b))

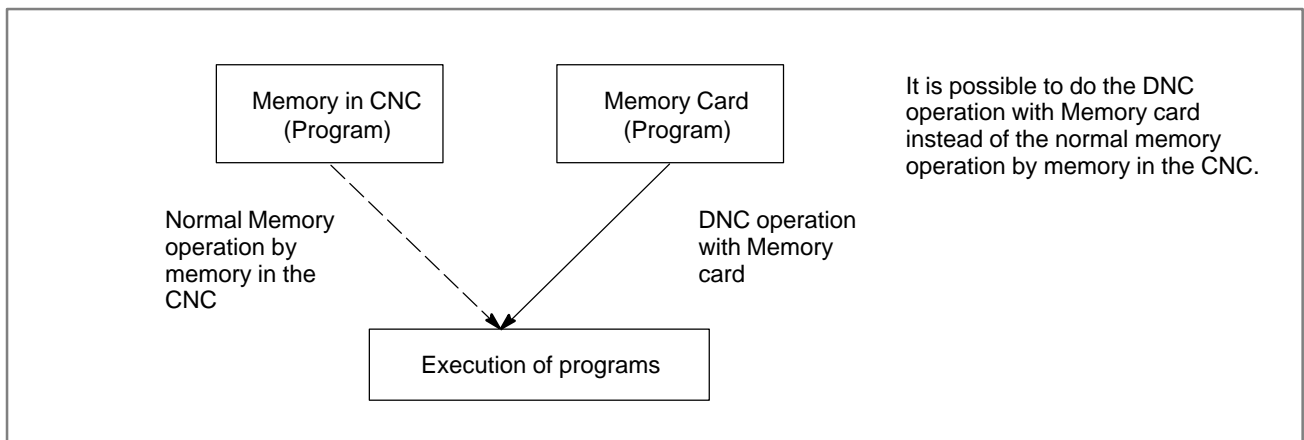

Fig. 4.10.1 (a)

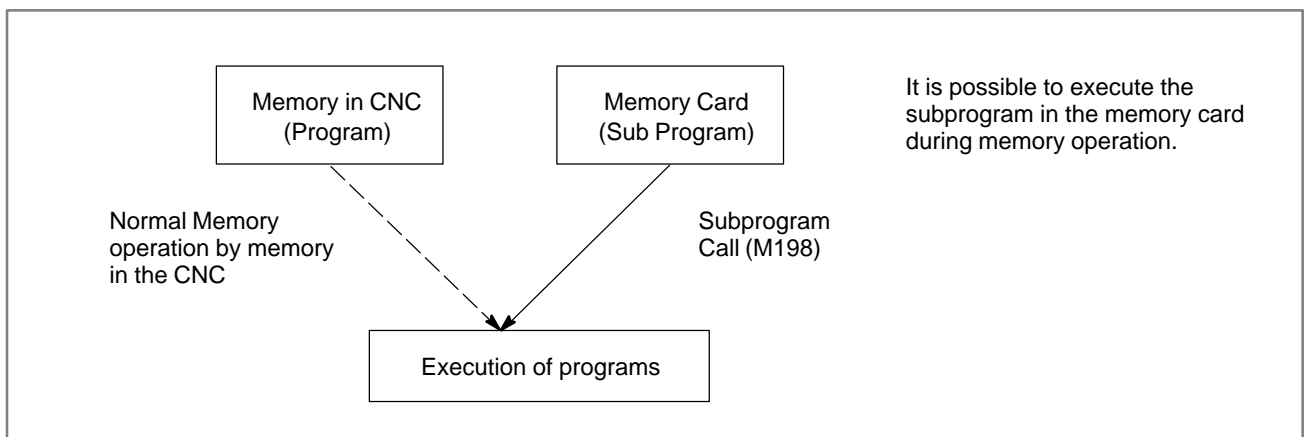

Fig. 4.10.1 (b)

NOTE

- 1 To use this function, it is necessary to set the parameter of No.20 to 4 by setting screen.
No.20 [I/O CHANNEL: Setting to select an input/output unit]
Setting value is 4.: It means using the memory card interface.
- 2 When CNC control unit is a stand-alone type, the memory card interface on the left side of the screen of the display unit is available. But the interface on the control unit is not available.

4.10.2 Operations

4.10.2.1 DNC operation

Procedure

Please set the parameter of No.20 to 4 in the setting screen in advance.

- (1) Change to RMT mode.
- (2) Push [PROGRAM] function key.
- (3) Push [>] soft key (continuance menu).
- (4) When [DNC-CD] soft key is pushed, the following screen is displayed.
- (5) The screen can be scrolled by page key. An arbitrary file number is input, and [F SRH] soft key is pushed. Then the arbitrary file name is displayed at the top of DNC operation (memory card) screen.
- (6) When the file number that is executed is input and the [DNC-ST] soft key is pushed, the file name that is selected is set to DNC FILE.
- (7) When the cycle start is done, the program that is selected is executed.

DNC OPERATION (M CARD)			00001	N00001
NO.	FILE NAME	SIZE	DATE	
0001	MAIN. PRG	800013	99	02 03
0002	DNC1. PRG	50	99	03-23
0003	DNC2. PRG	38	99	03 24
0004	DNC3. PRG	32	99	03-24
0005	DNC4. PRG	50	99	03 23
0006	CNCPARAM. DAT	2304	99	03-24
0007	TOOLOFST. DAT	838	99	03 24
0008	O1234	170	99	03-24
0009	O7777	528	99	03 24

DNC FILE NAME : MAIN. PRG

} ^

RMT	****	***	***	14:20:23
[F SRH]				[DNC-ST]

4.10.2.2 Subprogram call (M198)

When the following block in a program in CNC memory is executed, a subprogram file in memory card is called.

Format

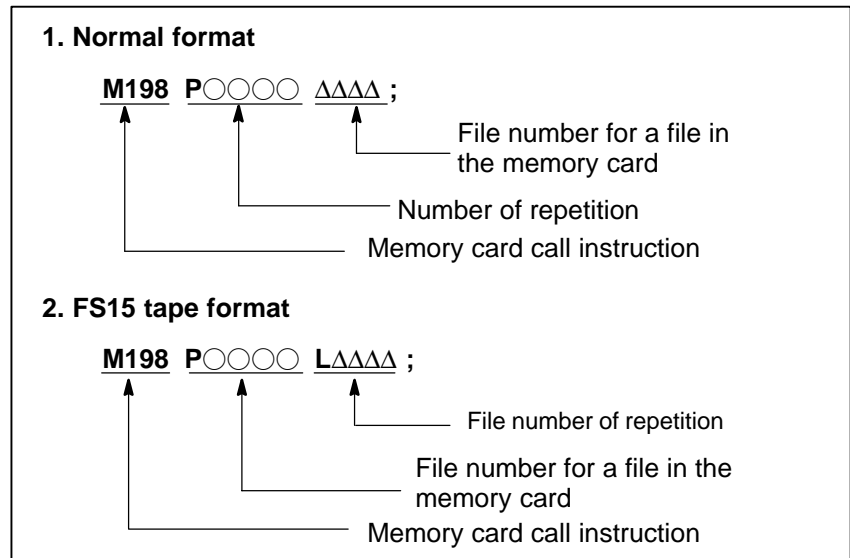

Explanation

When the custom macro option is provided, both format 1 and 2 can be used. A different M code can be used for a subprogram call depending on the setting of parameter No. 6030. In this case, M198 is executed as a normal M code. The file number is specified at address P. If the SBP (bit 2) of parameter No. 3404 is set to 1, a program number can be specified. When a file number is specified at address P, Fxxxx is indicated instead of Oxxxx.

NOTE

Please set the parameter of No. 20 to 4 in the setting screen in advance.

4.10.3 Limitation and Notes

- (1) The memory card can not be accessed, such as display of memory card list and so on, during the DNC operation with memory card.
- (2) It is possible to execute the DNC operation with memory card on multi path system. However, it is not possible to call programs from the plural paths at the same time.
- (3) The selection of DNC operation file that is set at DNC OPERATION screen is cleared by the power supply turn off and on. After the power supply is turned on again, it is necessary to select the DNC operation file again.
- (4) Please do not pull out and insert memory card during the DNC operation with memory card.
- (5) It is not possible to call a program in the memory card from the DNC operation program.
- (6) In case of using this function, the PMCIA card attachment written at section 6 must be used to prevent a poor connection of the memory card from occurring by vibration of the machine.
- (7) In case of the stand-alone type *i* series that the display unit is a Display link unit, this function can not be used.
- (8) The memory card interface on the stand-alone type controller is not available. Please use the memory card interface on the display unit.

4.10.4 Parameter

	#7	#6	#5	#4	#3	#2	#1	#0
0138	DNM							

[Data type] Bit

- #7 (DNM)** The DNC operation with memory card function is
 0 : disable.
 1 : enable.

4.10.5 Connecting PCMCIA Card Attachment

4.10.5.1 Specification number

Specification	Remarks
A02B-0236-K160	For 7.2" LCD or 8.4" LCD
A02B-0236-K161	For 9.5" LCD or 10.4" LCD

4.10.5.2 Assembling

1) How to assemble to the unit

Assemble an attachment guide and a control unit to the cabinet by screwing together as follow figure.

The attachment guide is 1.6mm thick. Pay attention for the length of the screws when you assemble them.

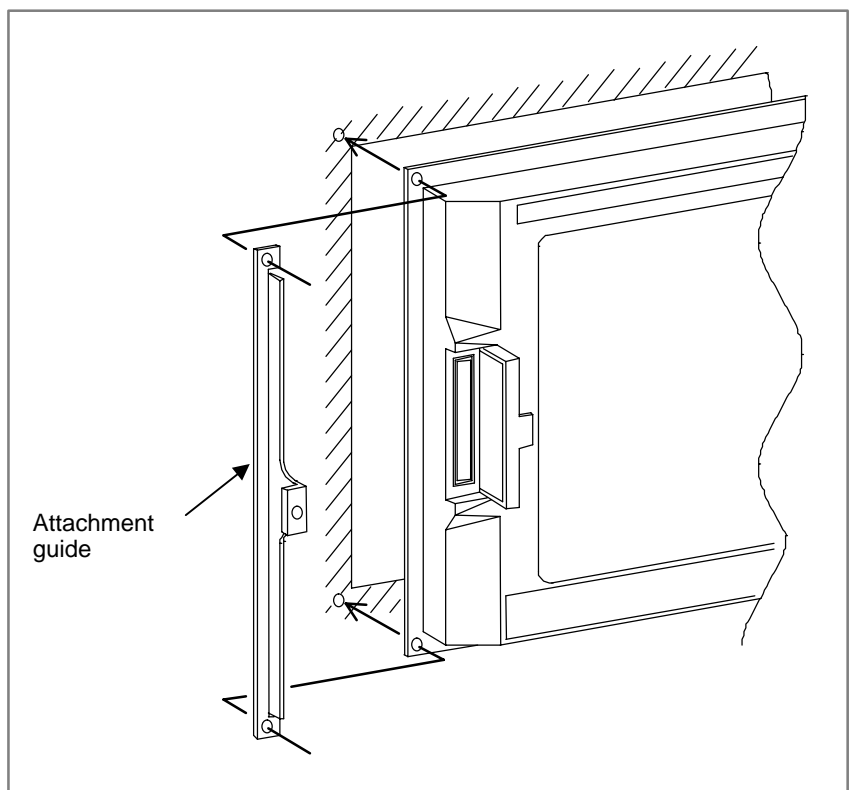

2) How to mount the card

(a) Insert the card to slit of the attachment. Please pay attention to the direction of the card. (Please mach the direction of ditch on the card.)

(b) Push up the card to the upper end of the attachment.

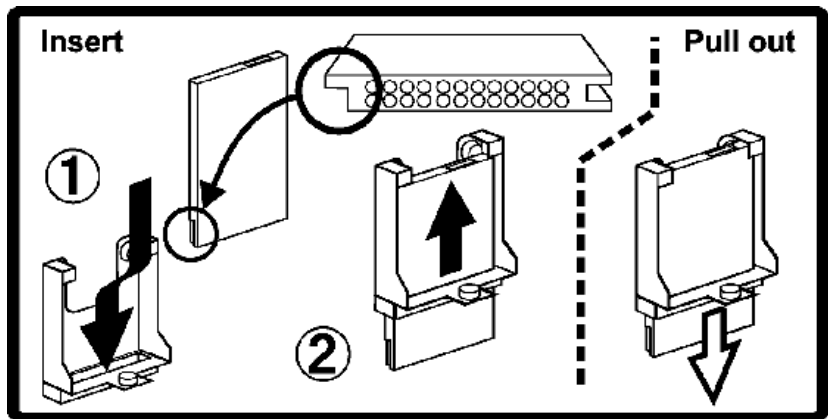

3) Assembling of the attachment

Insert the memory card with the attachment into the memory card interface as following figure. And, fix the attachment guide by screwing the screw of the attachment guide by manual.

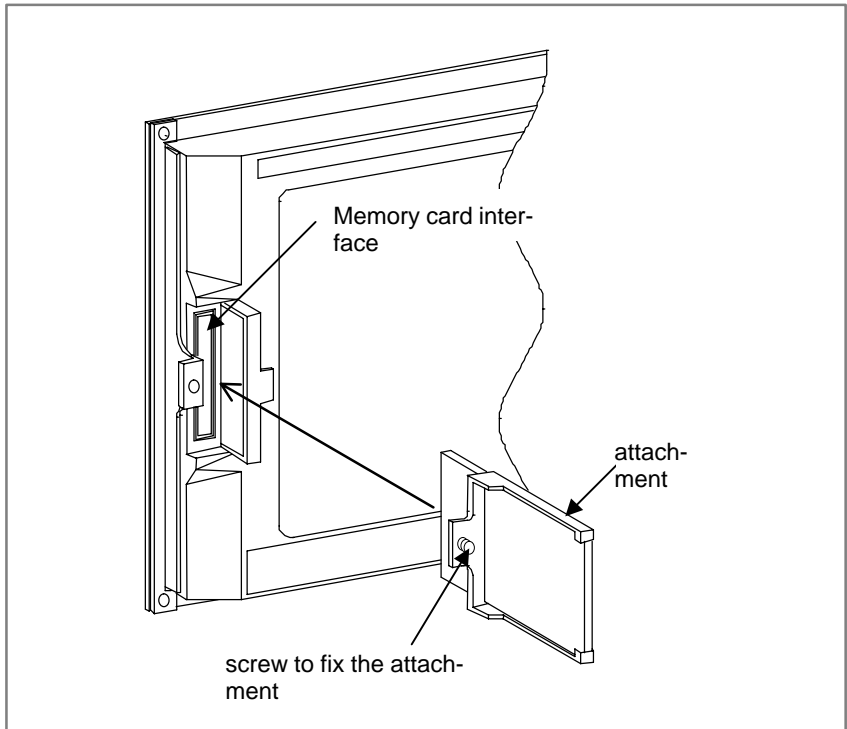

4) Appearance after connection

**NOTE**

- 1 In both case of stand-alone type *i* series and LCD mounted type *i* series, the memory card interface where is the left side of the screen of the display unit. (The memory card interface on the stand-alone type controller is not available.)
- 2 It is impossible to assemble the display unit and the attachment guide from inside of the cabinet.
- 3 The memory card must be used in the condition, as the coolant cannot be poured directly on it.

4.10.6 Recommended Memory Card

Maker	Type	Capacity
Hitachi LTD	HB289016A4	16MB
	HB289032A4	32MB
	HB289160A4	160MB
Matsushita electric	BN-012AB	12MB
	BN-020AB	20MB
	BN-040AB	40MB
SanDisk	SDP3B-4	4MB
	SDP3B-20	20MB
	SDP3B-40	40MB

5 TEST OPERATION



The following functions are used to check before actual machining whether the machine operates as specified by the created program.

- 1. Machine Lock and Auxiliary Function Lock**
- 2. Feedrate Override**
- 3. Rapid Traverse Override**
- 4. Dry Run**
- 5. Single Block**

5.1 MACHINE LOCK AND AUXILIARY FUNCTION LOCK

To display the change in the position without moving the tool, use machine lock.

There are two types of machine lock, all-axis machine lock, which stops the movement along all axes, and specified-axis machine lock, which stops the movement along specified axes only. In addition, auxiliary function lock, which disables M, S, and T commands, is available for checking a program together with machine lock.

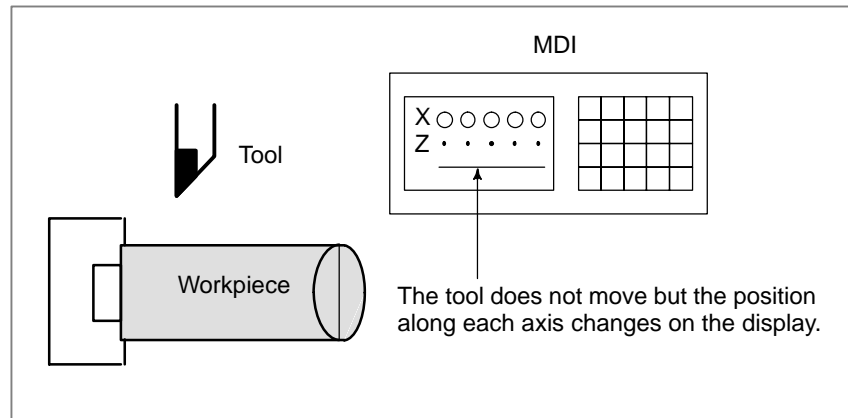

Fig. 5.1 Machine lock

Procedure for Machine Lock and Auxiliary Function Lock

- **Machine Lock**

Press the machine lock switch on the operator's panel. The tool does not move but the position along each axis changes on the display as if the tool were moving.

Some machines have a machine lock switch for each axis. On such machines, press the machine lock switches for the axes along which the tool is to be stopped. Refer to the appropriate manual provided by the machine tool builder for machine lock.

WARNING

The positional relationship between the workpiece coordinates and machine coordinates may differ before and after automatic operation using machine lock. In such a case, specify the workpiece coordinate system by using a coordinate setting command or by performing manual reference position return.

- **Auxiliary Function Lock**

Press the auxiliary function lock switch on the operator's panel. M, S, T, and B codes are disabled and not executed. Refer to the appropriate manual provided by the machine tool builder for auxiliary function lock.

Restrictions

- **M, S, T, and B command by only machine lock** M, S, T, and B commands are executed in the machine lock state.
- **Reference position return under Machine Lock** When a G27, G28, or G30 command is issued in the machine lock state, the command is accepted but the tool does not move to the reference position and the reference position return LED does not go on.
- **M codes not locked by auxiliary function lock** M00, M01, M02, M30, M98, M99, and M198 commands (subprogram call function) are executed even in the auxiliary function lock state. M codes for calling a subprogram (parameters No. 6071 to 6079) and those for calling a custom macro (parameter No. 6080 to 6089) are also executed.

5.2 FEEDRATE OVERRIDE

A programmed feedrate can be reduced or increased by a percentage (%) selected by the override dial. This feature is used to check a program. For example, when a feedrate of 100 mm/min is specified in the program, setting the override dial to 50% moves the tool at 50 mm/min.

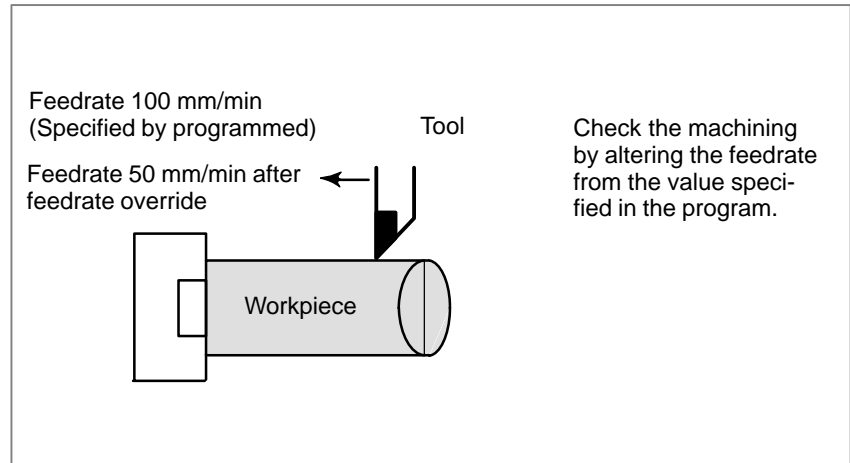
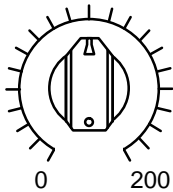

Fig. 5.2 Feedrate override

Procedure for Feedrate Override



JOG FEED RATE OVERRIDE

Set the feedrate override dial to the desired percentage (%) on the machine operator's panel, before or during automatic operation. On some machines, the same dial is used for the feedrate override dial and manual continuous feedrate dial. Refer to the appropriate manual provided by the machine tool builder for feedrate override.

Restrictions

- **Override Range**

The override that can be specified ranges from 0 to 254%. For individual machines, the range depends on the specifications of the machine tool builder.

- **Override during thread**

During threading, the override is ignored and the feedrate remains as specified by program.

5.3 RAPID TRAVERSE OVERRIDE

An override of four steps (F0, 25%, 50%, and 100%) can be applied to the rapid traverse rate. F0 is set by a parameter (No. 1421).

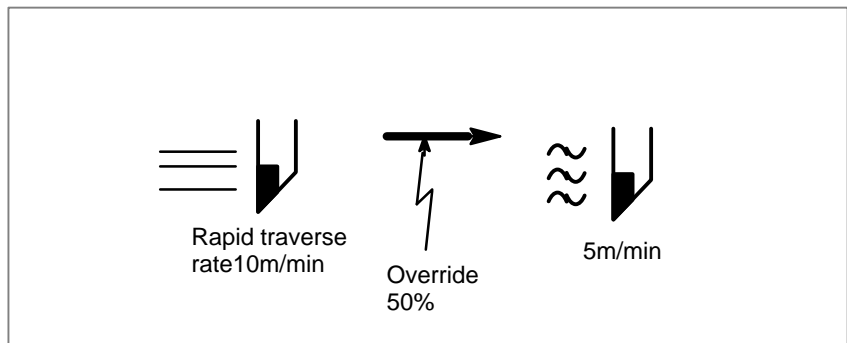
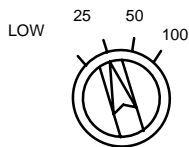

Fig. 5.3 Rapid traverse override

Procedure for Rapid Traverse Override

Select one of the four feedrates with the rapid traverse override switch during rapid traverse. Refer to the appropriate manual provided by the machine tool builder for rapid traverse override.



Rapid traverse override

Explanation

The following types of rapid traverse are available. Rapid traverse override can be applied for each of them.

- 1) Rapid traverse by G00.
- 2) Rapid traverse during a canned cycle.
- 3) Rapid traverse in G27, G28 and G30.
- 4) Manual rapid traverse.
- 5) Rapid traverse of manual reference position return

5.4 DRY RUN

The tool is moved at the feedrate specified by a parameter regardless of the feedrate specified in the program. This function is used for checking the movement of the tool under the state that the workpiece is removed from the table.

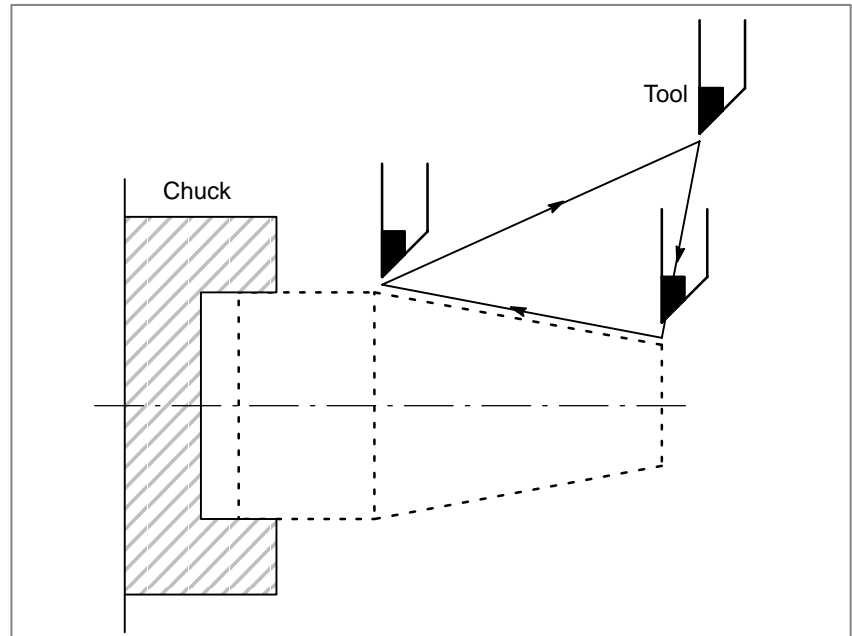

Fig. 5.4 Dry run

Procedure for Dry Run

Press the dry run switch on the machine operator's panel during automatic operation. The tool moves at the feedrate specified in a parameter. The rapid traverse switch can also be used for changing the feedrate. Refer to the appropriate manual provided by the machine tool builder for dry run.

Explanation

- Dry run feedrate

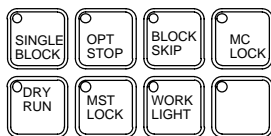

The dry run feedrate changes as shown in the table below according to the rapid traverse switch and parameters.

Rapid traverse button	Program command	
	Rapid traverse	Feed
ON	Rapid traverse rate	Dry run feedrate×JVmax *2)
OFF	Dry run speed × JV, or rapid traverse rate *1)	Dry run feedrate × JV

Max. cutting feedrate Setting by parameter No. 1422
 Rapid traverse rate Setting by parameter No. 1420
 Dry run feedrate Setting by parameter No. 1410

JV: Jog feedrate override

*1) Dry run feedrate x JV when parameter RDR (bit 6 of No. 1401) is

1. Rapid traverse rate when parameter RDR is 0.

*2) Clamped to the maximum cutting feedrate

JVmax: Maximum value of jog feedrate override

5.5 SINGLE BLOCK

Pressing the single block switch starts the single block mode. When the cycle start button is pressed in the single block mode, the tool stops after a single block in the program is executed. Check the program in the single block mode by executing the program block by block.

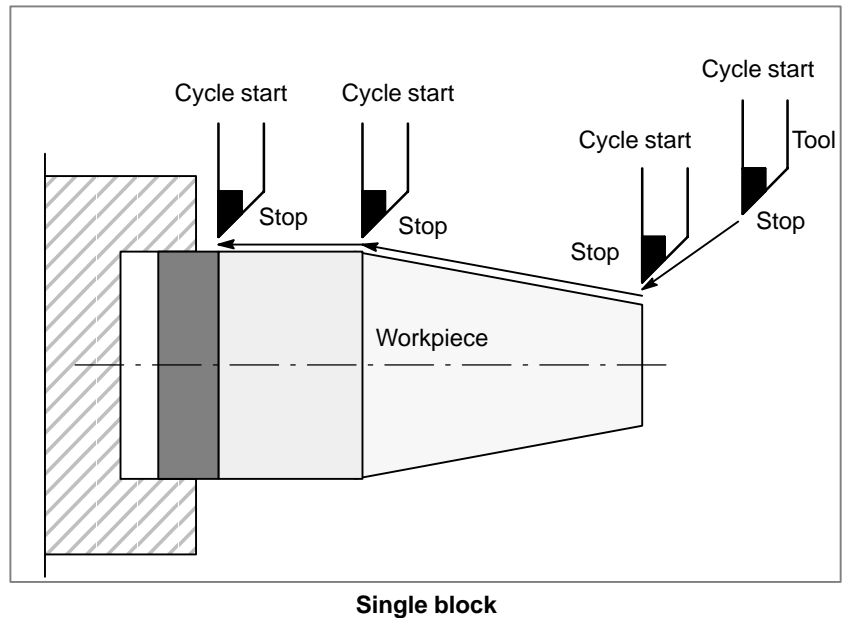

Procedure for Single Block

- 1 Press the single block switch on the machine operator's panel. The execution of the program is stopped after the current block is executed.
- 2 Press the cycle start button to execute the next block. The tool stops after the block is executed.

Refer to the appropriate manual provided by the machine tool builder for single block execution.

Explanation

- **Reference position return and single block**
- **Single block during a canned cycle**

If G28 to G30 are issued, the single block function is effective at the intermediate point.

In a canned cycle, the single block stop points are as follows.

		- - -> Rapid traverse	
		S : Single block - - -> Cutting feed	
		Tool path	
		Explanation	
☆G90 (Outer/inner turning cycle)	Straight cutting cycle	Taper cutting cycle	Tool path 1 to 4 is assumed as one cycle. After 4 is finished, a stop is made.
☆G92 (Threading cycle)	Straight threading cycle	Taper threading cycle	Tool path 1 to 4 is assumed as one cycle. After 4 is finished, a stop is made.
☆G94 (End surface turning cycle)	Straight end surface cutting cycle	Taper end surface cutting cycle	Tool path 1 to 4 is assumed as one cycle. After 4 is finished, a stop is made.
☆G70 (Finishing cycle)			Tool path 1 to 7 is assumed as one cycle. After 7 is finished, a stop is made.
☆G71 (Outer surface rough machining cycle) G72 (End surface rough machining cycle)			Each tool path 1 to 4,5 to 8,9 to 12, 13 to 16 and 17 to 20 is assumed as one cycle. After each cycle is finished, a stop is made.

This figure shows the case for G71. G72 is the same.

Fig. 5.5 Single block during canned cycle (1/2)

	Tool path	Explanation
<p>☆G73 (Closed-loop cutting cycle)</p>		<p>Tool path 1 to 6 is assumed as one cycle. After 10 is finished, a stop is made.</p>
<p>☆G74 (End surface cutting-off cycle) G75 (Outer/inner surface cutting-off cycle)</p>	<p>This figure shows the case for G74. G75 is the same.</p>	<p>Tool path 1 to 10 is assumed as one cycle. After 10 is finished, a stop is made.</p>
<p>☆G76 (Multiple repetitive threading cycle)</p>		<p>Tool path 1 to 4 is assumed as one cycle. After 4 is finished, a stop is made.</p>

Fig. 5.5 Single block during canned cycle (2/2)

● Subprogram call and single block

Single block stop is not performed in a block containing M98P_; M99; or G65.

However, single block stop is even performed in a block with M98P_ or M99 command, if the block contains an address other than O, N or P.

- **Special single-block control**

Two-path control supports a single-block command signal for each of tool posts 1 and 2. Single-block stop can thus be specified for the automatic operation program for each tool post. Note, however, that when the single-block command signals for both tool posts 1 and 2 are turned on, the tools may stop at different positions according to the command programs.

The special single-block control function eliminates such a difference by applying feed hold to a tool post when the other tool post enters single-block stop mode.

The special single-block control function is enabled when bit 6 (DSB) of parameter No. 8100 is set to 1.

The single-block command signals for tool posts 1 and 2 are effective even when the special single-block control function is used.

When tool post 1 or 2 is placed in the single-block mask state or feed-hold mask state by a threading or custom macro program, the tool is not stopped until the mask state is terminated.

The tool posts are not synchronized. Therefore, if the following programs are executed, feed hold is applied to tool post 2 upon the completion of X10.0 for tool post 1, but the tool of tool post 2 is not stopped exactly at X10.0.

Tool post 1	Tool post 2
O0001 ;	O0002 ;
G50 X0 ;	G50 X0 ;
G01 X10. F100 ;	G01 X20. F100 ;
G01 X20. ;	

6 SAFETY FUNCTIONS



To immediately stop the machine for safety, press the Emergency stop button. To prevent the tool from exceeding the stroke ends, Overtravel check and Stroke check are available. This chapter describes emergency stop, overtravel check, and stroke check.

6.1 EMERGENCY STOP

If you press Emergency Stop button on the machine operator's panel, the machine movement stops in a moment.

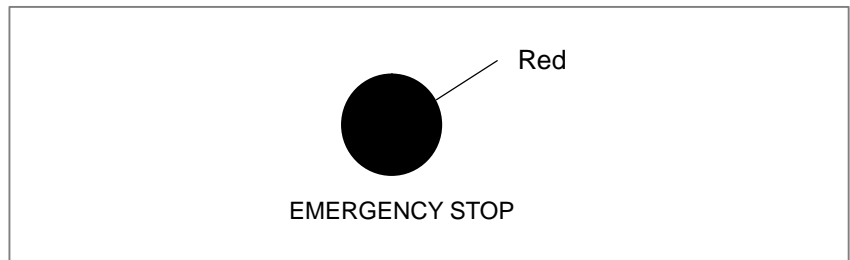

Fig. 6.1 Emergency stop

This button is locked when it is pressed. Although it varies with the machine tool builder, the button can usually be unlocked by twisting it.

Explanation

EMERGENCY STOP interrupts the current to the motor.
Causes of trouble must be removed before the button is released.

6.2 OVERTRAVEL

When the tool tries to move beyond the stroke end set by the machine tool limit switch, the tool decelerates and stops because of working the limit switch and an OVER TRAVEL is displayed.

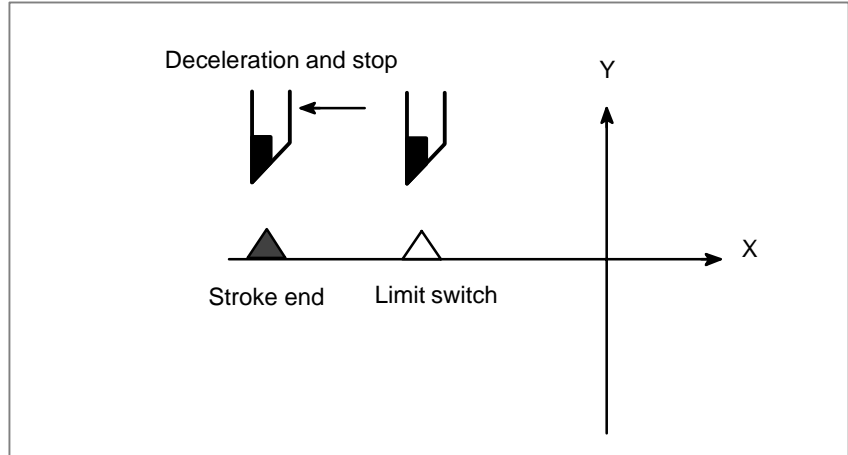

Fig. 6.2 Overtravel

Explanation

- **Overtravel during automatic operation**
- **Overtravel during manual operation**
- **Releasing overtravel**
- **Alarm**

When the tool touches a limit switch along an axis during automatic operation, the tool is decelerated and stopped along all axes and an overtravel alarm is displayed.

In manual operation, the tool is decelerated and stopped only along the axis for which the tool has touched a limit switch. The tool still moves along the other axes.

Press the reset button to reset the alarm after moving the tool to the safety direction by manual operation. For details on operation, refer to the operator’s manual of the machine tool builder.

No.	Message	Description
506	Overtravel: +n	The tool has exceeded the hardware-specified overtravel limit along the positive nth axis (n: 1 to 8).
507	Overtravel: -n	The tool has exceeded the hardware-specified overtravel limit along the negative nth axis (n: 1 to 8).

6.3 STORED STROKE CHECK

There areas which the tool cannot enter can be specified with stored stroke check 1, stored stroke check 2, and stored stroke check 3.

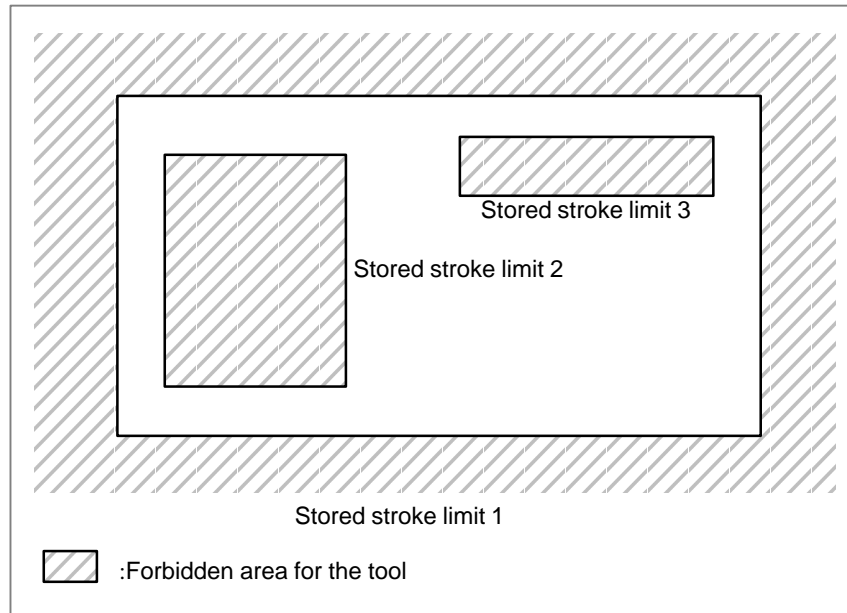

Fig. 6.3 (a) Stroke check

When the tool exceeds a stored stroke limit, an alarm is displayed and the tool is decelerated and stopped.

When the tool enters a forbidden area and an alarm is generated, the tool can be moved in the reverse direction from which the tool came.

Explanation

- **Stored stroke check 1**
- **Stored stroke check 2 (G22, G23)**

Parameters (Nos. 1320, 1321 or Nos. 1326, 1327) set boundary. Outside the area of the set limits is a forbidden area. The machine tool builder usually sets this area as the maximum stroke.

Parameters (Nos. 1322, 1323) or commands set these boundaries. Inside or outside the area of the limit can be set as the forbidden area. Parameter OUT (No. 1300#0) selects either inside or outside as the forbidden area.

In case of program command a G22 command forbids the tool to enter the forbidden area, and a G23 command permits the tool to enter the forbidden area. Each of G22; and G23; should be commanded independently of another commands in a block.

The command below creates or changes the forbidden area:

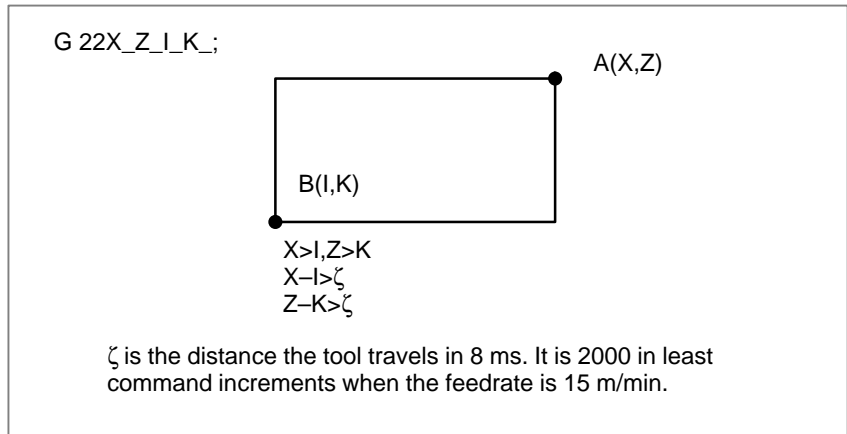

Fig. 6.3 (b) Creating or changing the forbidden area using a program

When setting the area by parameters, points A and B in the figure below must be set.

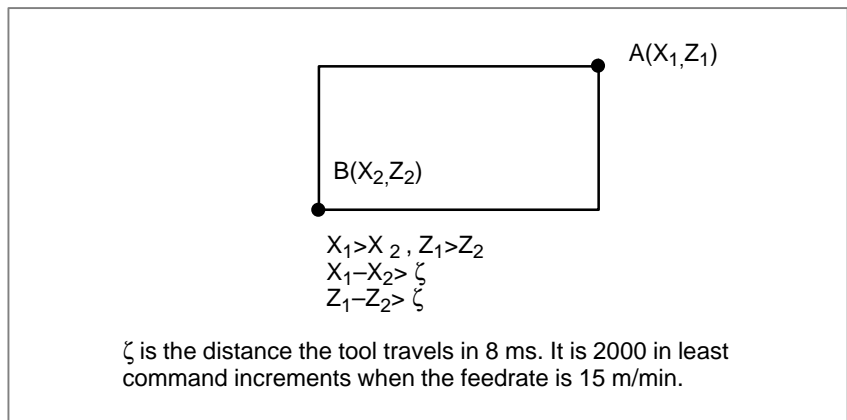

Fig. 6.3 (c) Creating or changing the forbidden area using a parameters

In stored stroke check 2, even if you mistake the order of the coordinate value of the two points, a rectangular, with the two points being the apexes, will be set as the area.

When you set the forbidden area X₁, Z₁, X₂, and Z₂ through parameters (Nos. 1322, 1323), the data should be specified by the distance from the reference position in the least command increment. (Output increment)

If set the forbidden area XZIK by a G22 command, specify the data by the distance from the reference position in the least input increment (Input increment.) The programmed data are then converted into the numerical values in the least command increment, and the values are set as the parameters.

● **Stored stroke check 3**

Set the boundary with parameters No. 1324 and 1325. The area inside the boundary becomes the forbidden area.

- **Checkpoint for the forbidden area**

The parameter setting or programmed value (XZIK) depends on which part of the tool or tool holder is checked for entering the forbidden area. Confirm the checking position (the top of the tool or the tool chuck) before programming the forbidden area.

If point C (The top of the tool) is checked in Fig. 6.3 (d), the distance “c” should be set as the data for the stored stroke limit function. If point D (The tool chuck) is checked, the distance “d” must be set.

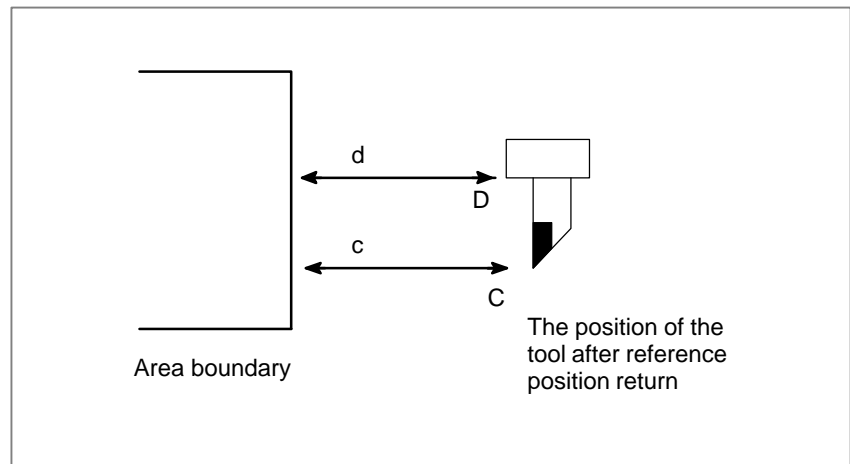

Fig. 6.3 (d) Setting the forbidden area

- **Forbidden area over-lapping**

Area can be set in piles.

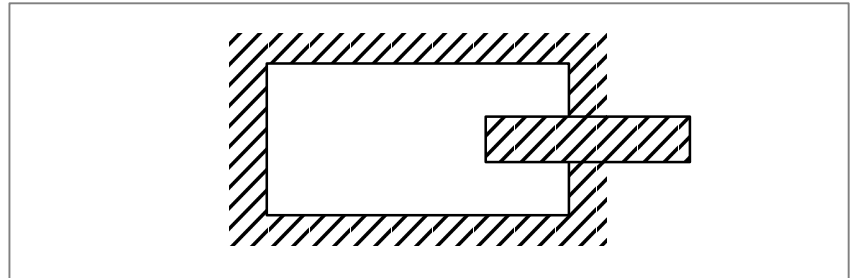

Fig. 6.3 (e) Setting the forbidden area over lapping

Unnecessary limits should be set beyond the machine stroke.

- **Effective time for a forbidden area**

Each limit becomes effective after the power is turned on and manual reference position return or automatic reference position return by G28 has been performed.

After the power is turned on, if the reference position is in the forbidden area of each limit, an alarm is generated immediately. (Only in G22 mode for stored stroke limit 2).

- **Releasing the alarms**

When the tool has become unmovable in the forbidden area, push the emergency stop button to release the forbidden condition and move the tool out of the forbidden area in the G23 mode; then, if the setting is wrong, correct it and perform the reference position return again.

- **Change from G23 to G22 in a forbidden area**

When G23 is switched to G22 in the forbidden area, the following results.

- (1) When the forbidden area is inside, an alarm is informed in the next move.
- (2) When the forbidden area is outside, an alarm is informed immediately.

- **Setting the forbidden area for the two-path control**

For the two-path control, set a forbidden area for each tool post.

NOTE

In setting a forbidden area, if the two points to be set are the same, the area is as follows:

- (1) When the forbidden area is stored stroke check 1, all areas are forbidden areas.
- (2) When the forbidden area is stored stroke check 2 or stored stroke check 3 all areas are movable areas.

- **Overrun amount of stored stroke limit**

If the maximum rapid traverse rate is F (mm/min), the maximum overrun amount, L (mm), of the stored stroke limit is obtained from the following expression:

$$L \text{ (mm)} = F/7500$$

The tool enters the specified inhibited area by up to L (mm). Bit 7 (BFA) of parameter No. 1300 can be used to stop the tool when it reaches a point L mm short of the specified area. In the case, the tool will not enter the inhibited area.

- **Timing for displaying an alarm**

Parameter BFA (bit 7 of No. 1300) selects whether an alarm is displayed immediately before the tool enters the forbidden area or immediately after the tool has entered the forbidden area.

ALram

Number	Message	Contents
500	OVER TRAVEL: +n	Exceeded the n-th axis (1-8) + side stored stroke limit 1.
501	OVER TRAVEL: -n	Exceeded the n-th axis (1-8) - side stored stroke limit 1.
502	OVER TRAVEL: +n	Exceeded the n-th axis (1-8) + side stored stroke limit 2.
503	OVER TRAVEL: -n	Exceeded the n-th axis (1-8) - side stored stroke limit 2.
504	OVER TRAVEL: +n	Exceeded the n-th axis (1-8) + side stored stroke limit 3.
505	OVER TRAVEL: -n	Exceeded the n-th axis (1-8) - side stored stroke limit 3.

6.4 CHUCK AND TAILSTOCK BARRIERS



The chuck–tailstock barrier function prevents damage to the machine by checking whether the tool tip fouls either the chuck or tailstock.

Specify an area into which the tool may not enter (entry–inhibition area). This is done using the special setting screen, according to the shapes of the chuck and tailstock. If the tool tip should enter the set area during a machining operation, this function stops the tool and outputs an alarm message.

The tool can be cleared from the area only by retracting it in the direction opposite to that in which the tool entered the area.

Setting the chuck and tailstock barriers

- **Setting the shapes of the chuck and tailstock**

- 1 Press the  function key.
- 2 Press the  continuous menu key. Then, press the **[BARRIER]** chapter selection soft key.
- 3 Pressing the page key toggles the display between the chuck barrier setting screen and tailstock barrier setting screen.

Chuck barrier setting screen

BARRIER (CHUCK) O0000 N00000

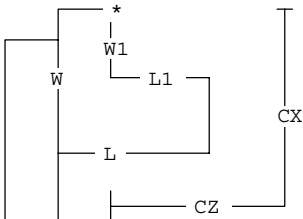

TY=0 (0:IN, 1:OUT)

L = 50.000

W = 60.000

L1= **25.000**

W1= 30.000

CX= 200.000

CZ= -100.000

ACTUAL POSITION (ABSOLUITE)

X 200.000 Z 50.000

>_

MDI **** * * * * 14:46:09

[] [W.SHFT] [] [**BARRIER**] [(OPRT)]

Tailstock barrier setting screen

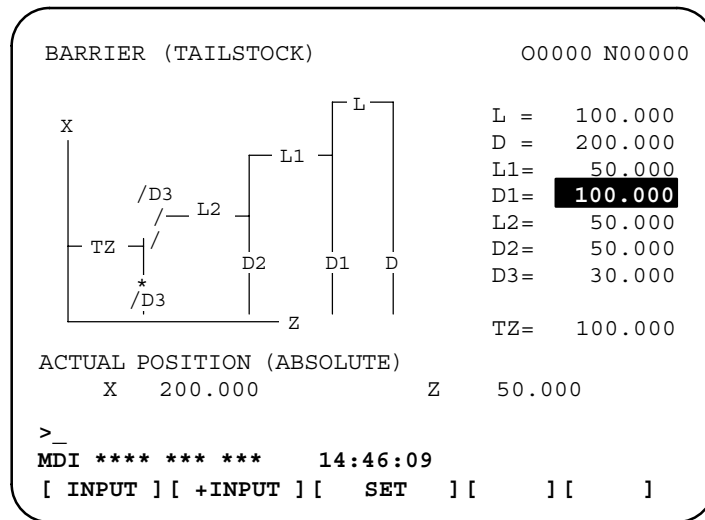

- 4 Position the cursor to each item defining the shape of the chuck or tailstock, enter the corresponding value, then press the **[INPUT]** soft key. The value is set. Pressing the **[+INPUT]** soft key after a value has been entered adds the entered value to the current value, the new setting being the sum of the two values.

Items CX and CZ, both on the chuck barrier setting screen, and item TZ on the tailstock barrier setting screen can also be set in another way. Manually move the tool to the desired position, then press the **[SET]** soft key to set the coordinate(s) of the tool in the workpiece coordinate system. If a tool having an offset other than 0 is manually moved to the desired position with no compensation applied, compensate for the tool offset in the set coordinate system.

Items other than CX, CZ, and TZ cannot be set by using the **[SET]** soft key.

Example)

When the tool tip enters the entry-inhibition area during machining, the function stops the movement of the tool and displays an alarm message. Since the machine system can stop only a slight delay after the CNC stops, the tool will actually stop moving at a point within the specified boundary. For safety, therefore, set an area a little larger than the determined area. The distance between the boundaries of these two areas, L, is calculated from the following equation, based on the rapid traverse rate.

$$L = (\text{Rapid traverse Rate}) \times \frac{1}{7500}$$

When the rapid traverse rate is 15 m/min, for example, set an area having a boundary 2 mm outside that of the determined area.

The shapes of the chuck and tailstock can be set using parameters No. 1330 to 1345.

CAUTION

Set G23 mode before attempting to specify the shapes of the chuck and tailstock.

● **Reference position return**

1 Return the tool to the reference position along the X- and Z-axes. The chuck-tailstock barrier function becomes effective only once reference position return has been completed after power on. When an absolute position detector is provided, reference position return need not always be performed. The positional relationship between the machine and the absolute position detector, however, must be determined.

● **G22, G23**

1 After reference position return, specifying G22 (stored stroke limit on) makes the entry-inhibition areas for the chuck and tailstock effective. Specifying G23 (stored stroke limit off) disables the function.

Even if G22 is specified, the entry-inhibition area for the tailstock can be disabled by issuing a tailstock barrier signal.

When the tailstock is pushed up against a workpiece or separated from the workpiece by using the miscellaneous functions, PMC signals are used to enable or disable the tailstock setting area.

G code	Tailstock barrier signal	Chuck barrier	Tailstock barrier
G22	0	Effective	Effective
	1	Effective	Ineffective
G23	No relation	Ineffective	Ineffective

G22 is usually selected when the power is turned on. Using G23, bit 7 of parameter No. 3402, however, it can be changed to G23.

Explanations

● **Setting the shape of the chuck barrier**

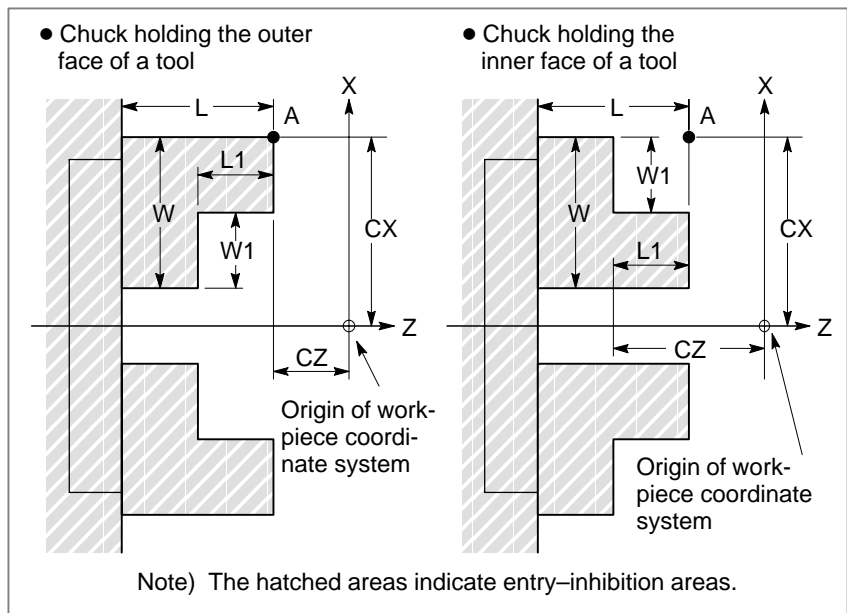

Symbol	Description
TY	Chuck-shapeselection (0: Holding the inner face of a tool, 1: Holding the outer face of a tool)
CX	Chuck position (along X-axis)
CZ	Chuck position (along Z-axis)
L	Length of chuck jaws
W	Depth of chuck jaws (radius)
L1	Holding length of chuck jaws
W1	Holding depth of chuck jaws (radius)

TY :

Selects a chuck type, based on its shape. Specifying 0 selects a chuck that holds the inner face of a tool. Specifying 1 selects a chuck that holds the outer face of a tool. A chuck is assumed to be symmetrical about its Z-axis.

CX, CZ:

Specify the coordinates of a chuck position, point A, in the workpiece coordinate system. These coordinates are not the same as those in the machine coordinate system. Table 6.4 (a) lists the units used to specify the data.

WARNING

Whether diameter programming or radius programming is used for the axis determines the programming system. When diameter programming is used for the axis, use diameter programming to enter data for the axis.

Table 6.4 (a) Units

Increment system	Data unit		Valid data range
	IS-A	IS-B	
Metric input	0.001 mm	0.0001 mm	-99999999 to +99999999
Inch input	0.0001 inch	0.00001 inch	-99999999 to +99999999

L, L1, W, W1:

Define the shape of a chuck. Table 6.4 (b) lists the units used to specify the data.

WARNING

Always specify W and W1 in radius. When radius programming is used for the Z-axis, specify L and L1 in radius.

Table 6.4 (b) Units

Increment system	Data unit		Valid data range
	IS-A	IS-B	
Metric input	0.001 mm	0.0001 mm	-99999999 to +99999999
Inch input	0.0001 inch	0.00001 inch	-99999999 to +99999999

● **Setting the shape of a tailstock barrier**

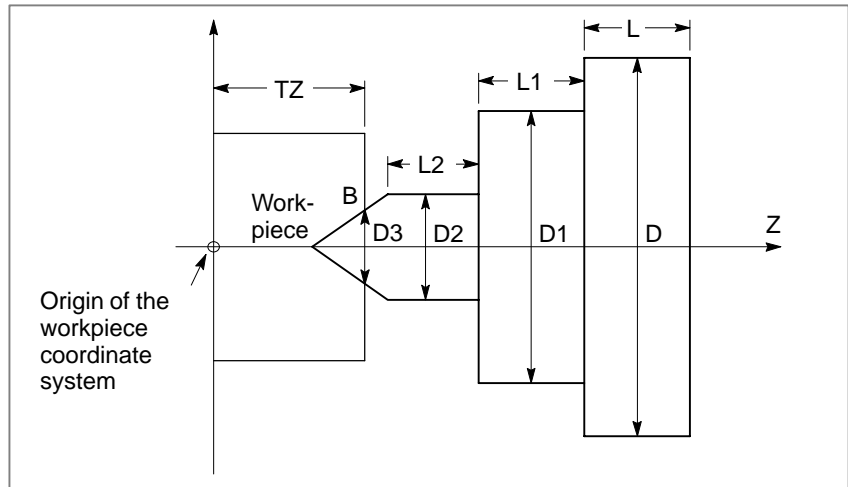

Symbol	Description
TZ	Tailstock position (along the Z-axis)
L	Tailstock length
D	Tailstock diameter
L1	Tailstock length (1)
D1	Tailstock diameter (1)
L2	Tailstock length (2)
D2	Tailstock diameter (2)
D3	Tailstock diameter (3)

TZ :

Specifies the Z coordinate of the chuck position, point B, in the workpiece coordinate system. These coordinates are not the same as those in the machine coordinate system. Table 6.4 (c) lists the units used to specify the data. A tailstock is assumed to be symmetrical about its Z-axis.

WARNING

Whether diameter programming or radius programming is used for the Z-axis determines the programming system.

Table 6.4 (c) Units

Increment system	Data unit		Valid data range
	IS-A	IS-B	
Metric input	0.001 mm	0.0001 mm	-99999999 to +99999999
Inch input	0.0001 inch	0.00001 inch	-99999999 to +99999999

L, L1, L2, D, D1, D2, D3:

Define the shape of a tailstock. Table 6.4 (d) lists the units used to specify the data.

WARNING

Always specify D, D1, D2, and D3 in diameter programming. When radius programming is used for the Z-axis, specify L, L1, and L2 in radius.

Table 6.4 (d) Units

Increment system	Data unit		Valid data range
	IS-A	IS-B	
Metric input	0.001 mm	0.0001 mm	-99999999 to +99999999
Inch input	0.0001 inch	0.00001 inch	-99999999 to +99999999

- **Setting the entry-inhibition area for the tailstock tip**

The tip angle of the tailstock is 60 degrees. The entry-inhibition area is set around the tip, assuming the angle to be 90 degrees, as shown below.

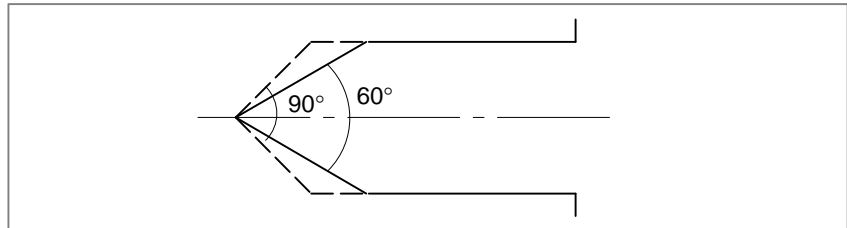

Limitations

- **Correct setting of an entry-inhibition area**
- **Retraction from the entry-inhibition area**

If an entry-inhibition area is incorrectly set, it may not be possible to make the area effective. Avoid making the following settings:

- $L < L1$ or $W < W1$ in the chuck-shape settings.
- $D2 < D3$ in the tailstock-shape settings.
- A chuck setting overlapping that of the tailstock.

If the tool enters the entry-inhibition area and an alarm is issued, switch to manual mode, retract the tool manually, then reset the system to release the alarm. In manual mode, the tool can be moved only in the opposite direction to that in which the tool entered the area. The tool cannot be moved in the same direction (further into the area) as it was travelling when the tool entered the area.

When the entry-inhibition areas for the chuck and tailstock are enabled, and the tool is already positioned within those areas, an alarm is issued when the tool moves. When the tool cannot be retracted, change the setting of the entry-inhibition areas, such that the tool is outside the areas, reset the system to release the alarm, then retract the tool. Finally, reinstall the original settings.

• Coordinate system

An entry-inhibition area is defined using the workpiece coordinate system. Note the following.

- 1 When the workpiece coordinate system is shifted by means of a command or operation, the entry-inhibition area is also shifted by the same amount.

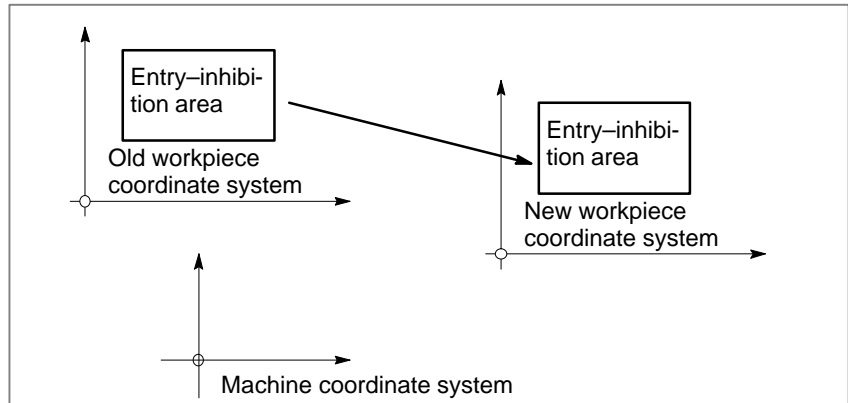

Use of the following commands and operations will shift the workpiece coordinate system.

Commands:

G54 to G59, G52, G50 (G92 in G code system B or C)

Operations:

Manual handle interrupt, change in offset relative to the workpiece reference point, change in tool offset (tool geometry compensation), operation with machine lock, manual operation with machine absolute signal off

- 2 When the tool enters an entry-inhibition area during automatic operation, set the manual absolute signal, *ABSM, to 0 (on), then manually retract the tool from the area. If this signal is 1, the distance the tool moves in manual operation is not counted in the tool coordinates in the workpiece coordinate system. This results in the state where the tool can never be retracted from the entry-inhibition area.

• Stored stroke limit 2

When both stored stroke limit 2 and the chuck-tailstock barrier function are provided, the barrier takes priority over the stroke limit. Stored stroke limit 2 is ignored.

Alarms

Number	Message	Contents
502	OVER TRAVEL: +X	The tool has entered the entry-inhibition area during positive-direction movement along the X-axis.
	OVER TRAVEL: +Z	The tool has entered the entry-inhibition area during positive-direction movement along the Z-axis.
503	OVER TRAVEL: -X	The tool has entered the entry-inhibition area during negative-direction movement along the X-axis.
	OVER TRAVEL: -Z	The tool has entered the entry-inhibition area during negative-direction movement along the Z-axis.

6.5 STROKE LIMIT CHECK PRIOR TO PERFORMING MOVEMENT

During automatic operation, before the movement specified by a given block is started, whether the tool enters the inhibited area defined by stored stroke limit 1, 2, or 3 is checked by determining the position of the end point from the current position of the machine and a specified amount of travel. If the tool is found to enter the inhibited area defined by a stored stroke limit, the tool is stopped immediately upon the start of movement for that block, and an alarm is displayed.

WARNING

Whether the coordinates of the end point, reached as a result of traversing the distance specified in each block, are in a inhibited area is checked. In this case, the path followed by a move command is not checked. However, if the tool enters the inhibited area defined by stored stroke limit 1, 2, or 3, an alarm is issued. (See the examples below.)

Example 1)

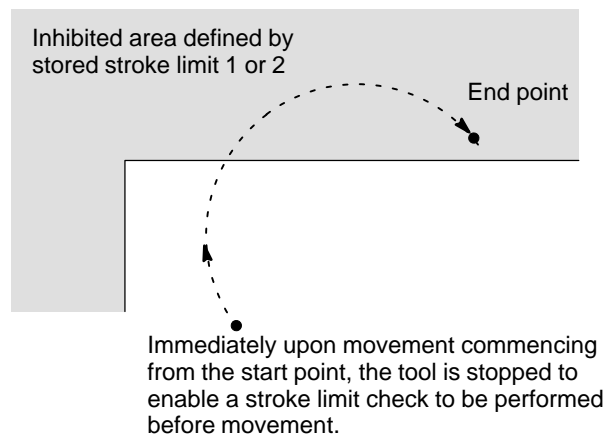
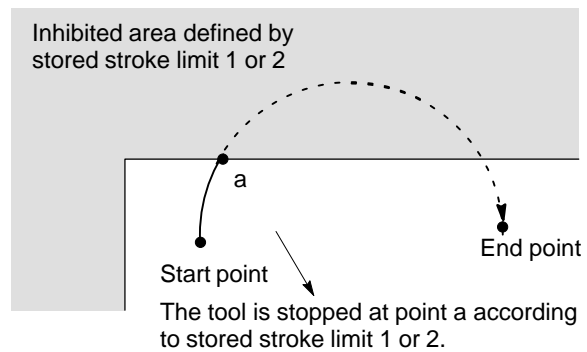

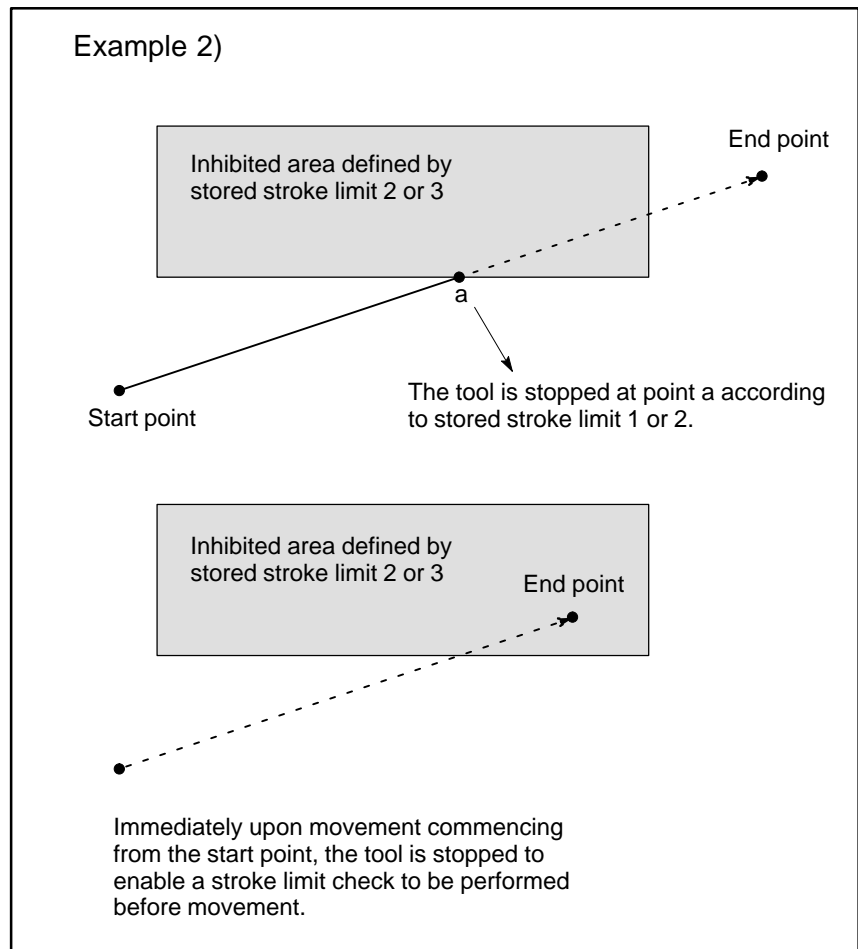

Explanations

When a stroke limit check prior to movement is performed, whether to check the movement performed by a G31 (skip) block and G37 (automatic tool length measurement) block can be determined using NPC (bit 2 of parameter No. 1301).

Limitations

- **Machine lock**

If machine lock is applied at the start of movement, no stroke limit check made before movement is performed.
- **G23**

When stored stroke limit 2 is disabled (G23 mode), no check is made to determine whether the tool enters the inhibited area defined by stored stroke limit 2.
- **Program restart**

When a program is restarted, an alarm is issued if the restart position is within a inhibited area.
- **Manual intervention following a feed hold stop**

When the execution of a block is restarted after manual intervention following a feed hold stop, no alarm is issued even if the end point after manual intervention is within a inhibited area.
- **A block consisting of multiple operations**

If a block consisting of multiple operations (such as a canned cycle and exponential interpolation) is executed, an alarm is issued at the start point of any operation whose end point falls within a inhibited area.

- **Cylindrical interpolation mode** In cylindrical interpolation mode, no check is made.
- **Polar coordinate interpolation mode** In polar coordinate interpolation mode, no check is made.
- **Slanted axis control** When the slanted axis control option is selected, no check is made.
- **Simple synchronous control** In simple synchronous control, only the master axis is checked; no slave axes are checked.
- **Drawing** During drawing (while only drawing (no machining) is being performed), no check is made.
- **PMC axis control** No check is made for a movement based on PMC axis control.
- **Chuck/tailstock barrier** No check is made for a chuck/tailstock barrier area (lathe system).
- **Synchronous mixed mode** No check is made for an axis placed in synchronous mixed mode (two-path lathe control).

Alarm

Number	Message	Contents
506	OVER TRAVEL : +n	The pre-movement stroke limit check reveals that the block end point enters the prohibited area for the positive stroke limit along the n axis. Correct the program.
507	OVER TRAVEL : -n	The pre-movement stroke limit check reveals that the block end point enters the prohibited area for the negative stroke limit along the n axis. Correct the program.

7

ALARM AND SELF-DIAGNOSIS FUNCTIONS



When an alarm occurs, the corresponding alarm screen appears to indicate the cause of the alarm. The causes of alarms are classified by error codes. Up to 25 previous alarms can be stored and displayed on the screen (alarm history display).

The system may sometimes seem to be at a halt, although no alarm is displayed. In this case, the system may be performing some processing. The state of the system can be checked using the self-diagnostic function.

7.1 ALARM DISPLAY

Explanations

- **Alarm screen**

When an alarm occurs, the alarm screen appears.

```

ALARM MESSAGE                                O0000 00000

100  PARAMETER WRITE ENABLE
510  OVER TRAVEL  :+X
520  OVER TRAVEL  :+2
530  OVER TRAVEL  :+3

MDI ***** *ALM* 18:52:05 S 0 T0000
( [ALARM] ) ( MSG ) ( HISTRY ) ( ) ( )
    
```

- **Another method for alarm displays**

In some cases, the alarm screen does not appear, but an ALM is displayed at the bottom of the screen.

```

PARAMETER (RS232C INTERFACE)                 O1000 N00010

0100  ENS                NCR                CTV
      0  0  0  0  0  0  0  0
0101  NFD                ASI                SB2
      0  0  0  0  0  0  0  1
0102  DEVICE NUM. (CH0)
0103  BAUDRATE (CH0)
0111  NFD                ASI                SB2
      0  0  0  0  0  0  0  0
0112  DEVICE NUM. (CH1)
0113  BAUDRATE (CH1)

>_ MEM ***** *ALM* 08:41:27 S 0 T0000
( [NO.SRH] ) ( ON:1 ) ( OFF:0 ) ( +INPUT ) ( INPUT )
    
```

In this case, display the alarm screen as follows:

- 1 Press the function key  .
- 2 Press the chapter selection soft key [ALARM].

- **Reset of the alarm**

Error codes and messages indicate the cause of an alarm. To recover from an alarm, eliminate the cause and press the reset key.

- **Error codes**

The error codes are classified as follows:

No. 000 to 255: P/S alarms (Program errors)*1

No. 300 to 349: Absolute pulse coder (APC) alarms

No. 350 to 399: Serial pulse coder (SPC) alarms

No. 400 to 499: Servo alarms

No. 500 to 599: Overtravel alarms

No. 700 to 749: Overheat alarms

No. 750 to 799: Spindle alarms

No. 900 to 999: System alarms

No. 5000 to : P/S alarms (Program errors)

*1:For an alarm (No. 000 to 232) that occurs in association with background operation, the indication “xxxBP/S alarm” is provided (where xxx is an alarm number). Only a BP/S alarm is provided for No. 140.



See the error code list in the Appendix G for details of the error codes.

7.2 ALARM HISTORY DISPLAY

Up to 25 of the most recent CNC alarms are stored and displayed on the screen.

Display the alarm history as follows:

Procedure for Alarm History Display

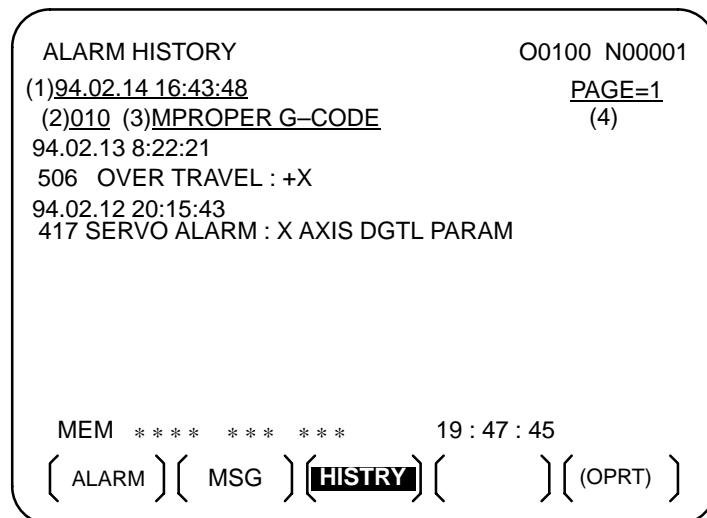

- 1 Press the function key 
- 2 Press the chapter selection soft key **[HISTRY]**.
The alarm history appears.
The following information items are displayed.
 - (1)The date the alarm was issued
 - (2)Alarm No.
 - (3)Alarm message (some contains no message)
 - (4)Page number
- 3 Change the page by page key  or .
- 4 To delete the recorded information, press the softkey **[(OPRT)]** then the **[DELETE]** key.



7.3 CHECKING BY SELF-DIAGNOSTIC SCREEN

The system may sometimes seem to be at a halt, although no alarm has occurred. In this case, the system may be performing some processing. The state of the system can be checked by displaying the self-diagnostic screen.

Procedure for Diagnostic

- 1 Press the function key  .
- 2 Press the chapter select key **[DGNOS]**.
- 3 The diagnostic screen has more than 1 pages. Select the screen by the following operation.
 - (1) Change the page by page key  or  .
 - (2) Method by soft key
 - Key input the number of the diagnostic data to be displayed.
 - Press **[N SRCH]**.

```

DIAGNOSTIC (GENERAL)                O0000 N00000

000 WAITING FOR FIN SIGNAL           :0
001 MOTION                           :0
002 DWELL                            :0
003 IN-POSITION CHECK                :0
004 FEEDRATE OVERRIDE 0%             :0
005 INTERLOCK/START-LOCK             :0
006 SPINDLE SPEED ARRIVAL CHECK      :0

)_

EDIT ***** 14 : 51 : 55
( PARAM ) ( DGNOS ) ( PMC ) ( SYSTEM ) ( OPRT )
  
```

Explanations

- **Self diagnostic screen at 2-path control**

For the two-path control, the diagnostic screen for the tool post selected with the tool post selection switch is displayed. When displaying the diagnostic screen for the other tool post, specify the tool post with the tool post selection switch.

Explanations

Diagnostic numbers 000 to 015 indicate states when a command is being specified but appears as if it were not being executed. The table below lists the internal states when 1 is displayed at the right end of each line on the screen.

Table 7.3 (a) Alarm displays when a command is specified but appears as if it were not being executed

No.	Display	Internal status when 1 is displayed
000	WAITING FOR FIN SIGNAL	M, S, T function being executed
001	MOTION	Move command in automatic operation being executed
002	DWELL	Dwell being executed
003	IN-POSITION CHECK	In-position check being executed
004	FEEDRATE OVERRIDE 0%	Cutting feed override 0%
005	INTERLOCK/START-LOCK	Interlock ON
006	SPINDLE SPEED ARRIVAL CHECK	Waiting for spindle speed arrival signal to turn on
010	PUNCHING	Data being output via reader puncher interface
011	READING	Data being input via reader puncher interface
012	WAITING FOR (UN) CLAMP	Waiting for index table clamp/unclamp before B axis index table indexing start/after B axis index table indexing end to complete
013	JOG FEEDRATE OVERRIDE 0%	Jog override 0%
014	WAITING FOR RESET.ESP.RRW.OFF	Emergency stop, external reset, reset & rewind, or MDI panel reset key on
015	EXTERNAL PROGRAM NUMBER SEARCH	External program number searching

Diagnostic numbers 020 to 025 indicate the states when automatic operation is stopped or paused.

Table 7.3 (b) Alarm displays when an automatic operation is stopped or paused

No.	Display	Internal status when 1 is displayed
020	CUT SPEED UP/DOWN	Set when emergency stop turns on or when servo alarm occurs
021	RESET BUTTON ON	Set when reset key turns on
022	RESET AND REWIND ON	Reset and rewind turned on
023	EMERGENCY STOP ON	Set when emergency stop turns on
024	RESET ON	Set when external reset, emergency stop, reset, or reset & rewind key turns on
025	STOP MOTION OR DWELL	A flag which stops pulse distribution. It is set in the following cases. (1)External reset turned on. (2)Reset & rewind turned on. (3)Emergency stop turned on. (4)Feed hold turned on. (5)The MDI panel reset key turned on. (6)Switched to the manual mode(JOG/HANDLE/INC). (7)Other alarm occurred. (There is also alarm which is not set.)

The table below shows the signals and states which are enabled when each diagnostic data item is 1. Each combination of the values of the diagnostic data indicates a unique state.

020	CUT SPEED UP/DOWN	1	0	0	0	1	0	0
021	RESET BUTTON ON	0	0	1	0	0	0	0
022	RESET AND REWIND ON	0	0	0	1	0	0	0
023	EMERGENCY STOP ON	1	0	0	0	0	0	0
024	RESET ON	1	1	1	1	0	0	0
025	STOP MOTION OR DWELL	1	1	1	1	1	1	0

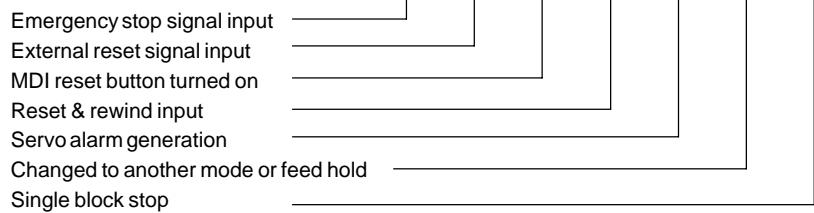

Diagnostic numbers 030 and 031 indicate TH alarm states.

No.	Display	Meaning of data
030	CHARACTER NUMBER TH DATA	The position of the character which caused TH alarm is displayed by the number of characters from the beginning of the block at TH alarm
031	TH DATA	Read code of character which caused TH alarm

8 DATA INPUT/OUTPUT

NC data is transferred between the CNC and external input/output devices such as the Handy File.

The following types of data can be entered and output :

1. Program
2. Offset data
3. Parameter
4. Pitch error compensation data
5. Custom macro common variable

Before an input/output device can be used, the input/output related parameters must be set.

For how to set parameters, see Chapter III-2.

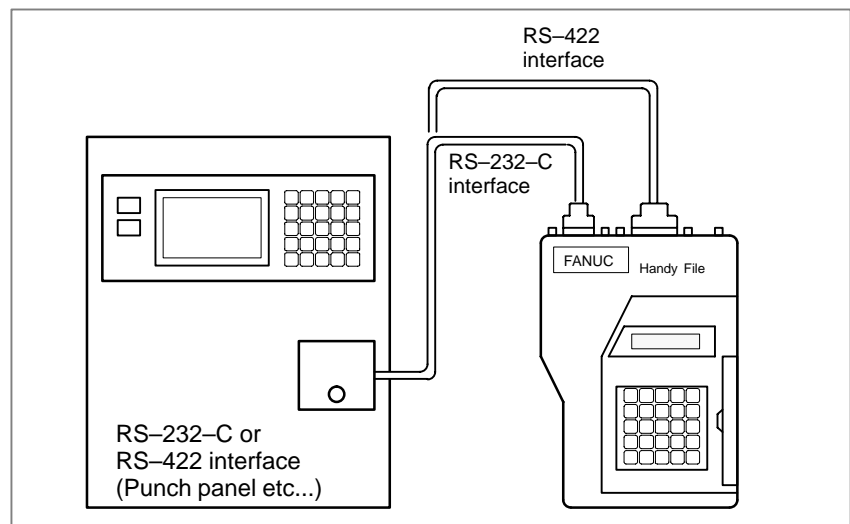

8.1 FILES

Of the external input/output devices, the FANUC Handy File use floppy disks as their input/output medium.

In this manual, an input/output medium is generally referred to as a floppy.

Unlike an NC tape, a floppy allows the user to freely choose from several types of data stored on one medium on a file-by-file basis.

Input/output is possible with data extending over more than one floppy disk.

Explanations

- **What is a File**

The unit of data, which is input/output between the floppy and the CNC by one input/output operation (pressing the VREADW or VPUNCHW key), is called a HfileI. When inputting CNC programs from, or outputting them to the floppy, for example, one or all programs within the CNC memory are handled as one file.

Files are assigned automatically file numbers 1, 2, 3, 4 and so on, with the lead file as 1.

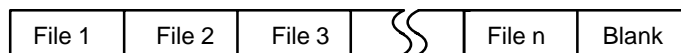

- **Request for floppy replacement**

When one file has been entered over two floppies, LEDs on the adaptor flash alternately on completion of data input/output between the first floppy and the CNC, prompting floppy replacement. In this case, take the first floppy out of the adaptor and insert a second floppy in its place. Then, data input/output will continue automatically.

Floppy replacement is prompted when the second floppy and later is required during file search-out, data input/output between the CNC and the floppy, or file deletion.

Floppy 1

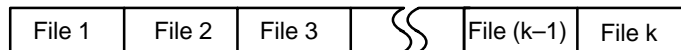

Floppy 2

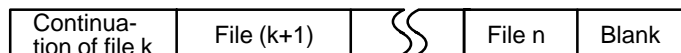

Since floppy replacement is processed by the input/output device, no special operation is required. The CNC will interrupt data input/output operation until the next floppy is inserted into the adaptor.

When reset operation is applied to the CNC during a request for floppy replacement, the CNC is not reset at once, but reset after the floppy has been replaced.

- **Protect switch**

The floppy is provided with the write protect switch. Set the switch to the write enable state. Then, start output operation.

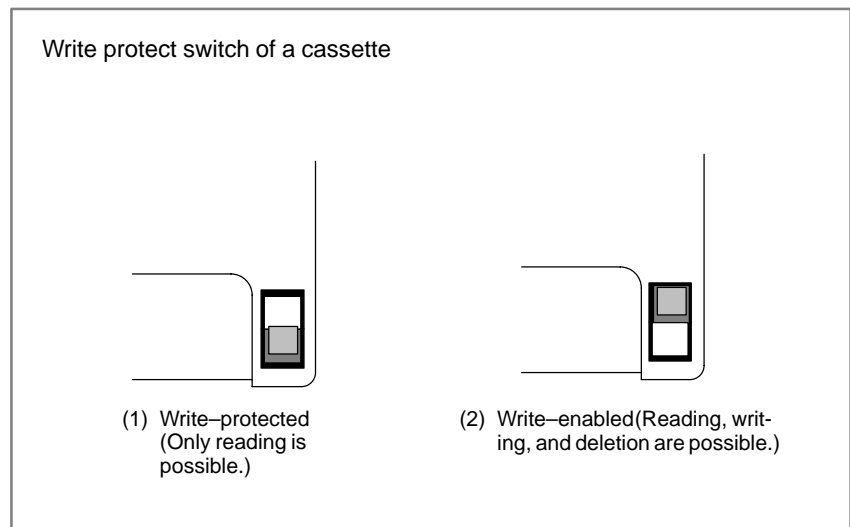

Fig. 8.1 Protect switch

- **Writing memo**

Once written in the cassette or card, data can subsequently be read out by correspondence between the data contents and file numbers. This correspondence cannot be verified, unless the data contents and file numbers are output to the CNC and displayed. The data contents can be displayed with display function for directory of floppy disk (See Section III-8.8).

To display the contents, write the file numbers and the contents on the memo column which is the back of floppy.

(Entry example on MEMO)

File 1 NC parameters

File 2 Offset data

File 3 NC program O0100

...

...

...

File (n-1) NC program O0500

File n NC program O0600

8.2 FILE SEARCH

When the program is input from the floppy, the file to be input first must be searched.

For this purpose, proceed as follows:

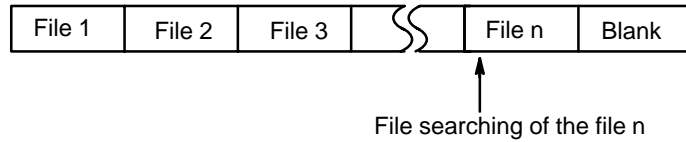

Procedure for File Heading

- 1 Press the EDIT or MEMORY switch on the machine operator's panel.
- 2 Press function key PROG, then the program contents display screen or program check screen appears.
- 3 Press soft key **[(OPRT)]**
- 4 Press the rightmost soft key ▷ (next-menu key).
- 5 Enter address N.
- 6 Enter the number of the file to search for.
 - N0
The beginning of the cassette or card is searched.
 - One of N1 to N9999
Of the file Nos. 1 to 9999, a designated file is searched.
 - N-9999
The file next to that accessed just before is searched.
 - N-9998
When N-9998 is designated, N-9999 is automatically inserted each time a file is input or output. This condition is reset by the designation of N1, N1 to 9999, or N-9999 or reset.
- 7 Press soft keys **[FSRH]** and **[EXEC]**
The specified file is searched for.

Explanations

- **File search by N-9999**

The same result is obtained both by sequentially searching the files by specifying Nos. N1 to N9999 and by first searching one of N1 to N9999 and then using the N-9999 searching method. The searching time is shorter in the latter case.



Alarm

No.	Description
86	<p>The ready signal (DR) of an input/output device is off.</p> <p>An alarm is not immediately indicated in the CNC even when an alarm occurs during head searching (when a file is not found, or the like).</p> <p>An alarm is given when the input/output operation is performed after that. This alarm is also raised when N1 is specified for writing data to an empty floppy. (In this case, specify N0.)</p>

8.3 FILE DELETION

Files stored on a floppy can be deleted file by file as required.

Procedure for File Deletion

- 1 Insert the floppy into the input/output device so that it is ready for writing.
- 2 Press the EDIT switch on the machine operator's panel.
- 3 Press function key , then the program contents display screen appears.
- 4 Press soft key **[(OPRT)]**
- 5 Press the rightmost soft key  (next-menu key).
- 6 Enter address N.
- 7 Enter the number (from 1 to 9999) of the file to delete.
- 8 Press soft key **[DELETE]**, then press soft key **[EXEC]**.
The file specified in step 7 is deleted.

Explanations

- **File number after the file is deleted**

When a file is deleted, the file numbers after the deleted file are each decremented by one. Suppose that a file numbered k was deleted. In this case, files are renumbered as follows:

Before deletion	...	after deletion
1 to (k-1)	1 to (k-1)
k	Deleted
(k+1) to n	k to (n-1)

- **Protect switch**



Set the write protect switch to the write enable state to delete the files.

8.4 PROGRAM INPUT/OUTPUT

8.4.1 Inputting a Program

This section describes how to load a program into the CNC from a floppy or NC tape.

Procedure for Inputting a Program

- 1 Make sure the input device is ready for reading.
For the two-path control, select the tool post for which a program to be input is used with the tool post selection switch.
- 2 Press the EDIT switch on the machine operator's panel.
- 3 When using a floppy, search for the required file according to the procedure in Section III-8.2.
- 4 Press function key , then the program contents display screen or program directory screen appears.
- 5 Press soft key **[(OPRT)]**
- 6 Press the rightmost soft key  (next-menu key).
- 7 After entering address O, specify a program number to be assigned to the program. When no program number is specified here, the program number used on the floppy or NC tape is assigned.
- 8 Press soft keys **[READ]** and **[EXEC]**
The program is input and the program number specified in step 7 is assigned to the program.

Explanations

- **Collation**

If a program is input while the data protect key on the machine operator's panel turns ON, the program loaded into the memory is verified against the contents of the floppy or NC tape.

If a mismatch is found during collation, the collation is terminated with an P/S alarm (No. 79).

If the operation above is performed with the data protection key turns OFF, collation is not performed, but programs are registered in memory.

- **Inputting multiple programs from an NC tape**

When a tape holds multiple programs, the tape is read up to ER (or %).

O1111- - - - - M02;	O2222 - - - M30;	O3333- - - - M02;	ER(%)
---------------------	------------------	-------------------	-------

● **Program numbers on a NC tape**

- When a program is entered without specifying a program number.
- The O-number of the program on the NC tape is assigned to the program. If the program has no O-number, the N-number in the first block is assigned to the program.
- When the program has neither an O-number nor N-number, the previous program number is incremented by one and the result is assigned to the program.
- When the program does not have an O-number but has a five-digit sequence number at the start of the program, the lower four digits of the sequence number are used as the program number. If the lower four digits are zeros, the previously registered program number is incremented by one and the result is assigned to the program.
- When a program is entered with a program number
The O-number on the NC tape is ignored and the specified number is assigned to the program. When the program is followed by additional programs, the first additional program is given the program number. Additional program numbers are calculated by adding one to the last program.

● **Program registration in the background**

The method of registration operation is the same as the method of foreground operation. However, this operation registers a program in the background editing area. As with edit operation, the operations described below are required at the end to register a program in foreground program memory.

[(OPRT)] [BG-END]

● **Additional program input**

You can input a program to be appended to the end of a registered program.

Registered program	Input program	Program after input
○1234 ;	○5678 ;	○1234 ;
□□□□□□□ ;	○○○○○○○○ ;	□□□□□□□ ;
□□□□□ ;	○○○○○ ;	□□□□□ ;
□□□□ ;	○○○○ ;	□□□□ ;
□□□ ;	○○○ ;	□□□ ;
%	%	%
		○5678 ;
		○○○○○○○○ ;
		○○○○○ ;
		○○○○ ;
		○○○ ;
		%

In the above example, all lines of program O5678 are appended to the end of program O1234. In this case, program number O5678 is not registered. When inputting a program to be appended to a registered program, press the **[READ]** soft key without specifying a program number in step 8. Then, press the **[CHAIN]** and **[EXEC]** soft keys.

- In entire program input, all lines of a program are appended, except for its O number.
- When canceling additional input mode, press the reset key or the **[CAN]** or **[STOP]** soft key.
- Pressing the **[CHAIN]** soft key positions the cursor to the end of the registered program. Once a program has been input, the cursor is positioned to the start of the new program.

- **Defining the same program number as that of an existing program**
Additional input is possible only when a program has already been registered.
If an attempt has been made to register a program having the same number as that of a previously registered program, P/S alarm 073 is issued and the program cannot be registered.



Alarm

No.	Description
70	The size of memory is not sufficient to store the input programs
73	An attempt was made to store a program with an existing program number.
79	The verification operation found a mismatch between a program loaded into memory and the contents of the program on the floppy or NC tape.

8.4.2 Outputting a Program

A program stored in the memory of the CNC unit is output to a floppy or NC tape.

Procedure for Outputting a Program

- 1 Make sure the output device is ready for output.
For the two-path control, select the tool post for which a program to be output is used with the tool post selection switch.
- 2 To output to an NC tape, specify the punch code system (ISO or EIA) using a parameter.
- 3 Press the EDIT switch on the machine operator's panel.
- 4 Press function key , then the program contents display screen or program directory screen appears.
- 5 Press soft key **[(OPRT)]**.
- 6 Press the rightmost soft key  (next-menu key).
- 7 Enter address O.
- 8 Enter a program number. If -9999 is entered, all programs stored in memory are output.
To output multiple programs at one time, enter a range as follows :
OΔΔΔΔ,O□□□□
Programs No. ΔΔΔΔ to No. □□□□ are output.
The program library screen displays program numbers in ascending order when bit 4 (SOR) of parameter No. 3107 is set to 1.
- 9 Press soft keys **[PUNCH]** and **[EXEC]**
The specified program or programs are output.

Explanations (Output to a floppy)

- **File output location**
When output is conducted to the floppy, the program is output as the new file after the files existing in the floppy. New files are to be written from the beginning with making the old files invalid, use the above output operation after the N0 head searching.
- **An alarm while a program is output**
When P/S alarm (No. 086) occurs during program output, the floppy is restored to the condition before the output.
- **Outputting a program after file heading**
When program output is conducted after N1 to N9999 head searching, the new file is output as the designated n-th position. In this case, 1 to n-1 files are effective, but the files after the old n-th one are deleted. If an alarm occurs during output, only the 1 to n-1 files are restored.
- **Efficient use of memory**
To efficiently use the memory in the cassette or card, output the program by setting parameter NFD (No. 0101#7, No. 0111#7 or 0121#7) to 1. This parameter makes the feed is not output, utilizing the memory efficiently.

- **On the memo record**

Head searching with a file No. is necessary when a file output from the CNC to the floppy is again input to the CNC memory or compared with the content of the CNC memory. Therefore, immediately after a file is output from the CNC to the floppy, record the file No. on the memo.

- **Punching programs in the background**

Punch operation can be performed in the same way as in the foreground. This function alone can punch out a program selected for foreground operation.

<O> (Program No.) **[PUNCH] [EXEC]**: Punches out a specified program.
 <O> H-9999I **[PUNCH] [EXEC]**: Punches out all programs.

**Explanations
 (Output to an NC tape)**

- **Format**

A program is output to paper tape in the following format:

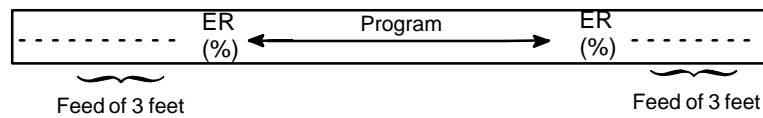

If three-foot feeding is too long, press the key during feed punching to cancel the subsequent feed punching.

- **TV check**

A space code for TV check is automatically punched.

- **ISO code**

When a program is punched in ISO code, two CR codes are punched after an LF code.



By setting NCR (bit 3 of parameter No. 0100), CRs can be omitted so that each LF appears without a CR.

- **Stopping the punch**

Press the key to stop punch operation.

- **Punching all programs**

All programs are output to paper tape in the following format.

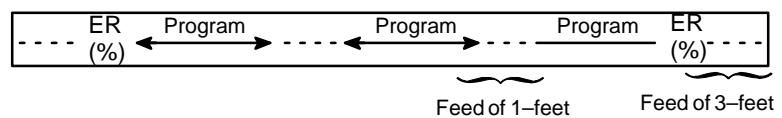



The sequence of the programs punched is undefined.

8.5 OFFSET DATA INPUT AND OUTPUT

8.5.1 Inputting Offset Data

Offset data is loaded into the memory of the CNC from a floppy or NC tape. The input format is the same as for offset value output. See section III-8.5.2. When an offset value is loaded which has the same offset number as an offset number already registered in the memory, the loaded offset data replaces existing data.



Procedure for Inputting Offset Data

- 1 Make sure the input device is ready for reading
For the two-path control, select the tool post for which offset data to be input is used with the tool post selection switch.
- 2 Press the EDIT switch on the machine operator's panel.
- 3 When using a floppy, search for the required file according to the procedure in Section III-8.2.
- 4 Press function key  to display tool offset screen.
- 5 Press soft keys **[(OPRT)]**, then the tool compensation screen appears.
- 6 Press rightmost soft key  (next menu key).
- 7 Press soft keys **[READ]** and **[EXEC]**.
- 8 The input offset data will be displayed on the screen after completion of input operation.

8.5.2 Outputting Offset Data

All offset data is output in a output format from the memory of the CNC to a floppy or NC tape.

Procedure for Outputting Offset Data

- 1 Make sure the output device is ready for output.
For the two-path control, select the tool post for which offset data to be output is used with the tool post selection switch.
- 2 Specify the punch code system (ISO or EIA) using a parameter.
- 3 Press the EDIT switch on the machine operator's panel.
- 4 Press function key  to display tool offset screen.
- 5 Press soft key **[(OPRT)]**.
- 6 Press the rightmost soft key  (next-menu key)
- 7 Press soft keys **[PUNCH]** and **[EXEC]**.
Offset data is output in the output format described below.

Explanations

- **Output format**

Output format is as follows:

Format

G10P_X_Y_Z_R_Q_;

P: Offset number

... Work sheet : P=0

... For wear offset amount : P=Wear offset number

... For geometry offset amount : p=10000+geometry offset number

X:Offset value on X axis

Y: Offset value on Y axis

Z:Offset value on Z axis

Q:Imaginary tool nose number

R:Tool nose radius offset value

The L1 command may be used instead of L11 for format compatibility of the conventional CNC.

- **Output file name**

When the floppy disk directory display function is used, the name of the output file is OFFSET.





8.6 INPUTTING AND OUTPUTTING PARAMETERS AND PITCH ERROR COMPENSATION DATA

Parameters and pitch error compensation data are input and output from different screens, respectively. This chapter describes how to enter them.

8.6.1 Inputting Parameters

Parameters are loaded into the memory of the CNC unit from a floppy or NC tape. The input format is the same as the output format. See Subsec. III-8.6.2. When a parameter is loaded which has the same data number as a parameter already registered in the memory, the loaded parameter replaces the existing parameter.

Procedure for Inputting Parameters



- 1 Make sure the input device is ready for reading.
For the two-path control, select the tool post for which parameters to be input are used with the tool post selection switch.
- 2 When using a floppy, search for the required file according to the procedure in Section III-8.2.
- 3 Press the EMERGENCY STOP button on the machine operator's panel.
- 4 Press function key  .
- 5 Press the soft key **[SETTING]** for chapter selection, then the setting screen appears.
- 6 Enter 1 in response to the prompt for "PARAMETER WRITE (PWE)" in setting data. P/S alarm (No. 100 (indicating that parameters can be written)) appears.
- 7 Press soft key  .
- 8 Press chapter selection soft key **[PARAM]**, then the parameter screen appears.
- 9 Press soft key **[(OPRT)]**.
- 10 Press the rightmost soft key  (next-menu key).
- 11 Press soft keys **[READ]** and **[EXEC]**.
Parameters are read into memory. Upon completion of input, the "INPUT" indicator at the lower-right corner of the screen disappears.
- 12 Press function key  .
- 13 Press soft key **[SETTING]** for chapter selection.
- 14 Enter 0 in response to the prompt for "PARAMETER WRITE (PWE)" in setting data.

- 15 Turn the power to the NC back on.
- 16 Release the EMERGENCY STOP button on the machine operator's panel.

8.6.2 Outputting Parameters

All parameters are output in the defined format from the memory of the CNC to a floppy or NC tape.

Procedure for Outputting Parameters

- 1 Make sure the output device is ready for output.
For the two-path control, select the tool post for which parameters to be input are used with the tool post selection switch.
- 2 Specify the punch code system (ISO or EIA) using a parameter.
- 3 Press the EDIT switch on the machine operator's panel.
- 4 Press function key  .
- 5 Press chapter selection soft key **[PARAM]** to display the parameter screen.
- 6 Press soft key **[(OPRT)]**.
- 7 Press rightmost soft key  (next-menu key).
- 8 Press soft key **[PUNCH]**.
- 9 To output all parameters, press the **[ALL]** soft key. To output only parameters which are set to other than 0, press the **[NON-0]** soft key.
- 10 Press soft key **[EXEC]**.
All parameters are output in the defined format.

Explanations

- **Output format**

Output format is as follows:

N.. P .. ;
N.. A1P ... A2P ... AnP .. ;
N.. P .. ;

N:Parameter No.

A:Axis No. (n is the number of control axis)

P:Parameter setting value .

- **Suppressing output of parameters set to 0**

To suppress the output of the following parameters, press the **[PUNCH]** soft key then **[NON-0]** soft key.

	Other than axis type	Axis type
Bit type	Parameter for which all bits are set to 0	Parameter for an axis for which all bits are set to 0.
Value type	Parameter whose value is 0.	Parameter for an axis for which the value is 0.

- **Output file name**





When the floppy disk directory display function is used, the name of the output file is PARAMETER.

Once all parameters have been output, the output file is named ALL PARAMETER. Once only parameters which are set to other than 0 have been output, the output file is named NON-0. PARAMETER.

8.6.3 Inputting Pitch Error Compensation Data

Pitch error compensation data are loaded into the memory of the CNC from a floppy or NC tape. The input format is the same as the output format. See Section 8.6.4. When a pitch error compensation data is loaded which has the corresponding data number as a pitch error compensation data already registered in the memory, the loaded data replaces the existing data.

Procedure for Pitch Error Compensation Data

- 1 Make sure the input device is ready for reading.
For the two-path control, select the tool post for which pitch error compensation data to be input is used with the tool post selection switch.
- 2 When using a floppy, search for the required file according to the procedure in Section III-8.2.
- 3 Press the EMERGENCY STOP button on the machine operator's panel.
- 4 Press function key  .
- 5 Press the soft key **[SETTING]** for chapter selection.
- 6 Enter 1 in response to the prompt for "PARAMETER WRITE (PWE)" in setting data. P/S alarm (No. 100 (indicating that parameters can be written)) appears.
- 7 Press soft key  .
- 8 Press the rightmost soft key  (next-menu key) and press chapter selection soft key **[PITCH]**.
- 9 Press soft key **[(OPRT)]**.
- 10 Press the rightmost soft key  (next-menu key).
- 11 Press soft keys **[READ]** and **[EXEC]**.
Pitch error compensation data are read into memory. Upon completion of input, the "INPUT" indicator at the lower-right corner of the screen disappears.
- 12 Press function key  .
- 13 Press soft key **[SETTING]** for chapter selection.
- 14 Enter 0 in response to the prompt for "PARAMETER WRITE (PWE)" of setting data.
- 15 Turn the power to the NC back on.

- 16 Release the EMERGENCY STOP button on the machine operator's panel.

Explanations



- **Pitch error compensation**

Parameters 3620 to 3624 and pitch error compensation data must be set correctly to apply pitch error compensation correctly (See subsec. III-11.5.2)

8.6.4 Outputting Pitch Error Compensation Data

All pitch error compensation data are output in the defined format from the memory of the CNC to a floppy or NC tape.

Procedure for Outputting Pitch Error Compensation Data

- 1 Make sure the output device is ready for output.
For the two-path control, select the tool post for which pitch error compensation data to be output is used with the tool post selection switch.
- 2 Specify the punch code system (ISO or EIA) using a parameter.
- 3 Press the EDIT switch on the machine operator's panel.
- 4 Press function key  .
- 5 Press the rightmost soft key  (next-menu key) and press chapter selection soft key **[PITCH]**.
- 6 Press soft key **[(OPRT)]**.
- 7 Press rightmost soft key  (next-menu key).
- 8 Press soft keys **[PUNCH]** and **[EXEC]**.
All pitch error compensation data are output in the defined format.

Explanations

- **Output format**

Output format is as follows :

N10000 P... ;

N11023 P... ;

N : Pitch error compensation point + 10000

P : Pitch error compensation data

When bi-directional pitch error compensation is used, output format is as follows :

N20000 P... ;

N21023 P... ;

N23000 P... ;

N24023 P... ;

N : Pitch error compensation point + 20000

P : Pitch error compensation data

- **Output file name**

When the floppy disk directory display function is used, the name of the output file is "**PITCH ERROR**".

8.7 INPUTTING / OUTPUTTING CUSTOM MACRO COMMON VARIABLES

8.7.1 Inputting Custom Macro Common Variables

The value of a custom macro common variable (#500 to #999) is loaded into the memory of the CNC from a floppy or NC tape. The same format used to output custom macro common variables is used for input. See Subsec. III-8.7.2. For a custom macro common variable to be valid, the input data must be executed by pressing the cycle start button after data is input. When the value of a common variable is loaded into memory, this value replaces the value of the same common variable already existing (if any) in memory.

Procedure for Inputting Custom Macro Common Variables

- 1 Register the program which has been output, as described in Section III-8.7.2, in memory according to the program input procedure described in Section III-8.4.1.
- 2 Press the MEMORY switch on the machine operator's panel upon completing input.
- 3 Press the cycle start button to execute the loaded program.
- 4 Display the macro variable screen to check whether the values of the common variables have been set correctly.

Display of the macro variable screen

- Press function key  .
- Press the rightmost soft key (next-menu key).
- Press soft key **[MACRO]**.
- Select a variable with the page keys or numeric keys and soft key **[NO.SRH]**.

Explanations



- **Common variables**

The common variables (#500 to #531) can be input and output. When the option for adding a common variable is specified, values from #500 to #999 can be input and output. #100 to #149 can be input and output when bit 3 (PU5) of parameter No. 6001 is set to 1. When the option for adding a common variable is specified, values from #100 to #199 can be input and output.

8.7.2 Outputting Custom Macro Common Variable

Custom macro common variables (#500 to #999) stored in the memory of the CNC can be output in the defined format to a floppy or NC tape.

Procedure for Outputting Custom Macro Common Variable

- 1 Make sure the output device is ready for output.
- 2 Specify the punch code system (ISO or EIA) using a parameter.
- 3 Press the EDIT switch on the machine operator's panel.
- 4 Press function key  .
- 5 Press the rightmost soft key  (next-menu key), then press soft key **[MACRO]**.
- 6 Press soft key **[(OPRT)]**.
- 7 Press the rightmost soft key  (next-menu key).
- 8 Press soft keys **[PUNCH]** and **[EXEC]**.
Common variables are output in the defined format.

Explanations

- **Output format**

The output format is as follows:

```

%
;
;
#500=[25283*65536+65536]/134217728 ..... (1)
#501=#0; ..... (2)
#502=0; ..... (3)
#503= ..... ;
..... ;
..... ;
#531= ..... ;
M02;
%
```

(1) The precision of a variable is maintained by outputting the value of the variable as <expression>.

(2) Undefined variable

(3) When the value of a variable is 0

- **Output file name**

When the floppy disk directory display function is used, the name of the output file is “**MACRO VAR**”.

- **Common variable**

The common variables (#500 to #531) can be input and output.

When the option for adding a common variable is specified, values from #500 to #999 can be input and output.

#100 to #149 can be input and output when bit 3 (PU5) of parameter No. 6001 is set to 1.

When the option for adding a common variable is specified, values from #100 to #199 can be input and output.

8.8 DISPLAYING DIRECTORY OF FLOPPY DISK

On the floppy directory display screen, a directory of the FANUC Handy File, FANUC Floppy Cassette, or FANUC FA Card files can be displayed. In addition, those files can be loaded, output, and deleted.

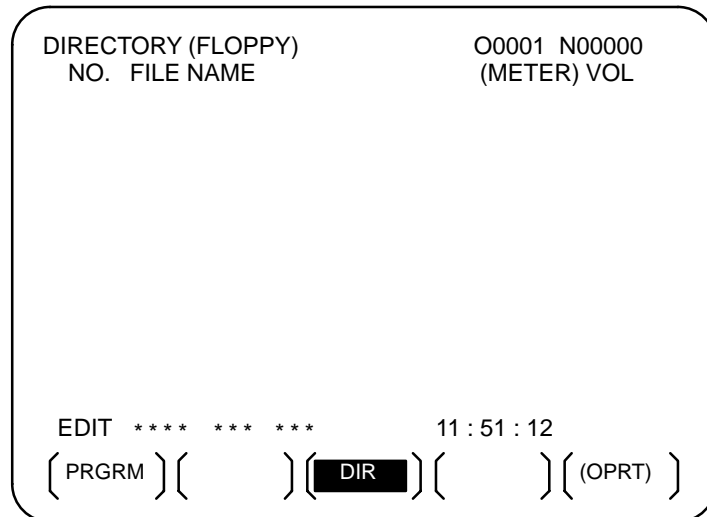





8.8.1 Displaying the Directory

Displaying the Directory of Floppy Disk Files

Procedure 1

Use the following procedure to display a directory of all the files stored in a floppy:

- 1 Press the EDIT switch on the machine operator's panel.
- 2 Press function key  .
- 3 Press the rightmost soft key  (next-menu key).
- 4 Press soft key **[FROPPY]**.
- 5 Press page key  or  .
- 6 The screen below appears.

DIRECTORY (FLOPPY)		O0001 N00000
NO.	FILE NAME	(METER) VOL
0001	PARAMETER	58.5
0002	O0001	1.9
0003	O0002	1.9
0004	O0010	1.3
0005	O0040	1.3
0006	O0050	1.9
0007	O0100	1.9
0008	O1000	1.9
0009	O9500	1.6

EDIT **** * * * * 11 : 53 : 04



{ F SRH } { READ } { PUNCH } { DELETE } { }

Fig. 8.8.1 (a)

- 7 Press a page key again to display another page of the directory.

Procedure 2

Use the following procedure to display a directory of files starting with a specified file number :

- 1 Press the EDIT switch on the machine operator's panel.
- 2 Press function key  .
- 3 Press the rightmost soft key  (next-menu key).
- 4 Press soft key **[FLOPPY]**.
- 5 Press soft key **[(OPRT)]**.
- 6 Press soft key **[F SRH]**.
- 7 Enter a file number.
- 8 Press soft keys **[F SET]** and **[EXEC]**.
- 9 Press a page key to display another page of the directory.
- 10 Press soft key **[CAN]** to return to the soft key display shown in the screen of **Fig. 8.8.1 (b)**.

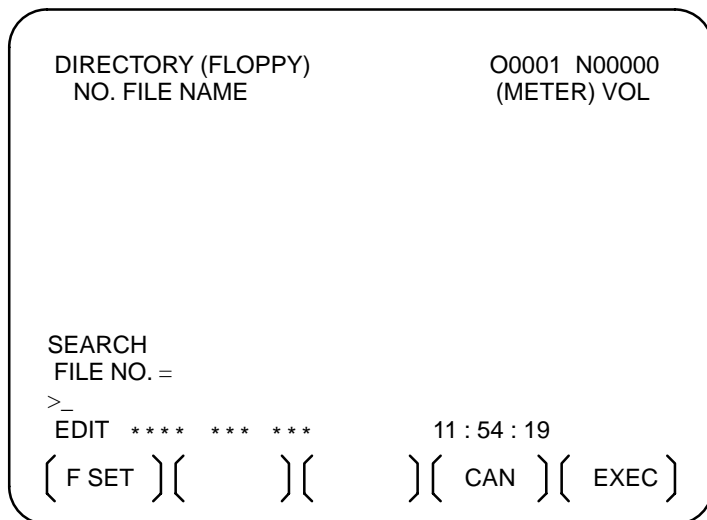

Fig. 8.8.1 (b)

Explanations

- **Screen fields and their meanings**

NO	: Displays the file number
FILE NAME	: Displays the file name.
(METER)	: Converts and prints out the file capacity to paper tape length. You can also produce H (FEET)I by setting the INPUT UNIT to INCH of the setting data.
VOL.	: When the file is multi-volume, that state is displayed.

(Ex.) Floppy or card A

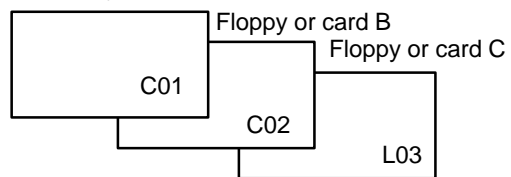



C(number)means CONTINUE
L(number)means LAST
number number of floppies or cards

8.8.2 Reading Files

The contents of the specified file number are read to the memory of NC.

Procedure for Reading Files

- 1 Press the EDIT switch on the machine operator's panel.
For the two-path control, select the tool post for which a file is to be input in memory with the tool post selection switch.
- 2 Press function key  .
- 3 Press the rightmost soft key  (next-menu key).
- 4 Press soft key **[FLOPPY]**.
- 5 Press soft key **[(OPRT)]**.
- 6 Press soft key **[READ]**.



DIRECTORY (FLOPPY)	O0001 N00000
NO. FILE NAME	(METER) VOL
READ	PROGRAM NO. =
FILE NO. =	
>_	
EDIT **** * * * * *	11 : 55 : 04
(F SET) (O SET) (STOP) (CAN) (EXEC)	

- 7 Enter a file number.
- 8 Press soft key **[F SET]**.
- 9 To modify the program number, enter the program number, then press soft key **[O SET]**.
- 10 Press soft key **[EXEC]**. The file number indicated in the lower-left corner of the screen is automatically incremented by one.
- 11 Press soft key **[CAN]** to return to the soft key display shown in the screen of **Fig. 8.8.1. (b)**.

8.8.3 Outputting Programs

Any program in the memory of the CNC unit can be output to a floppy as a file.

Procedure for Outputting Programs

- 1 Press the EDIT switch on the machine operator's panel.
For the two-path control, select the tool post for which a program is to be output from floppy with the tool post selection switch.
- 2 Press function key .
- 3 Press the rightmost soft key  (next-menu key).
- 4 Press soft key **[FLOPPY]**.
- 5 Press soft key **[(OPRT)]**.
- 6 Press soft key **[PUNCH]**



DIRECTORY (FLOPPY) NO. FILE NAME	O0002 N01000 (METER) VOL
PUNCH FILE NO. =	PROGRAM NO. =
>_ EDIT **** * * * *	11 : 55 : 26
{ F SET } { O SET } { STOP } { CAN } { EXEC }	

- 7 Enter a program number. To write all programs into a single file, enter -9999 in the program number field. In this case, the file name "ALL.PROGRAM" is registered.
- 8 Press soft key **[O SET]**.
- 9 Press soft key **[EXEC]**. The program or programs specified in step 7 are written after the last file on the floppy. To output the program after deleting files starting with an existing file number, key in the file number, then press soft key **[F SET]** followed by soft key **[EXEC]**.
- 10 Press soft key **[CAN]** to return to the soft key display shown in the screen of **Fig. 8.8.1 (b)**.

8.8.4 Deleting Files

The file with the specified file number is deleted.

Procedure for Deleting Files

- 1 Press the EDIT switch on the machine operator's panel.
- 2 Press function key .
- 3 Press the rightmost soft key  (next-menu key).
- 4 Press soft key **[FLOPPY]**.
- 5 Press soft key **[(OPRT)]**.
- 6 Press soft key **[DELETE]**.

DIRECTORY (FLOPPY)	O0001 N00000
NO. FILE NAME	(METER) VOL
DELETE	
FILE NO. =	NAME=
>_	
EDIT **** * * * *	11 : 55 : 51
{ F SET } { F NAME } { } { CAN } { EXEC }	

- 7 Specify the file to be deleted.
When specifying the file with a file number, type the number and press soft key **[F SET]**. When specifying the file with a file name, type the name and press soft key **[F NAME]**.
- 8 Press soft key **[EXEC]**.
The file specified in the file number field is deleted. When a file is deleted, the file numbers after the deleted file are each decremented by one.
- 9 Press soft key **[CAN]** to return to the soft key display shown in the screen of **Fig. 8.8.1 (b)**.

Limitations

- **Inputting file numbers and program numbers with keys**
- **I/O devices**
- **Significant digits**
- **Collation**

If **[F SET]** or **[O SET]** is pressed without key inputting file number and program number, file number or program number shows blank. When 0 is entered for file numbers or program numbers, 1 is displayed.

To use channel 0 ,set a device number in parameter 102.
Set the I/O device number to parameter No. 0112 when channel 1 is used.
Set it to No. 0122 when channel 2 is used.

For the numeral input in the data input area with FILE NO. and PROGRAM NO., only lower 4 digits become valid.

When the data protection key on the machine operator's panel is ON, no programs are read from the floppy. They are verified against the contents of the memory of the CNC instead.

ALARM

No.	Contents
71	An invalid file number or program number was entered. (Specified program number is not found.)
79	Verification operation found a mismatch between a program loaded into memory and the contents of the floppy
86	The data set-ready signal (DR) for the input/output device is turned off. (The no file error or duplicate file error occurred on the input/output device because an invalid file number, program number, or file name was entered.)

8.9 OUTPUTTING A PROGRAM LIST FOR A SPECIFIED GROUP

CNC programs stored in memory can be grouped according to their names, thus enabling the output of CNC programs in group units. Section III-11.3.3 explains the display of a program listing for a specified group.

Procedure for Outputting a Program List for a Specified Group

Procedure

- 1 Display the program list screen for a group of programs, as described in Section III-11.3.3.

```

PROGRAM DIRECTORY (GROUP)          O0001 N00010

      PROGRAM (NUM.)      MEMORY (CHAR.)
USED:           60              3321
FREE:           2              429
O0020 (GEAR-1000 MAIN   )
O0040 (GEAR-1000 SUB-1  )
O0200 (GEAR-1000 SUB-2  )
O2000 (GEAR-1000 SUB-3  )

>_
EDIT  ****  ***  ***  ***  16 : 52 : 13
{ PRGRM } { DIR } {      } {      } { (OPRT) }

```

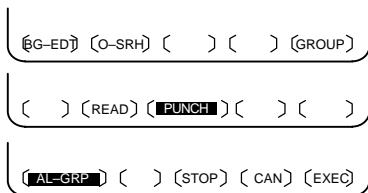

- 2 Press the **[OPRT]** operation soft key.
- 3 Press the right-most soft key  (continuous menu key).
- 4 Press the **[PUNCH]** operation soft key.
- 5 Press the **[AL-GRP]** operation soft key.

The CNC programs in the group for which a search is made are output. When these programs are output to a floppy disk, they are output to a file named GROUP.PROGRAM.

8.10 DATA INPUT/OUTPUT ON THE ALL IO SCREEN

To input/output a particular type of data, the corresponding screen is usually selected. For example, the parameter screen is used for parameter input from or output to an external input/output unit, while the program screen is used for program input or output. However, programs, parameters, offset data, and macro variables can all be input and output using a single common screen, that is, the ALL IO screen.

READ/PUNCH (PROGRAM)		O1234 N12345	
I/O CHANNEL	3	TV CHECK	OFF
DEVICE NUM.	0	PUNCH CODE	ISO
BAUDRATE	4800	INPUT CODE	ASCII
STOP BIT	2	FEED OUTPUT	FEED
NULL INPUT (EIA)	NO	EOB OUTPUT (ISO)	CR
TV CHECK (NOTES)	ON	BAUDRATE CLK. INNER	
CD CHECK (232C)	OFF	RESET/ALARM	ON
PARITY BIT	OFF	SAT COMMAND	HOST
INTERFACE	RS422	COM PROTOCOL	A
END CODE	EXT	COM CODE	ASCII
(0:EIA 1:ISO)>1_			
MDI	**** * * * * *		12:34:56
〔 PRGRM 〕〔 PARAM 〕〔 OFFSET 〕〔 MACRO 〕〔 (OPRT) 〕			



Fig. 8.10 ALL IO screen
(when channel 3 is being used for input/output)

8.10.1 Setting Input/Output-Related Parameters

Input/output-related parameters can be set on the ALL IO screen. Parameters can be set, regardless of the mode.

Setting input/output-related parameters

Procedure

- 1 Press function key .
- 2 Press the rightmost soft key  (next-menu key) several times.
- 3 Press soft key **[ALL IO]** to display the ALL IO screen.

NOTE

- 1 If program or floppy is selected in EDIT mode, the program directory or floppy screen is displayed.
- 2 When the power is first turned on, program is selected by default.

READ/PUNCH (PROGRAM) O1234 N12345

I/O CHANNEL	3	TV CHECK	OFF
DEVICE NUM.	0	PUNCH CODE	ISO
BAUDRATE	4800	INPUT CODE	ASCII
STOP BIT	2	FEED OUTPUT	FEED
NULL INPUT (EIA)	NO	EOB OUTPUT (ISO)	CR
TV CHECK (NOTES)	ON	BAUDRATE CLK. INNER	
CD CHECK (232C)	OFF	RESET/ALARM	ON
PARITY BIT	OFF	SAT COMMAND	HOST
INTERFACE	RS422	COM PROTOCOL	A
END CODE	EXT	COM CODE	ASCII

(0:EIA 1:ISO)>1_

MDI **** * * * * 12:34:56

{ PRGRM } { PARAM } { OFFSET } { MACRO } { (OPRT) }

NOTE

Baud rate clock, CD check (232C), reset/alarm report, and the parity bit for parameter No. 134, as well as the communication code, end code, communication protocol, interface, and SAT command for parameter No. 135 are displayed only when channel 3 is being used for input/output.

- 4 Select the soft key corresponding to the desired type of data (program, parameter, and so forth).
- 5 Set the parameters corresponding to the type of input/output unit to be used. (Parameter setting is possible regardless of the mode.)

8.10.2 Inputting and Outputting Programs

A program can be input and output using the ALL IO screen.
When entering a program using a cassette or card, the user must specify the input file containing the program (file search).

File search

Procedure

- 1 Press soft key **[PRGRM]** on the ALL IO screen, described in Section 8.10.1.
- 2 Select EDIT mode. A program directory is displayed.
- 3 Press soft key **[(OPRT)]**. The screen and soft keys change as shown below.
 - A program directory is displayed only in EDIT mode. In all other modes, the ALL IO screen is displayed.

```

                                O0001 N00010
                                PROGRAM (NUM.)    MEMORY (CHAR.)
                                USED   :    60      3321
                                FREE   :     2      429

                                O0010 O0001 O0003 O0002 O0555 O0999
                                O0062 O0004 O0005 O1111 O0969 O6666
                                O0021 O1234 O0588 O0020 O0040

                                >_
                                EDIT  ****  ***  ***  ***                14:46:09
                                { F SRH } { READ } { PUNCH } { DELETE } { (OPRT) }

```

- 4 Enter address N.
- 5 Enter the number of the file to be found.
 - N0
The first floppy file is found.
 - One of N1 to N9999
Among the files numbered from 1 to 9999, a specified file is found.
 - N-9999
The file immediately after that used most recently is found.
 - N-9998
When -9998 is specified, the next file is found. Then, each time a file input/output operation is performed, N-9999 is automatically inserted. This means that subsequent files can be sequentially found automatically.
This state is canceled by specifying N0, N1 to N9999, or N-9999, or upon a reset.
- 6 Press soft keys **[F SRH]** and **[EXEC]**.
The specified file is found.

{ < } { < } { < } { < } { CAN } { EXEC }

Explanations

- **Difference between N0 and N1**

When a file already exists in a cassette or card, specifying N0 or N1 has the same effect. If N1 is specified when there is no file on the cassette or card, an alarm is issued because the first file cannot be found. Specifying N0 places the head at the start of the cassette or card, regardless of whether the cassette/card already contains files. So, no alarm is issued in this case. N0 can be used, for example, when a program is written into a new cassette or card, or when a previously used cassette or card is used once all the files it contains have been erased.

- **Alarm issue during file search**

If an alarm (file search failure, for example) is generated during file search, the CNC does not issue an alarm immediately. However, a P/S alarm (No. 086) is issued if input/output is subsequently performed on that file.

- **File search using N-9999**

Instead of sequentially searching for files by specifying actual file numbers every time, the user can specify the first file number, then find the subsequent files by specifying N-9999. When N-9999 is specified, the time required for file search can be reduced.

Inputting a program

Procedure

- 1 Press soft key **[PRGRM]** on the ALL IO screen, described in Section 8.10.1.
- 2 Select EDIT mode. A program directory is displayed.
- 3 Press soft key **[(OPRT)]**. The screen and soft keys change as shown below.
 - A program directory is displayed only in EDIT mode. In all other modes, the ALL IO screen is displayed.

```

O0001 N00010
          PROGRAM (NUM.)    MEMORY (CHAR.)
USED   :    60             3321
FREE   :     2             429

O0010 O0001 O0003 O0002 O0555 O0999
O0062 O0004 O0005 O1111 O0969 O6666
O0021 O1234 O0588 O0020 O0040

>_
EDIT  ****  ***  ***  ***                14:46:09
〔 F SRH 〕〔 READ 〕〔 PUNCH 〕〔 DELETE 〕〔 (OPRT) 〕

```

- 4 To specify a program number to be assigned to an input program, enter address O, followed by the desired program number. If no program number is specified, the program number in the file or on the NC tape is assigned as is.

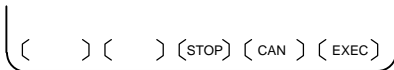

- 5 Press soft key **[READ]**, then **[EXEC]**.
 The program is input with the program number specified in step 4 assigned.
 To cancel input, press soft key **[CAN]**.
 To stop input prior to its completion, press soft key **[STOP]**.

Outputting a program

Procedure

- 1 Press soft key **[PRGRM]** on the ALL IO screen, described in Section 8.10.1.
- 2 Select EDIT mode. A program directory is displayed.
- 3 Press soft key **[(OPRT)]**. The screen and soft keys change as shown below.
 - A program directory is displayed only in EDIT mode. In all other modes, the ALL IO screen is displayed.

```

                                O0001 N00010
                                PROGRAM (NUM.)   MEMORY (CHAR.)
                                USED   :    60     3321
                                FREE   :    2      429

                                O0010 O0001 O0003 O0002 O0555 O0999
                                O0062 O0004 O0005 O1111 O0969 O6666
                                O0021 O1234 O0588 O0020 O0040

                                >_
                                EDIT  ****  ***  ***  ***          14:46:09
                                ( F SRH ) ( READ ) ( PUNCH ) ( DELETE ) ( (OPRT) )
  
```

- 4 Enter address O.
- 5 Enter a desired program number.
 If -9999 is entered, all programs in memory are output.
 To output a range of programs, enter O△△△△, O□□□□. The programs numbered from △△△△ to □□□□ are output.
 When bit 4 (SOR) of parameter No. 3107 for sorted display is set to 1 on the program library screen, programs are output in order, starting from those having the smallest program numbers.

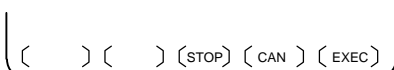

- 6 Press soft key **[PUNCH]**, then **[EXEC]**.
 The specified program or programs are output. If steps 4 and 5 are omitted, the currently selected program is output.
 To cancel output, press soft key **[CAN]**.
 To stop output prior to its completion, press soft key **[STOP]**.

Deleting files

Procedure

- 1 Press soft key **[PRGRM]** on the ALL IO screen, described in Section 8.10.1.
- 2 Select EDIT mode. A program directory is displayed.
- 3 Press soft key **[(OPRT)]**. The screen and soft keys change as shown below.
 - A program directory is displayed only in EDIT mode. In all other modes, the ALL IO screen is displayed.

```

                                O0001 N00010
                                PROGRAM (NUM.)   MEMORY (CHAR.)
                                USED  :    60      3321
                                FREE  :     2      429

                                O0010 O0001 O0003 O0002 O0555 O0999
                                O0062 O0004 O0005 O1111 O0969 O6666
                                O0021 O1234 O0588 O0020 O0040

                                >_
                                EDIT  ****  ***  ***  ***          14:46:09
                                [ F SRH ] [ READ ] [ PUNCH ] [ DELETE ] [ (OPRT) ]

```

- 4 Press soft key **[DELETE]**.
- 5 Enter a file number, from 1 to 9999, to indicate the file to be deleted.
- 6 Press soft key **[EXEC]**.
The k-th file, specified in step 5, is deleted.

[<] [>] [CAN] [EXEC]

Explanations

- **File numbers after deletion**

After deletion of the k-th file, the previous file numbers (k+1) to n are decremented by 1 to k to (n-1).

Before deletion	After deletion
1 to (k-1)	1 to (k-1)
k	Deleted
(k+1) to n	k to (n-1)

- **Write protect**

Before a file can be deleted, the write protect switch of the cassette must be set to make the cassette writable.

8.10.3

Parameters can be input and output using the ALL IO screen.

Inputting and Outputting Parameters**Inputting parameters****Procedure**

- 1 Press soft key **[PARAM]** on the ALL IO screen, described in Section 8.10.1.
- 2 Select EDIT mode.
- 3 Press soft key **[OPRT]**. The screen and soft keys change as shown below.

```

READ/PUNCH (PARAMETER)                O1234 N12345

I/O CHANNEL          3      TV CHECK      OFF
DEVICE NUM.          0      PUNCH CODE    ISO
BAUDRATE             4800    INPUT CODE    ASCII
STOP BIT             2      FEED OUTPUT   FEED
NULL INPUT (EIA)     NO     EOB OUTPUT (ISO) CR
TV CHECK (NOTES)     ON     BAUDRATE CLK. INNER
CD CHECK (232C)      OFF    RESET/ALARM      ON
PARITY BIT           OFF    COM CODE         ASCII
END CODE             EXT    COM PROTOCOL     A
INTERFACE            RS422   SAT COMMAND      HOST

(O:EIA 1:ISO)>1_
MDI  ****  ***  ***  ***
      {      } { READ } { PUNCH } {      } {      }

```

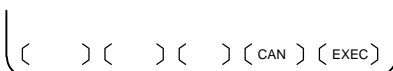

- 4 Press soft key **[READ]**, then **[EXEC]**.
The parameters are read, and the “INPUT” indicator blinks at the lower-right corner of the screen. Upon the completion of input, the “INPUT” indicator is cleared from the screen.
To cancel input, press soft key **[CAN]**.

Outputting parameters

Procedure

- 1 Press soft key **[PARAM]** on the ALL IO screen, described in Section 8.10.1.
- 2 Select EDIT mode.
- 3 Press soft key **[(OPRT)]**. The screen and soft keys change as shown below.

```

READ/PUNCH (PARAMETER)                O1234 N12345
I/O CHANNEL                3          TV CHECK                OFF
DEVICE NUM.                 0          PUNCH CODE              ISO
BAUDRATE                    4800       INPUT CODE              ASCII
STOP BIT                    2          FEED OUTPUT            FEED
NULL INPUT (EIA)           NO          EOB OUTPUT (ISO)      CR
TV CHECK (NOTES)          ON          BAUDRATE CLK.        INNER
CD CHECK (232C)           OFF         RESET/ALARM          ON
PARITY BIT                 OFF         COM CODE              ASCII
END CODE                   EXT         COM PROTOCOL         A
INTERFACE                   RS422      SAT COMMAND          HOST
(0:EIA 1:ISO)>1_
MDI  ****  ***  ***  ***  12:34:56
(      ) ( READ ) ( PUNCH ) (      ) (      )
    
```

```

(      ) (      ) (      ) ( CAN ) ( EXEC )
    
```

- 4 Press soft key **[PUNCH]**, then **[EXEC]**.
 The parameters are output, and the “OUTPUT” indicator blinks at the lower-right corner of the screen. Upon the completion of output, the “OUTPUT” indicator is cleared from the screen.
 To cancel output, press soft key **[CAN]**.

8.10.4

Offset data can be input and output using the ALL IO screen.

Inputting and Outputting Offset Data**Inputting offset data****Procedure**

- 1 Press soft key **[OFFSET]** on the ALL IO screen, described in Section 8.10.1.
- 2 Select EDIT mode.
- 3 Press soft key **[OPRT]**. The screen and soft keys change as shown below.

```

READ/PUNCH (OFFSET)                                O1234 N12345
I/O CHANNEL          3          TV CHECK          OFF
DEVICE NUM.          0          PUNCH CODE        ISO
BAUDRATE             4800       INPUT CODE        ASCII
STOP BIT             2          FEED OUTPUT       FEED
NULL INPUT (EIA)     NO         EOB OUTPUT (ISO) CR
TV CHECK (NOTES)     ON         BAUDRATE CLK. INNER
CD CHECK (232C)      OFF        RESET/ALARM    ON
PARITY BIT           OFF        COM CODE        ASCII
END CODE             EXT        COM PROTOCOL    A
INTERFACE            RS422      SAT COMMAND    HOST
(O:EIA 1:ISO)>1_
MDI  ****  ***  ***  ***
(      ) ( READ ) ( PUNCH ) (      ) (      )

```

```

(      ) (      ) (      ) ( CAN ) ( EXEC )

```

- 4 Press soft key **[READ]**, then **[EXEC]**.
The offset data is read, and the “INPUT” indicator blinks at the lower-right corner of the screen.
Upon the completion of input, the “INPUT” indicator is cleared from the screen.
To cancel input, press soft key **[CAN]**.

Outputting offset data

Procedure

- 1 Press soft key **[OFFSET]** on the ALL IO screen, described in Section 8.10.1.
- 2 Select EDIT mode.
- 3 Press soft key **[(OPRT)]**. The screen and soft keys change as shown below.

```

READ/PUNCH (OFFSET)                                O1234 N12345
I/O CHANNEL          3      TV CHECK             OFF
DEVICE NUM.          0      PUNCH CODE           ISO
BAUDRATE             4800   INPUT CODE           ASCII
STOP BIT             2      FEED OUTPUT          FEED
NULL INPUT (EIA)     NO     EOB OUTPUT (ISO)     CR
TV CHECK (NOTES)     ON     BAUDRATE CLK. INNER
CD CHECK (232C)      OFF    RESET/ALARM      ON
PARITY BIT           OFF    COM CODE            ASCII
END CODE             EXT    COM PROTCOL         A
INTERFACE            RS422   SAT COMMAND       HOST
(0:EIA 1:ISO)>1_
MDI  ****  ***  ***  ***  12:34:56
(      ) ( READ ) ( PUNCH ) (      ) (      )
    
```

```

(      ) (      ) (      ) ( CAN ) ( EXEC )
    
```

- 4 Press soft key **[PUNCH]**, then **[EXEC]**. The offset data is output, and the “OUTPUT” indicator blinks at the lower-right corner of the screen. Upon the completion of output, the “OUTPUT” indicator is cleared from the screen. To cancel output, press soft key **[CAN]**.

8.10.5

Outputting Custom Macro Common Variables

Custom macro common variables can be output using the ALL IO screen.

Outputting custom macro common variables

Procedure

- 1 Press soft key **[MACRO]** on the ALL IO screen, described in Section 8.10.1.
- 2 Select EDIT mode.
- 3 Press soft key **[OPRT]**. The screen and soft keys change as shown below.

```

READ/PUNCH (MACRO)                                O1234 N12345
I/O CHANNEL          3      TV CHECK             OFF
DEVICE NUM.          0      PUNCH CODE           ISO
BAUDRATE             4800   INPUT CODE           ASCII
STOP BIT             2      FEED OUTPUT         FEED
NULL INPUT (EIA)     NO     EOB OUTPUT (ISO)     CR
TV CHECK (NOTES)     ON     BAUDRATE CLK. INNER
CD CHECK (232C)      OFF    RESET/ALARM      ON
PARITY BIT           OFF    COM CODE           ASCII
END CODE             EXT    COM PROTOCOL      A
INTERFACE            RS422   SAT COMMAND      HOST
(0:EIA 1:ISO)>1_
MDI  ****  ***  ***  ***  12:34:56
{      } { READ } { PUNCH } {      } {      }

```

```
{ <  > <  > <  > { CAN } { EXEC }
```

- 4 Press soft key **[PUNCH]**, then **[EXEC]**. The custom macro common variables are output, and the “OUTPUT” indicator blinks at the lower-right corner of the screen. Upon the completion of output, the “OUTPUT” indicator is cleared from the screen. To cancel output, press soft key **[CAN]**.

NOTE

To input a macro variable, read the desired custom macro statement as a program, then execute the program.

8.10.6 Inputting and Outputting Floppy Files

The ALL IO screen supports the display of a directory of floppy files, as well as the input and output of floppy files.

Displaying a file directory

Procedure

- 1 Press the rightmost soft key  (next-menu key) on the ALL IO screen, described in Section 8.10.1.
- 2 Press soft key **[FLOPPY]**.
- 3 Select EDIT mode. The floppy screen is displayed.
- 4 Press soft key **[(OPRT)]**. The screen and soft keys change as shown below.
The floppy screen is displayed only in EDIT mode. In all other modes, the ALL IO screen is displayed.

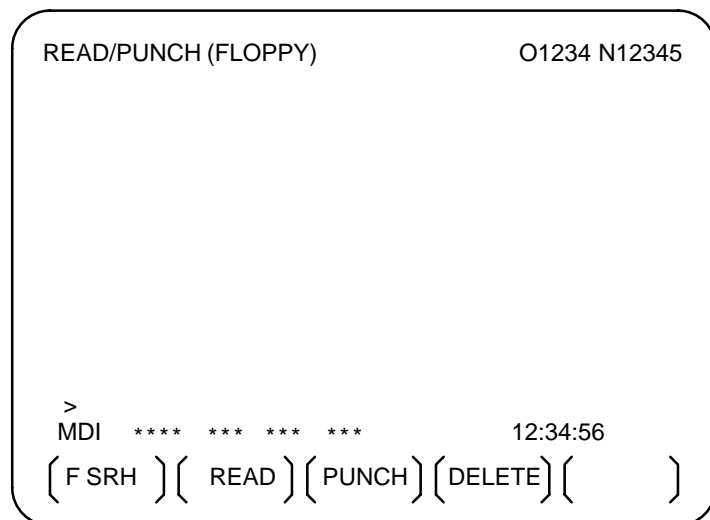

- 5 Press soft key **[F SRH]**.
- 6 Enter the number of the desired file, then press soft key **[F SET]**.

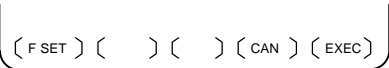

- 7 Press soft key **[EXEC]**. A directory is displayed, with the specified file uppermost. Subsequent files in the directory can be displayed by pressing the page key.

READ/PUNCH (FLOPPY)		O1234 N12345
No.	FILE NAME	(Meter) VOL
0001	PARAMETER	46.1
0002	ALL.PROGRAM	12.3
0003	O0001	1.9
0004	O0002	1.9
0005	O0003	1.9
0006	O0004	1.9
0007	O0005	1.9
0008	O0010	1.9
0009	O0020	1.9
F SRH		
File No.=2		
>2_		
EDIT	**** * * * * *	12:34:56
{ F SRH }	{ }	{ CAN }
{ }	{ }	{ EXEC }

A directory in which the first file is uppermost can be displayed simply by pressing the page key. (Soft key **[F SRH]** need not be pressed.)

Inputting a file

Procedure

- 1 Press the rightmost soft key  (next-menu key) on the ALL IO screen, described in Section 8.10.1.
- 2 Press soft key **[FLOPPY]**.
- 3 Select EDIT mode. The floppy screen is displayed.
- 4 Press soft key **[OPRT]**. The screen and soft keys change as shown below.
The floppy screen is displayed only in EDIT mode. In all other modes, the ALL IO screen is displayed.

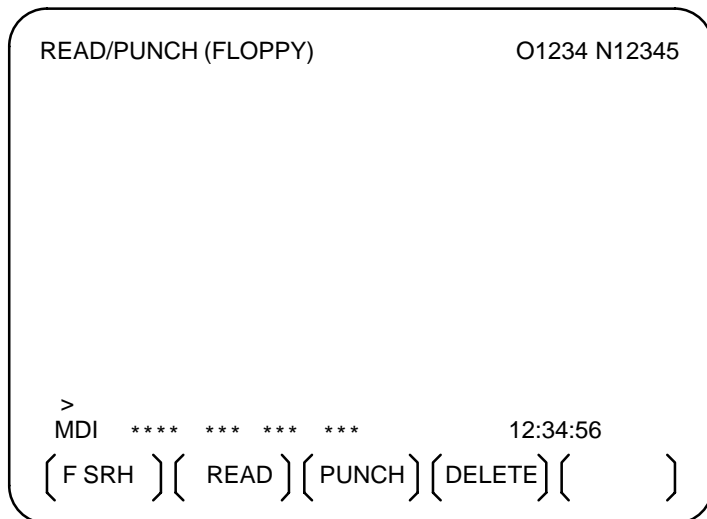

- 5 Press soft key **[READ]**.
- 6 Enter the number of a file or program to be input.
 - Setting a file number: Enter the number of the desired file, then press soft key **[F SET]**.
 - Setting a program number: Enter the number of the desired program, then press soft key **[O SET]**.
- 7 Press soft key **[EXEC]**.
The specified file or program is read, and the “INPUT” indicator blinks at the lower-right corner of the screen. Upon the completion of input, the “INPUT” indicator is cleared from the screen.

[F SET] [O SET] [STOP] [CAN] [EXEC]

Outputting a file

Procedure

- 1 Press the rightmost soft key  (next–menu key) on the ALL IO screen, described in Section 8.10.1.
- 2 Press soft key **[FLOPPY]**.
- 3 Select EDIT mode. The floppy screen is displayed.
- 4 Press soft key **[(OPRT)]**. The screen and soft keys change as shown below.
The floppy screen is displayed only in EDIT mode. In all other modes, the ALL IO screen is displayed.

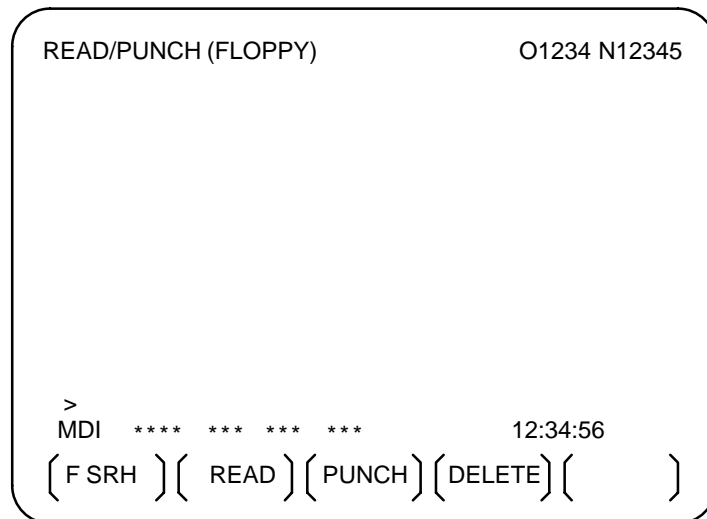

- 5 Press soft key **[PUNCH]**.
- 6 Enter the number of the program to be output, together with a desired output file number.
 - Setting a file number: Enter the number of the desired file, then press soft key **[F SET]**.
 - Setting a program number: Enter the number of the desired program, then press soft key **[O SET]**.
- 7 Press soft key **[EXEC]**.
The specified program is output, and the “OUTPUT” indicator blinks at the lower–right corner of the screen. Upon the completion of output, the “OUTPUT” indicator is cleared from the screen.
If no file number is specified, the program is written at the end of the currently registered files.

[F SET] [O SET] [STOP] [CAN] [EXEC]

Deleting a file

Procedure

- 1 Press the rightmost soft key  (next-menu key) on the ALL IO screen, described in Section 8.10.1.
- 2 Press soft key **[FLOPPY]**.
- 3 Select EDIT mode. The floppy screen is displayed.
- 4 Press soft key **[(OPRT)]**. The screen and soft keys change as shown below.
The floppy screen is displayed only in EDIT mode. In all other modes, the ALL IO screen is displayed.

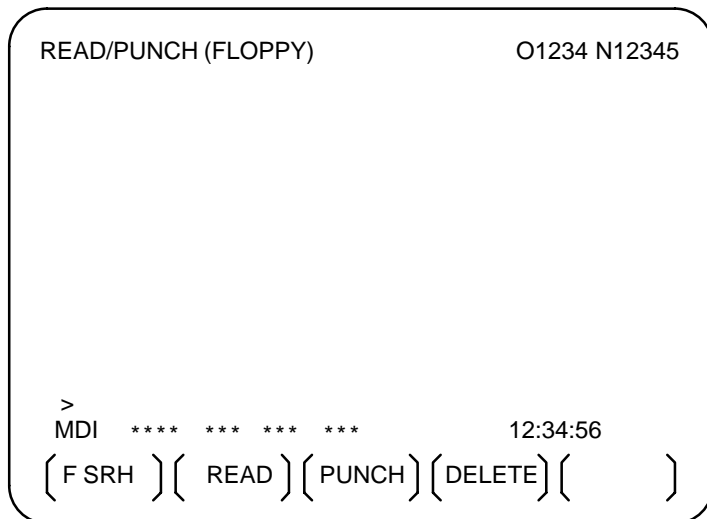

- 5 Press soft key **[DELETE]**.
- 6 Enter the number of the desired file, then press soft key **[F SET]**.
- 7 Press soft key **[EXEC]**. The specified file is deleted. After the file has been deleted, the subsequent files are shifted up.

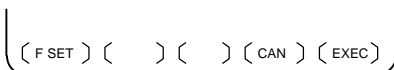

8.10.7 Memory Card Input/Output

Data held in CNC memory can be saved to a memory card in MS-DOS format. Data held on a memory card can be loaded into CNC memory. A save or load operation can be performed using soft keys while the CNC is operating.

Loading can be performed in either of two ways. In the first method, all saved memory data is loaded. In the second method, only selected data is loaded.

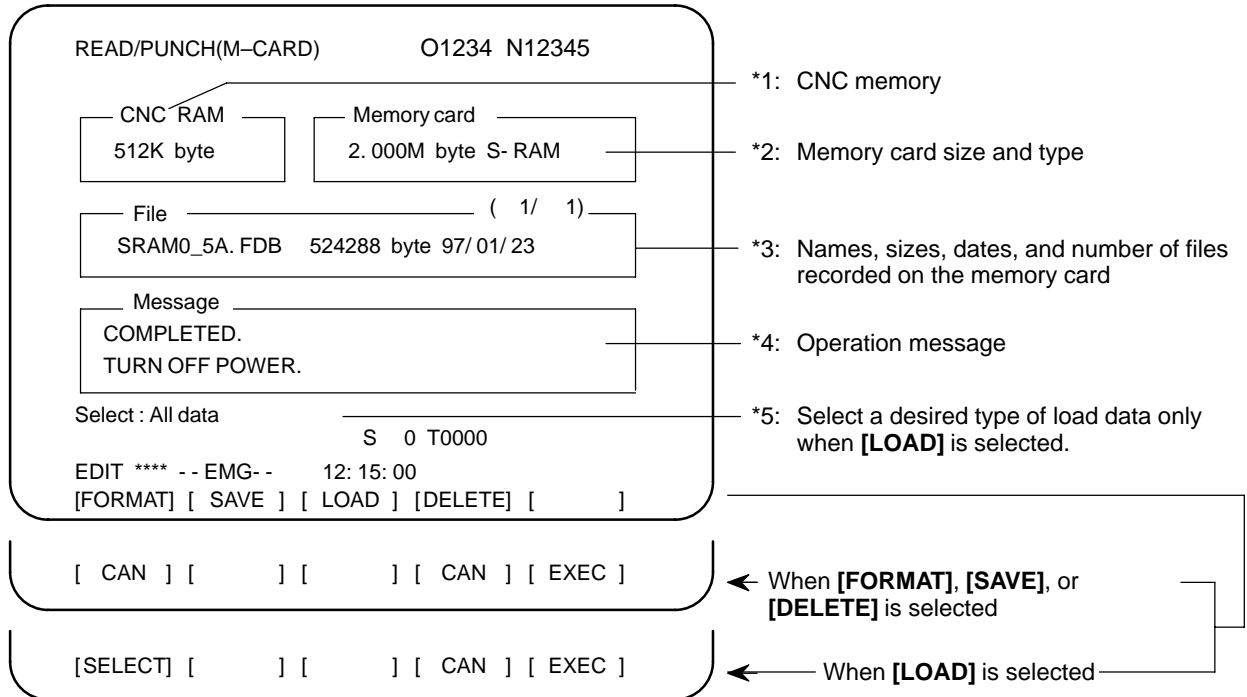

- The CNC memory size (*1) is displayed at all times.
- When no memory card is inserted, the message field (*4) displays a message prompting the user to insert a memory card, but does not display the memory card states (*2 and *3).
- If an inserted memory card is invalid (if there is no attribute memory, or if the attribute memory does not contain any device information), the message field (*4) displays an error message, but does not display the memory card states (*2 and *3).

Saving memory data

Data held in CNC memory can be saved to a memory card in MS-DOS format.

Saving memory data

Procedure

- 1 Press the rightmost soft key  (next-menu key) on the ALL IO screen, described in Section 8.10.1.
- 2 Press soft key **[M-CARD]**.
- 3 Place the CNC in the emergency stop state.
- 4 When a memory card is inserted, the state of the memory card is displayed as shown below.

READ/PUNCH(M-CARD)		O1234 N12345	
CNC RAM 512K byte	Memory card 2.000M byte S- RAM		
File _____ (1/ 1)			
SRAM0_5A. FDB 524288 byte 97/ 01/ 23			
Message _____			
Select : All data		S 0 T0000	
EDIT **** -- EMG- - 12: 15: 00			
[FORMAT] [SAVE] [LOAD] [DELETE] []			

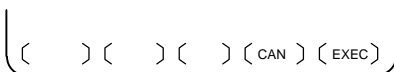

- 5 Press soft key **[SAVE]**.
- 6 A message prompting the user to confirm the operation is displayed. Press soft key **[EXEC]** to execute the save operation.
- 7 As the data is being saved to the card, the message “RUNNING” blinks, and the number of bytes saved is displayed in the message field.
- 8 Once all data has been saved to the card, the message “COMPLETED” is displayed in the message field, with the message “PRESS RESET KEY.” displayed on the second line.
- 9 Press the RESET key. The displayed messages are cleared from the screen, and the display of the memory card state is replaced with that of the saved file.

NOTE

All CNC memory data is saved to a memory card. CNC memory data cannot be saved selectively.

Explanations

- File name**

The file name used for save operation is determined by the amount of SRAM mounted in the CNC. A file holding saved data is divided into blocks of 512KB.

HEAD1 SRAM file

Amount of SRAM		256 KB	0.5 MB	1.0 MB	2.5 MB
Number of files	1	SRAM256A. FDB	SRAM0_5A. FDB	SRAM1_0A. FDB SRAM1_0B. FDB	SRAM2_5A. FDB
	2				SRAM2_5B. FDB
	3				SRAM2_5C. FDB
	4				SRAM2_5D. FDB
	5				SRAM2_5E. FDB

HEAD2 SRAM file

Amount of SRAM		256 KB	0.5 MB	1.0 MB	2.5 MB
Number of files	1	SRAM256A. OP2	SRAM0_5A. OP2	SRAM1_0A. OP2 SRAM1_0B. OP2	SRAM2_5A. OP2
	2				SRAM2_5B. OP2
	3				SRAM2_5C. OP2
	4				SRAM2_5D. OP2
	5				SRAM2_5E. OP2

- Canceling saving**

To cancel file save prior to its completion, press the  key on the MDI panel.
- Memory card replacement request**

When the memory card has less than 512K bytes of free space, a memory card replacement request is displayed. Insert a new memory card.

Loading data into memory (restoration)

CNC memory data that has been saved to a memory card can be loaded (restored) back into CNC memory.

CNC memory data can be loaded in either of two ways. In the first method, all saved memory data is loaded. In the second method, only selected data is loaded.

Loading memory data

Procedure

- 1 Press the rightmost soft key  (next-menu key) on the ALL IO screen, described in Section 8.10.1.
- 2 Press soft key **[M-CARD]**.
- 3 Place the CNC in the emergency stop state.
- 4 When a memory card is inserted, the state of the memory card is displayed as shown below.

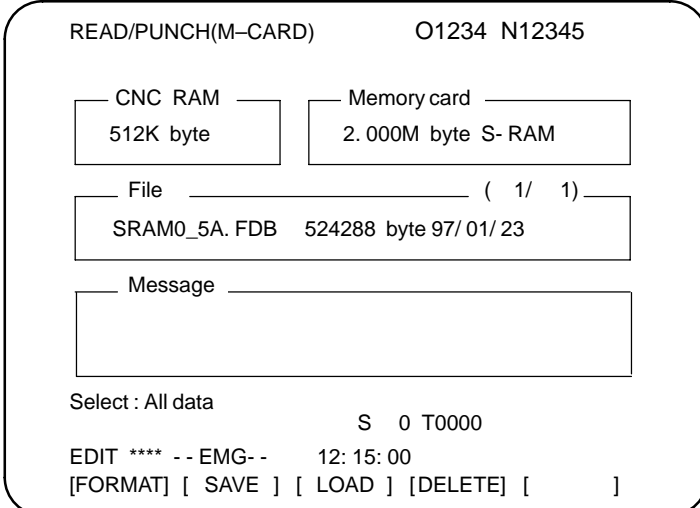

READ/PUNCH(M-CARD) O1234 N12345



CNC RAM 512K byte	Memory card 2.000M byte S-RAM
----------------------	----------------------------------

File (1 / 1)
SRAM0_5A.FDB 524288 byte 97/01/23

Message

Select : All data S 0 T0000

EDIT **** -- EMG-- 12:15:00
[FORMAT] [SAVE] [LOAD] [DELETE] []

- 5 Press soft key **[LOAD]**.
- 6 With cursor keys  and , select the file to be loaded from the memory card.
A system having 1.0MB or 2.5MB of CNC RAM may require the loading of multiple files. All or selective data load can be specified for each file.
- 7 To perform selective data loading, press soft key **[SELECT]**, then select the data to be loaded. Each time the soft key is pressed, the information displayed changes cyclically, as shown below.

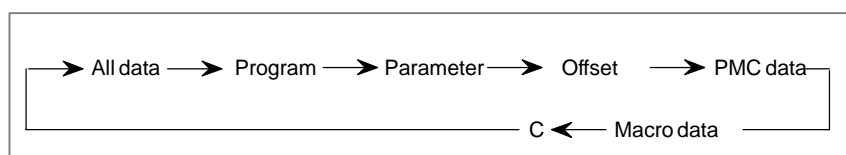
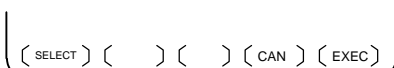

- 8 After checking the file selection, press soft key **[EXEC]**.

- 9 During loading, the message “RUNNING” blinks, and the number of bytes loaded is displayed in the message field.
- 10 Upon the completion of loading, the message “COMPLETED” is displayed in the message field, with the message “PRESS RESET KEY.” displayed on the second line.
- 11 Press the RESET key. The messages are cleared from the screen.

Explanations

- **Canceling loading**

To cancel file load prior to its completion, press the  key on the MDI panel.

- **Turning off the power after loading**

Depending on the type of data, the system power may have to be turned off, then back on, for the load to become effective. When necessary, the message “TURN OFF POWER.” is displayed in the message field.

- **Parameter/PMC data**

Before performing parameter/PMC data load, enable parameter write.

- **Program/offset data**

Before performing program/offset data load, set the data protection key, on the machine operator’s panel, to the ON position.

- **Loading files from multiple memory cards**

When multiple files are to be loaded from multiple memory cards, a message requesting memory card replacement is displayed.

NOTE

If the saved data and CNC system onto which the saved data is to be loaded do not satisfy the conditions described below, an error message is displayed in the message field, and loading is disabled. Note, however, that in selective loading, even if the CNC system structure differs from that of a saved file, the file is never the less loaded.

- The size of a saved file does not match the size of CNC RAM.
- The saved file has a different extension.

Memory card formatting

Before a file can be saved to a memory card, the memory card must be formatted.

Formatting a memory card

Procedure

- 1 Press the rightmost soft key  (next-menu key) on the ALL IO screen, described in Section 8.10.1.
- 2 Press soft key **[M-CARD]**.
- 3 Place the CNC in the emergency stop state.
- 4 When a memory card is inserted, the state of the memory card is displayed as shown below.

READ/PUNCH(M-CARD) O1234 N12345

CNC RAM 512K byte	Memory card 2.000M byte S- RAM
File _____ (1 / 1) SRAM0_5A.FDB 524288 byte 97/01/23	
Message _____ _____	
Select : All data S 0 T0000	
EDIT **** -- EMG-- 12:15:00	
[FORMAT] [SAVE] [LOAD] [DELETE] []	

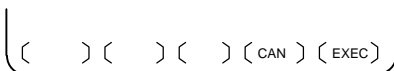

- 5 Press soft key **[FORMAT]**.
- 6 A message prompting the user to confirm the operation is displayed. Press soft key **[EXEC]** to execute the formatting operation.
- 7 As formatting is being performed, the message “FORMATTING” blinks.
- 8 Upon the completion of formatting, the message “COMPLETED” is displayed in the message field.

Deleting files

Unnecessary saved files can be deleted from a memory card.



Deleting files

Procedure

- 1 Press the rightmost soft key  (next-menu key) on the ALL IO screen, described in Section 8.10.1.
- 2 Press soft key **[M-CARD]**.
- 3 Place the CNC in the emergency stop state.
- 4 When a memory card is inserted, the state of the memory card is displayed as shown below.

READ/PUNCH(M-CARD) O1234 N12345

CNC RAM 512K byte	Memory card 2.000M byte S- RAM
File _____ (1/ 1) SRAM0_5A. FDB 524288 byte 97/ 01/ 23	
Message _____ 	
Select : All data S 0 T0000	
EDIT **** -- EMG-- 12: 15: 00	
[FORMAT] [SAVE] [LOAD] [DELETE] []	

- 5 Press soft key **[DELETE]**.
- 6 With cursor keys  and , select the file to be deleted from the memory card.
- 7 After checking the file selection, press soft key **[EXEC]**.
- 8 As detection is being performed, the message “DELETING” blinks in the message field.
- 9 Upon the completion of deletion, the message “COMPLETED” is displayed in the message field.

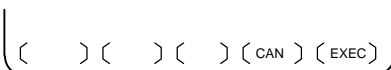

NOTE

An SRAM of 1M bytes or more will contain multiple files. To delete the contents of such an SRAM, delete all the contained files.

Message and restrictions

Messages

Message	Description
INSERT MEMORY CARD.	No memory card is inserted.
UNUSABLE MEMORY CARD	The memory card does not contain device information.
FORMAT MEMORY CARD.	The memory card is not formatted. Format the memory card before use.
THE FILE IS UNUSABLE.	The format or extension of the file to be loaded is invalid. Alternatively, the data stored on the memory card does not match the CNC memory size.
REPLACE MEMORY CARD.	Replace the memory card.
FILE SYSTEM ERROR □□□	An error occurred during file system processing. □□□ represents a file system error code.
SET EMERGENCY STOP STATE.	Save/load operation is enabled in the emergency stop state only.
WRITE-PROTECTED	Save operation: The protect switch of the memory card is set to the disabled position. Load operation: Parameter write is disabled.
VOLTAGE DECREASED.	The battery voltage of the memory card has dropped. (The battery requires replacement.)
DEVICE IS BUSY.	Another user is using the memory card. Alternatively, the device cannot be accessed because automatic operation is in progress.
SRAM → MEMORY CARD?	This message prompts the user to confirm the start of data saving.
MEMORY CARD → SRAM?	This message prompts the user to confirm the start of data loading.
DO YOU WANT TO DELETE FILE(S)?	This message prompts the user to confirm the start of deletion.
DO YOU WANT TO PERFORM FORMATTING?	This message prompts the user to confirm the start of formatting.
SAVING	Saving is currently being performed.
LOADING	Loading is currently being performed.
DELETING	File deletion is currently being performed.
FORMATTING	Memory card formatting is currently being performed.
COMPLETED	Save or load processing has been completed.
PRESS RESET KEY.	Press the RESET key.
TURN OFF POWER.	Turn the power off, then back on again.

File system error codes

Code	Meaning
102	The memory card does not have sufficient free space.
105	No memory card is mounted.
106	A memory card is already mounted.
110	The specified directory cannot be found.
111	There are too many files under the root directory to allow a directory to be added.
114	The specified file cannot be found.
115	The specified file is protected.
117	The file has not yet been opened.
118	The file is already open.
119	The file is locked.
122	The specified file name is invalid.
124	The extension of the specified file is invalid.
129	A non-corresponding function was specified.
130	The specification of a device is invalid.
131	The specification of a pathname is invalid.
133	Multiple files are open at the same time.
135	The device is not formatted.
140	The file has the read/write disabled attribute.

Restrictions

- **Memory card size**

The size of the memory card to be used must be larger than that of the RAM module mounted in the CNC. The size of the RAM module can be determined from the system configuration screen.
- **Memory card specifications**

Use a memory card that conforms to PCMCIA Ver. 2.0, or JEIDA Ver. 4.1.
- **Attribute memory**

A memory card which has no attribute memory, or no device information in its attribute memory, cannot be used.
- **Compatibility of saved data**

Data saved to a memory card is compatible only with CNCs that have the same hardware configuration and the same option configuration.
- **Flash ROM card**

A flash ROM card can be used only for data loading.
- **Operation during automatic operation**

During automatic operation, the contents of a memory card cannot be displayed, formatted, or deleted. To enable these operations, therefore, stop or suspend automatic operation.

8.11 DATA INPUT/OUTPUT USING A MEMORY CARD

By setting the I/O channel (parameter No. 20) to 4, files on a memory card can be referenced, and different types of data such as part programs, parameters, and offset data on a memory card can be input and output in text file format.



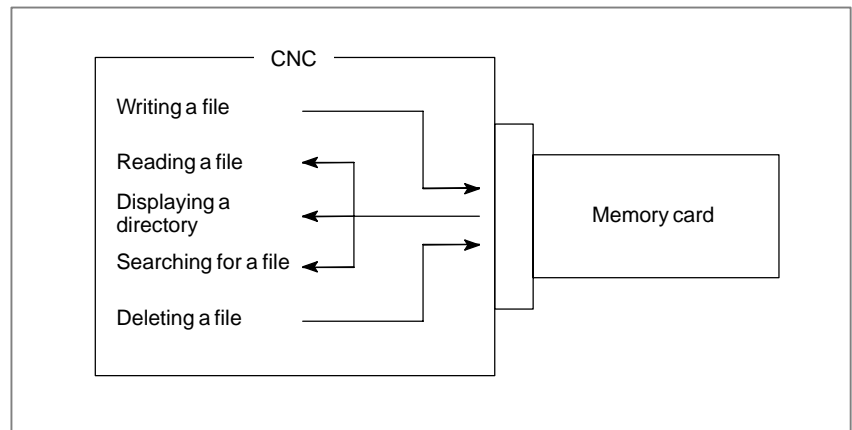

The major functions are listed below.

- **Displaying a directory of stored files**
The files stored on a memory card can be displayed on the directory screen.
- **Searching for a file**
A search is made for a file on a memory card and, if found, it is displayed on the directory screen.
- **Reading a file**
Text-format files can be read from a memory card.
- **Writing a file**
Data such as part programs can be stored to a memory card in text file format.
- **Deleting a file**
A file can be selected and deleted from a memory card.



Displaying a directory of stored files

Procedure

- 1 Press the EDIT switch on the machine operator's panel.
- 2 Press function key  .
- 3 Press the rightmost soft key  (next-menu key).
- 4 Press soft key **[CARD]**. The screen shown below is displayed. Using page keys  and , the screen can be scrolled.

DIRECTORY (M-CARD)			O0034 N00045
No.	FILE NAME	SIZE	DATE
0001	O1000	123456	96/07/10
0002	O1001	8458	96/07/30
0003	O0002	3250	96/07/30
0004	O2000	73456	96/07/31
0005	O2001	3444	96/07/31
0006	O3001	8483	96/08/02
0007	O3300	406	96/08/05
0008	O3400	2420	96/07/31
0009	O3500	7460	96/07/31

~ ([PROG] ([] ([DIR +] ([] ([OPRT]))))) ~

- 5 Comments relating to each file can be displayed by pressing soft key **[DIR+]**.



DIRECTORY (M-CARD)			O0034 N00045
No.	FILE NAME		COMMENT
0001	O1000		(COMMENT)
0002	O1001		(SUB PROGRAM)
0003	O0002		(12345678)
0004	O2000		()
0005	O2001		()
0006	O3001		(SKIP-K)
0007	O3300		(HI-SPEED)
0008	O3400		()
0009	O3500		(TEST PROGRAM)

~ ([PROG] ([] ([DIR +] ([] ([OPRT]))))) ~

- 6 Repeatedly pressing soft key **[DIR+]** toggles the screen between the display of comments and the display of sizes and dates. Any comment described after the O number in the file is displayed. Up to 18 characters can be displayed on the screen.

Searching for a file

Procedure

- 1 Press the EDIT switch on the machine operator's panel.
- 2 Press function key  .
- 3 Press the rightmost soft key  (next-menu key).
- 4 Press soft key **[CARD]**. The screen shown below is displayed.

DIRECTORY (M-CARD)			O0034 N00045
No.	FILE NAME	SIZE	DATE
0001	O1000	123456	96/07/10
0002	O1001	8458	96/07/30
0003	O0002	3250	96/07/30
0004	O2000	73456	96/07/31
0005	O2001	3444	96/07/31
0006	O3001	8483	96/08/02
0007	O3300	406	96/08/05
0008	O3400	2420	96/07/31
0009	O3500	7460	96/07/31

~ ([PROG]) ([DIR +]) ([OPRT]) ~

- 5 Press soft key **[(OPRT)]**.
- 6 Set the number of the desired file number with soft key **[F SRH]**. Then, start the search by pressing soft key **[EXEC]**. If found, the file is displayed at the top of the directory screen.

When a search is made for file number 19



DIRECTORY (M-CARD)			O0034 N00045
No.	FILE NAME	COMMENT	
0019	O1000	(MAIN PROGRAM)	
0020	O1010	(SUBPROGRAM-1)	
0021	O1020	(COMMENT)	
0022	O1030	(COMMENT)	

~ ~

([F SRH]) ([F READ]) ([N READ]) ([PUNCH]) ([DELETE])

Reading a file

Procedure

- 1 Press the EDIT switch on the machine operator's panel.
- 2 Press function key  .
- 3 Press the rightmost soft key  (next-menu key).
- 4 Press soft key **[CARD]**. Then, the screen shown below is displayed.

DIRECTORY (M-CARD)			O0034 N00045
No.	FILE NAME	SIZE	DATE
0001	O1000	123456	96/07/10
0002	O1001	8458	96/07/30
0003	O0002	3250	96/07/30
0004	O2000	73456	96/07/31
0005	O2001	3444	96/07/31
0006	O3001	8483	96/08/02
0007	O3300	406	96/08/05
0008	O3400	2420	96/07/31
0009	O3500	7460	96/07/31

~ ([PROG]) ([DIR +]) ([OPRT]) ~

- 5 Press soft key **[(OPRT)]**.
- 6 To specify a file number, press soft key **[F READ]**. The screen shown below is displayed.

([F SRH]) ([F READ]) ([N READ]) ([PUNCH]) ([DELETE])

DIRECTORY (M-CARD)		O0001 N00010
No.	FILE NAME	COMMENT
0019	O1000	(MAIN PROGRAM)
0020	O1010	(SUBPROGRAM-1)
0021	O1030	(COMMENT)

~ READ FILE NAME=20 PROGRAM No.=120 > ~

EDIT *** **** * * * * * 15:40:21

([F NAME]) ([O SET]) ([STOP]) ([CAN]) ([EXEC])

- 7 Enter file number 20 from the MDI panel, then set the file number by pressing soft key **[F SET]**. Next, enter program number 120, then set the program number by pressing soft key **[O SET]**. Then, press soft key **[EXEC]**.
 - File number 20 is registered as O0120 in the CNC.
 - Set a program number to register a read file with a separate O number. If no program number is set, the O number in the file name column is registered.

- 8 To specify a file with its file name, press soft key **[N READ]** in step 6 above. The screen shown below is displayed.

DIRECTORY (M-CARD)		O0001 N00010
No.	FILE NAME	COMMENT
0012	O0050	(MAIN PROGRAM)
0013	TESTPRO	(SUB PROGRAM-1)
0014	O0060	(MACRO PROGRAM)

~



READ	FILE NAME =TESTPRO
	PROGRAM No. =1230
>	
EDIT *** **** ** *	15:40:21
(F NAME)	(O SET)
(STOP)	(CAN)
(EXEC)	

~

- 9 To register file name TESTPRO as O1230, enter file name TESTPRO from the MDI panel, then set the file name with soft key **[F NAME]**. Next, enter program number 1230, then set the program number with soft key **[O SET]**. Then, press soft key **[EXEC]**.

Writing a file

Procedure

- 1 Press the EDIT switch on the machine operator's panel.
- 2 Press function key .
- 3 Press the rightmost soft key  (next-menu key).
- 4 Press soft key **[CARD]**. The screen shown below is displayed.

DIRECTORY (M-CARD)			O0034 N00045
No.	FILE NAME	SIZE	DATE
0001	O1000	123456	96/07/10
0002	O1001	8458	96/07/30
0003	O0002	3250	96/07/30
0004	O2000	73456	96/07/31
0005	O2001	3444	96/07/31
0006	O3001	8483	96/08/02
0007	O3300	406	96/08/05
0008	O3400	2420	96/07/31
0009	O3500	7460	96/07/31

~ ([PROG]) ([]) ([DIR +]) ([]) ([(OPRT)]) ~

- 5 Press soft key **[(OPRT)]**.
- 6 Press soft key **[PUNCH]**.
- 7 Enter a desired O number from the MDI panel, then set the program number with soft key **[O SET]**.
When soft key **[EXEC]** is pressed after the setting shown below has been made, for example, the file is written under program number O1230.

~ PUNCH FILE NAME =
PROGRAM No. =1230
>
EDIT *** **** * * * * 15:40:21
([F NAME]) ([O SET]) ([STOP]) ([CAN]) ([EXEC]) ~

- 8 In the same way as for O number setting, enter a desired file name from the MDI panel, then set the file name with soft key **[F SET]**.
When soft key **[EXEC]** is pressed after the setting shown below has been made, for example, the file is written under program number O1230 and file name ABCD12.

~ PUNCH FILE NAME =ABCD12
PROGRAM No. =1230
>
EDIT *** **** * * * * 15:40:21
([F NAME]) ([O SET]) ([STOP]) ([CAN]) ([EXEC]) ~

([F SRH]) ([F READ]) ([N READ]) ([PUNCH]) ([DELETE])



Explanations

- **Registering the same file name** When a file having the same name is already registered in the memory card, the existing file will be overwritten.
- **Writing all programs** To write all programs, set program number = -9999. If no file name is specified in this case, file name PROGRAM.ALL is used for registration.
- **File name restrictions** The following restrictions are imposed on file name setting:

<File name setting> × × × × × × × × . □ □ □
 ↑ ↑
 Not longer than Extension not longer
 8 characters than 3 characters

Deleting a file

Procedure

- 1 Press the EDIT switch on the machine operator's panel.
- 2 Press function key  .
- 3 Press the rightmost soft key  (next-menu key).
- 4 Press soft key **[CARD]**. The screen shown below is displayed.

DIRECTORY (M-CARD)			O0034 N00045
No.	FILE NAME	SIZE	DATE
0001	O1000	123456	96/07/10
0002	O1001	8458	96/07/30
0003	O0002	3250	96/07/30
0004	O2000	73456	96/07/31
0005	O2001	3444	96/07/31
0006	O3001	8483	96/08/02
0007	O3300	406	96/08/05
0008	O3400	2420	96/07/31
0009	O3500	7460	96/07/31

~ ([PROG]) ([DIR +]) ([(OPRT)]) ~

- 5 Press soft key **[(OPRT)]**.
- 6 Set the number of the desired file with soft key **[DELETE]**, then press soft key **[EXEC]**. The file is deleted, and the directory screen is displayed again.

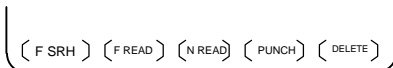

When file number 21 is deleted

DIRECTORY (M-CARD)			O0034 N00045
No.	FILE NAME		COMMENT
0019	O1000		(MAIN PROGRAM)
0020	O1010		(SUBPROGRAM-1)
0021	O1020		(COMMENT)
0022	O1030		(COMMENT)

~ ~

File name O1020 is deleted.

DIRECTORY (M-CARD)			O0034 N00045
No.	FILE NAME		COMMENT
0019	O1000		(MAIN PROGRAM)
0020	O1010		(SUBPROGRAM-1)
0021	O1020		(COMMENT)
0022	O1030		(COMMENT)

~ ~



File number 21 is assigned to the next file name.

Batch input/output with a memory card

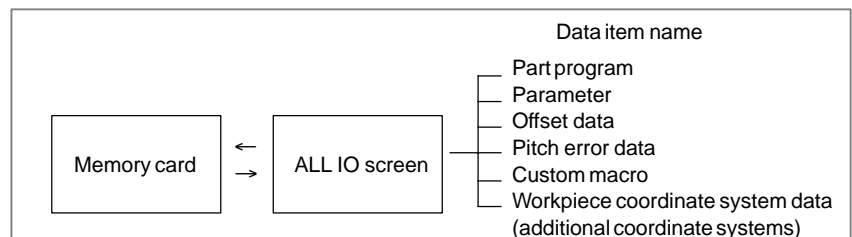
On the ALL IO screen, different types of data including part programs, parameters, offset data, pitch error data, custom macros, and workpiece coordinate system data can be input and output using a memory card; the screen for each type of data need not be displayed for input/output.





Procedure

- 1 Press the EDIT switch on the machine operator's panel.
- 2 Press function key .
- 3 Press the rightmost soft key  (next-menu key) several times.
- 4 Press soft key **[ALL IO]**. The screen shown below is displayed.

READ/PUNCH (PROGRAM)						O0001 N0001								
No.	FILE NAME	SIZE				DATE								
*0001	O0222	332010				96-04-06								
*0002	O1003	334450				96-05-04								
*0003	MACROVAR.DAT	653400				96-05-12								
*0004	O0002	341205				96-05-13								
[PROGRAM]														
*O0001	O0002	O0003	O0005	O0100	O0020									
*O0006	O0004	O0110	O0200	O2200	O0441									
*O0330														
>														
EDIT	***	****	***	****	10:07:37									
(PROG)	(PARAM)	(OFFSET)	()	(OPRT)



Upper part: Directory of files on the memory card

Lower part: Directory of registered programs

- 5 With cursor keys  and , the user can choose between upper part scrolling and lower part scrolling. (An asterisk (*) displayed at the left edge indicates the part for which scrolling is possible.)

 : Used for memory card file directory scrolling.

 : Used for program directory scrolling.

- 6 With page keys  and , scroll through the file directory or program directory.

Explanations

- Each data item

When this screen is displayed, the program data item is selected. The soft keys for other screens are displayed by pressing the rightmost soft key  (next-menu key). Soft key **[M-CARD]** represents a separate memory card function for saving and restoring system RAM data. (See Section 8.10.7.)

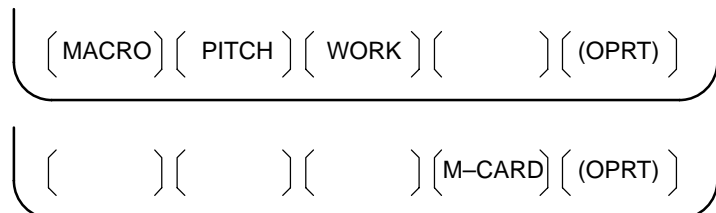

When a data item other than program is selected, the screen displays only a file directory.

A data item is indicated, in parentheses, on the title line.

READ/PUNCH (PARAMETER)		O0001	N00001
No.	FILE NAME	SIZE	DATE
0001	O0222	32010	96/04/06
0002	O1003	4450	96/05/04
0003	MACROVAR.DAT	653400	96/05/12
0004	O0003	4610	96/05/04
0005	O0001	4254	96/06/04
0006	O0002	750	96/06/04
0007	CNCPARAM.DAT	34453	96/06/04

- Program directory display

Program directory display does not match bit 0 (NAM) of parameter No. 3107, or bit 4 (SOR) of parameter No. 3107.

- Using each function

Display the following soft keys with soft key **[(OPRT)]**.



The operation of each function is the same as on the directory (memory card) screen. Soft key **[O SET]**, used for program number setting, and the “PROGRAM NUMBER =” indication are not displayed for data items other than program.

[F SRH]: Finds a specified file number.

[F READ]: Reads a specified file number.

[PUNCH]: Writes a file.

[N READ]: Reads a file under a specified file name.

[DELETE]: Deletes a specified file number.

NOTE

With a memory card, RMT mode operation and the subprogram call function (based on the M198 command) cannot be used.

File format and error messages

File format

All files that are read from and written to a memory card are of text format. The format is described below.

A file starts with % or LF, followed by the actual data. A file always ends with %. In a read operation, data between the first % and the next LF is skipped. Each block ends with an LF, not a semicolon (;).

- LF: 0A (hexadecimal) of ASCII code
- When a file containing lowercase letters, kana characters, and several special characters (such as \$, ¥, and !) is read, those letters and characters are ignored.

Example:

```
%
O0001(MEMORY CARD SAMPLE FILE)
G17 G49 G97
G92X-11.3Y2.33
.
.
M30
%
```

- ASCII code is used for input/output, regardless of the setting parameter (ISO/EIA).
- Bit 3 (NCR) of parameter No. 0100 can be used to specify whether the end of block code (EOB) is output as “LF” only, or as “LF, CR, CR.”

Error messages

If an error occurs during memory card input/output, a corresponding error message is displayed.

```

~
0028  O0003                               7382  96-06-14
M-CARD ERROR                               ××××
FILE No. =      1      PROGRAM No. =13
>_
EDIT  ***  ****  ***  ****                15:40:21
( F SET ) ( O SET ) ( STOP ) ( CAN ) ( EXEC )
~

```

× × × × represents a memory card error code.

Memory card error codes

Code	Meaning
102	The memory card does not have sufficient free space.
105	No memory card is mounted.
106	A memory card is already mounted.
110	The specified directory cannot be found.
111	There are too many files under the root directory to allow a directory to be added.
114	The specified file cannot be found.
115	The specified file is protected.
117	The file has not yet been opened.
118	The file is already open.
119	The file is locked.
122	The specified file name is invalid.
124	The extension of the specified file is invalid.
129	A non-corresponding function was specified.
130	The specification of a device is invalid.
131	The specification of a pathname is invalid.
133	Multiple files are open at the same time.
135	The device is not formatted.
140	The file has the read/write disabled attribute.

9 EDITING PROGRAMS

General

This chapter describes how to edit programs registered in the CNC. Editing includes the insertion, modification, deletion, and replacement of words. Editing also includes deletion of the entire program and automatic insertion of sequence numbers. The extended part program editing function can copy, move, and merge programs. This chapter also describes program number search, sequence number search, word search, and address search, which are performed before editing the program.

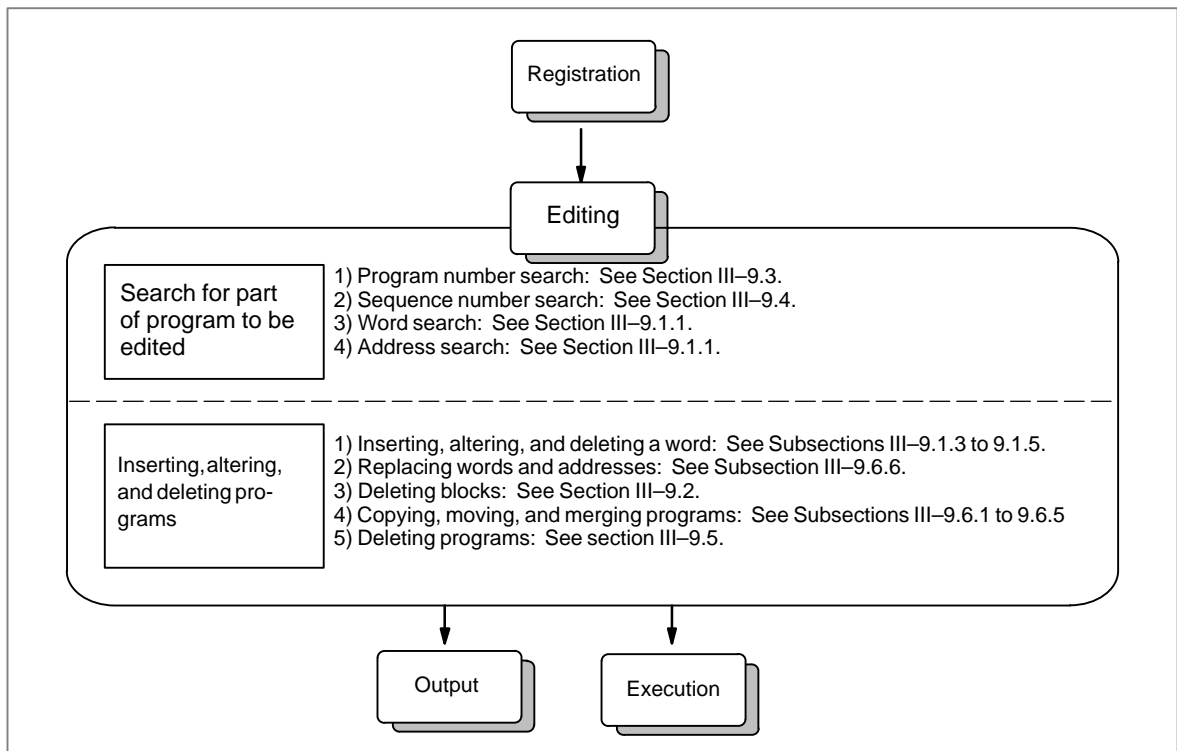

9.1 INSERTING, ALTERING AND DELETING A WORD

This section outlines the procedure for inserting, modifying, and deleting a word in a program registered in memory.

Procedure for inserting, altering and deleting a word

- 1 Select **EDIT** mode.
- 2 Press  .
- 3 Select a program to be edited.
If a program to be edited is selected, perform the operation 4.
If a program to be edited is not selected, search for the program number.
- 4 Search for a word to be modified.
·Scan method
·Word search method
- 5 Perform an operation such as altering, inserting, or deleting a word.

Explanation

- **Concept of word and editing unit**

A word is an address followed by a number. With a custom macro, the concept of word is ambiguous.

So the editing unit is considered here.

The editing unit is a unit subject to alteration or deletion in one operation.

In one scan operation, the cursor indicates the start of an editing unit.

An insertion is made after an editing unit.

Definition of editing unit

- (i) Program portion from an address to immediately before the next address
- (ii) An address is an alphabet, **IF**, **WHILE**, **GOTO**, **END**, **DO=**, or ; (**EOB**).

According to this definition, a word is an editing unit.

The word “word,” when used in the description of editing, means an editing unit according to the precise definition.

WARNING

The user cannot continue program execution after altering, inserting, or deleting data of the program by suspending machining in progress by means of an operation such as a single block stop or feed hold operation during program execution. If such a modification is made, the program may not be executed exactly according to the contents of the program displayed on the screen after machining is resumed. So, when the contents of memory are to be modified by part program editing, be sure to enter the reset state or reset the system upon completion of editing before executing the program.

9.1.1 Word Search

A word can be searched for by merely moving the cursor through the text (scanning), by word search, or by address search.

Procedure for scanning a program

- 1 Press the cursor key 











The cursor moves forward word by word on the screen; the cursor is displayed at a selected word.
- 2 Press the cursor key 

The cursor moves backward word by word on the screen; the cursor is displayed at a selected word.

Example) When Z1250.0 is scanned

```

Program                                O0050 N01234
O0050 ;
N01234 X100.0 Z1250.0 ;
S12 ;
N56789 M03 ;
M02 ;
%
```

- 3 Holding down the cursor key  or  scans words continuously.
- 4 The first word of the next block is searched for when the cursor key  is pressed.
- 5 The first word of the previous block is searched for when the cursor key  is pressed.
- 6 Holding down the cursor key  or  moves the cursor to the head of a block continuously.
- 7 Pressing the page key  displays the next page and searches for the first word of the page.
- 8 Pressing the page key  displays the previous page and searches for the first word of the page.
- 9 Holding down the page key  or  displays one page after another.

Procedure for searching a word

Example) of Searching for S12

<pre> PROGRAM O0050 N01234 O0050 ; N01234 X100.0 Z1250.0 ; ← S12 ; ← N56789 M03 ; M02 ; %</pre>	<p>N01234 is being searched for/ scanned currently.</p> <p>S12 is searched for.</p>
--	---

- 1 Key in address S .

- 2 Key in 1 2 .
 - S12 cannot be searched for if only S1 is keyed in.
 - S09 cannot be searched for by keying in only S9. To search for S09, be sure to key in S09.

- 3 Pressing the **[SRH↓]** key starts search operation. Upon completion of search operation, the cursor is displayed at S12. Pressing the **[SRH↑]** key rather than the **[SRH↓]** key performs search operation in the reverse direction.

Procedure for searching an address

Example) of Searching for M03

<pre> PROGRAM O0050 N01234 O0050 ; N01234 X100.0 Z1250.0 ; ← S12 ; N56789 M03 ; ← M02 ; %</pre>	<p>N01234 is being searched for/ scanned currently.</p> <p>M03 is searched for.</p>
--	---

- 1 Key in address M .

- 2 Press the **[SRH↓]** key. Upon completion of search operation, the cursor is displayed at M03. Pressing the **[SRH↑]** key rather than the **[SRH↓]** key performs search operation in the reverse direction.

Alarm

Alarm number	Description
71	The word or address being searched for was not found.

9.1.2 Heading a Program

The cursor can be jumped to the top of a program. This function is called heading the program pointer. This section describes the three methods for heading the program pointer.

Procedure for Heading a Program

Method 1

- 1 Press  when the program screen is selected in EDIT mode. When the cursor has returned to the start of the program, the contents of the program are displayed from its start on the screen.

Method 2

Search for the program number.

- 1 Press address , when a program screen is selected in the **MEMORY** or **EDIT** mode.
- 2 Input a program number.
- 3 Press the soft key [**O SRH**].

Method 3

- 1 Select **MEMORY** or **EDIT** mode.
- 2 Press .
- 3 Press the **[(OPRT)]** key.
- 4 Press the **[REWIND]** key.

9.1.3 Inserting a Word

Procedure for inserting a word

- 1 Search for or scan the word immediately before a word to be inserted.
- 2 Key in an address to be inserted.
- 3 Key in data.
- 4 Press the  key.

Example of Inserting T15

Procedure

- 1 Search for or scan Z1250.

<pre> Program O0050 N01234 O0050 ; N01234 X100.0 Z1250.0 ; ← S12 ; N56789 M03 ; M02 ; %</pre>	Z1250.0 is searched for/ scanned.
---	---

- 2 Key in    .

- 3 Press the  key.

<pre> Program O0050 N01234 O0050 ; N01234 X100.0 Z1250.0 T15 ; ← S12 ; N56789 M03 ; M02 ; %</pre>	T15 is inserted.
---	------------------

9.1.4 Altering a Word

Procedure for altering a word

- 1 Search for or scan a word to be altered.
- 2 Key in an address to be inserted.
- 3 Key in data.
- 4 Press the  key.

Example of changing T15 to M15

Procedure

- 1 Search for or scan T15.

<pre> Program O0050 N01234 O0050 ; N01234 X100.0 Z1250.0 T15 ; ← S12 ; N56789 M03 ; M02 ; %</pre>	<p>T15 is searched for/scanned.</p>
---	---

- 2 Key in    .

- 3 Press the  key.

<pre> Program O0050 N01234 O0050 ; N1234 X100.0 Z1250.0 M15 ; ← S12 ; N5678 M03 ; M02 ; %</pre>	<p>T15 is changed to M15.</p>
---	-----------------------------------

9.1.5 Deleting a Word

Procedure for deleting a word

- 1 Search for or scan a word to be deleted.
- 2 Press the  key.

Example of deleting X100.0

Procedure

- 1 Search for or scan X100.0.

<pre> Program O0050 N01234 O0050 ; N01234 X100.0 Z1250.0 M15 ; S12 ; N56789 M03 ; M02 ; %</pre>	<p>X100.0 is searched for/ scanned.</p>
---	---

- 2 Press the  key.

<pre> Program O0050 N01234 O0050 ; N01234 Z1250.0 M15 ; S12 ; N56789 M03 ; M02 ; %</pre>	<p>X100.0 is deleted.</p>
---	---------------------------

9.2 DELETING BLOCKS

A block or blocks can be deleted in a program.

9.2.1 Deleting a Block

The procedure below deletes a block up to its EOB code; the cursor advances to the address of the next word.

Procedure for deleting a block

- 1 Search for or scan address N for a block to be deleted.
- 2 Key in .
- 3 Press the .

Example of deleting a block of No. 1234

Procedure

- 1 Search for or scan N01234.

<pre> Program O0050 N01234 O0050 ; N01234 Z1250.0 M15 ; ← S12 ; N56789 M03 ; M02 ; %</pre>	<p>N01234 is searched for/ scanned.</p>
--	---

- 2 Key in .

- 3 Press the key.

<pre> Program O0050 N01234 O0050 ; ← S12 ; N56789 M03 ; M02 ; %</pre>	<p>Block containing N01234 has been deleted.</p>
--	--

9.2.2 Deleting Multiple Blocks

The blocks from the currently displayed word to the block with a specified sequence number can be deleted.

Procedure for deleting multiple blocks

- 1 Search for or scan a word in the first block of a portion to be deleted.
- 2 Key in address N .
- 3 Key in the sequence number for the last block of the portion to be deleted.
- 4 Press the DELETE key.

Example of deleting blocks from a block containing N01234 to a block containing N56789

Procedure

- 1 Search for or scan N01234.

<pre> Program O0050 N01234 O0050 ; N01234 Z1250.0 M15 ; ← S12 ; N56789 M03 ; M02 ; %</pre>	N01234 is searched for/ scanned.
--	--

- 2 . Key in N 5 6 7 8 9 .

<pre> Program O0050 N01234 O0050 ; N01234 Z1250.0 M15 ; } ← S12 ; N56789 M03 ; M02 ; %</pre>	Underlined part is de- leted.
--	-------------------------------------

- 3 Press the DELETE key.

<pre> Program O0050 N01234 O0050 ; ← M02 ; %</pre>	Blocks from block containing N01234 to block containing N56789 have been deleted.
---	--



CAUTION

When there are too many blocks to be deleted, a P/S alarm (No. 070) may be generated. If this happens, reduce the number of blocks to be deleted.

9.3 PROGRAM NUMBER SEARCH

When memory holds multiple programs, a program can be searched for. There are three methods as follows.

Procedure for program number search

- Method 1**
- 1 Select **EDIT** or **MEMORY** mode.
 - 2 Press  to display the program screen.
 - 3 Key in address .
 - 4 Key in a program number to be searched for.
 - 5 Press the **[O SRH]** key.
 - 6 Upon completion of search operation, the program number searched for is displayed in the upper-right corner of the CRT screen. If the program is not found, P/S alarm No. 71 occurs.
- Method 2**
- 1 Select **EDIT** or **MEMORY** mode.
 - 2 Press  to display the program screen.
 - 3 Press the **[O SRH]** key.
In this case, the next program in the directory is searched for.
- Method 3**
- This method searches for the program number (0001 to 0015) corresponding to a signal on the machine tool side to start automatic operation. Refer to the relevant manual prepared by the machine tool builder for detailed information on operation.
- 1 Select **MEMORY** mode.
 - 2 Set the reset state (*1)
 - The reset state is the state where the LED for indicating that automatic operation is in progress is off. (Refer to the relevant manual of the machine tool builder.)
 - 3 Set the program number selection signal on the machine tool side to a number from 01 to 15.
 - If the program corresponding to a signal on the machine tool side is not registered, P/S alarm (No. 059) is raised.
 - 4 Press the cycle start button.
 - When the signal on the machine tool side represents 00, program number search operation is not performed.

Alarm

Alarm No.	Contents
59	The program with the selected number cannot be searched during external program number search.
71	The specified program number was not found during program number search.



9.4 SEQUENCE NUMBER SEARCH

Sequence number search operation is usually used to search for a sequence number in the middle of a program so that execution can be started or restarted at the block of the sequence number.

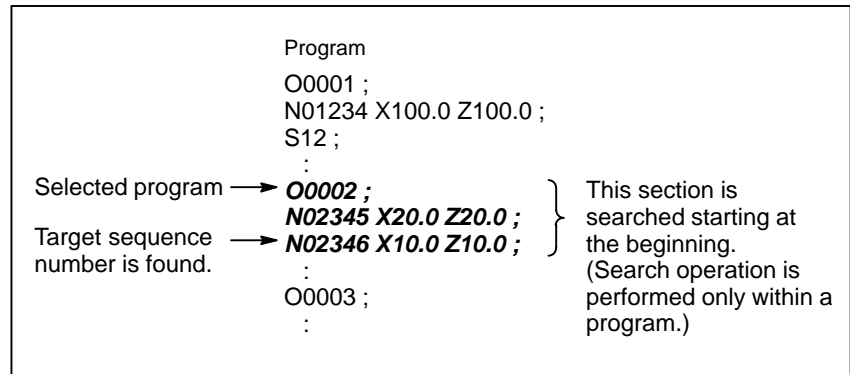
Example) Sequence number 02346 in a program (O0002) is searched for.



Procedure for sequence number search

- 1 Select **MEMORY** mode.
- 2 Press  .
- 3 · If the program contains a sequence number to be searched for, perform the operations 4 to 7 below.
· If the program does not contain a sequence number to be searched for, select the program number of the program that contains the sequence number to be searched for.
- 4 Key in address  .
- 5 Key in a sequence number to be searched for.
- 6 Press the **[N SRH]** key.
- 7 Upon completion of search operation, the sequence number searched for is displayed in the upper-right corner of the CRT screen.
If the specified sequence number is not found in the program currently selected, P/S alarm (No. 060) occurs.

Explanations

• **Operation during Search**

Those blocks that are skipped do not affect the CNC. This means that the data in the skipped blocks such as coordinates and M, S, and T codes does not alter the CNC coordinates and modal values.

So, in the first block where execution is to be started or restarted by using a sequence number search command, be sure to enter required M, S, and T codes and coordinates. A block searched for by sequence number search usually represents a point of shifting from one process to another. When a block in the middle of a process must be searched for to restart execution at the block, specify M, S, and T codes, G codes, coordinates, and so forth as required from the MDI after closely checking the machine tool and CNC states at that point.

• **Checking during search**

During search operation, the following checks are made:

- Optional block skip
- P/S alarm (No. 003 to 010)

Restrictions

• **Searching in sub-program**

During sequence number search operation, M98Pxxxx (subprogram call) is not executed. So an P/S alarm (No. 060) is raised if an attempt is made to search for a sequence number in a subprogram called by the program currently selected.

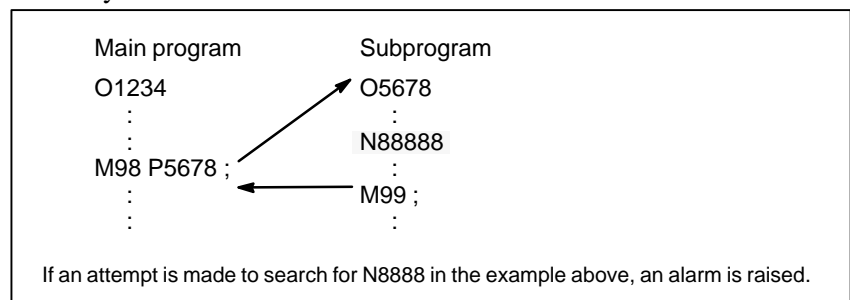

Alarm

Alarm No.	Contents
60	Command sequence number was not found in the sequence number search.



9.5 DELETING PROGRAMS

Programs registered in memory can be deleted, either one program by one program or all at once. Also, More than one program can be deleted by specifying a range.

9.5.1 Deleting One Program

A program registered in memory can be deleted.



Procedure for deleting one program

- 1 Select the **EDIT** mode.
 - 2 Press  to display the program screen.
 - 3 Key in address  .
 - 4 Key in a desired program number.
 - 5 Press the  key.
The program with the entered program number is deleted.
-

9.5.2 Deleting All Programs

All programs registered in memory can be deleted.



Procedure for deleting all programs

- 1 Select the **EDIT** mode.
- 2 Press  to display the program screen.
- 3 Key in address  .
- 4 Key in -9999.
- 5 Press edit key  to delete all programs.

9.5.3 Deleting More Than One Program by Specifying a Range

Programs within a specified range in memory are deleted.

Procedure for deleting more than one program by specifying a range

- 1 Select the **EDIT** mode.
- 2 Press  to display the program screen.
- 3 Enter the range of program numbers to be deleted with address and numeric keys in the following format:
OXXXX,OYYYY
where XXXX is the starting number of the programs to be deleted and YYYYY is the ending number of the programs to be deleted.
- 4 Press edit key  to delete programs No. XXXX to No. YYYYY.

9.6 EXTENDED PART PROGRAM EDITING FUNCTION

With the extended part program editing function, the operations described below can be performed using soft keys for programs that have been registered in memory.

Following editing operations are available :

- All or part of a program can be copied or moved to another program.
- One program can be merged at free position into other programs.
- A specified word or address in a program can be replaced with another word or address.

9.6.1 Copying an Entire Program

A new program can be created by copying a program.

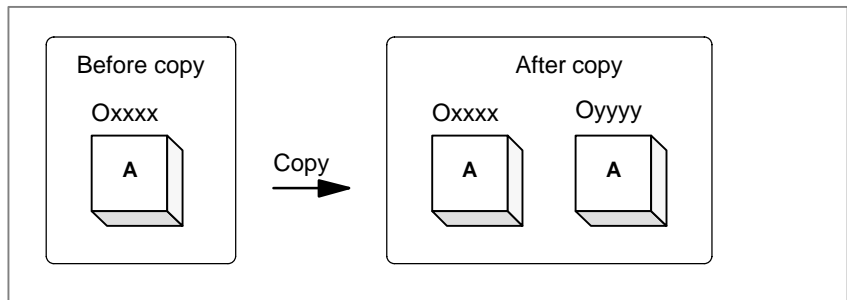
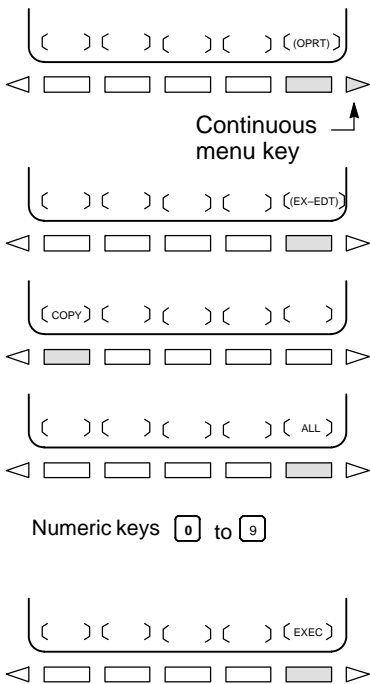

Fig. 9.6.1 Copying an Entire Program

In Fig. 9.6.1, the program with program number xxxx is copied to a newly created program with program number yyyy. The program created by copy operation is the same as the original program except the program number.

Procedure of copying an entire program

- 1 Enter the **EDIT** mode.
- 2 Press function key .
- 3 Press soft key **[(OPRT)]**.
- 4 Press the continuous menu key.
- 5 Press soft key **[EX-EDT]**.
- 6 Check that the screen for the program to be copied is selected and press soft key **[COPY]**.
- 7 Press soft key **[ALL]**.
- 8 Enter the number of the new program (with only numeric keys) and press the key.
- 9 Press soft key **[EXEC]**.



9.6.2 Copying Part of a Program

A new program can be created by copying part of a program.

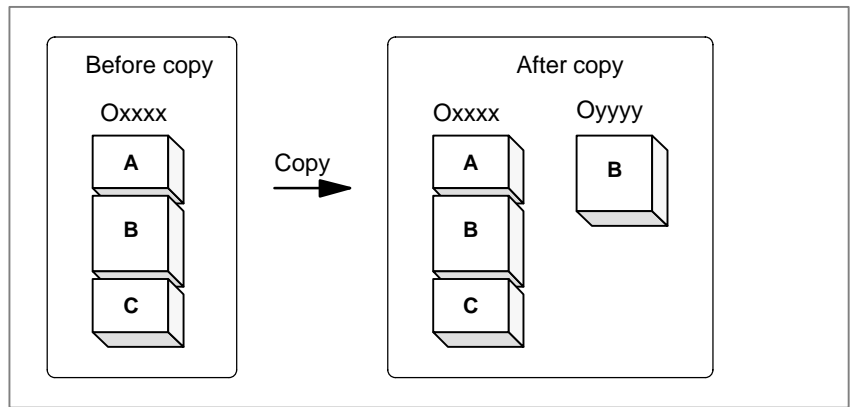
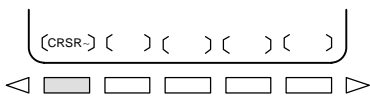

Fig. 9.6.2 Copying Part of a Program

In Fig. 9.6.2, part B of the program with program number xxxx is copied to a newly created program with program number yyyy. The program for which an editing range is specified remains unchanged after copy operation.

Procedure for copying part of a program



1 Perform steps 1 to 6 in subsection III-9.6.1.

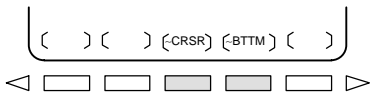

2 Move the cursor to the start of the range to be copied and press soft key [CRSR~].

3 Move the cursor to the end of the range to be copied and press soft key [~CRSR] or [~BTM] (in the latter case, the range to the end of the program is copied regardless of the position of the cursor).

Numeric keys 0 to 9

4 Enter the number of the new program (with only numeric keys) and press the key.

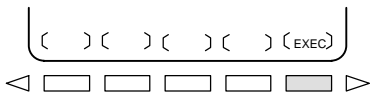

5 Press soft key [EXEC].

9.6.3 Moving Part of a Program

A new program can be created by moving part of a program.

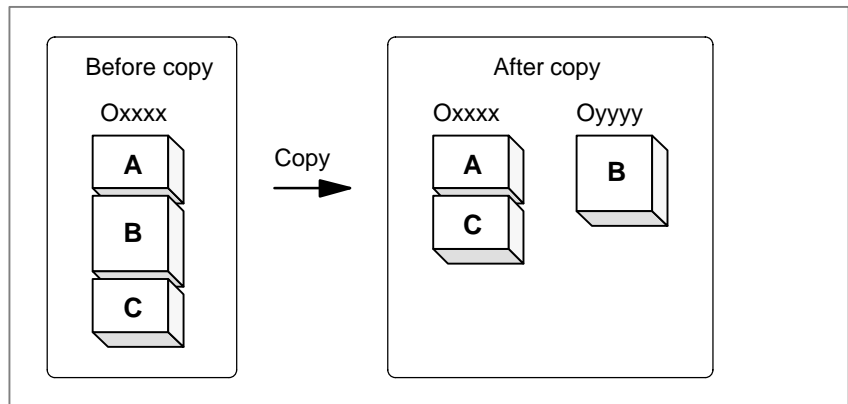
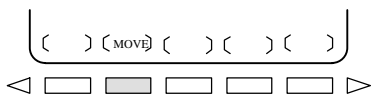

Fig. 9.6.3 Moving Part of a Program

In Fig. 9.6.3, part B of the program with program number xxxx is moved to a newly created program with program number yyyy; part B is deleted from the program with program number xxxx.

Procedure for moving part of a program



1 Perform steps 1 to 5 in subsection III-9.6.1.

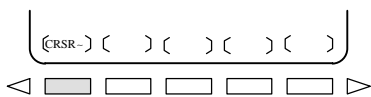

2 Check that the screen for the program to be moved is selected and press soft key **[MOVE]**.

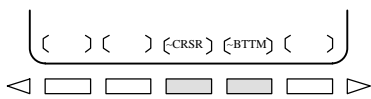

3 Move the cursor to the start of the range to be moved and press soft key **[CRSR~]**.

4 Move the cursor to the end of the range to be moved and press soft key **[-CRSR]** or **[-BTM]** (in the latter case, the range to the end of the program is copied regardless of the position of the cursor).

Numeric keys **0** to **9**

5 Enter the number of the new program (with only numeric keys) and press the **INPUT** key.

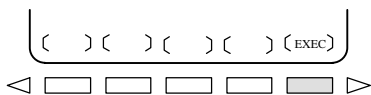

6 Press soft key **[EXEC]**.

9.6.4 Merging a Program

Another program can be inserted at an arbitrary position in the current program.

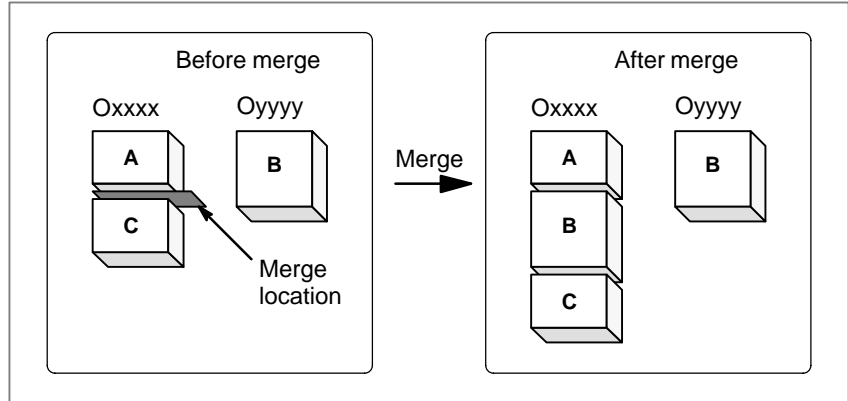
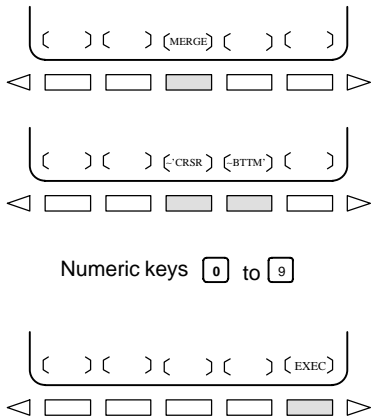

Fig. 9.6.4 Merging a program at a specified location

In Fig. 9.6.4, the program with program number XXXX is merged with the program with program number YYYYY. The OYYYY program remains unchanged after merge operation.

Procedure for merging a program



- 1 Perform steps 1 to 5 in subsection III-9.6.1.
- 2 Check that the screen for the program to be edited is selected and press soft key **[MERGE]**.
- 3 Move the cursor to the position at which another program is to be inserted and press soft key **[~'CRSR]** or **[~BTM']** (in the latter case, the end of the current program is displayed).
- 4 Enter the number of the program to be inserted (with only numeric keys) and press the **INPUT** key.
- 5 Press soft key **[EXEC]**.
The program with the number specified in step 4 is inserted before the cursor positioned in step 3.

9.6.5 Supplementary Explanation for Copying, Moving and Merging

Explanations

- **Setting an editing range**

The setting of an editing range start point with **[CRSR~]** can be changed freely until an editing range end point is set with **[~CRSR]** or **[~BTM]**. If an editing range start point is set after an editing range end point, the editing range must be reset starting with a start point.

The setting of an editing range start point and end point remains valid until an operation is performed to invalidate the setting.

One of the following operations invalidates a setting:

- An edit operation other than address search, word search/scan, and search for the start of a program is performed after a start point or end point is set.
- Processing is returned to operation selection after a start point or end point is set.

- **Without specifying a program number**

In copying program and moving program, if **[EXEC]** is pressed without specifying a program number after an editing range end point is set, a program with program number O0000 is registered as a work program. This O0000 program has the following features:

- The program can be edited in the same way as a general program. (Do not run the program.)
- If a copy or move operation is newly performed, the previous information is deleted at execution time, and newly set information (all or part of the program) is re-registered. (In merge operation, the previous information is not deleted.) However, the program, when selected for foreground operation, cannot be re-registered in the background. (A BP/S140 alarm is raised.) When the program is re-registered, a free area is produced. Delete such a free area with the

 key.

- When the program becomes unnecessary, delete the program by a normal editing operation.

- **Editing when the system waiting for a program number to be entered**



When the system is waiting for a program number to be entered, no edit operation can be performed.

Restrictions

- **Number of digits for program number**

If a program number is specified by 5 or more digits, a format error is generated.

Alarm

Alarm No.	Contents
70	Memory became insufficient while copying or inserting a program. Copy or insertion is terminated.
101	The power was interrupted during copying, moving, or inserting a program and memory used for editing must be cleared. When this alarm occurs, press the key  while pressing function key  . Only the program being edited is deleted.

9.6.6 Replacement of Words and Addresses

Replace one or more specified words.
Replacement can be applied to all occurrences or just one occurrence of specified words or addresses in the program.

Procedure for change of words or addresses

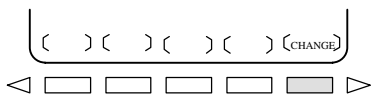

1 Perform steps 1 to 5 in subsection 9.6.1.

2 Press soft key **[CHANGE]**.

3 Enter the word or address to be replaced.

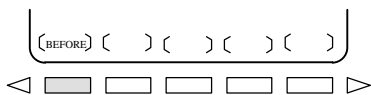

4 Press soft key **[BEFORE]**.

5 Enter the new word or address.

6 Press soft key **[AFTER]**.

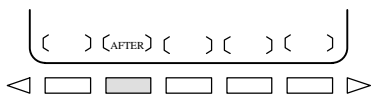

7 Press soft key **[EXEC]** to replace all the specified words or addresses after the cursor.

Press soft key **[1-EXEC]** to search for and replace the first occurrence of the specified word or address after the cursor.

Press soft key **[SKIP]** to only search for the first occurrence of the specified word or address after the cursor.

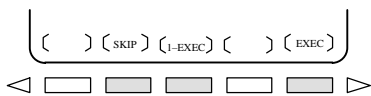

EXAMPLES

- Replace X100 with Z200

[CHANGE] X 1 0 0 [BEFORE] Z 2 0 0
[AFTER] [EXEC]

- Replace X100Z200 with X30

[CHANGE] X 1 0 0 Z 2 0 0 [BEFORE]
X 3 0 [AFTER] [EXEC]

- Replace IF with WHILE

[CHANGE] I F [BEFORE] W H I L E
[AFTER] [EXEC]

- Replace X with ,C10

[CHANGE] X [BEFOR] , C 1 0 [AFTER] [EXEC]

Explanation

- Replacing custom macros

The following custom macro words are replaceable:

IF, WHILE, GOTO, END, DO, BPRNT, DPRNT, POPEN, PCLOS

The abbreviations of custom macro words can be specified.

When abbreviations are used, however, the screen displays the abbreviations as they are key input, even after soft key **[BEFORE]** and **[AFTER]** are pressed.

Restrictions

- **The number of characters for replacement** Up to 15 characters can be specified for words before or after replacement. (Sixteen or more characters cannot be specified.)
- **The characters for replacement** Words before or after replacement must start with a character representing an address. (A format error occurs.)

9.7 EDITING OF CUSTOM MACROS

Unlike ordinary programs, custom macro programs are modified, inserted, or deleted based on editing units.

Custom macro words can be entered in abbreviated form.

Comments can be entered in a program.

Refer to the section 10.1 for the comments of a program.

Explanations

- **Editing unit**

When editing a custom macro already entered, the user can move the cursor to each editing unit that starts with any of the following characters and symbols:

(a) Address

(b) # located at the start of the left side of a substitution statement

(c) /, (=, and ;

(d) First character of IF, WHILE, GOTO, END, DO, POPEN, BPRNT, DPRNT and PCLOS

On the CRT screen, a blank is placed before each of the above characters and symbols.

(Example) Head positions where the cursor is placed

```

N001 X-#100 :
#1 =123 :
N002 /2 X[12/#3] :
N003 X-SQRT[#3/3*] [#4+1] :
N004 X-#2 Z#1 :
N005 #5 =1+2-#10 :
IF[#1NE0] GOTO10 :
WHILE[#2LE5] DO1 :
#[200+#2] =#2*10 :
#2 =#2+1 :
END1 :

```

- **Abbreviations of custom macro word**

When a custom macro word is altered or inserted, the first two characters or more can replace the entire word.

Namely,

WHILE → WH	GOTO → GO	XOR → XO	AND → AN
SIN → SI	ASIN → AS	COS → CO	ACOS → AC
TAN → TA	ATAN → AT	SQRT → SQ	ABS → AB
BCD → BC	BIN → BI	FIX → FI	FUP → FU
ROUND → RO	END → EN	POPEN → PO	BPRNT → BP
DPRNT → DP	PCLOS → PC	EXP → EX	THEN → TH

(Example) Keying in

WH [AB [#2] LE RO [#3]]

has the same effect as

WHILE [ABS [#2] LE ROUND [#3]]

The program is also displayed in this way.

9.8 BACKGROUND EDITING

Editing a program while executing another program is called background editing. The method of editing is the same as for ordinary editing (foreground editing).

A program edited in the background should be registered in foreground program memory by performing the following operation:

During background editing, all programs cannot be deleted at once.

Procedure for background editing

- 1 Enter **EDIT** or **MEMORY** mode.
Memory mode is allowed even while the program is being executed.
- 2 Press function key  .
- 3 Press soft key **[(OPRT)]**, then press soft key **[BG-EDT]**.
The background editing screen is displayed (PROGRAM (BG-EDIT) is displayed at the top left of the screen).
- 4 Edit a program on the background editing screen in the same way as for ordinary program editing.
- 5 After editing is completed, press soft key **[(OPRT)]**, then press soft key **[BG-EDT]**. The edited program is registered in foreground program memory.

Explanation

- **Alarms during background editing**

Alarms that may occur during background editing do not affect foreground operation. Conversely, alarms that may occur during foreground operation do not affect background editing. In background editing, if an attempt is made to edit a program selected for foreground operation, a BP/S alarm (No. 140) is raised. On the other hand, if an attempt is made to select a program subjected to background editing during foreground operation (by means of subprogram calling or program number search operation using an external signal), a P/S alarm (Nos. 059, 078) is raised in foreground operation. As with foreground program editing, P/S alarms occur in background editing. However, to distinguish these alarms from foreground alarms, BP/S is displayed in the data input line on the background editing screen.

9.9 PASSWORD FUNCTION

The password function (bit 4 (NE9) of parameter No. 3202) can be locked using parameter No. 3210 (PASSWD) and parameter No. 3211 (KEYWD) to protect program Nos. O9000 to O9999. In the locked state, parameter NE9 cannot be set to 0. In this state, program Nos. O9000 to O9999 cannot be modified unless the correct keyword is set.

A locked state means that the value set in the parameter PASSWD differs from the value set in the parameter KEYWD. The values set in these parameters are not displayed. The locked state is released when the value already set in the parameter PASSWD is also set in parameter KEYWD. When 0 is displayed in parameter PASSWD, parameter PASSWD is not set.

Procedure for locking and unlocking

Locking

- 1 Set the MDI mode.
- 2 Enable parameter writing. At this time, P/S alarm No. 100 is issued on the CNC.
- 3 Set parameter No. 3210 (PASSWD). At this time, the locked state is set.
- 4 Disable parameter writing.
- 5 Press the  key to release the alarm state.

Unlocking

- 1 Set the MDI mode.
- 2 Enable parameter writing. At this time, P/S alarm No. 100 is issued on the CNC.
- 3 In parameter No. 3211 (KEYWD), set the same value as set in parameter No. 3210 (PASSWD) for locking. At this time, the locked state is released.
- 4 Set bit 4 (NE9) of parameter No. 3202 to 0.
- 5 Disable parameter writing.
- 6 Press the  key to release the alarm state.
- 7 Subprograms from program Nos. 9000 to 9999 can now be edited.

Explanations

- **Setting parameter PASSWD**

The locked state is set when a value is set in the parameter PASSWD. However, note that parameter PASSWD can be set only when the locked state is not set (when PASSWD = 0, or PASSWD = KEYWD). If an attempt is made to set parameter PASSWD in other cases, a warning is given to indicate that writing is disabled. When the locked state is set (when PASSWD = 0 and PASSWD = KEYWD), parameter NE9 is automatically set to 1. If an attempt is made to set NE9 to 0, a warning is given to indicate that writing is disabled.

- **Changing parameter PASSWD**

Parameter PASSWD can be changed when the locked state is released (when PASSWD = 0, or PASSWD = KEYWD). After step 3 in the procedure for unlocking, a new value can be set in the parameter PASSWD. From that time on, this new value must be set in parameter KEYWD to release the locked state.

- **Setting 0 in parameter PASSWD**

When 0 is set in the parameter PASSWD, the number 0 is displayed, and the password function is disabled. In other words, the password function can be disabled by either not setting parameter PASSWD at all, or by setting 0 in parameter PASSWD after step 3 of the procedure for unlocking. To ensure that the locked state is not entered, care must be taken not to set a value other than 0 in parameter PASSWD.

- **Re-locking**

After the locked state has been released, it can be set again by setting a different value in parameter PASSWD, or by turning the power to the NC off then on again to reset parameter KEYWD.

CAUTION

Once the locked state is set, parameter NE9 cannot be set to 0 and parameter PASSWD cannot be changed until the locked state is released or the memory all-clear operation is performed. Special care must be taken in setting parameter PASSWD.

9.10 COPYING A PROGRAM BETWEEN TWO PATHS

For a 2-path control CNC, setting bit 0 (PCP) of parameter No. 3206 to 1 enables the copying of a specified machining program from one path to another. Single-program copy and specified-range copy are supported.

Procedure for copying a program between two paths

Procedure

- 1 Select EDIT mode for both paths.
- 2 Press function key  .
- 3 Press soft key **[(OPRT)]**.
- 4 Press soft key **[P COPY]**
The following soft keys appear:

```

PROGRAM                                O1357      N00130
O1357 (HEAD-1 MAIN PROGRAM);
N010  G90 G00 X200.0 Z220.0 ;
N020  T0101;
N030  S30000 M03 ;
N040  G40 G00 X40.0 Z180.0 ;

~

N080  X100.0 Z80.0 ;
N090  Z60.0 ;
N100  X140.0 Z40.0 ;

>_

EDIT **** * 14:25:36 HEAD1
{ PATH1 } {           } { PATH2 } {           } { CAN }

```

- 5 Press soft key **[PATH1]** to **[PATH2]** to select the path from which a program is to be copied.

(Example) Pressing soft key **[PATH1]** causes an operation guidance, shown below, to appear on the screen.

```

SOURCE : PATH1 =1357
DEST : PATH2  =      REPLACE : OFF
>_

EDIT **** * 14:25:36 HEAD1
{ SOURCE } { DEST } { REPLACE } { CAN } { EXEC }

```

First, the program currently selected for the copy source path is displayed as the program to be copied. If no program has been selected for the copy source path, "0000" is displayed.

6 Select one or more programs to be copied.

- Single-program copy

(1) Enter the number of the program to be copied. → “× × × ×”

(2) Press soft key **[SOURCE]** to set the number.

→ SOURCE:PATH?“× × × ×”

- Specified-range copy

(1) Enter the range of the programs to be copied, as a number.

→ “× × × ×-□□□□”

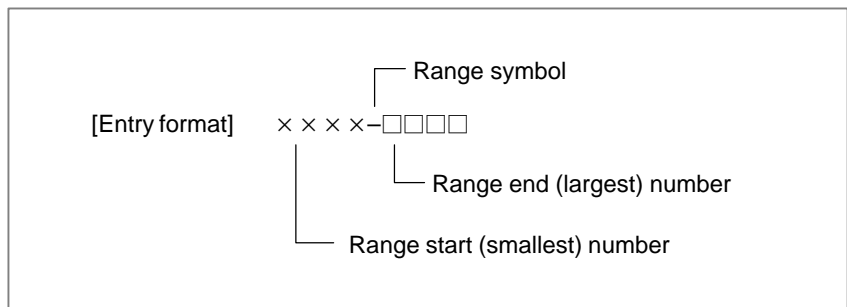

(2) Press soft key **[SOURCE]** to set the number.

→ “× × × ×-□□□□”

- To cancel the selection of the program(s) to be copied, press **[SOURCE]** again

7 Select the copy destination number.

The selected program(s) can be copied by assigning numbers other than their original numbers.

(1) Type the destination number. → “△△△△”

(2) Press soft key **[DEST]** to set the number.

→ DEST:PATH?“△△△△”

- Pressing **[DEST]** without entering any number causes the original program number(s) to be used as is.
- To cancel the set number, press **[DEST]** again.
- For specified-range copy, the set number is assigned to the first program of the specified range. The subsequent programs are assigned numbers obtained by repeatedly incrementing the set number by one.

8 Specify replacement.

If any number to be assigned to a program to be copied is already being used for a program registered for the destination path, specify whether the existing program is to be replaced with that to be copied. If replacement is currently disabled, pressing soft key **[REPLACE]** enables replacement. Pressing **[REPLACE]** repeatedly toggles between replacement being enabled and disabled.

“REPLACE=ON” indicates that replacement is enabled.

“REPLACE=OFF” indicates that replacement is disabled.

9 Press soft key **[EXEC]** to start copying.

Explanations

● **Operation flow**

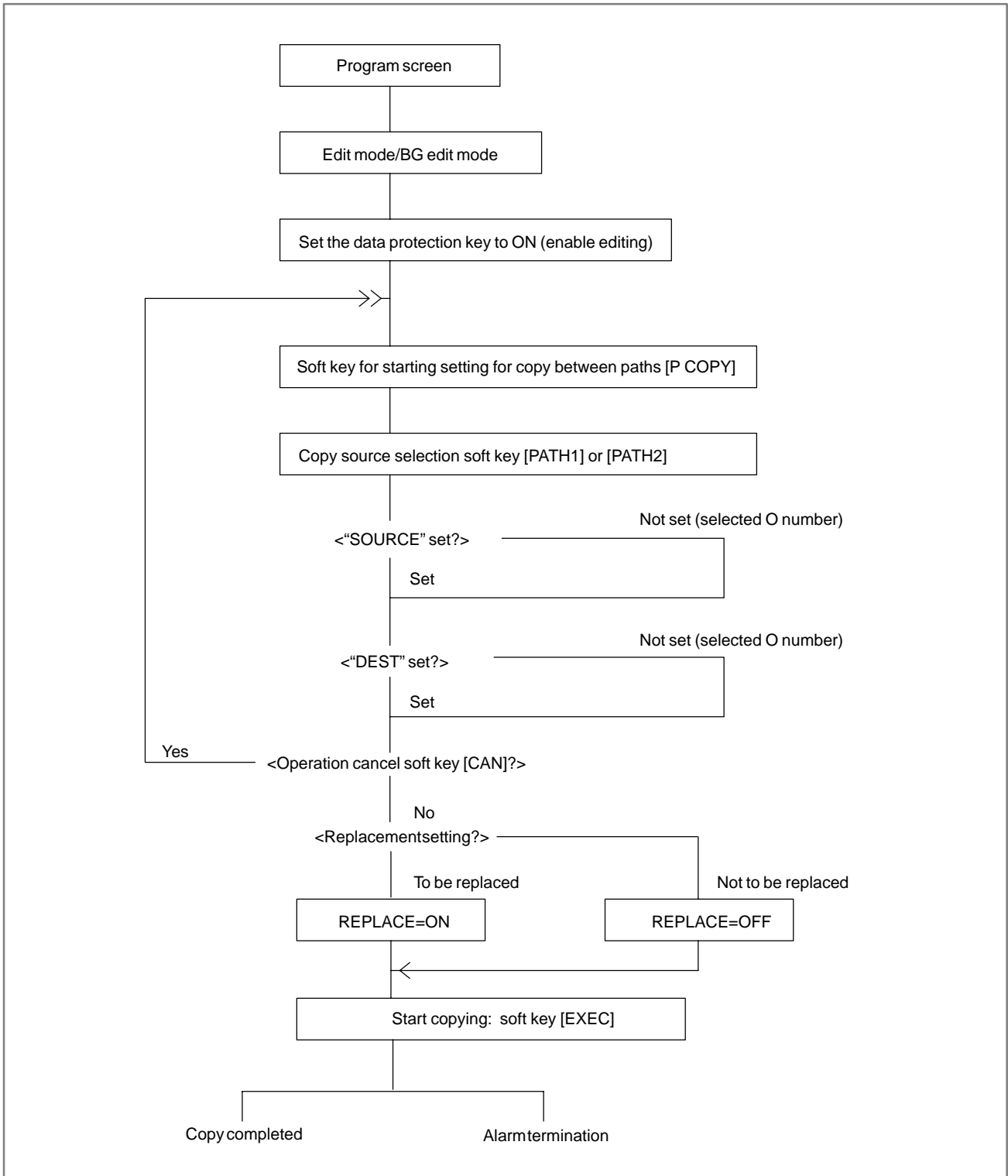

● **Background editing**

Copying can also be performed during background editing.

● Major related alarms

Major related alarm numbers

Alarm number	Description	Relevant path
P/S 70,70 BP/S0	Insufficient free memory	Copy destination
P/S 71,71 BP/S	Specified program not found	Copy source
P/S 72,72 BPS	Too many programs	Copy destination
P/S 73,73 BP/S	Duplicate registration	Copy destination
P/S 75,75 BP/S	Protected program number	Copy source/destination

- BP/S indicates an alarm output during background editing.
- Each alarm is issued to the path for which the operation causing the alarm is being performed.

Restrictions

● Conditions under which copying cannot be performed

Copying is not performed under any of the following conditions:

- The data protection key for the copy destination path is set to OFF.
- The specified O number is protected.
- The specified O number is already being used for a program registered for the copy destination path (if replacement is disabled).
- The part program storage for the copy destination path does not have sufficient free space.
- The copy source or destination path is placed in the alarm state. During background editing, however, only P/S alarms 000 and 101 disable copying.

● Specified-range copy

During specified-range copy, if the part program storage for the copy destination path becomes insufficient, if the maximum number of programs which can be registered for the destination path is exceeded, if a specified program number has already been registered for the destination path, or if a specified program number is protected, an alarm is issued immediately and copying is stopped.

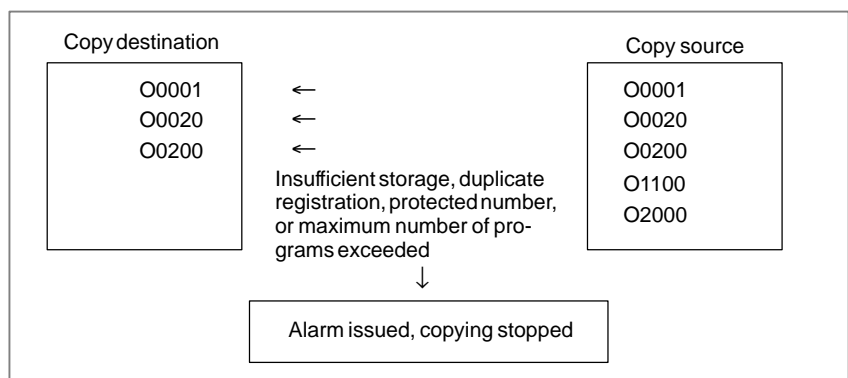

● Replacement

Even if replacement is enabled, the program is not replaced if the part program storage for the copy destination path does not have sufficient free space. During background editing, copying by replacing the currently running program is not allowed.

CAUTION

Once the copying of a program between paths has been started, it cannot be canceled. Carefully confirm all the settings before starting copying.

10 CREATING PROGRAMS



Programs can be created using any of the following methods:

- MDI keyboard
- PROGRAMMING IN TEACH IN MODE
- CONVERSATIONAL PROGRAMMING INPUT WITH GRAPHIC FUNCTION
- CONVERSATIONAL AUTOMATIC PROGRAMMING FUNCTION
- AUTOMATIC PROGRAM PREPARATION DEVICE (FANUC SYSTEM P)



This chapter describes creating programs using the MDI panel, TEACH IN mode, and conversational programming with graphic function. This chapter also describes the automatic insertion of sequence numbers.

10.1 CREATING PROGRAMS USING THE MDI PANEL

Programs can be created in the **EDIT** mode using the program editing functions described in Chapter III-9.

Procedure for Creating Programs Using the MDI Panel

Procedure



- 1 Enter the **EDIT** mode.
- 2 Press the  key.
- 3 Press address key  and enter the program number.
- 4 Press the  key.
- 5 Create a program using the program editing functions described in Chapter 9.

Explanation

• Comments in a program

Comments can be written in a program using the control in/out codes.

Example)O0001 (FANUC SERIES 16) ;
M08 (COOLANT ON) ;

- When the  key is pressed after the control-out code “(”, comments, and control-in code “)” have been typed, the typed comments are registered.
- When the  key is pressed midway through comments, to enter the rest of comments later, the data typed before the  key is pressed may not be correctly registered (not entered, modified, or lost) because the data is subject to an entry check which is performed in normal editing.

Note the following to enter a comment:





- Control-in code “)” cannot be registered by itself.
- Comments entered after the  key is pressed must not begin with a number, space, or address O.
- If an abbreviation for a macro is entered, the abbreviation is converted into a macro word and registered (see Section 9.7).
- Address O and subsequent numbers, or a space can be entered but are omitted when registered.

10.2 AUTOMATIC INSERTION OF SEQUENCE NUMBERS

Sequence numbers can be automatically inserted in each block when a program is created using the MDI keys in the EDIT mode.
Set the increment for sequence numbers in parameter 3216.

Procedure for automatic insertion of sequence numbers

Procedure

- 1 Set 1 for SEQUENCE NO. (see subsection III-11.4.3).
- 2 Enter the **EDIT** mode.
- 3 Press  to display the program screen.
- 4 Search for or register the number of a program to be edited and move the cursor to the EOB (;) of the block after which automatic insertion of sequence numbers is started.
When a program number is registered and an EOB (;) is entered with the  key, sequence numbers are automatically inserted starting with 0. Change the initial value, if required, according to step 10, then skip to step 7.
- 5 Press address key  and enter the initial value of N.
- 6 Press  key.
- 7 Enter each word of a block.
- 8 Press  key.

- 9 Press . The EOB is registered in memory and sequence numbers are automatically inserted. For example, if the initial value of N is 10 and the parameter for the increment is set to 2, N12 inserted and displayed below the line where a new block is specified.



```

PROGRAM                                O0040 N00012
O0040 ;
N10 G92 X0 Y0 Z0 ;
N12
%

>_
EDIT **** * * * * *                13 : 18 : 08
( PRGRM ) ( LIB ) (          ) ( C.A.P ) ( (OPRT) )

```

10

- In the example above, if N12 is not necessary in the next block, pressing the  key after N12 is displayed deletes N12.
- To insert N100 in the next block instead of N12, enter N100 and press  after N12 is displayed. N100 is registered and initial value is changed to 100.

10.3 CREATING PROGRAMS IN TEACH IN MODE (PLAYBACK)

When the playback option is selected, the **TEACH IN JOG** mode and **TEACH IN HANDLE** mode are added. In these modes, a machine position along the X, Z, and Y axes obtained by manual operation is stored in memory as a program position to create a program.

The words other than X, Z, and Y, which include O, N, G, R, F, C, M, S, T, P, Q, and EOB, can be stored in memory in the same way as in **EDIT** mode.

Procedure for Creating Programs in TEACH IN Mode

The procedure described below can be used to store a machine position along the X, Z, and Y axes.

- 1 Select the **TEACH IN JOG** mode or **TEACH IN HANDLE** mode.
- 2 Move the tool to the desired position with jog or handle.
- 3 Press key to display the program screen. Search for or register the number of a program to be edited and move the cursor to the position where the machine position along each axis is to be registered (inserted).
- 4 Key in address .
- 5 Press the key. Then a machine position along the X axis is stored in memory.
(Example) X10.521 Absolute position (for mm input)
X10521 Data stored in memory
- 6 Similarly, key in , then press the key. Then a machine position along the Z axis is stored in memory. Further, key in , then press the key. Then a machine position along the Y axis is stored in memory.

All coordinates stored using this method are absolute coordinates.

Examples

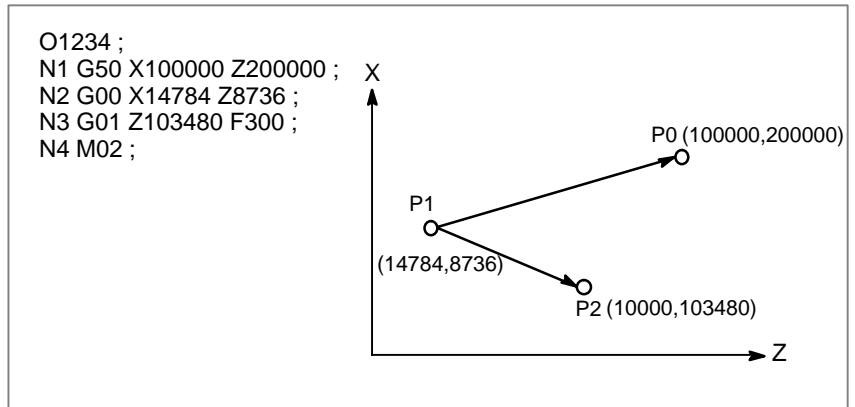

- 1 Set the setting data **SEQUENCE NO.** to 1 (on). (The incremental value parameter (No. 3212) is assumed to be "1".)
- 2 Select the **TEACH IN HANDLE** mode.
- 3 Make positioning at position P0 by the manual pulse generator.
- 4 Select the program screen.

- 5 Enter program number O1234 as follows:

This operation registers program number O1234 in memory.

Next, press the following keys:

An EOB (;) is entered after program number O1234. Because no number is specified after N, sequence numbers are automatically inserted for N0 and the first block (N1) is registered in memory.

- 6 Enter the P0 machine position for data of the first block as follows:

This operation registers G50 X100000 Z200000 ; in memory. The automatic sequence number insertion function registers N2 of the second block in memory.

- 7 Position the tool at P1 with the manual pulse generator.

- 8 Enter the P1 machine position for data of the second block as follows:

This operation registers G00 X14784 Z8736; in memory. The automatic sequence number insertion function registers N3 of the third block in memory.

- 9 Position the tool at P2 with the manual pulse generator.

10 Enter the P2 machine position for data of the third block as follows:

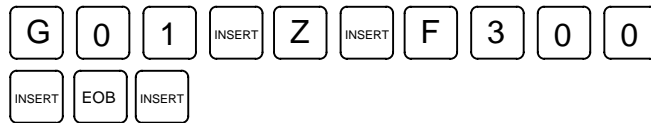

This operation registers G01 Z103480 F300; in memory.
The automatic sequence number insertion function registers N4 of the fourth block in memory.

11 Register M02; in memory as follows:



N5 indicating the fifth block is stored in memory using the automatic sequence number insertion function. Press the key to delete it.

This completes the registration of the sample program.

Explanations

- **Checking contents of the memory**

The contents of memory can be checked in the **TEACH IN** mode by using the same procedure as in **EDIT** mode.

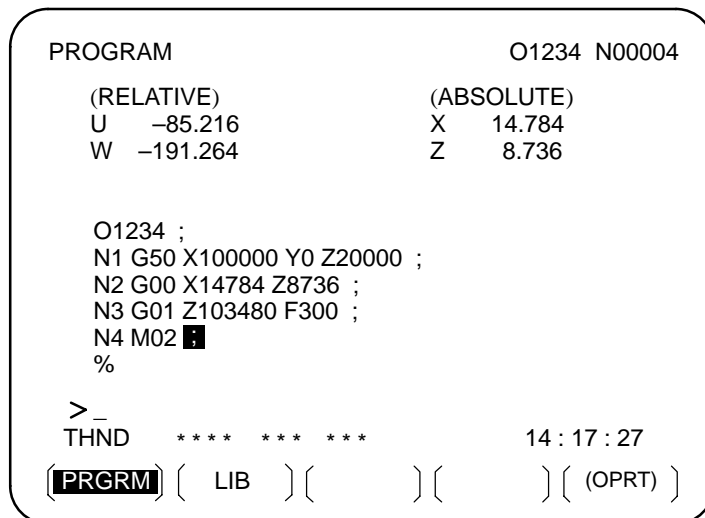

- **Registering a position with compensation**

When a value is keyed in after keying in address , , or , then the key is pressed, the value keyed in for a machine position is added for registration. This operation is useful to correct a machine position by key-in operation.

- **Registering commands other than position commands**

Commands to be entered before and after a machine position must be entered before and after the machine position is registered, by using the same operation as program editing in **EDIT** mode.

10.4 CONVERSATIONAL PROGRAMMING WITH GRAPHIC FUNCTION

Programs can be created block after block on the conversational screen while displaying the G code menu.

Blocks in a program can be modified, inserted, or deleted using the G code menu and conversational screen.

Procedure for Conversational Programming with Graphic Function

Procedure 1 Creating a program

- 1 Enter the **EDIT** mode.
- 2 Press . If no program is registered, the following screen is displayed. If a program is registered, the program currently selected is displayed.

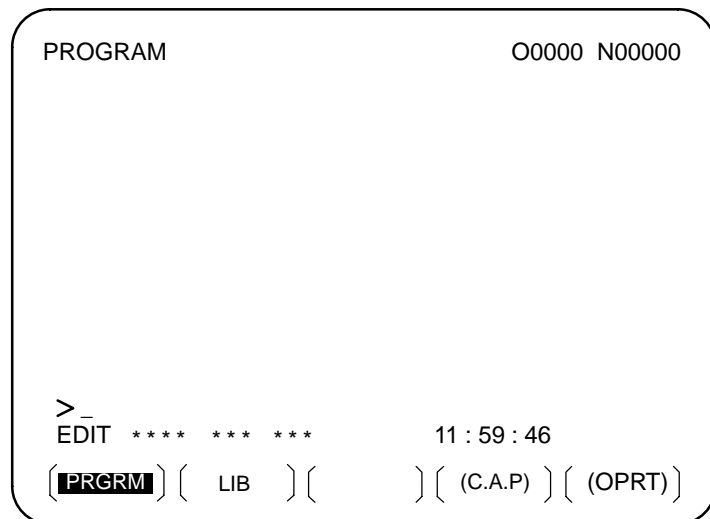

- 3 Key in the program number of a program to be registered after keying in address O, then press . For example, when a program with program number 10 is to be registered, key in , then press . This registers a new program O0010.

- 4 Press the **[C.A.P]** soft key. The following G code menu is displayed on the screen.

If soft keys different from those shown in step 2 are displayed, press the menu return key  to display the correct soft keys.

```

PROGRAM                                O1234 N00004
G00 : POSITIONING
G01 : LINEAR IPL
G02 : CIRCULAR IPL. CW
G03 : CIRCULAR IPL. CCW
G04 : DWELL
G10 : OFFSET VALUE SETTING            (0)
G20 : INCH
G21 : METRIC
G22 : STORED STROKE CHECK ON          (0)
G23 : STORED STROKE CHECK OFF         (0)
G25 : SPINDLE SPEED DETECT OFF
G26 : SPINDLE SPEED DETECT ON
>_
EDIT **** * * * *                    14 : 26 : 15
{ PRGRM } {          } { G.MENU } { BLOCK } {          }

```

- 5 Key in the G code corresponding to a function to be programmed. When the positioning function is desired, for example, the G code menu lists the function with the G code G00. So key in G00. If the screen does not indicate a function to be programmed, press the page key  to display the next G code menu screen. Repeat this operation until a desired function appears. If a desired function is not a G code, key in no data.
- 6 Press the soft key **[BLOCK]** to display a detailed screen for a keyed in G code. The figure below shows an example of detailed screen for G00.

```

PROGRAM                                O1234 N00000
G00 : POSITIONING

G00  G      G  G  X
X   [REDACTED] U
Z           W          (X, Z)
M
S
T
:                               U
                                   W  Z

EDIT **** * * * *                    14 : 32 : 57
{ PRGRM } {          } { G.MENU } { BLOCK } { (OPRT) }





```

When no keys are pressed, the standard details screen is displayed.

PROGRAM		O0010 N00000	
G	█	G	G
X		U	
Z		W	
A		C	
F		H	
I		K	
P		Q	
R		M	
S		T	
:			
EDIT **** * * *		14 : 41 : 10	
{ PRGRM }	{	{ G.MENU }	{ BLOCK }
{	}	{	{ OPRT }

- 7 Move the cursor to the block to be modified on the program screen. At this time, a data address with the cursor blinks.
- 8 Enter numeric data by pressing the numeric keys and press the **[INPUT]** soft key or key. This completes the input of one data item.
- 9 Repeat this operation until all data required for the entered G code is entered.
- 10 Press the key. This completes the registration of data of one block in program memory. On the screen, the G code menu screen is displayed, allowing the user to enter data for another block. Repeat the procedure starting with 5 as required.
- 11 After registering all programs, press the **[PRGRM]** soft key. The registered programs are converted to the conversational format and displayed.
- 12 Press the key to return to the program head.

Procedure 2 Modifying a block

- 1 Move the cursor to the block to be modified on the program screen and press the **[C.A.P]** soft key. Or, press the **[C.A.P]** soft key first to display the conversational screen, then press the  or  page key until the block to be modified is displayed.
- 2 When data other than a G code is to be altered, just move the cursor to the data and key in a desired value, then press the **[INPUT]** soft key or  key.
- 3 When a G code is to be altered, press the menu return key  and the soft key **[G.MENU]**. Then the G code menu appears. Select a desired G code, then key in the value. For example, to specify a cutting feed, since the G code menu indicates G01, key in G01. Then press the soft key **[BLOCK]**. The detailed screen of the G code is displayed, so enter the data.
- 4 After data is changed completely, press the  key. This operation replaces an entire block of a program.

Procedure 3 Inserting a block

- 1 On the conversational screen, display the block immediately before a new block is to be inserted, by using the page keys. On the program screen, move the cursor with the page keys and cursor keys to immediately before the point where a new block is to be inserted.
- 2 Press the soft key **[G.MENU]** to display the G code menu. Then enter new block data.
- 3 When input of one block of data is completed in step 2, press the  key. This operation inserts a block of data.

Procedure 4 Deleting a block

- 1 On the conversational screen, display the contents of a block to be deleted, then press the  key.
- 2 The contents of the block displayed are deleted from program memory. Then the contents of the next block are displayed on the conversational screen.

11

SETTING AND DISPLAYING DATA

General

To operate a CNC machine tool, various data must be set on the CRT/MDI or LCD/MDI for the CNC. The operator can monitor the state of operation with data displayed during operation.

This chapter describes how to display and set data for each function.



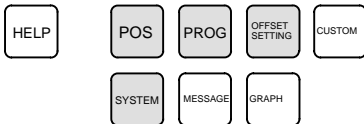

Explanations

• Screen transition chart



MDI function keys
(Shaded keys () are described
in this chapter.)

The screen transition for when each function key on the MDI panel is pressed is shown below. The subsections referenced for each screen are also shown. See the appropriate subsection for details of each screen and the setting procedure on the screen. See other chapters for screens not described in this chapter.

See Chapter III-7 for the screen that appears when function key  is pressed. See Chapter III-12 for the screen that appears when function key  is pressed. See Chapter III-13 for the screen that appears when function key  is pressed. In general, function key  is prepared by the machine tool builder and used for macros. Refer to the manual issued by the machine tool builder for the screen that appears when function key  is pressed.

• Data protection key

The machine may have a data protection key to protect part programs, tool compensation values, setting data, and custom macro variables. Refer to the manual issued by the machine tool builder for where the data protection key is located and how to use it.

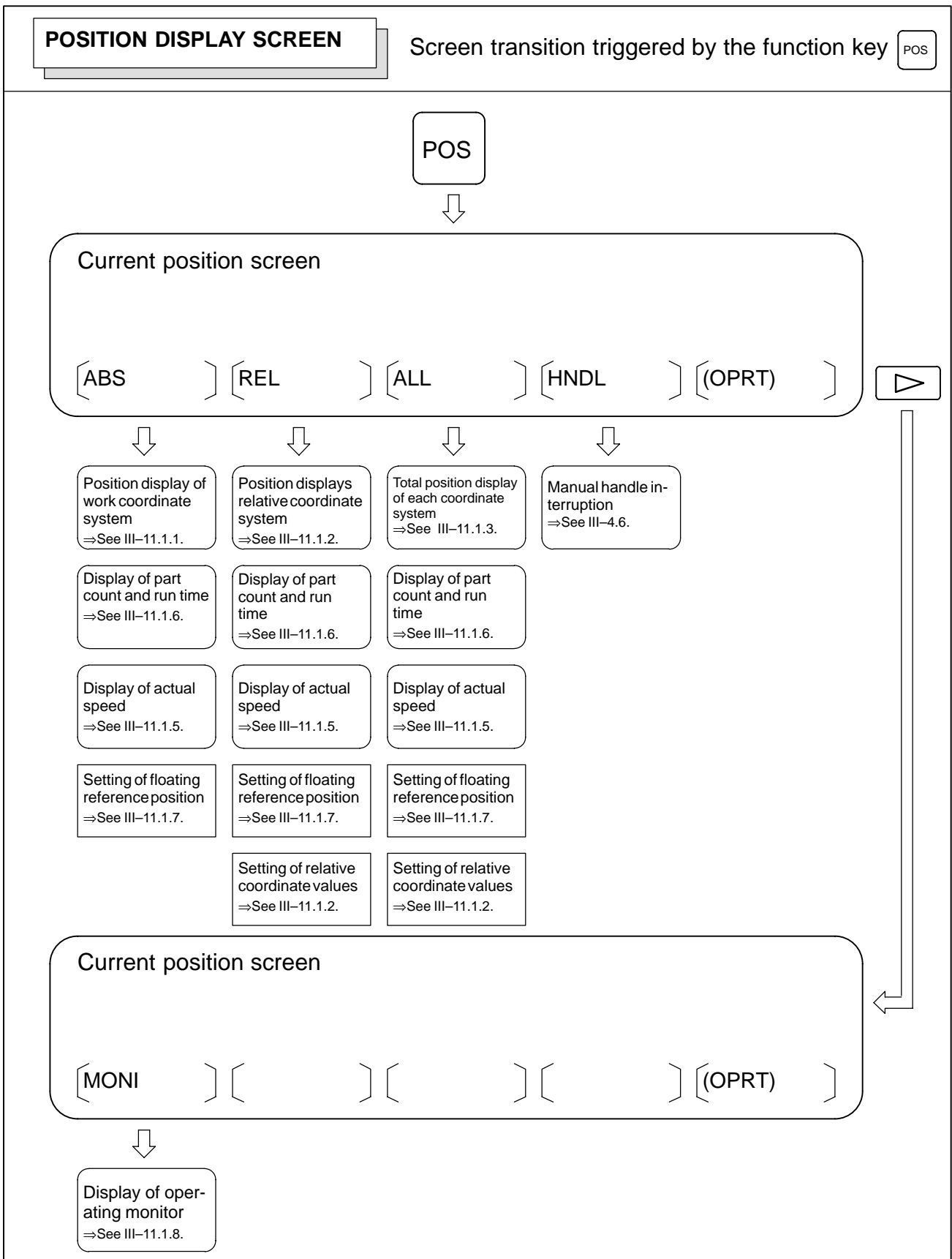

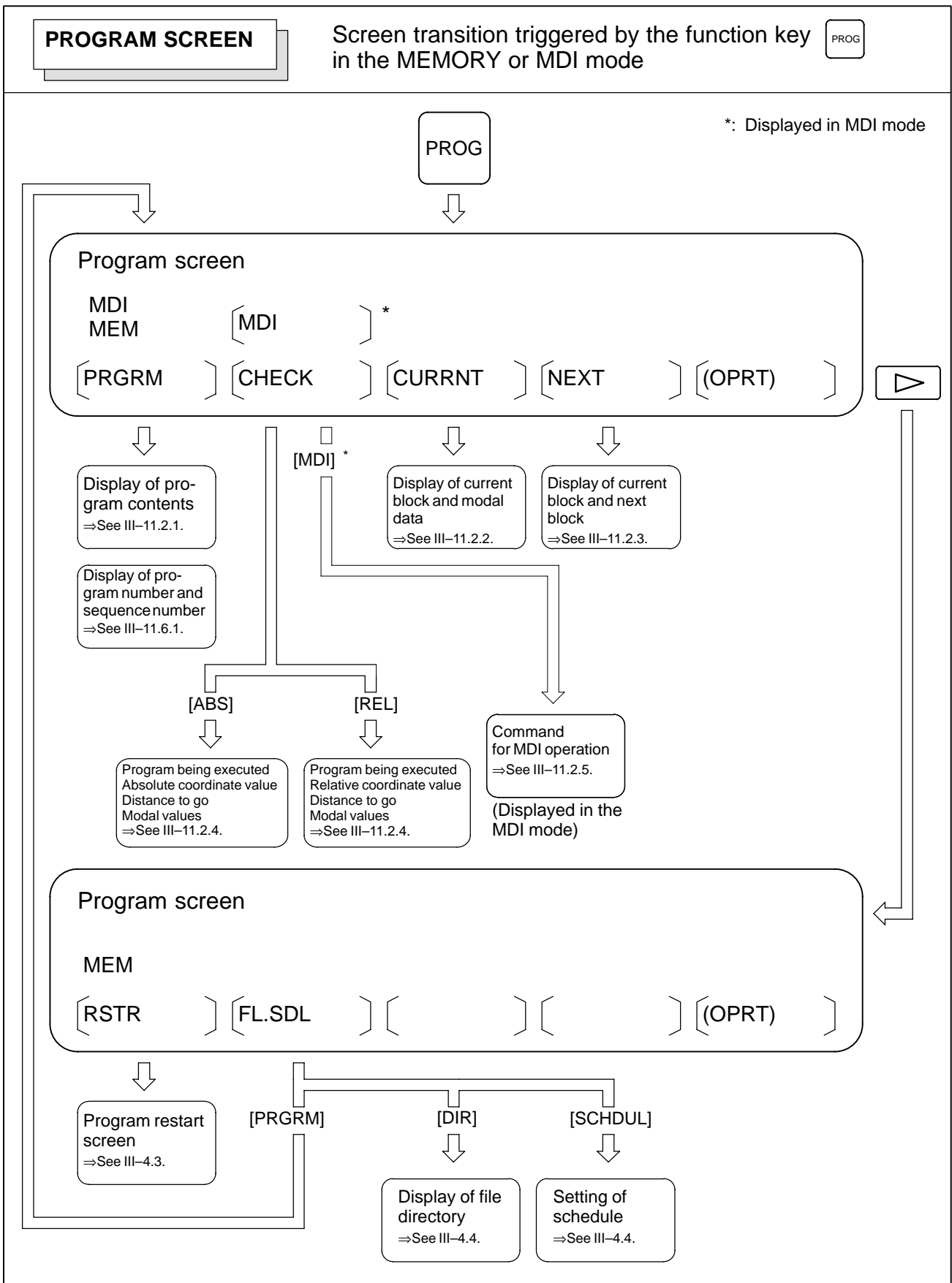

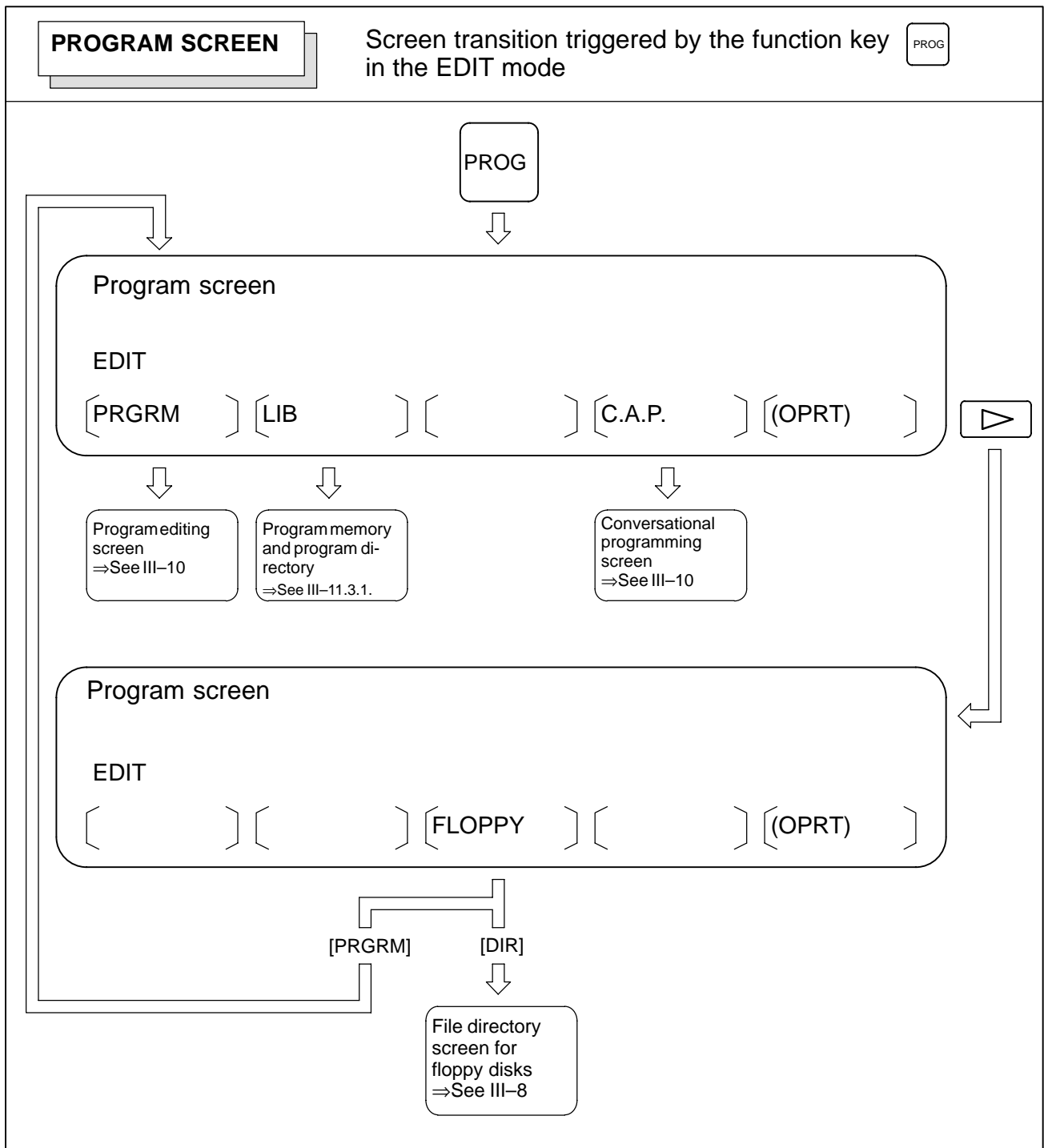

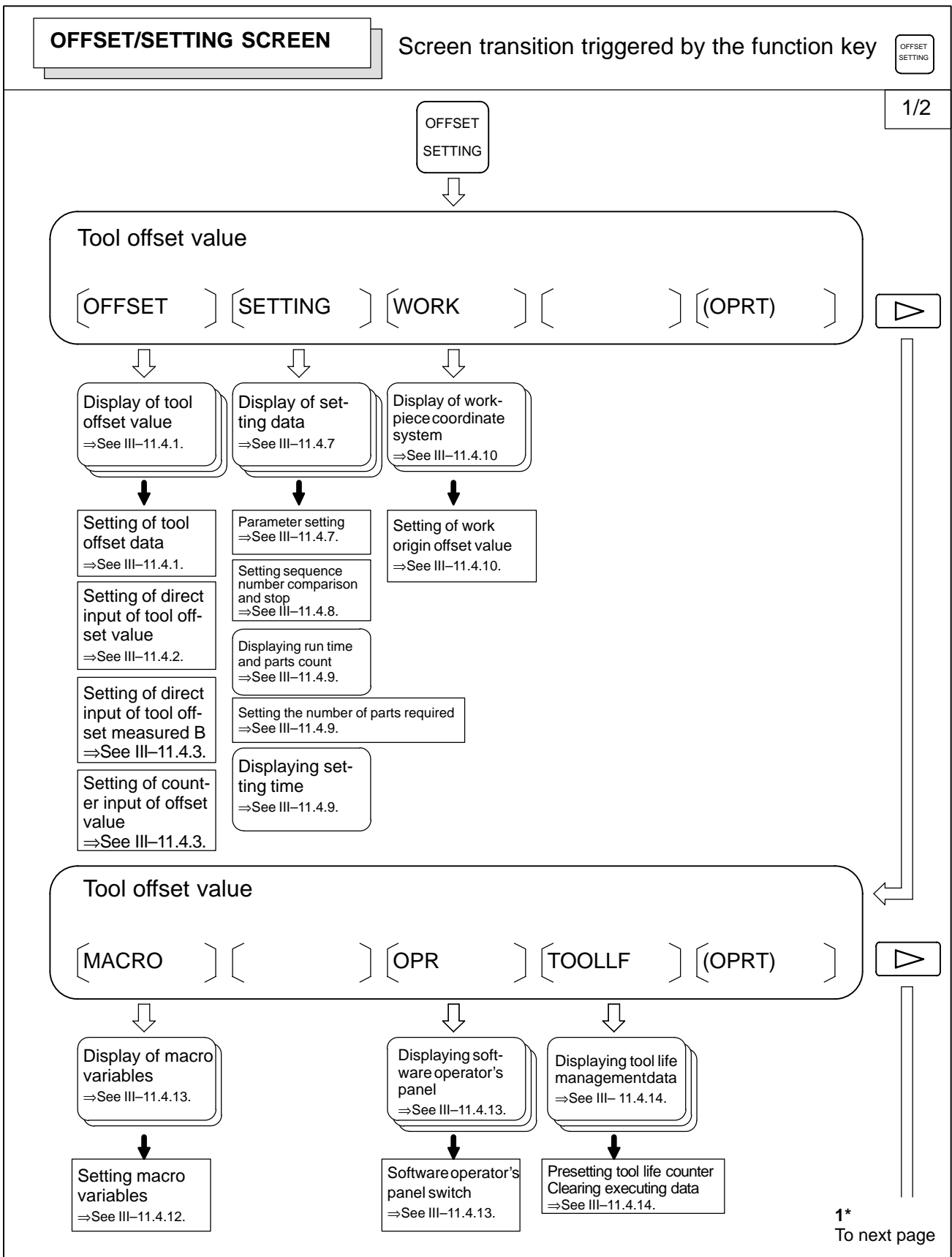

1*

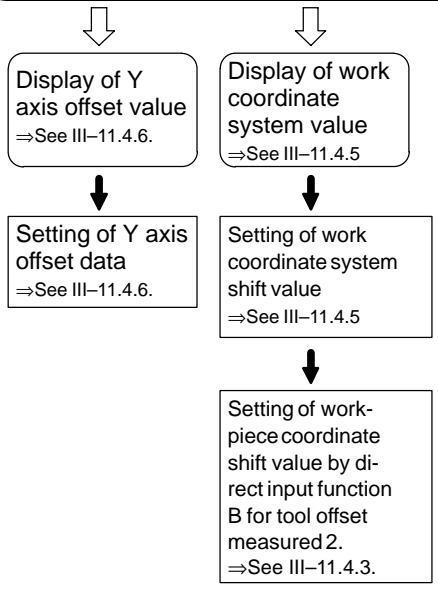
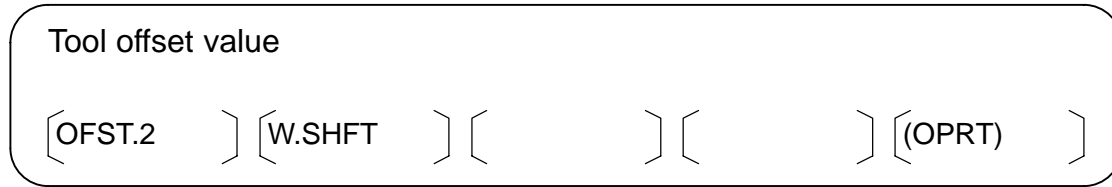

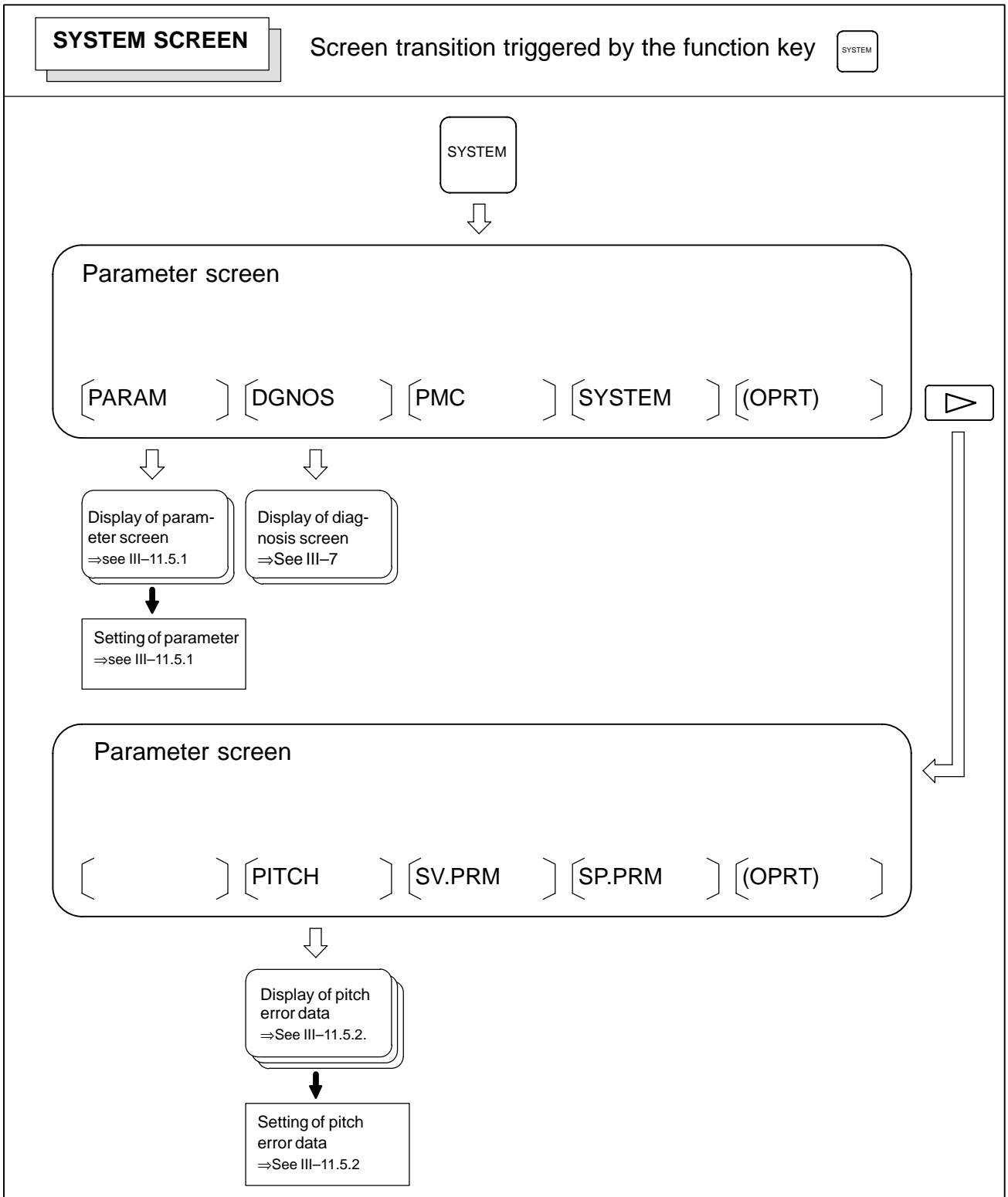

- **Setting screens**

The table below lists the data set on each screen.

Table 11. Setting screens and data on them

No.	Setting screen	Contents of setting	Reference item
1	Tool offset value	Tool offset value Tool nose radius compensation value	Subsec. III-11.4.1
		Direct input of tool offset value	Subsec. III-11.4.2
		Direct input of tool offset value measured B	Subsec. III-11.4.3
		Counter input of offset value	Subsec. III-11.4.4
		Y axis offset	Subsec. III-11.4.6
2	Workpiece coordinate system setting	Workpiece coordinate system shift value	Subsec. III-11.4.5
		Workpiece origin offset value	Subsec. III-11.4.10
3	Setting data (handy)	Parameter write TV check Punch code (EIA/ISO) Input unit (mm/inch) I/O channel Automatic insert of Sequence No. Conversion of tape format (F15)	Subsec. III-11.4.7
		Sequence number comparison and stop	Subsec. III-11.4.8
4	Setting data (mirror image)	Mirror image	Subsec. III-11.4.7
5	Setting data (timer)	Parts required	Subsec. III-11.4.9
6	Macro variables	Custom macro common variables (#100 to #149) or (#100 to #199) (#500 to #531) or (#500 to #599)	Subsec. III-11.4.12
7	Parameter	Parameter	Subsec. III-11.5.1
8	Pitch error	Pitch error compensation data	Subsec. III-11.5.2
9	software operator's panel	Mode selection Jog feed axis selection Jog rapid traverse Axis selection for Manual pulse generator Multiplication for manual pulse generator Jog feedrate Feedrate override Rapid traverse override Optional block skip Single block Machine lock Dry run Protect key Feed hold	Subsec. III-11.4.13
10	Tool life data (Tool life management)	Life count	Subsec. III-11.4.14
11	Current position display screen	Floating reference position	Subsec. III-11.1.7

11.1 SCREENS DISPLAYED BY FUNCTION KEY

Press function key  to display the current position of the tool.

The following three screens are used to display the current position of the tool:

- **Position display screen for the work coordinate system.**
- **Position display screen for the relative coordinate system.**
- **Overall position display screen.**

The above screens can also display the feedrate, run time, and the number of parts. In addition, a floating reference position can be set on these screens.

Function key  can also be used to display the load on the servo motor and spindle motor and the rotation speed of the spindle motor (operating monitor display).

Function key  can also be used to display the screen for displaying the distance moved by handle interruption. See Section 4.6 for details on this screen.

11.1.1 Position Display in the Workpiece Coordinate System

Displays the current position of the tool in the workpiece coordinate system. The current position changes as the tool moves. The least input increment is used as the unit for numeric values. The title at the top of the screen indicates that absolute coordinates are used.

Display procedure for the current position screen in the workpiece coordinate system

- 1 Press function key  .
- 2 Press soft key **[ABS]**.
- 3 On (7 soft keys display unit), press the **[ABS]** soft key one more time to display the coordinates along axes other than the six standard axes.

- Display with one-path control

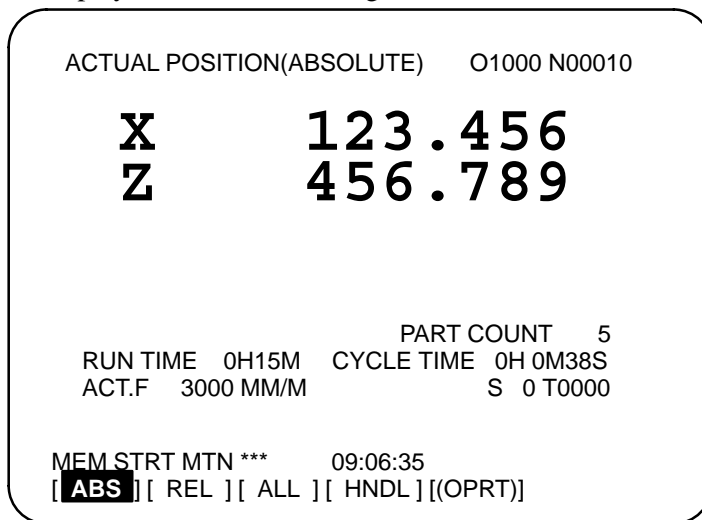

- Display with two-path control
(7 soft keys display unit)

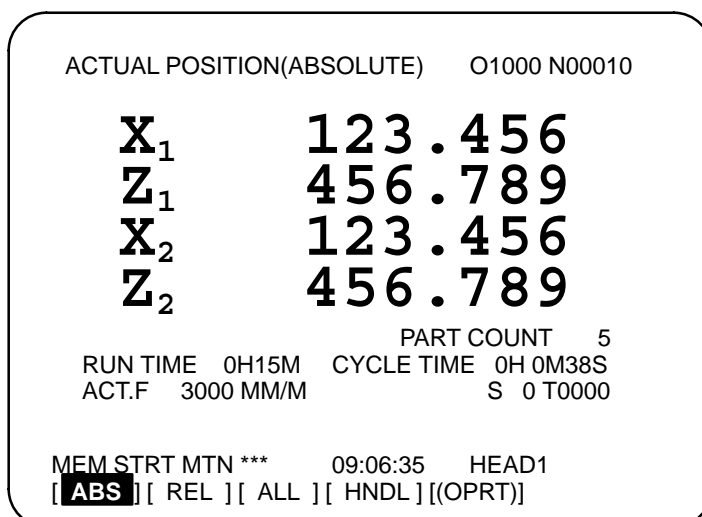

NOTE

For the two-path control, the display may not be as shown above. In some cases, only the coordinates along the axes on tool post 1 are displayed due to the number of axes. In that case, press the **[ABS]** soft key one more time to display the coordinates along the axes on tool post 2.

● **Display with two-path control (12 soft keys display unit)**

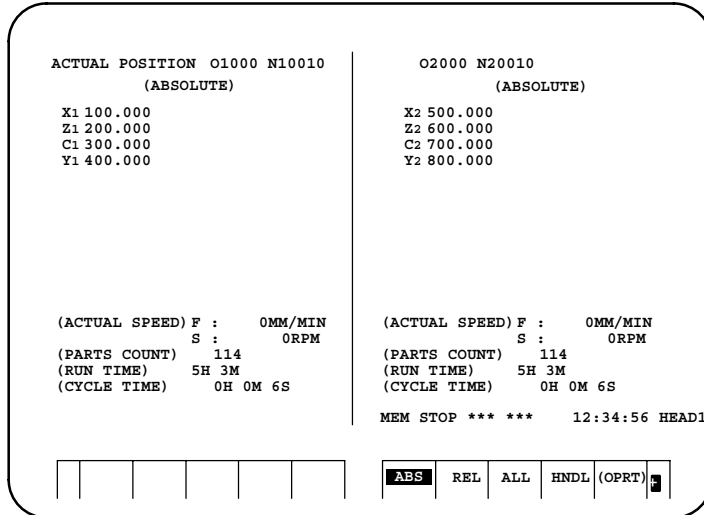

Explanations

- **Display including compensation values**
- **Displaying the sixth and subsequent axes**

Bits 6 and 7 of parameter 3104 can be used to select whether the displayed values include tool offset value and tool nose radius compensation.

On 7 soft keys display unit or the shared screen of 12 soft keys display unit, only the coordinates for the first to fifth axes are displayed initially whenever there are six or more controlled axes. Pressing the **[ABS]** soft key displays the coordinates for the sixth and subsequent axes. When six or more controlled axes are used under two-path control, the coordinates for path 1 are displayed initially on 7 soft keys display unit. Pressing the **[ABS]** soft key displays the coordinates for path 2. On the shared screen of 12 soft keys display unit, the tool post selection signal is used to select the display for path 1 or 2.

11.1.2 Position Display in the Relative Coordinate System

Displays the current position of the tool in a relative coordinate system based on the coordinates set by the operator. The current position changes as the tool moves. The increment system is used as the unit for numeric values. The title at the top of the screen indicates that relative coordinates are used.

Display procedure for the current position screen with the relative coordinate system

- 1 Press function key  .
- 2 Press soft key [REL].
- 3 On 7 soft key display unit, press the [REL] soft key one more time to display the coordinates along axes other than the six standard axes.

• Display with one-path control

ACTUAL POSITION(RELATIVE)		O1000 N00010
U	123.456	
W	456.789	
PART COUNT		5
RUN TIME	0H15M	CYCLE TIME 0H 0M38S
ACT.F	3000 MM/M	S 0 T0000
MEM STRT MTN ***	09:06:35	
[ABS]	[REL]	[ALL] [HNDL] [(OPRT)]

• Display with two-path control (7 soft keys display unit)

ACTUAL POSITION(RELATIVE)		O1000 N00010
U₁	100.000	
W₁	200.000	
U₂	300.000	
W₂	400.000	
PART COUNT		5
RUN TIME	0H15M	CYCLE TIME 0H 0M38S
ACT.F	3000 MM/M	S 0 T0000
MEM STRT MTN ***	09:06:35	HEAD1
[ABS]	[REL]	[ALL] [HNDL] [(OPRT)]

NOTE

For the two-path lathe control 7 soft keys display unit, the display may not be as shown above. In some cases, only the coordinates along the axes on tool post 1 are displayed due to the number of axes. In that case, press the **[REL]** soft key one more time to display the coordinates along the axes on tool post 2.

● **Display with two-path control (12 soft keys display unit)**

ACTUAL POSITION O1000 N10010 (RELATIVE) U1 100.000 W1 200.000 H1 300.000 V1 400.000	O2000 N20010 (RELATIVE) U2 500.000 W2 600.000 A2 700.000 B2 800.000
(ACTUAL SPEED) F : OMM/MIN S : ORPM (PARTS COUNT) 114 (RUN TIME) 5H 3M (CYCLE TIME) 0H 0M 6S	(ACTUAL SPEED) F : OMM/MIN S : ORPM (PARTS COUNT) 114 (RUN TIME) 5H 3M (CYCLE TIME) 0H 0M 6S
MEM STOP *** ** 12:34:56 HEAD1	
ABS REL ALL HNDL (OPRT)	

Explanations

- **Setting the relative coordinates**

The current position of the tool in the relative coordinate system can be reset to 0 or preset to a specified value as follows:

Procedure to set the axis coordinate to a specified value

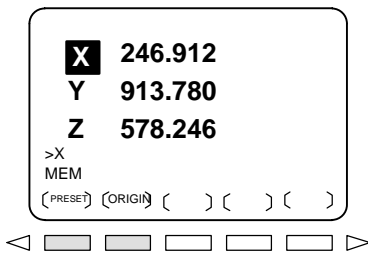

- 1 Enter an axis address (such as X or Z) on the screen for the relative coordinates. The indication for the specified axis blinks and the soft keys change as shown on the left.
- 2
 - To reset the coordinate to 0, press soft key **[ORIGIN]**. The relative coordinate for the blinking axis is reset to 0.
 - To preset the coordinate to a specified value, enter the value and press soft key **[PRESET]**. The relative coordinate for the blinking axis is set to the entered value.

Procedure to reset all axes

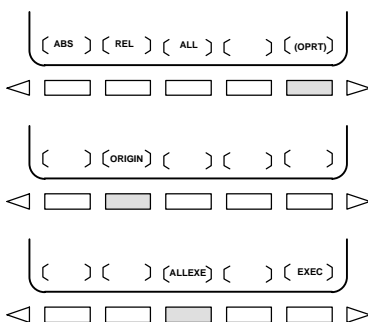

- 1 Press soft key **[OPRT]**.
- 2 Press soft key **[ORIGIN]**.
- 3 Press soft key **[ALLEXE]**.
The relative coordinates for all axes are reset to 0.

- **Display including compensation values**

Bits 4 (DRL) and 5 (DRC) of parameter 3104 can be used to select whether the displayed values include tool offset and tool nose radius compensation.

- **Presetting by setting a coordinate system**

Bit 3 of parameter 3104 is used to specify whether the displayed positions in the relative coordinate system are preset to the same values as in the workpiece coordinate system when a coordinate system is set by a G50 (G code system A) or a G92 (G code system B or C) command or when the manual reference position return is made.

- **Displaying the sixth and subsequent axes**

On 7 soft keys display unit or the shared screen of 12 soft keys display unit, only the coordinates for the first to fifth axes are displayed initially whenever there are six or more controlled axes. Pressing the **[REL]** soft key displays the coordinates for the sixth and subsequent axes. When six or more controlled axes are used under two-path control, the coordinates for path 1 are displayed initially on 7 soft keys display unit. Pressing the **[REL]** soft key displays the coordinates for path 2. On the shared screen of 12 soft key display unit, the tool post selection signal is used to select the display for path 1 or 2.

11.1.3 Overall Position Display

Displays the following positions on a screen : Current positions of the tool in the workpiece coordinate system, relative coordinate system, and machine coordinate system, and the remaining distance. The relative coordinates can also be set on this screen. See subsection III-11.1.2 for the procedure.

Procedure for displaying overall position display screen

- 1 Press function key POS .
- 2 Press soft key **[ALL]**.

- **Display with one-path control
(7 soft keys display unit)**

ACTUAL POSITION	O1000 N00010
(RELATIVE)	(ABSOLUTE)
U 246.912	X 123.456
W 913.780	Z 456.890
(MACHINE)	(DISTANCE TO GO)
X 0.000	X 0.000
Z 0.000	Z 0.000
	PART COUNT 5
RUN TIME 0H15M	CYCLE TIME 0H 0M38S
ACT.F 3000 MM/M	S 0 T0000
MEM **** * * * * *	09:06:35
[ABS] [REL] [ALL] [HNDL] [(OPRT)]	

- **Display with two-path control
(7 soft keys display unit)**

ACTUAL POSITION	O1000 N00010
(RELATIVE)	(ABSOLUTE)
U1 100.000	X1 100.000
W1 200.000	Z1 200.000
U2 300.000	X2 300.000
W2 400.000	Z2 400.000
(MACHINE)	(DISTANCE TO GO)
X1 100.000	X1 000.000
Z1 200.000	Z1 000.000
X2 300.000	X2 000.000
Z2 400.000	Z2 000.000
	PART COUNT 5
RUN TIME 0H15M	CYCLE TIME 0H 0M38S
ACT.F 3000 MM/M	S 0 T0000
MEM **** * * * * *	09:06:35
[ABS] [REL] [ALL] [HNDL] [(OPRT)]	HEAD1

- Display with two-path control (12 soft keys display unit)

O1000 N10010				O2000 N20010			
(RELATIVE)		(ABSOLUTE)		(RELATIVE)		(ABSOLUTE)	
U1	100.000	X1	100.000	U2	100.000	X2	100.000
W1	100.000	Z1	100.000	W2	100.000	Z2	100.000
H1	300.000	C1	300.000	A2	300.000	A2	300.000
V1	400.000	Y1	400.000	B2	400.000	B2	400.000
(MACHINE)		(DISTANCE TO GO)		(MACHINE)		(DISTANCE TO GO)	
X1	100.000	X1	000.000	X2	100.000	X2	000.000
Z1	100.000	Z1	000.000	Z2	100.000	Z2	000.000
C1	300.000	C1	000.000	A2	300.000	A2	000.000
Y1	400.000	Y1	000.000	B2	400.000	B2	000.000
(ACTUAL SPEED) F : OMM/MIN				(ACTUAL SPEED) F : OMM/MIN			
(PARTS COUNT) S : 114				(PARTS COUNT) S : 114			
(RUN TIME) 5H 3M				(RUN TIME) 5H 3M			
(CYCLE TIME) 0H 0M 6S				(CYCLE TIME) 0H 0M 6S			
				MEM STOP *** 12:34:56 HEAD1			
				ABS REL ALL HNDL (OPRT) 			

Explanations

- Coordinate display

The current positions of the tool in the following coordinate systems are displayed at the same time:

- Current position in the relative coordinate system (relative coordinate)
- Current position in the work coordinate system (absolute coordinate)
- Current position in the machine coordinate system (machine coordinate)
- Distance to go (distance to go)

- Distance to go

The distance remaining is displayed in the MEMORY or MDI mode. The distance the tool is yet to be moved in the current block is displayed.

- Machine coordinate system

The least command increment is used as the unit for values displayed in the machine coordinate system. However, the least input increment can be used by setting bit 0 (MCN) of parameter 3104.

- Resetting relative coordinates

On the overall position display screen, relative coordinates can be reset to 0 or preset to specified values. The procedure is the same as that for resetting the relative coordinates described in III-11.1.2.

- Displaying the sixth and subsequent axes

On the shared screen of 12 soft keys display unit, only the coordinates for the first to fifth axes are displayed initially whenever there are six or more controlled axes. Pressing the **[ALL]** soft keys displays the coordinates for the sixth and subsequent axes. On the shared screen of 12 soft keys display unit, the tool post selection signal is used to select the display for path 1 or 2.

- Displaying the fifth and subsequent axes

On 7 soft keys display unit, relative coordinates cannot be displayed together with absolute coordinates when there are five or more controlled axes (when the total number of controlled axes is five or more, for two-path control). Pressing the **[ALL]** soft key toggles the display between absolute and relative coordinates.

11.1.4 Presetting the Workpiece Coordinate System

A workpiece coordinate system shifted by an operation such as manual intervention can be preset using MDI operations to a pre-shift workpiece coordinate system. The latter coordinate system is displaced from the machine zero point by a workpiece zero point offset value.

A command (G92.1) can be programmed to preset a workpiece coordinate system. (See Subsec. III-8.2.4.)

Procedure for Presetting the Workpiece Coordinate System

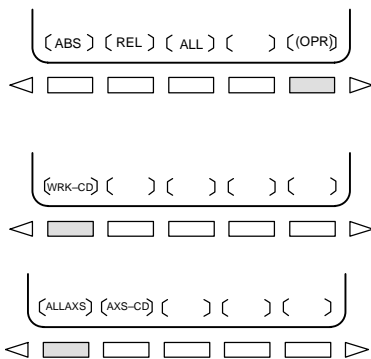

- 1 Press function key **POS**.
- 2 Press soft key **[(OPRT)]**.
- 3 When **[WRK-CD]** is not displayed, press the continuous menu key **[>]**.
- 4 Press soft key **[WRK-CD]**.
- 5 Press soft key **[ALLAXS]** to preset all axes.
- 6 To preset a particular axis in step 5, enter the axis name (**X**, **Y**, ...) and **0**, then press soft key **[AXS-CD]**.

Explanations

- **Operation mode**
- **Presetting relative coordinates**

This function can be executed when the reset state or automatic operation stop state is entered, regardless of the operation mode.

As with absolute coordinates, bit 3 (PPD) of parameter No. 3104 is used to specify whether to preset relative coordinates (RELATIVE).

11.1.5 Actual Feedrate Display

The actual feedrate on the machine (per minute) can be displayed on a current position display screen or program check screen by setting bit 0 (DPF) of parameter 3015. On 12 soft keys display unit, the actual feedrate is always displayed.

Display procedure for the actual feedrate on the current position display screen

- 1 Press function key POS to display a current position display screen.

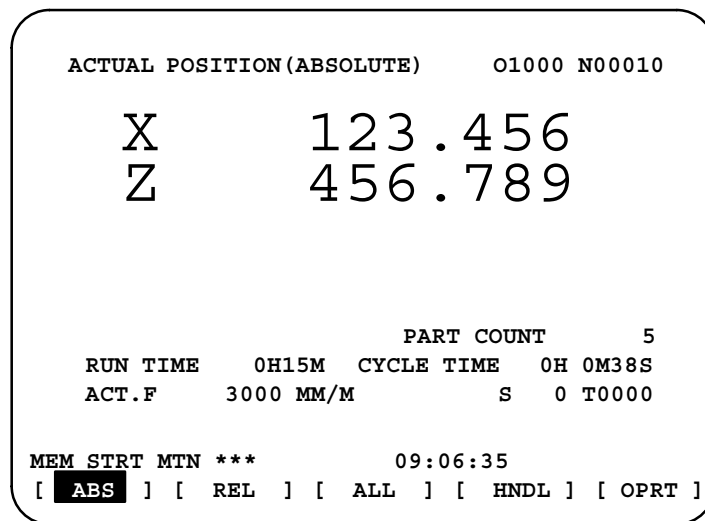

Actual feedrate is displayed after ACT.F.

The actual feedrate is displayed in units of millimeter/min or inch/min (depending on the specified least input increment) under the display of the current position.

Explanations

- Actual feedrate value

The actual rate is calculated by the following expression:

$$Fact = \sqrt{\sum_{i=1}^n (fi)^2}$$

where

n : Number of axes

fi : Cutting feed rate in the tangential direction of each axis or rapid traverse rate

Fact : Actual feedrate displayed

The display unit: mm/min (metric input).

inch/min (Inch input, Two digits below the decimal point are displayed.)

The feedrate along the PMC axis can be omitted by setting bit 1 (PCF) of parameter 3105.

- **Actual feedrate display of feed per revolution**

In the case of feed per revolution and thread cutting, the actual feedrate displayed is the feed per minute rather than feed per revolution.

- **Actual feedrate display of rotary axis**

In the case of movement of rotary axis, the speed is displayed in units of deg/min but is displayed on the screen in units of input system at that time. For example, when the rotary axis moves at 50 deg/min, the following is displayed: 0.50 INCH/M

- **Actual feedrate display on the other screen**

The program check screen also displays the actual feedrate.

11.1.6 Display of Run Time and Parts Count

The run time, cycle time, and the number of machined parts are displayed on the current position display screens.

Procedure for displaying run time and parts count on the current position display screen

- 1 Press function key POS to display a current position display screen.

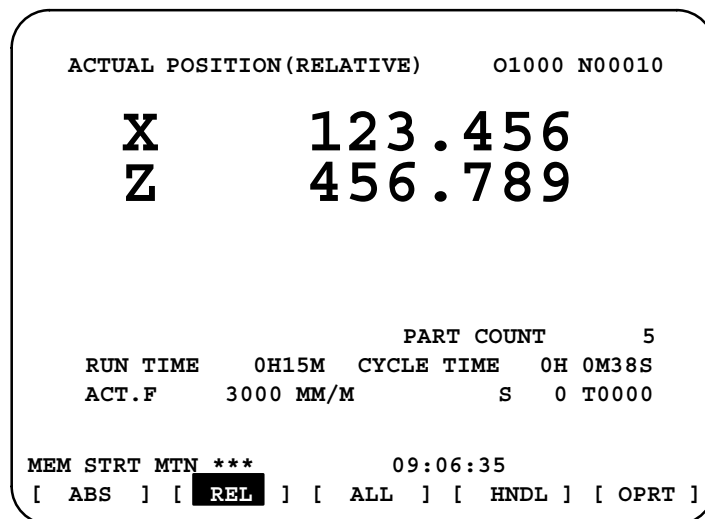

The number of machined parts (PART COUNT), run time (RUN TIME), and cycle time (CYCLE TIME) are displayed under the current position.

Explanations

- **PART COUNT** Indicates the number of machined parts. The number is incremented each time M02, M30, or an M code specified by parameter 6710 is executed.
- **RUN TIME** Indicates the total run time during automatic operation, excluding the stop and feed hold time.
- **CYCLE TIME** Indicates the run time of one automatic operation, excluding the stop and feed hold time. This is automatically preset to 0 when a cycle start is performed at reset state. It is preset to 0 even when power is removed.
- **Display on the other screen** Details of the run time and the number of machined parts are displayed on the setting screen. See subsection III-11.4.9.
- **Parameter setting** The number of machined parts and run time cannot be set on current position display screens. They can be set by parameters 6711, 6751, and 6752 or on the setting screen.
- **Incrementing the number of machined parts** Bit 0 (PCM) of parameter 6700 is used to specify whether the number of machined parts is incremented each time M02, M30, or an M code specified by parameter 6710 is executed, or only each time an M code specified by parameter 6710 is executed.

11.1.7 Setting the Floating Reference Position

To perform floating reference position return with a G30.1 command, the floating reference position must be set beforehand.

Procedure for setting the floating reference position

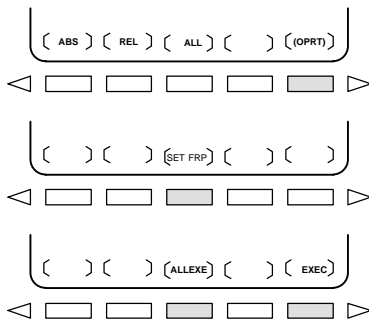

- 1 Press function key **POS** to display a screen used for displaying the current position. Any of the following three screens may be selected: The screen for displaying the current position in the relative coordinate system, screen for displaying the current position in the workpiece coordinate system, and screen for displaying the current positions in four different coordinate systems.
- 2 Move the tool to the floating reference position by jogging.
- 3 Press soft key **[(OPRT)]**.
- 4 Press soft key **[SET FRP]**.
- 5 To register the floating reference positions for all axes, press soft key **[ALLEXE]**.
To register the floating reference position of a specific axis, enter the name of the axis (**X**, etc.), then press soft key **[EXEC]**. Two or more names can be entered consecutively (e.g., **X** **Y** **Z** **[EXEC]**).
The above operation stores the floating reference position. It can be checked with parameter (No. 1244).
- 6 In step 4, the floating reference position along a specified axis can also be stored by entering the axis name (such as **X**) and pressing soft key **[SET FRP]**.

Explanations



- **Presetting the relative coordinate system**

By parameter FPC (bit 3 of parameter 1201), the relative position can be preset to 0 when a floating reference position is registered.

11.1.8 Operating Monitor Display

The reading on the load meter can be displayed for each servo axis and the serial spindle by setting bit 5 (OPM) of parameter 3111 to 1. The reading on the speedometer can also be displayed for the serial spindle.

Procedure for displaying the operating monitor

- 1 Press function key  to display a current position display screen.
- 2 Press the continuous-menu key .
- 3 Press soft key **[MONI]**.

```

OPERATING MONITOR                                00001 N00001
(LOAD METER)

X : █████ * * * 80% S1 : █████ 201%
Z : * * * * * 0%      (SPEED METER RPM)
C : * * * * * 0% S1 : * * *
1500
                                PART COUNT      5
RUN TIME      0H15M  CYCLE TIME  0H 0M38S
ACT.F        3000 MM/M

MEM STRT MTN ***                                09:06:35
[ MONI ] [ REL ] [ ALL ] [ HNDL ] [ OPRT ]

```

Explanations

- **Display of the servo axes** The reading on the load meter can be displayed for up to three servo axes by setting parameters 3151 to 3158. When all these parameters are set to 0, data is displayed only for the basic axes.
- **Display of the spindle axes** When serial spindles are used, the reading on the load meter and speedometer can be displayed only for the main serial spindle.
- **Unit of graph** The bar graph for the load meter shows load up to 200% (only a value is displayed for load exceeding 200%). The bar graph for the speedometer shows the ratio of the current spindle speed to the maximum spindle speed (100%).

- **Load meter**

The reading on the load meter depends on servo parameter 2086 and spindle parameter 4127.

- **Speed meter**

Although the speedometer normally indicates the speed of the spindle motor, it can also be used to indicate the speed of the spindle by setting bit 6 (OPS) of parameter 3111 to 1.

The spindle speed to be displayed during operation monitoring is calculated from the speed of the spindle motor (see the formula below). The spindle speed can therefore be displayed, during operation monitoring, even when no position coder is used. To display the correct spindle speed, however, the maximum spindle speed for each gear (spindle speed at each gear ratio when the spindle motor rotates at the maximum speed) must be set in parameters No. 3741 to 3744.

The input of the clutch and gear signals for the first serial spindle is used to determine the gear which is currently selected. Control the input of the CTH1A and CTH2A signals according to the gear selection, by referring to the table below.

(Formula for calculating the spindle speed to be displayed)

$$\text{Spindle speed displayed during operation monitoring} = \frac{\text{Speed of spindle motor}}{\text{Maximum speed of spindle motor}} \times \text{Maximum spindle speed with the gear being used}$$

The following table lists the correspondence between clutch and gear selection signals CTH1A and CTH2A <G070#3, #2>, used to determine the gear being used, and parameters:

CTH1A	CTH2A	Parameter	Serial spindle specification
0	0	=No.3741 (Maximum spindle speed with gear 1)	HIGH
0	1	=No.3742 (Maximum spindle speed with gear 2)	MEDIUM HIGH
1	0	=No.3743 (Maximum spindle speed with gear 3)	MEDIUM LOW
1	1	=No.3744 (Maximum spindle speed with gear 4)	LOW

The speed of the spindle motor and spindle can be displayed, during operation monitoring, only for the first serial spindle and the spindle switching axis for the first serial spindle. It cannot be displayed for the second spindle.

- **Color of graph**

On a color CRT, if the value of a load meter exceeds 100%, the bar graph turns purple.

11.2 SCREENS DISPLAYED BY FUNCTION KEY (IN MEMORY MODE OR MDI MODE)

This section describes the screens displayed by pressing function key  in MEMORY or MDI mode. The first four of the following screens display the execution state for the program currently being executed in MEMORY or MDI mode and the last screen displays the command values for MDI operation in the MDI mode:

- 11.2.1 Program contents display screen
- 11.2.2 Current block display screen
- 11.2.3 Next block display screen
- 11.2.4 Program check screen
- 11.2.5 Program screen for MDI operation
- 11.2.6 Stamping the machining time
- 11.2.7 Displaying the B-axis operation state

Function key  can also be pressed in MEMORY mode to display the program restart screen and scheduling screen.
See Section III-4.3 for the program restart screen.
See Section III-4.4 for the scheduling screen.

11.2.1 Program Contents Display

Displays the program currently being executed in MEMORY or MDI mode.

Procedure for displaying the program contents

- 1 Press function key  to display a program screen.
- 2 Press chapter selection soft key **[PRGRM]**.
The cursor is positioned at the block currently being executed.

```

PROGRAM                                O2000 N00130
O2000 ;
N100 G50 X0 Z0. ;
N110 G91 G00 X-70. ;
N120 Z-70. ;
N130 G01 X-60 ;
N140 G41 G03 X-17.5 Z17.5 R17.5 ;
N150 G01 X-25. ;
N160 G02 X27.5 Z27.5 R27.5
N170 G01 X20. ;
N180 G02 X45. Z45. R45. ;

> _                                     S 0 T0000
MEM STRT ***                          16:05:59
[ PRGRM ] [ CHECK ] [ CURRNT ] [ NEXT ] [ (OPRT) ]

```

Explanations

- 12 soft keys display unit

On 12 soft keys display unit, the contents of the program are displayed on the right half of the screen or on the entire screen (switched each time soft key **[PRGRM]** is pressed).

```

PROGRAM                                00006 N00000
O0003 ;
G65 H01 P#2001 O0 ;
G65 H01 P#2014 O0 ;
G65 H01 P#2110 O0 ;
G04 P2000 ;
G04 P2000 ;
G04 P2000 ;
G65 H01 P#2001 O50000 ;
G65 H01 P#2014 O60000 ;
G65 H01 P#2110 O30000 ;
G04 P2000 ;
G04 P2000 ;
G04 P2000 ;
G65 H02 P#2001 O#2001 R3 ;
G65 H03 P#2014 O15000 R#2014 ;
G65 H04 P#2110 O3 R#2110 ;

G65 H01 P#100 O#3901 ;
G65 H01 P#101 O#3902 ;
G65 H01 P#3901 O#102 ;
G65 H01 P#3902 O#103 ;
G04 P5000 ;
G04 P5000 ;
G04 ;
G65 H01 P#100 O#4001 ;
G65 H01 P#101 O#4002 ;
/ G65 H01 P#102 O#4003 ;
G65 H01 P#103 O#4004 ;
G65 H01 P#104 O#4005 ;
G65 H01 P#105 O#4006 ;
G65 H01 P#106 O#4007 ;
G65 H01 P#107 O#4008 ;
G65 H01 P#108 O#4009 ;

MEM **** * 07:12:55

```



11.2.2 Current Block Display Screen

Displays the block currently being executed and modal data in the MEMORY or MDI mode.

Procedure for displaying the current block display screen

- 1 Press function key  .
- 2 Press chapter selection soft key **[CURRNT]**.
The block currently being executed and modal data are displayed.
The screen displays up to 22 modal G codes and up to 11 G codes specified in the current block.

```

PROGRAM                                O2000 N00130
      (CURRNT)      (MODAL)
G01 ·X 100.500  G18 G00 F
      ·F 50.000  G50.2G97
                        G13.1G69
                        G99
                        G21 T
                        G40 S
                        G25
                        G22
                        G80
                        G67 SACT 0
                        G54
> _
MEM STRT  ***          16:05:59
[ PRGRM ] [ CHECK ] [ CURRNT ] [ NEXT ] [ (OPRT) ]

```

Explanations

- 12 soft keys display unit

The current block display screen is not provided for 12 soft keys display unit. Press soft key **[PRGRM]** to display the contents of the program on the right half of the screen. The block currently being executed is indicated by the cursor. Modal data is displayed on the left half of the screen.

The screen displays up to 18 modal G codes.

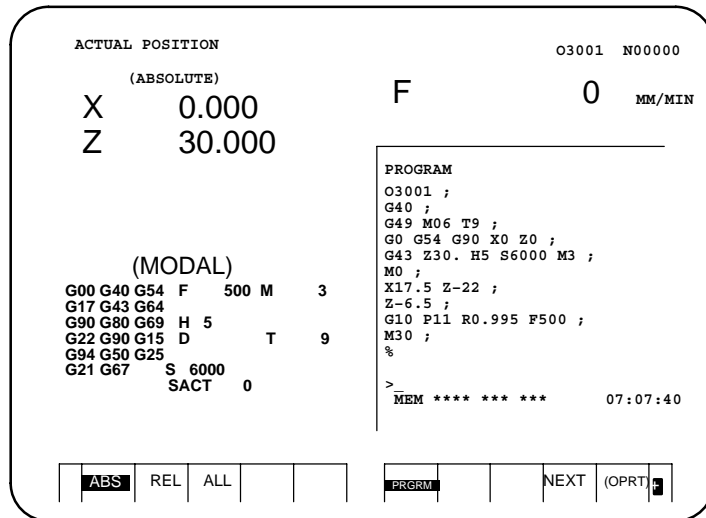

11.2.3 Next Block Display Screen

Displays the block currently being executed and the block to be executed next in the MEMORY or MDI mode.

Procedure for displaying the next block display screen

- 1 Press function key **PROG**.
- 2 Press chapter selection soft key **[NEXT]**.
The block currently being executed and the block to be executed next are displayed.
The screen displays up to 11 G codes specified in the current block and up to 11 G codes specified in the next block.

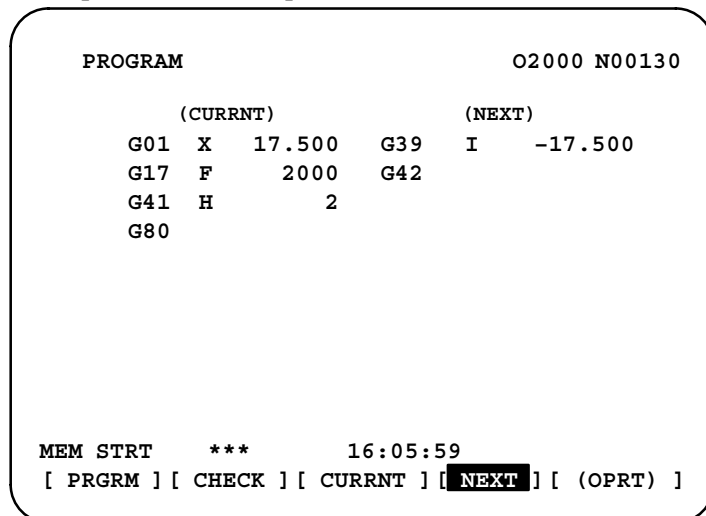

11.2.4 Program Check Screen

Displays the program currently being executed, current position of the tool, and modal data in the MEMORY mode.

Procedure for displaying the program check screen

- 1 Press function key .
- 2 Press chapter selection soft key **[CHECK]**.
The program currently being executed, current position of the tool, and modal data are displayed.

- Display with one-path control

```

PROGRAM                                O2000 N00130
O0010
G92 G90 X100. Z50. ;
G00 X0 Z0 ;
G01 Z250. F1000 ;
(ABSOLUTE) (DIST TO GO) G00 G94 G80
X 0.000 X 0.000 G17 G21 G98
Z 0.000 Z 0.000 G90 G40 G50
                                G22 G67
                                B
                                H M
                                D
T
F S
> _
MEM STRT *** 16:05:59
[ PRGRM ] [ CHECK ] [ CURRNT ] [ NEXT ] [ (OPRT) ]

```

- Display with two-path control
(7 soft keys display unit)

```

PROGRAM                                O2000 N00130
O0010
G92 G90 X100. Z50. ;
G00 X0 Z0 ;
G01 Z250. F1000 ;
(ABSOLUTE) (DIST TO GO) G00 G94 G80
X 0.000 X 0.000 G17 G21 G98
Z 0.000 Z 0.000 G90 G40 G50
                                G22 G67
                                B
                                H M
                                D
T
F S
> _
MEM STRT *** 16:05:59 HEAD1
[ PRGRM ] [ CHECK ] [ CURRNT ] [ NEXT ] [ (OPRT) ]

```

- Display with two path control (12 soft keys display unit)

```

PROGRAM CHECK O1000 N01010          PROGRAM CHECK O2000 N02010
N01000 G90 X100. Z100. ;            N02010 G90 X200. Z200. ;
N01010 G01 X50. Z50. F2000. ;      N02020 G01 X50. Z50. F3000. ;
N01020 X30. ;                       N02030 G01 X50. ;
N01030 X50. Z-40. ;                 N02040 Z-50. ;
N01040 Z-60. ;                       N02050 X0 Z0 A0 B0 ;

(RELATIVE) (ABSOLUTE) (DIST TO GO) (RELATIVE) (ABSOLUTE) (DIST TO GO)
U1 100.000 X1 100.000 X1 0.000      U2 500.000 X2 500.000 X2 0.000
W1 200.000 Z1 200.000 Z1 0.000      W2 600.000 Z2 600.000 Z2 0.000
H1 300.000 C1 300.000 C1 0.000      A2 700.000 A2 700.000 A2 0.000
V1 400.000 Y1 400.000 Y1 0.000      B2 800.000 B2 800.000 B2 0.000

(MODAL)                                (MODAL)
G00 G98 G25 G67 M                      G00 G98 G25 G67 M
G97 G21 G22 G54 M                      G97 G21 G22 G54 M
G69 G40 G90 G18 M                      G69 G40 G90 G18 M
T                                        T
F 3000.000 (ACT.F) OMM/MIN            F 3000.000 (ACT.F) OMM/MIN
S 1000 (ACT.S) ORPM                  S 1000 (ACT.S) ORPM
>_                                  MEM STOP *** ** 14:00:00 HEAD1

```

Explanations

- Program display

The screen displays up to four blocks (five blocks on 12 soft keys display unit when two-path control is being used) of the current program, starting from the block currently being executed. The block currently being executed is displayed in reverse video. During DNC operation, however, only three blocks can be displayed.

- Current position display

The position in the workpiece coordinate system or relative coordinate system and the remaining distance are displayed. The absolute positions and relative positions are switched by soft keys **[ABS]** and **[REL]**. On 7 soft keys display unit when there are six or more controlled axes, pressing the **[ABS]** soft key toggles the display between the absolute coordinates for the first to fifth axes and those for the sixth to eighth axes. Pressing the **[REL]** soft key toggles the relative coordinate display in the same way.

- Modal G codes

Up to 12 modal G codes are displayed. (12 G codes for each path, on 12 soft keys display unit when two-path control is being used)

- Displaying during automatic operation

During automatic operation, the actual speed, SCAT, and repeat count are displayed. The key input prompt (>_) is displayed otherwise.

● **12 soft keys display unit with one-path control**

The program check screen is not provided for 12 soft keys display unit with one-path control. Press soft key **[PRGRM]** to display the contents of the program on the right half of the screen. The block currently being executed is indicated by the cursor. The current position of the tool and modal data are displayed on the left half of the screen.

Up to 18 modal G codes are displayed.

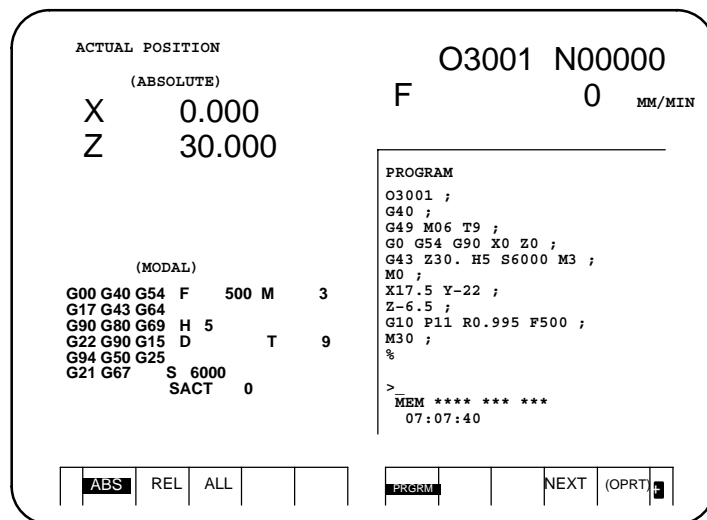

11.2.5 Program Screen for MDI Operation

Displays the program input from the MDI and modal data in the **MDI** mode.

Procedure for displaying the program screen for MDI operation

- 1 Press function key .
- 2 Press chapter selection soft key **[MDI]**.
The program input from the MDI and modal data are displayed.

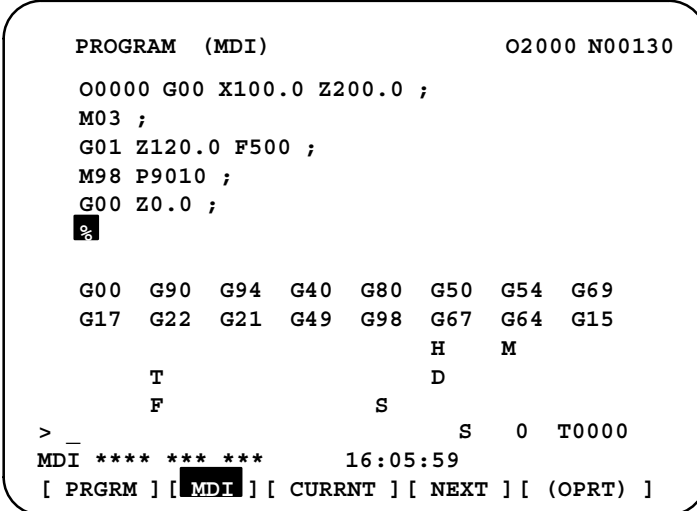

The screenshot shows a split-screen display. The top half, labeled 'Program', contains G-code: O2000 N00130, O0000 G00 X100.0 Z200.0 ; M03 ; G01 Z120.0 F500 ; M98 P9010 ; G00 Z0.0 ; followed by a '%' symbol. The bottom half, labeled 'Modalinformation', shows various modal codes: G00 G90 G94 G40 G80 G50 G54 G69, G17 G22 G21 G49 G98 G67 G64 G15, H M, T D, F S, and S 0 T0000. At the bottom, it shows '> _ MDI **** * * * * 16:05:59' and a row of soft keys: [PRGRM] [MDI] [CURRNT] [NEXT] [(OPRT)].

Explanations



- **MDI operation** See Section II-4.2 for MDI operation.
- **Modal information** The modal data is displayed when bit 7 (MDL) of parameter 3107 is set to 1. Up to 16 modal G codes are displayed. On 12 soft keys display unit, however, the contents of the program are displayed on the right half of the screen and the modal data is displayed on the left half of the screen, regardless of this parameter.
- **Displaying during automatic operation** During automatic operation, the actual speed, SCAT, and repeat count are displayed. The key input prompt (>_) is displayed otherwise.

11.2.6 Stamping the Machining Time

When a machining program is executed, the machining time of the main program is displayed on the program machining time display screen. The machining times of up to ten main programs are displayed in hours/minutes/seconds. When more than ten programs are executed, data for the oldest programs is discarded.

Procedure for Stamping Machining Time

Procedure 1 Machining time calculation and display

- 1 Select the memory operation mode, then press the  key.
- 2 Select the program screen, then select a program whose machining time is to be calculated.
- 3 Execute the program to perform actual machining.
- 4 When the  key is pressed, or M02 or M30 is executed, the machining time count operation stops. When the machining time display screen is selected, the program number of the stopped main program and its machining time are displayed.
To display the machining time display screen, use the procedure below. (Machining time data can be displayed in any mode and during background editing.)
 - Press the function key .
 - Press the rightmost soft key once or twice to display soft key **[TIME]**.
 - Press soft key **[TIME]**. The machining time display screen appears.

Machining time display screen

PROGRAM (TIME)		O0010 N0002	
NO.	TIME		
O0020	12H48M02S		
> _		16:52:13	
EDIT **** * * * *			
[TIME]	[]	[]	[(OPRT)]

- 5 To calculate the machining times of additional programs, repeat the above procedure. The machining time display screen displays the executed main program numbers and their machining times sequentially.

Note, that machining time data cannot be displayed for more than ten main programs. When more than ten programs are executed, data for the oldest programs is discarded. The screens below show how the screen display changes from the initial state where the machining times of ten main programs (O0020, O0040, ..., and O0200) are displayed to the state where the machining time of the main program O0220 is calculated.

```

PROGRAM (TIME)                                O0000 N0000

  NO.      TIME
O0020     12H48M01S
O0040      0H48M01S
O0060      4H16M01S
O0080      0H16M01S
O0100      1H20M01S
O0120      2H08M02S
O0140      2H32M01S
O0160      0H51M01S
O0180     15H04M01S
O0200      0H56M01S

>_
EDIT **** *** ***      16:52:13
[ TIME ] [      ] [      ] [      ] [ (OPRT) ]

```



```

PROGRAM (TIME)                                O0000 N0000

  NO.      TIME
O0040      0H48M01S
O0060      4H16M01S
O0080      0H16M01S
O0100      1H20M01S
O0120      2H08M02S
O0140      2H32M01S
O0160      0H51M01S
O0180     15H04M01S
O0200      0H56M01S
O0220      0H03M01S

>_
EDIT **** *** ***      16:52:20
[ TIME ] [      ] [      ] [      ] [ (OPRT) ]

```

Procedure 2 Stamping machining time

- 1 To insert the calculated machining time of a program in a program as a comment, the machining time of the program must be displayed on the machining time display screen. Before stamping the machining time of the program, check that the machining time display screen shows the program number
- 2 Set the part program storage and edit mode or background edit state and select the program screen. Then select the program whose machining time is to be inserted.
- 3 Suppose that the machining time of O0100 is displayed on the machining time display screen. Press soft key **[(OPRT)]** to display the operation soft keys. Then, hold down the rightmost soft key until soft key **[INS-TM]** appears. When soft key **[INS-TM]** is pressed, the cursor moves to the start of the program, and the machining time of the program is inserted after the program number.

```

PROGRAM                                O0100 N0000

O0100 ;
N10 G92 X100. Z10. ;
N20 S1500 M03 ;
N30 G00 X20.5 Z5. T0101 ;
N40 G01 X-10. F25. ;
N50 G02 X-16.5 Z-12. R2. ;
N60 G01 X40. ;
N70 X42. Z-13. ;
N80 Z-50. ;
N90 X44. Z-51. ;
N100 X80. ;

EDIT   *** *** *** ***                16:05:59
[  INS-TM  ] [ ] [ ] [ ] [ ] [ ] [ ] [ ]

```



```

PROGRAM                                O0100 N0000

O0100 (001H20M01S) ;
N10 G92 X100. Z10. ;
N20 S1500 M03 ;
N30 G00 X20.5 Z5. T0101 ;
N40 G01 Z-10. F25. ;
N50 G02 X16.5 Z-12. R2. ;
N60 G01 X40. ;
N70 X42. Z-13. ;
N80 Z-50. ;
N90 X44. Z-51. ;
N100 X80. ;

EDIT   *** *** *** ***                16:05:59
[  INS-TM  ] [ ] [ ] [ ] [ ] [ ] [ ] [ ]

```

- 4 If a comment already exists in the block containing the program number of a program whose machining time is to be inserted, the machining time is inserted after the existing comment.

```

PROGRAM                                00100 N0000
O0100 (SHAFT XSF001) ;
N10 G92 X100. Z10. ;
N20 S1500 M03 ;
N30 G00 X20.5 Z5. T0101 ;
N40 G01 X-10. F25. ;
N50 G02 X16.5 Z-12. R2. ;
N60 G01 X40. ;
      X42. Z-13. ;
N80 Z-50. ;
N90 X44. Z-51. ;
N100 X80. ;

EDIT   *** ** 16:52:13
[ INS-TM ][      ][      ][      ][      ]

```



```

PROGRAM                                00100 N0000

O0100 (SHAFT XSF001) (001H20M01S) ;
N10 G92 X100. Z10. ;
N20 S1500 M03 ;
N30 G00 X20.5 Z5. T0101 ;
N40 G01 Z-10. F25. ;
N50 G02 X16.5 Z-12. R2. ;
N60 G01 X40. ;
N70 X42. Z-13. ;
N80 Z-50. ;
N90 X44. Z-51. ;
N100 X80. ;

EDIT   *** ** 16:52:13
[ INS-TM ][      ][      ][      ][      ]

```

- 5 The machining time of a program inserted as a comment can be displayed after an existing program comment on the program directory screen.

```

PROGRAM DIRECTORY                       00001 N00010

      PROGRAM (NUM.)      MEMORY (CHAR.)
USED:      60      3321
FREE:      2      429

O0020 (GEAR XGR001 ):(012H48M01S)
O0002 (GEAR XGR002 ):(000H48M01S)
O0010 (BOLT YBT001 ):(004H16M01S)
O0020 (BOLT YBT002 ):(000H16M01S)
O0040 (SHAFT XSF001 ):(001H20M01S)
O0050 (SHAFT XSF002 ):(002H08M01S)
O0100 (SHAFT XSF011 ):(002H32M02S)
O0200 (PLATE XPL100 ):(000H51M01S)

>_
EDIT **** ** 14:46:09
[ PRGRM ][ DIR ][      ][      ][ (OPRT) ]

```

Explanations

- **Machining time**

Machining time is counted from the initial start after a reset in memory operation mode to the next reset. If a reset does not occur during operation, machining time is counted from the start to M03 (or M30). However, note that the time during which operation is held is not counted, but the time used to wait for completion of M, S, T, and/or B functions is counted.
- **Stamping the machining time**

The displayed machining time can be inserted (stamped) as a comment in a program stored in memory. Machining time is inserted as a comment after the program number.
- **Program directory**

The machining time inserted after a program number can be displayed on the program directory screen by setting bit 0 (NAM) of parameter No. 3107 to 1. This lets the user know the machining time of each program. This information is useful as reference data when planning processing.

Restrictions

- **Alarm**

When program execution is terminated by an alarm during the machining time count, the machining time until the alarm is released is counted.
- **M02**

If the user specifies that M02 does not reset the CNC but returns completion signal FIN to the CNC to restart the program from the beginning successively (with bit 5 (M02) of parameter No. 3404 set to 0), the machining time count stops when M02 returns completion signal FIN.
- **Stamping the machining time**

When the machining time of a program to be stamped is not displayed on the machining time display screen, the machining time cannot be inserted into the program even if soft key **[INS-TM]** is pressed.

- **Program directory**

When the machining time inserted into a program is displayed on the program directory screen and the comment after the program number consists of only machining time data, the machining time is displayed in both the program name display field and machining time display field. If machining time data is inserted into a program as shown below, the program directory screen does not display the data or displays only part of the data.

Example 1: Program directory screen when a program name longer than 16 characters

```

PROGRAM                                O0100 N0000

O0240 (SHAFT XSF301 MATERIAL=FC25)
      (001H20M01S);
N10 G92 X100. Z10. ;
N20 S1500 M03 ;
N30 G00 X20.5 Z5. T0101 ;
N40 G01 Z-10. F25. ;
N50 G02 X16.5 Z-12. R2. ;
N60 G01 X40. ;
N70 X42. Z-13. ;
N80 Z-50. ;
N90 X44. Z-51. ;

EDIT   *** ** 16:52:13
[ INS-TM ] [ ] [ ] [ ] [ ]

```



All characters after the first 16 characters of the program comment are discarded and the machining time display field is left blank.

```

PROGRAM DIRECTORY                      O0001 N00010

      PROGRAM (NUM.)      MEMORY (CHAR.)
USED:      60      3321
FREE:      2      429
O0240 (SHAFT XSF301 ):( )

>_
EDIT **** ** 16:52:13
[ PRGRM ] [ DIR ] [ ] [ ] [ (OPRT) ]

```

Example 2: Program directory screen when two or more machining times are stamped.

```

PROGRAM                                00260 N0000

00260 (SHAFT XSF302) (001H15M59S)
(001H20M01S) ;
N10 G92 X100. Z10. ;
N20 S1500 M03 ;
N30 G00 X20.5 Z5. T0101 ;
N40 G01 Z-10. F25. ;
N50 G02 X16.5 Z-12. R2. ;
N60 G01 X40. ;
N70 X42. Z-13. ;
N80 Z-50. ;
N90 X44. Z-51. ;

EDIT   ***   ***   ***   ***           16:52:13
[ INS-TM ] [           ] [           ] [           ] [           ]

```



Only the first machining time is displayed.

```

PROGRAM DIRECTORY                       00001 N00010

PROGRAM (NUM.)      MEMORY (CHAR.)
USED:                60                3321
FREE:                 2                 429
00260 (SHAFT XSF302 ):(001H15M59S)

>_
EDIT   ****   ***   ***           16:52:13
[ PRGRM ] [ DIR ] [           ] [           ] [ (OPRT) ]

```

Example 3: Program directory screen when inserted machining time data does not conform to the format hhhHmmMssS (3-digit number followed by H, 2-digit number followed by M, and 2-digit number followed by S, in this order)

```

PROGRAM                                00280 N0000

00280 (SHAFT XSF303) (1H10M59S)
N10 G92 X100. Z10. ;
N20 S1500 M03 ;
N30 G00 X20.5 Z5. T0101 ;
N40 G01 Z-10. F25. ;
N50 G02 X16.5 Z-12. R2. ;
N60 G01 X40. ;
N70 X42. Z-13. ;
N80 Z-50. ;
N90 X44. Z-51. ;
N100 X80. ;

EDIT   ***   ***   ***   ***   16:52:13
[ INS-TM ] [           ] [           ] [           ] [           ]

```



The machining time display field is blank.

```

PROGRAM DIRECTORY                      00001 N00010

PROGRAM (NUM.)      MEMORY (CHAR.)
USED:                60                3321
FREE:                 2                429
00260 (SHAFT XSF302 ): (001H15M59S)
00280 (SHAFT XSF303 ): (           )

>_
EDIT ****   ***   ***   16:52:13
[ PRGRM ] [ DIR ] [           ] [           ] [ (OPRT) ]

```

- **Correcting the machining time**

If an incorrect machining time is calculated (such as when a reset occurs during program execution), reexecute the program to calculate the correct machining time. If the machining time display screen displays multiple programs with the same program number, select the machining time of the latest program number for insertion into the program.

11.2.7

Displaying the B-axis Operation State

Displaying the B-axis operation state

- 1 Press the  function key.
- 2 Press the **[CHECK]** chapter selection soft key.
- 3 Press the **[B-DSP]** chapter selection soft key. Then, the B-axis operation state is displayed on the program check screen. The command currently being executed and the next command are displayed.



```

PROGRAM CHECK                O0001 N00001
M102 ;
G00 X10. Z20. ;
G01 X20. Z30. F1000 ;
G04 P1000 ;
(ABSOLUTE) (B-AXIS)  G00  G95  G22
X  40.000 G01(CURR) G97  G21  G80
Z  40.000 B -200.000 G90  G40  G50
Y   0.000 F 0.1500  G69  G25  G67
B -125.994 G00(NEXT)
                B 250.000                M          102

T
F   0.1000      S
ACT.F          0  SCAT      0S      0 T0000
MEM STRT *** FIN      21:20:05
[ ABS ] [ REL ] [ B.DSP ] [      ] [ (OPRT) ]

```



11.3 SCREENS DISPLAYED BY FUNCTION KEY (IN THE EDIT MODE)

This section describes the screens displayed by pressing function key  in the EDIT mode. Function key  in the EDIT mode can display the program editing screen and the program display screen (displays memory used and a list of programs). Pressing function key  in the EDIT mode can also display the conversational graphics programming screen and the floppy file directory screen. See Chapter 9, 10 for the program editing screen and conversational graphics programming screen. See Chapter 8 for the floppy file directory screen.

11.3.1 Displaying Memory Used and a List of Programs

Displays the number of registered programs, memory used, and a list of registered programs.

Procedure for displaying memory used and a list of programs

- 1 Select the **EDIT** mode.
For the two-path control, select the tool post for which a program is to be displayed with the tool post selection switch.
- 2 Press function key .
- 3 Press chapter selection soft key **[LIB]**.

```
PROGRAM DIRECTORY                00001 N00010
```

PROGRAM (NUM.)		MEMORY (CHAR.)	
USED:	60		3321
FREE:	2		429
00010	00001	00003	00002 00555 00999
00062	00004	00005	01111 00969 06666
00021	01234	00588	00020 00040

```
>
MDI **** * 16:05:59
[ PRGRM ][ DIR ][ ] [ (OPRT) ]
```

Explanations

• Details of memory used

PROGRAM NO. USED

PROGRAM NO. USED : The number of the programs registered (including the subprograms)

FREE : The number of programs which can be registered additionally.

MEMORY AREA USED

MEMORY AREA USED : The capacity of the program memory in which data is registered (indicated by the number of characters).

FREE : The capacity of the program memory which can be used additionally (indicated by the number of characters).

• Program library list

Program Nos. registered are indicated.

Also, the program name can be displayed in the program table by setting parameter NAM (No. 3107#0) to 1.

```

PROGRAM DIRECTORY                00001 N00010

      PROGRAM (NUM.)           MEMORY (CHAR.)
USED:         60                3321
FREE:         2                 429

00001 (MACRO-GCODE.MAIN)
00002 (MACRO-GCODE.SUB1)
00010 (TEST-PROGRAM.ARTHMETIC NO.1)
00020 (TEST-PROGRAM.F10-MACRO)
00040 (TEST-PROGRAM.OFFSET)
00050
00100 (INCH/MM CONVERT CHECK NO.1)
00200 (MACRO-MCODE.MAIN)
> _
EDIT **** * 16:05:59
[ PRGRM ][ DIR ] [ ] [ ] [ (OPRT) ]

```

Fig. 11.3.1 (a)

```

PROGRAM DIRECTORY                00001 N00010

      PROGRAM (NUM.)           MEMORY (CHAR.)
USED:         17                4320
FREE:         46                3960

00001 360 1966-06-12 14:40
00002 240 1966-06-12 14:55
00010 420 1966-07-01 11:02
00020 180 1966-08-14 09:40
00040 1140 1966-03-25 28:40
00050 60 1966-08-26 16:40
00100 120 1966-04-30 13:11
> _
EDIT **** * 16:52:13
[ PRGRM ][ DIR ] [ ] [ ] [ (OPRT) ]

```

Fig. 11.3.1 (b)

- **Program name**

Always enter a program name between the control out and control in codes immediately after the program number.

Up to 31 characters can be used for naming a program within the parentheses. If 31 characters are exceeded, the exceeded characters are not displayed.

Only program number is displayed for the program without any program name.

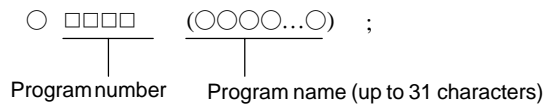

- **Software series**

Software series of the system is displayed.

It is used for maintenance ; user is not required this information.

- **Order in which programs are displayed in the program library list**

Programs are displayed in the same order that they are registered in the program library list. However, if bit 4 (SOR) of parameter 3107 is set to 1, programs are displayed in the order of program number starting from the smallest one.

- **Order in which programs are registered**

Immediately after all programs are cleared (by turning on the power while pressing the  key), each program is registered after the last program in the list.

If some programs in the list were deleted, then a new program is registered, the new program is inserted in the empty location in the list created by the deleted programs.

Example) When bit 4 (SOR) of parameter 3107 is 0

1. After clearing all programs, register programs O0001, O0002, O0003, O0004, and O0005 in this order. The program library list displays the programs in the following order:
O0001, O0002, O0003, O0004, O0005
2. Delete O0002 and O0004. The program library list displays the programs in the following order:
O0001, O0003, O0005
3. Register O0009. The program library list displays the programs in the following order:
O0001, O0009, O0003, O0005

Explanations

• Shared screen and individual screen

When the selected tool post is in **EDIT** mode, pressing the **[PRGRM]** soft key displays a shared screen which shows the program for the first tool post on the left and that for the second tool post on the right. However, if the tool post that is not selected fails to satisfy any of the conditions described below, only the individual screen for the selected tool post is displayed.

<Conditions>

- Bit 0 (DHD) of parameter No. 3106 is set to 1.
- The program screen for the selected tool post is the 12 soft keys display unit
(when the 12 soft keys display unit is being used).
- Both tool posts are set to **EDIT** mode.
- Background editing is not specified for either tool post.

When the mode for the tool post that is not selected is changed from **EDIT** mode on the shared screen, the individual screen (12 soft keys display unit when 12 soft keys display unit is being used) for the selected tool post is displayed.

On the 12 soft keys display unit, pressing the **[PRGRM]** soft key toggles between the individual screen (7 soft keys display unit) and the shared screen.

```

PROGRAM                                O1357 N00130
O1357  (HEAD-1 MAIN PROGRAM) ;
N010   G90 G00 X200.0 Z220.0 ;
N020  T0101 ;
N030  S30000 M03 ;
N040  G40 G00 X40.0 Z180.0 ;
N050  G01 Z140.0 F1000.0 ;
N060  X60.0 Z110.0 ;
N070  Z90.0 ;
N080  X100.0 Z80.0 ;
N090  Z60.0 ;
N100  X140.0 Z40.0 ;

```

```

>_
EDIT **** * 14:25:36
[ BG-EDT ] [ O SRH ] [ SRH↓ ] [ SRH↑ ] [ REWIND ]

```

**Individual screen
(12 soft keys screen on the 12 soft
keys display unit)**

```

PROGRAM O1234 N00010

O1234 ;
N10 G00 ;
N20 X100.0 ;
N30 X200.0 ;
N40 X300.0 Z300.0 ;
N50 X400.0 ;
N60 X500.0 ;
N70 M02 ;
%

>_
EDIT STRT MIN FIN ALM 17:25:01 HEAD1
[ ] [ ] [ ] [ ] [ ] [ ] [ ] [ ] [PRGRM] [ LIB ] [ ] [ ] [(OPR)] [ ]
    
```

**Individual screen
(7 soft keys screen on the 12 soft
keys display unit)**

```

ACTUAL POSITION O1234N00010
                F 1000 MM/M

(ABSOLUTE)     (RELATIVE)
X 0.000        X 0.000
Y 0.000        Y 0.000
Z 0.000        Z 0.000
A 0.000        A 0.000
B 0.000        B 0.000

(MACHINE)
X 0.000
Y 0.000
Z 0.000
A 0.000
B 0.000

G00 G25
G97 G22
G67 G80
G99 G67
G21 G54
G40 G18 SCAT

PROGRAM O1234 N00010
O1234 ;
N10 G00 ;
N20 X100.;
N30 X200.;
N40 X300. Z300.;
N50 X400.;
N60 X500.;
N70 M02 ;
%

>_
EDIT STRT MIN FIN ALM 17:25:01 HEAD1
[ ] [ABS] [REL] [ALL] [ ] [ ] [ ] [PRGRM] [ LIB ] [ ] [ ] [(OPR)] [ ]
    
```

• Editing operation

Editing is enabled only for the program for the selected tool post. The program for the first or second tool post can be edited on the same screen by selecting either tool post with the tool post selection signal.

**• 7 soft keys display unit
shared screen**

On 7 soft keys display unit, the shared screen consists of 80 digits x 25 lines. If the tool post name specified with parameter No. 3131 contains a character other than alphanumeric and special characters (" # \$ % & ' () * + , - . / : ; < = > ? @ [¥] ^ _ and space), the character ! will not be displayed correctly. In such a case, operation soft keys [SRH↑] and [SRH↓] are displayed as [SRH+] and [SRH-].

Limitations

This function cannot be used for background editing.

11.3.3 Displaying a Program List for a Specified Group



In addition to the normal listing of the numbers and names of CNC programs stored in memory, programs can be listed in units of groups, according to the product to be machined, for example.

To assign CNC programs to the same group, assign names to those programs, beginning each name with the same character string.

By searching through the program names for a specified character string, the program numbers and names of all the programs having names including that string are listed.

Procedure for Displaying a Program List for a Specified Group

Procedure

- 1 Enter EDIT or background editing mode.
- 2 Press the  function key.
- 3 Press the  function key or **[DIR]** soft key to display the program list.

```
PROGRAM DIRECTORY          O0001 N00010
      PROGRAM (NUM.)      MEMORY (CHAR.)
USED:           60          3321
FREE:           2           429
```

```
O0020 (GEAR-1000 MAIN)
O0040 (GEAR-1000 SUB-1)
O0060 (SHAFT-2000 MAIN)
O0100 (SHAFT-2000 SUB-1)
O0200 (GEAR-1000 SUB-2)
O1000 (FRANGE-3000 MAIN)
O2000 (GEAR-1000 SUB-3)
O3000 (SHAFT-2000 SUB-2)
```

```
> _
EDIT **** * 16:52:13
[ PRGRM ] [ DIR ] [ ] [ ] [ (OPRT) ]
```

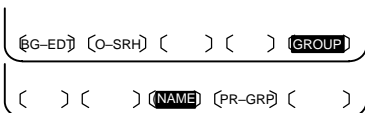

- 4 Press the **[(OPRT)]** operation soft key.
- 5 Press the **[GROUP]** operation soft key.
- 6 Press the **[NAME]** operation soft key.
- 7 Enter the character string corresponding to the group for which a search is to be made, using the MDI keys. No restrictions are imposed on the length of a program name. Note, however, that search is made based on only the first 32 characters.

Example: To search for those CNC programs having names that begin with character string "GEAR-1000," enter the following:

```
>GEAR-1000*_
```

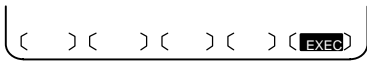
- 8 Pressing the **[EXEC]** operation soft key displays the group-unit program list screen, listing all those programs whose name includes the specified character string.

```

PROGRAM DIRECTORY (GROUP)      O0001 N00010
PROGRAM (NUM.)      MEMORY (CHAR.)
USED:                60          3321
FREE:                2          429

O0020 (GEAR-1000 MAIN)
O0040 (GEAR-1000 SUB-1)
O0200 (GEAR-1000 SUB-2)
O2000 (GEAR-1000 SUB-3)

> _
EDIT **** * 16:52:25
[ PRGRM ] [ DIR ] [ ] [ ] [ (OPRT) ]

```

**[Group-unit program list screen displayed
when a search is made for "GEAR-1000*"]**

When the program list consists of two or more pages, the pages can be changed by using a page key.

Explanations

- * and ?

In the above example, the asterisk (*) must not be omitted. The asterisk indicates an arbitrary character string (wild card specification).

“GEAR-1000*” indicates that the first nine characters of the target program names must be “GEAR-1000,” followed by an arbitrary character string. If only “GEAR-1000” is entered, a search is made only for those CNC programs having the nine-character name “GEAR-1000.”

A question mark (?) can be used to specify a single arbitrary character. For example, entering “????-1000” enables a search to be made for programs having names which start with four arbitrary characters, followed by “-1000”.

[Example of using wild cards]

(Entered character string)	(Group for which the search will be made)
(a) "*"	CNC programs having any name
(b) "*ABC"	CNC programs having names which end with "ABC"
(c) "ABC*"	CNC programs having names which start with "ABC"
(d) "*ABC*"	CNC programs having names which include "ABC"
(e) "?A?C"	CNC programs having four-character names, the second and fourth characters of which are A and C, respectively
(f) "??A?C"	CNC programs having five-character names, the third and fifth characters of which are A and C, respectively
(g) "123*456"	CNC programs having names which start with "123" and which end with "456"

- **When the specified character string cannot be found**
- **Holding the group for which a search is made**
- **Group for which previous search was made**

If no program is located as a result of a search for an entered character string, warning message "DATA NOT FOUND" is displayed on the program list screen.

A group-unit program list, generated by a search, is held until the power is turned off or until another search is performed.

After changing the screen from the group-unit program list to another screen, pressing the **[PR-GRP]** operation soft key (displayed in step 6) redisplay the group-unit program list screen, on which the program names for the previously searched group are listed. Using this soft key eliminates the need to enter the relevant character string again to redisplay the search results after changing the screen.

Examples

Assume that the main programs and subprograms for machining gear part number 1000 all have names which include character string "GEAR-1000." The numbers and names of those programs can be listed by searching through the names of all CNC programs for character string "GEAR-1000." This function facilitates the management of the CNC programs stored in large-capacity memory.

11.4 SCREENS DISPLAYED BY FUNCTION KEY



Press function key  to display or set tool compensation values and other data.

This section describes how to display or set the following data:

1. Tool offset value
2. Settings
3. Run time and part count
4. Workpiece origin offset value or workpiece coordinate system shift value
5. Custom macro common variables
6. Software operator's panel
7. Tool life management data

This section also describes following functions.

- Direct input of tool offset value
- Direct input of tool offset value measured B
- Counter input of offset value
- Direct input of workpiece coordinate system shift
- Y axis offset
- Sequence number comparison and stop function

The following functions depend on the specifications of the machine tool builder. See the manual issued by the machine tool builder for details.

- Direct input of tool offset value
- Direct input of tool offset value measured B
- Software operator's panel
- Tool life management data

11.4.1 Setting and Displaying the Tool Offset Value

Dedicated screens are provided for displaying and setting tool offset values and tool nose radius compensation values.

Procedure for setting and displaying the tool offset value and the tool nose radius compensation value

- 1 Press function key .

For the two-path control, select the tool post for which tool compensation values are to be displayed with the tool post selection switch.

- 2 Press chapter selection soft key **[OFFSET]** or press  several times until the tool compensation screen is displayed. Different screens are displayed depending on whether tool geometry offset, wear offset, or neither is applied.

```

OFFSET                                00001 N00000
NO.      X          Z.          R      T
001      0.000      10.000      0.000  0
002      0.000      0.000      0.000  0
003      0.000      0.000      0.000  0
004      40.000     -40.000      0.000  0
005      0.000      0.000      0.000  0
006      0.000      0.000      0.000  0
007      0.000      0.000      0.000  0
008      0.000      0.000      0.000  0
ACTUAL POSITION (RELATIVE)
U  101.000          W  202.094
> _
MDI **** *** ***      16:05:59
[ OFFSET ] [ SETING ] [ WORK ] [ ] [ (OPRT) ]

```

Without tool geometry/wear offset

```

OFFSET/GEOMETRY                       00001 N00000
NO.      X          Z.          R      T
G 001      0.000      1.000      0.000  0
G 002      1.486     -49.561      0.000  0
G 003      1.486     -49.561      0.000  0
G 004      1.486      0.000      0.000  0
G 005      1.486     -49.561      0.000  0
G 006      1.486     -49.561      0.000  0
G 007      1.486     -49.561      0.000  0
G 008      1.486     -49.561      0.000  0
ACTUAL POSITION (RELATIVE)
U  101.000          W  202.094
> _
MDI **** *** ***      16:05:59
[ WEAR ] [ GEOM ] [ WORK ] [ ] [ (OPRT) ]

```

With tool geometry offset

OFFSET/WEAR		00001 N00000		
NO.	X	Z.	R	T
W 001	0.000	1.000	0.000	0
W 002	1.486	-49.561	0.000	0
W 003	1.486	-49.561	0.000	0
W 004	1.486	0.000	0.000	0
W 005	1.486	-49.561	0.000	0
W 006	1.486	-49.561	0.000	0
W 007	1.486	-49.561	0.000	0
W 008	1.486	-49.561	0.000	0
ACTUAL POSITION (RELATIVE)				
U	101.000	W	202.094	
> _				
MDI **** * * * * *		16:05:59		
[WEAR]	[GEOM]	[WORK]	[]	[(OPRT)]

With tool wear offset

- 3 Move the cursor to the compensation value to be set or changed using page keys and cursor keys, or enter the compensation number for the compensation value to be set or changed and press soft key **[NO.SRH]**.
- 4 To set a compensation value, enter a value and press soft key **[INPUT]**. To change the compensation value, enter a value to add to the current value (a negative value to reduce the current value) and press soft key **[+INPUT]**. Or, enter a new value and press soft key **[INPUT]**. TIP is the number of the virtual tool tip (see Programming). TIP may be specified on the geometry compensation screen or on the wear compensation screen.

Explanations

- **Decimal point input**
- **Other method**
- **Tool offset memory**

A decimal point can be used when entering a compensation value.

An external input/output device can be used to input or output a cutter compensation value. See Chapter III-8.

Tool length compensation values can be set using the following functions described in subsequent subsections: direct input of tool offset value, direct-input function B for tool offset measured, and counter input of offset value.

16 groups are provided for tool compensation. The number of groups can be optionally extended to 32, 64, or 99. For the two-path control, the above number of groups can be used for each tool post. Tool geometry compensation or wear compensation can be selected for each group.

- **Disabling entry of compensation values**

In some cases, tool wear compensation or tool geometry compensation values cannot be input because of the settings in bits 0 (WOF) and 1 (GOF) of parameter 3290. The input of tool compensation values from the MDI can be inhibited for a specified range of offset numbers. The first offset number for which the input of a value is inhibited is set in parameter No. 3294. The number of offset numbers, starting from the specified first number, for which the input of a value is inhibited is set in parameter No. 3295.

Consecutive input values are set as follows:

- 1) When values are input for offset numbers, starting from one for which input is not inhibited to one for which input is inhibited, a warning is issued and values are set only for those offset numbers for which input is not inhibited.
- 2) When values are input for offset numbers, starting from one for which input is inhibited to one for which input is not inhibited, a warning is issued and no values are set.

- **Displaying radius and TIP**

The radius and TIP are not displayed if the tool tip radius compensation option is not displayed.

- **Changing offset values during automatic operation**

When offset values have been changed during automatic operation, bit 4 (LGT) and bit 6 (LWM) of parameter 5002 can be used for specifying whether new offset values become valid in the next move command or in the next T code command.

LGT	LWM	When geometry compensation values and wear compensation values are separately specified	When geometry compensation values and wear compensation values are not separately specified
0	0	Become valid in the next T code block	Become valid in the next T code block
1	0	Become valid in the next T code block	Become valid in the next T code block
0	1	Become valid in the next T code block	Become valid in the next move command
1	1	Become valid in the next move command	Become valid in the next move command

11.4.2 Direct Input of Tool Offset Value

To set the difference between the tool reference position used in programming (the nose of the standard tool, turret center, etc.) and the tool tip position of a tool actually used as an offset value

Procedure for direct input of tool offset value

- **Setting of Z axis offset value**

- 1 Cut surface A in manual mode with an actual tool.
Suppose that a workpiece coordinate system has been set.

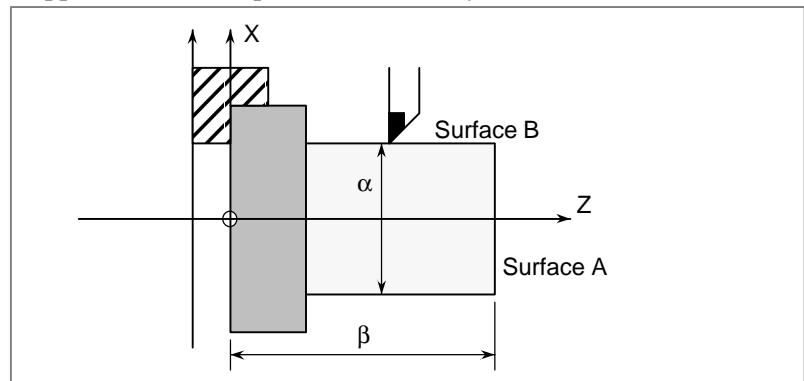

- 2 Release the tool in X-axis direction only, without moving Z-axis and stop the spindle.
- 3 Measure distance β from the zero point in the workpiece coordinate system to surface A.
Set this value as the measured value along the Z-axis for the desired offset number, using the following procedure:

```



OFFSET/GEOMETRY                                00001 N0000
NO.      X      Z.      R      T
G 001    0.000    1.000    0.000  0
G 002    1.486   -49.561    0.000  0
G 003    1.486   -49.561    0.000  0
G 004    1.486    0.000    0.000  0
G 005    1.486   -49.561    0.000  0
G 006    1.486   -49.561    0.000  0
G 007    1.486   -49.561    0.000  0
G 008    1.486   -49.561    0.000  0
ACTUAL POSITION (RELATIVE)
U      0.000      W      0.000
V      0.000      H      0.000

```

```

>MZ120._
MDI **** * 16:05:59
[NO,SRH] [MEASUR] [INP.C.] [+INPUT] [INPUT]

```

- 3-1 Press the function key  or the soft key **[OFFSET]** to display the tool compensation screen. If geometry compensation values and wear compensation values are separately specified, display the screen for either of them.
- 3-2 Move the cursor to the set offset number using cursor keys.
- 3-3 Press the address key  to be set.

- 3-4 Key in the measured value (β).
 - 3-5 Press the soft key **[MEASURE]**.
The difference between measured value β and the coordinate is set as the offset value.
- **Setting of X axis offset value**
 - 4 Cut surface B in manual mode.
 - 5 Release the tool in the Z-axis direction without moving the X-axis and stop the spindle.
 - 6 Measure the diameter α of surface B.
Set this value as the measured value along the X-axis for the desired offset number in the same way as when setting the value along the Z-axis.
 - 7 Repeat above procedure the same time as the number of the necessary tools. The offset value is automatically calculated and set.
For example, in case $\alpha=69.0$ when the coordinate value of surface B in the diagram above is 70.0, set 69.0 **[MEASURE]** at offset No. 2.
In this case, 1.0 is set as the X-axis offset value to offset No. 2.

Explanations

- **Compensation values for a program created in diameter programming**
Enter diameter values for the compensation values for axes for which diameter programming is used.
- **Tool geometry offset value and tool wear offset value**
If measured values are set on the tool geometry compensation screen, all compensation values become geometry compensation values and all wear compensation values are set to 0. If measured values are set on the tool wear compensation screen, the differences between the measured compensation values and the current wear compensation values become the new compensation values.
- **Retracting along two axes**
If a record button is provided on the machine, the tool can retract along two axes when bit 2 (PRC) of parameter 5005 is set and the record signal is used. Refer to the appropriate manual issued by the machine tool builder.

11.4.3 Direct Input of tool offset measured B

The direct input function B for tool offset measured is used to set tool compensation values and workpiece coordinate system shift values.

Procedure for setting the tool offset value

Tool position offset values can be automatically set by manually moving the tool until it touches the sensor.

Refer to the appropriate manual issued by the machine tool builder for actual operation.

- 1** Execute manual reference position return.
By executing manual reference position return, a machine coordinate system is established.
The tool offset value is computed on the machine coordinate system.
- 2** Set the offset writing mode signal GOQSM to HIGH.
(Refer to the appropriate manual issued by the machine tool builder for actual operation.)
The CRT display is automatically changed to the tool offset screen (geometry), and the "OFST" indicator starts blinking in the status indication area in the bottom of the screen, which informs that the offset writing mode is ready.
- 3** Select a tool to be measured.
- 4** When the cursor is not coincided with the tool offset number desired to be set, move the cursor to the desired offset number by page key and cursor key.
Besides the cursor can also be coincided with the tool offset number desired to set automatically by the tool offset number input signals (when parameter QNI(No. 5005#5)=1).
In this case, the position of the cursor cannot be changed on the tool compensation screen using page keys or cursor keys.
- 5** Near the tool to the sensor by manual operation.
- 6** Place the tool edge to a contacting surface of the sensor by manual handle feed.
Bring the tool edge in contact with the sensor. This causes the offset writing signals (+ MIT1, - MIT1, + MIT2 or - MIT2) to input to CNC.
The offset writing signal is set to HIGH, and the :
 - The axis is interlocked in this direction and its feeding is stopped.
 - The tool offset value extracted by the tool offset memory (tool geometry offset value) which corresponds to the offset number shown by the cursor is set up.
- 7** For both X-axis and Z-axis, their offset value are set by the operations **5** and **6**.
- 8** Repeat operations **3** to **7** for necessary tools.

- 9 Set the offset writing signal mode GOQSM to LOW.
The writing mode is canceled and the blinking “OFST” indicator light goes off.

Procedure for setting the work coordinate system shift amount

Tool position offset values can be automatically set by manually moving the tool until it touches the sensor.

Refer to the appropriate manual issued by the machine tool builder for actual operation.

- 1 The tool compensation values are then calculated based on the machine coordinates of the tool.
- 2 Execute manual reference position return.
By executing manual reference position return, the machine coordinate system is established.
The workpiece coordinate system shifting amount is computed based on the machine coordinate system of the tool.
- 3 Set the workpiece coordinate system shifting amount writing signal mode WOQSM to HIGH.
(Refer to the appropriate manual issued by the machine tool builder for actual operation.)
The CRT display is automatically switches to the workpiece shifting screen, the “WFST” indicator starts blinking at the status indicator area in the bottom of the screen, which inform that the workpiece coordinate system shifting amount writing mode is ready.
- 4 Select a tool to be measured.
- 5 Check tool offset numbers.
The tool offset number corresponding to the tool required for measurement, shall be set in the parameter (No. 5020) in advance.
Besides the tool offset number can be set automatically by setting the tool offset number input signal (with parameter QNI (No. 5005#5)=1).
Refer to the appropriate manual issued by the machine tool builder for details.
- 6 Manually approach the tool to an end face of the workpiece.
- 7 Place the tool edge to the end face (sensor) of the workpiece by manual handle feed.
The workpiece coordinate system shifting amount on the Z-axis is automatically set.
- 8 Feed the tool.
- 9 Set the workpiece coordinate system shifting amount writing signal mode WOQSM to LOW.
The writing mode is canceled and the blinking “WSFT” indicator light goes off.
(Refer to the appropriate manual issued by the machine tool builder for actual operation.)

11.4.4 Counter Input of Offset value

By moving the tool until it reaches the desired reference position, the corresponding tool offset value can be set.

Procedure for counter input of offset value

- 1 Manually move the reference tool to the reference position.
- 2 Reset the relative coordinates along the axes to 0 (see subsec. III-11.1.2).
- 3 Move the tool for which offset values are to be set to the reference position.
- 4 Select the tool compensation screen. Move the cursor to the offset value to be set using cursor keys.

OFFSET/GEOMETRY			O0001 N00000	
NO.	X	Z.	R	T
G 001	0.000	1.000	0.000	0
G 002	1.486	-49.561	0.000	0
G 003	1.486	-49.561	0.000	0
G 004	1.486	0.000	0.000	0
G 005	1.486	-49.561	0.000	0
G 006	1.486	-49.561	0.000	0
G 007	1.486	-49.561	0.000	0
G 008	1.486	-49.561	0.000	0
ACTUAL POSITION (RELATIVE)				
U	0.000	W	0.000	
V	0.000	H	0.000	
>X_				
HND **** * * * *			16:05:59	
[NO,SRH] [MEASUR] [INP.C.] [+INPUT] [INPUT]				

- 5 Press address key **X** (or **Z**) and the soft key **[INP.C.]**.

Explanations

- **Geometry offset and wear offset**



When the above operations are performed on the tool geometry compensation screen, tool geometry compensation values are input and tool wear compensation values do not change.

When the above operations are performed on the tool wear compensation screen, tool wear compensation values are input and tool geometry compensation values do not change.

11.4.5 Setting the Workpiece Coordinate System Shifting Amount

The set coordinate system can be shifted when the coordinate system which has been set by a G50 command (or G92 command for G code system B or C) or automatic coordinate system setting is different from the workpiece coordinate system assumed at programming.

Procedure for setting the workpiece coordinate system shifting amount

- 1 Press function key  .
- 2 Press the continuous menu key  several times until the screen with soft key **[WK.SHFT]** is displayed.

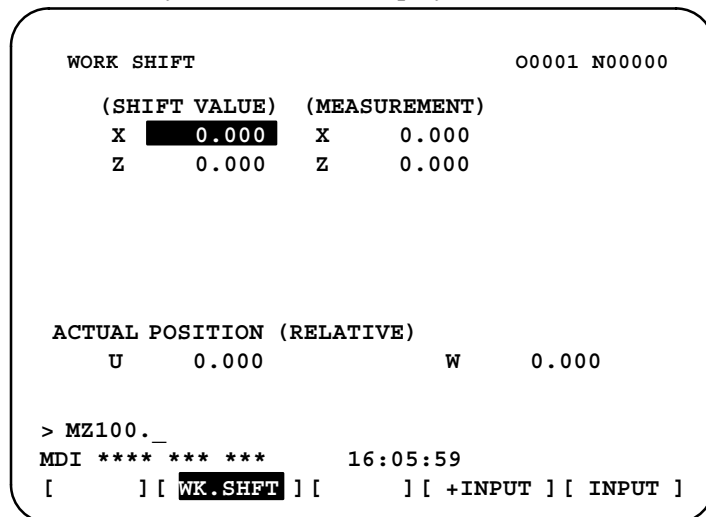

- 3 Press soft key **[WK.SHFT]**.
- 4 Move the cursor using cursor keys to the axis along which the coordinate system is to be shifted.
- 5 Enter the shift value and press soft key **[INPUT]**.

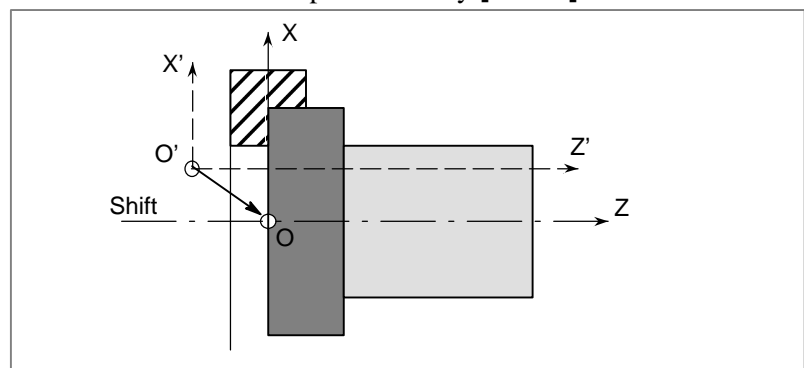

Explanations

- **When shift values become valid**

Shift values become valid immediately after they are set.

- **Shift values and coordinate system setting command**

Setting a command (G50 or G92) for setting a coordinate system disables the set shift values.

Example When G50 X100.0 Z80.0; is specified, the coordinate system is set so that the current tool reference position is X = 100.0, Z = 80.0 regardless of the shift values.

- **Shift values and coordinate system setting**

If the automatic coordinate system setting is performed by manual reference position return after shift amount setting, the coordinate system is shifted instantly.

- **Diameter or radius value**

Whether the shift amount on the X-axis is diameter or radius value depends on that specified in program.

Examples

When the actual position of the reference point is X = 121.0 (diameter), Z = 69.0 with respect to the workpiece origin but it should be X = 120.0, Z = 70.0, set the following shift values:
X = 1.0, Z = - 1.0

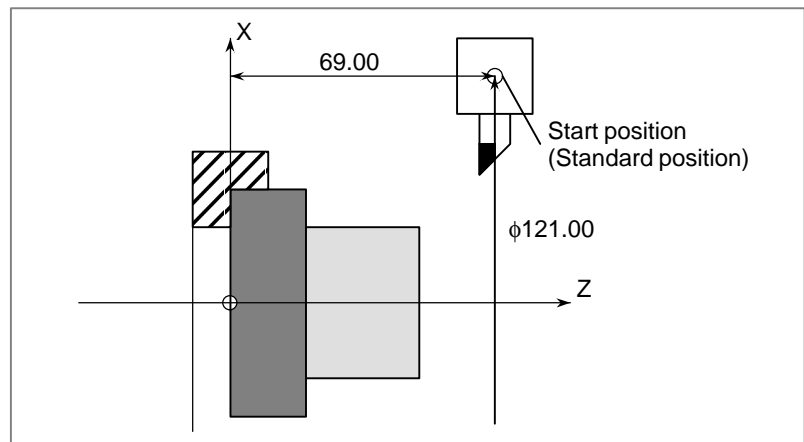



11.4.6 Y Axis Offset

Tool position offset values along the Y-axis can be set. Counter input of offset values is also possible.

Direct input of tool offset value and direct input function B for tool offset measured are not available for the Y-axis.

Procedure for setting the tool offset value of the Y axis

- 1 Press function key .
- 2 Press the continuous menu key  several times until the screen with soft key **[OFST.2]** is displayed.
- 3 Press soft key **[OFST.2]**.
The Y axis offset screen is displayed.

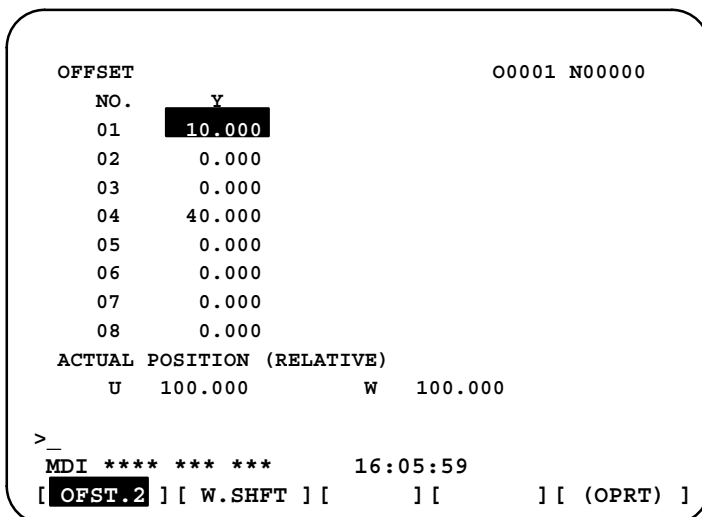

- 3-1 Press soft key **[GEOM]** to display the tool geometry compensation values along the Y-axis.

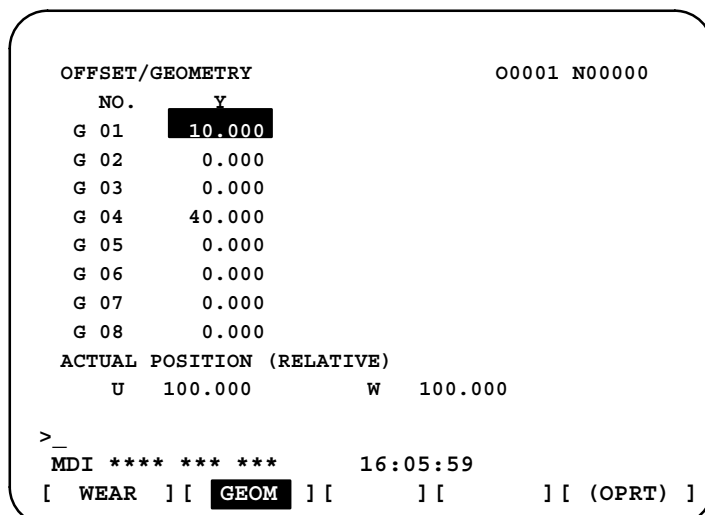

3-2 Press soft key **[WEAR]** to display the tool wear compensation values along the Y-axis.

```

OFFSET/WEAR                                00001 N00000
  NO.      Y
W 01      10.000
W 02       0.000
W 03       0.000
W 04      40.000
W 05       0.000
W 06       0.000
W 07       0.000
W 08       0.000
ACTUAL POSITION (RELATIVE)
  U 100.000      W 100.000
>_
MDI ***** ** 16:05:59
[ WEAR ] [ GEOM ] [      ] [ (OPRT) ]

```

- 4 Position the cursor at the offset number to be changed by using either of the following methods:
 - Move the cursor to the offset number to be changed using page keys and cursor keys.
 - Type the offset number and press soft key **[NO.SRH]**.
- 5 Type the offset value.
- 6 Press soft key **[WEAR]**. The offset value is set and displayed.

```

OFFSET/WEAR                                00001 N00000
  NO.      Y
W 01      10.000
W 02       0.000
W 03       0.000
W 04      40.000
W 05       0.000
W 06       0.000
W 07       0.000
W 08       0.000
ACTUAL POSITION (RELATIVE)
  U 100.000      W 100.000
>_
MDI ***** ** 16:05:59
[ NO.SRH ] [ MEASUR ] [ INP.C. ] [ +INPUT ] [ INPUT ]

```

Procedure for counter input of the offset value

To set relative coordinates along the Y-axis as offset values:

- 1 Move the reference tool to the reference point.
- 2 Reset relative coordinate Y to 0 (see subsec. III-11.1.2).
- 3 Move the tool for which offset values are to be set to the reference point.
- 4 Move the cursor to the value for the offset number to be set, press , then press soft key **[INP.C.]**.

Relative coordinate Y (or V) is now set as the offset value.

11.4.7 Displaying and Entering Setting Data



Data such as the TV check flag and punch code is set on the setting data screen. On this screen, the operator can also enable/disable parameter writing, enable/disable the automatic insertion of sequence numbers in program editing, and perform settings for the sequence number comparison and stop function.

See Chapter III-10 for automatic insertion of sequence numbers.

See subsection III-11.4.8 for the sequence number comparison and stop function. This subsection describes how to set data.

Procedure for setting the setting data

- 1 Select the **MDI** mode.
- 2 Press function key .
- 3 Press soft key **[SETTING]** to display the setting data screen. This screen consists of several pages.

Press page key  or  until the desired screen is displayed.

An example of the setting data screen is shown below.

```

SETTING (HANDY)                                00001 N00000

PARAMETER WRITE = 1 (0:DISABLE 1:ENABLE)
TV CHECK =      0 (0:OFF   1:ON)
PUNCH CODE =    1 (0:EIA   1:ISO)
INPUT UNIT =    0 (0:MM    1:INCH)
I/O CHANNEL =   0 (0-3:CHANNEL NO.)
SEQUENCE NO. =  0 (0:OFF   1:ON)
TAPE FORMAT =   0 (0:NO CNV 1:F15)
SEQUENCE STOP = 0 (PROGRAM NO.)
SEQUENCE STOP = 0 (SEQUENCE NO.)

> _
MDI **** * 16:05:59
[ OFFSET ] [ SETTING ] [ WORK ] [ ] [ (OPRT) ]

```

```

SETTING (HANDY)                                00001 N00000

MIRROR IMAGE X = 0 (0:OFF   1:ON)
MIRROR IMAGE Z = 0 (0:OFF   1:ON)

> _
MDI **** * 16:05:59
[ OFFSET ] [ SETTING ] [ WORK ] [ ] [ (OPRT) ]



```

- 4 Move the cursor to the item to be changed by pressing cursor keys



- 5 Enter a new value and press soft key **[INPUT]**.



Contents of settings

- **PARAMETER WRITE** Setting whether parameter writing is enabled or disabled.
 0 : Disabled
 1 : Enabled
- **TV CHECK** Setting to perform TV check.
 0 : No TV check
 1 : Perform TV check
- **PUNCH CODE** Setting code when data is output through reader puncher interface.
 0 : EIA code output
 1 : ISO code output
- **INPUT UNIT** Setting a program input unit, inch or metric system
 0 : Metric
 1 : Inch
- **I/O CHANNEL** Using channel of reader/puncher interface.
 0 : Channel 0
 1 : Channel 1
 2 : Channel 2
 3 : Channel 3
- **SEQUENCE STOP** Setting of whether to perform automatic insertion of the sequence number or not at program edit in the EDIT mode.
 0 : Does not perform automatic sequence number insertion.
 1 : Perform automatic sequence number insertion.
- **TAPE FORMAT** Setting the F15 tape format conversion.
 0 : Tape format is not converted.
 1 : Tape format is converted.
 See PROGRAMMING for the F15 tape format.
- **SEQUENCE STOP** Setting the sequence number with which the operation stops for the sequence number comparison and stop function and the number of the program to which the sequence number belongs
- **MIRROR IMAGE** Setting of mirror image ON/OFF for each axes.
 0 : Mirror image off
 1 : Mirror image on
- **Others** Page key  or  can also be pressed to display the SETTING (TIMER) screen. See subsection III-11.4.9 for this screen.

11.4.8 Sequence Number Comparison and Stop

If a block containing a specified sequence number appears in the program being executed, operation enters single block mode after the block is executed.

Procedure for sequence number comparison and stop

- 1 Select the **MDI** mode.
- 2 Press function key  .
- 3 Press chapter selection soft key [**SETTING**].
- 4 Press page key  or  several times until the following screen is displayed.

```

SETTING (HANDY)                                00001 N00000

PARAMETER WRITE = 1 (0:DISABLE 1:ENABLE)
TV CHECK        = 0 (0:OFF   1:ON)
PUNCH CODE      = 1 (0:EIA   1:ISO)
INPUT UNIT      = 0 (0:MM    1:INCH)
I/O CHANNEL     = 0 (0-3:CHANNEL NO.)
SEQUENCE NO.    = 0 (0:OFF   1:ON)
TAPE FORMAT     = 0 (0:NO CNV 1:F10/11)
SEQUENCE STOP   = 0 (PROGRAM NO.)
SEQUENCE STOP   = 11(SEQUENCE NO.)

> _
MDI **** * * * * *      16:05:59
[ OFFSET ] [ SETTING ] [ WORK ] [      ] [ (OPRT) ]

```

- 5 Enter in (PROGRAM NO.) for SEQUENCE STOP the number (1 to 9999) of the program containing the sequence number with which operation stops.
- 6 Enter in (SEQUENCE NO.) for SEQUENCE STOP (with five or less digits) the sequence number with which operation is stopped.
- 7 When automatic operation is executed, operation enters single block mode at the block containing the sequence number which has been set.

Explanations

- **Sequence number after the program is executed**

After the specified sequence number is found during the execution of the program, the sequence number set for sequence number compensation and stop is decremented by one. When the power is turned on, the setting of the sequence number is 0.
- **Exceptional blocks**

If the predetermined sequence number is found in a block in which all commands are those to be processed within the CNC control unit, the execution does not stop at that block.

Example

```
N1 #1=1 ;  
N2 IF [#1 EQ 1] GOTO 08 ;  
N3 GOTO 09 ;  
N4 M98 P1000 ;  
N5 M99 ;
```

In the example shown above, if the predetermined sequence number is found, the execution of the program does not stop.
- **Stop in the canned cycle**

If the predetermined sequence number is found in a block which has a canned-cycle command, the execution of the program stops after the return operation is completed.
- **When the same sequence number is found several times in the program**

If the predetermined sequence number appears twice or more in a program, the execution of the program stops after the block in which the predetermined sequence number is found for the first time is executed.
- **Block to be repeated a specified number of times**



If the predetermined sequence number is found in a block which is to be executed repeatedly, the execution of the program stops after the block is executed specified times.

11.4.9 Displaying and Setting Run Time, Parts Count, and Time

Various run times, the total number of machined parts, number of parts required, and number of machined parts can be displayed. This data can be set by parameters or on this screen (except for the total number of machined parts and the time during which the power is on, which can be set only by parameters).

This screen can also display the clock time. The time can be set on the screen.

Procedure for Displaying and Setting Run Time, Parts Count and Time

- 1 Select the MDI mode.
- 2 Press function key  .
- 3 Press chapter selection soft key **[SETTING]**.
- 4 Press page key  or  several times until the following screen is displayed.

```

SETTING (TIMER)                                O0001 N00000

PARTS TOTAL      =      14
PARTS REQUIRED    =      0
PARTS COUNT      =      23

POWER ON         =      4H 31M
OPERATING TIME   =      0H 0M 0S
CUTTING TIME     =      0H 37M 5S
FREE PURPOSE     =      0H 0M 0S
CYCLE TIME       =      0H 0M 0S
DATE             =      2001/06/05
TIME             =      11:32:52

> _ S 0 T0000
MDI **** * 16:05:59
[ OFFSET ] [ SETTING ] [ WORK ] [ (OPRT) ]

```

- 5 To set the number of parts required, move the cursor to PARTS REQUIRED and enter the number of parts to be machined.
- 6 To set the clock, move the cursor to DATE or TIME, enter a new date or time, then press soft key **[INPUT]**.

Display items

- PARTS TOTAL

This value is incremented by one when M02, M30, or an M code specified by parameter 6710 is executed. This value cannot be set on this screen. Set the value in parameter 6712.

- PARTS REQUIRED

It is used for setting the number of machined parts required. When the "0" is set to it, there is no limitation to the number of parts. Also, its setting can be made by the parameter (No. 6713).

- **PARTS COUNT** This value is incremented by one when M02, M30, or an M code specified by parameter 6710 is executed. The value can also be set by parameter 6711. In general, this value is reset when it reaches the number of parts required. Refer to the manual issued by the machine tool builder for details.
- **POWER ON** Displays the total time which the power is on. This value cannot be set on this screen but can be preset in parameter 6750.
- **OPERATING TIME** Indicates the total run time during automatic operation, excluding the stop and feed hold time.
This value can be preset in parameter 6751 or 6752.
- **CUTTING TIME** Displays the total time taken by cutting that involves cutting feed such as linear interpolation (G01) and circular interpolation (G02 or G03). This value can be preset in parameter 6753 or 6754.
- **FREE PURPOSE** This value can be used, for example, as the total time during which coolant flows. Refer to the manual issued by the machine tool builder for details.
- **CYCLE TIME** Indicates the run time of one automatic operation, excluding the stop and feed hold time. This is automatically preset to 0 when a cycle start is performed at reset state. It is preset to 0 even when power is removed.
- **DATA and TIME** Displays the current date and time. The date and time can be set on this screen.

Explanations

- **Usage** When the command of M02 or M30 is executed, the total number of machined parts and the number of machined parts are incremented by one. Therefore, create the program so that M02 or M30 is executed every time the processing of one part is completed. Furthermore, if an M code set to the parameter (No. 6710) is executed, counting is made in the similar manner. Also, it is possible to disable counting even if M02 or M30 is executed (parameter PCM (No. 6700#0) is set to 1). For details, see the manual issued by machine tool builders.

Restrictions

- **Run time and part count settings** Negative value cannot be set. Also, the setting of “M” and “S” of run time is valid from 0 to 59.
Negative value may not be set to the total number of machined parts.
- **Time settings** Neither negative value nor the value exceeding the value in the following table can be set.

Item	Maximum value	Item	Maximum value
Year	2085	Hour	23
Month	12	Minute	59
Day	31	Second	59

11.4.10 Displaying and Setting the Workpiece Origin Offset Value

Displays the workpiece origin offset for each workpiece coordinate system (G54 to G59) and external workpiece origin offset. The workpiece origin offset and external workpiece origin offset can be set on this screen.

Procedure for Displaying and Setting the Workpiece Origin Offset Value

- 1 Press function key  .
- 2 Press chapter selection soft key **[WORK]**.
The workpiece coordinate system setting screen is displayed.

WORK COORDINATES		O0001 N00000	
NO.	DATA	NO.	DATA
00 X	0.000	02 X	152.580
(EXT) Z	0.000	(G55) Z	234.000
01 X	20.000	03 X	300.000
(G54) Z	50.000	(G56) Z	200.000
> _		S	0 T0000
MDI **** * * * *	16:05:59		
[OFFSET]	[SETING]	[WORK]	[] [(OPRT)]

- 3 The screen for displaying the workpiece origin offset values consists of two or more pages. Display a desired page in either of the following two ways:

Press the page up  or page down  key.

Enter the workpiece coordinate system number (0: external workpiece origin offset, 1 to 6: workpiece coordinate systems G54 to G59) and press operation selection soft key **[NO.SRH]**.

- 4 Turn off the data protection key to enable writing.
- 5 Move the cursor to the workpiece origin offset to be changed.
- 6 Enter a desired value by pressing numeric keys, then press soft key **[INPUT]**. The entered value is specified in the the workpiece origin offset value. Or, by entering a desired value with numeric keys and pressing soft key **[+INPUT]**, the entered value can be added to the previous offset value.
- 7 Repeat **5** and **6** to change other offset values.
- 8 Turn on the data protection key to disable writing.

11.4.11 Direct Input of Measured Workpiece Origin Offsets

This function is used to compensate for the difference between the programmed workpiece coordinate system and the actual workpiece coordinate system. The measured offset for the origin of the workpiece coordinate system can be input on the screen such that the command values match the actual dimensions.

Selecting the new coordinate system matches the programmed coordinate system with the actual coordinate system.

Procedure for Inputting of Measured Workpiece Origin Offsets

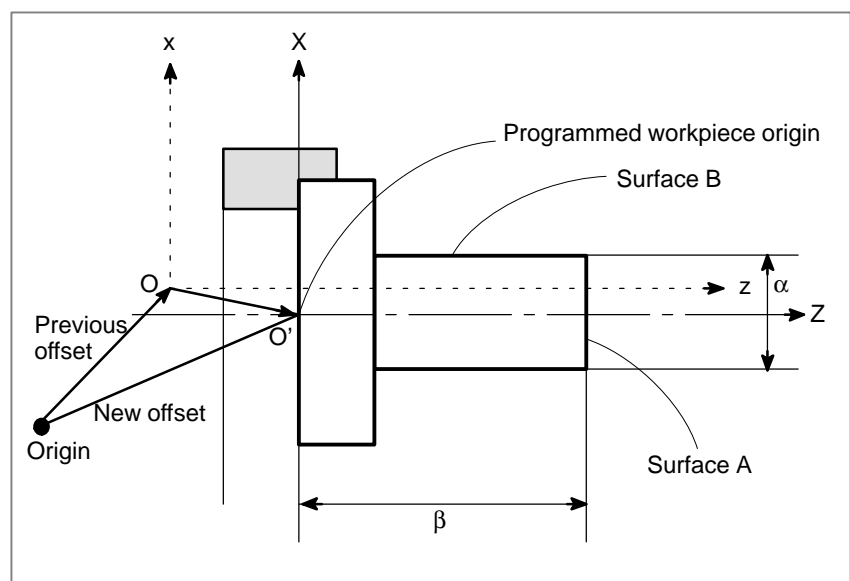

- 1 When the workpiece is shaped as shown above, cut surface A manually.
- 2 Move the tool along the X axis without changing the Z coordinate then stop the spindle.
- 3 Measure distance β between surface A and the programmed origin of the workpiece coordinate system as shown above.
- 4 Press function key  .

- 5 To display the workpiece origin offset setting screen, press the chapter selection soft key **[WORK]**.

```

WORK COORDINATES                                01234 N56789
(G54)

NO.      DATA      NO.      DATA
00 X 0.000      02 X 0.000
(EXT) Z 0.000      (G55) Z 0.000

01 X 0.000      03 X 0.000
(G54) Z 0.000      (G56) Z 0.000

> Z100.                                S 0 T0000
MDI **** * * * * * 16:05:59
[ NO.SRH ] [ MEASUR ] [      ] [ +INPUT ] [ INPUT ]

```

- 6 Position the cursor to the workpiece origin offset value to be set.
- 7 Press the address key for the axis along which the offset is to be set (Z-axis in this example).
- 8 Enter the measured value (α) then press the **[MEASUR]** soft key.
- 9 Cut surface B manually.
- 10 Move the tool along the Z axis without changing the X coordinate then stop the spindle.
- 11 Measure the diameter of surface A (α) then enter the diameter at X.

Restrictions



- **Consecutive input** Offsets for two or more axes cannot be input at the same time.
- **During program execution** This function cannot be used while a program is being executed.
- **Effect from other shift value** Any shift specified for the workpiece coordinate system or external offset remains effective when this function is used.

11.4.12 Displaying and Setting Custom Macro Common Variables



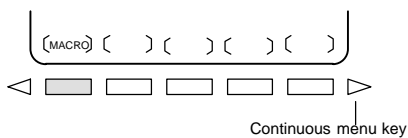





Displays common variables (#100 to #149 or #100 to #199, and #500 to #531 or #500 to #999) on the CRT. When the absolute value for a common variable exceeds 99999999, ***** is displayed. The values for variables can be set on this screen. Relative coordinates can also be set to variables.

Procedure for displaying and setting custom macro common variables



- 1 Press function key .
- 2 Press the continuous menu key , then press chapter selection soft key **[MACRO]**. The following screen is displayed:

VARIABLE		O0001 N00000	
NO.	DATA	NO.	DATA
100	1000.000	108	0.000
101	0.000	109	40000.000
102	-50000.000	110	153020.00
103	0.000	111	0001.000
104	1238501.0	112	0.000
105	0.000	113	20000.000
106	0.000	114	0.000
107	0.000	115	0.000
ACTUAL POSITION (RELATIVE)			
U0.000		W 0.000	
> _		S 0 T0000	
MDI **** * * * * *		16:05:59	
[NO.SRH] [] []		[INP.C.] [] [INPUT]	

- 3 Move the cursor to the variable number to set using either of the following methods:
 - Enter the variable number and press soft key **[NO.SRH]**.
 - Move the cursor to the variable number to set by pressing page keys  and/or  and cursor keys , , , and/or .
- 4 Enter data with numeric keys and press soft key **[INPUT]**.
- 5 To set a relative coordinate in a variable, press address key  or , then press soft key **[INP.C.]**.
- 6 To set a blank in a variable, just press soft key **[INPUT]**. The value field for the variable becomes blank.

11.4.13 Displaying and Setting the Software Operator's Panel

With this function, functions of the switches on the machine operator's panel can be controlled from the MDI panel.
Jog feed can be performed using numeric keys.



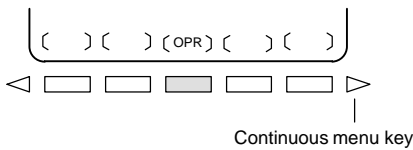

Procedure for displaying and setting the software operator's panel

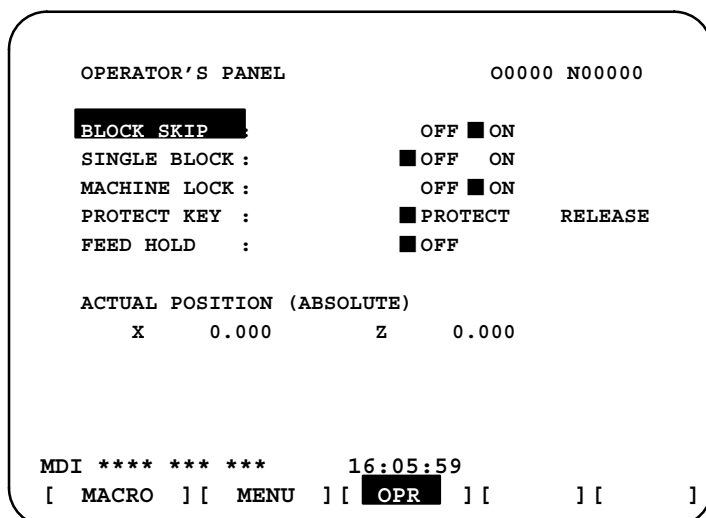
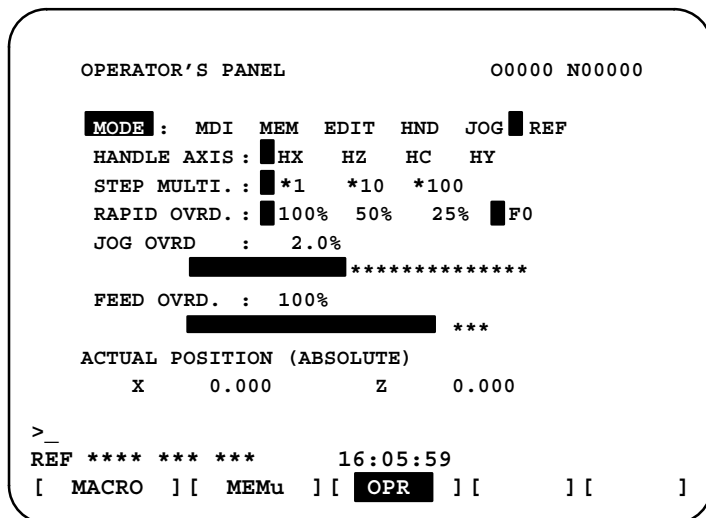

- 1 Press function key .
- 2 Press the continuous menu key , then press chapter selection soft key **[OPR]**.
- 3 The screen consists of several pages.
Press page key or until the desired screen is displayed.



- 4 Move the cursor to the desired switch by pressing cursor key or .

- 5 Push the cursor move key  or  to match the mark  to an arbitrary position and set the desired condition.
- 6 Press one of the following arrow keys to perform jog feed. Press the  key together with an arrow key to perform manual continuous rapid traverse.

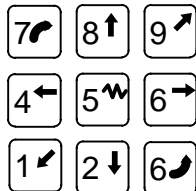

Explanations

- **Valid operations**

The valid operations on the software operator's panel are shown below. Whether to use the CRT or machine operator's panel for each group of operations can be selected by parameter 7200.

Group1 : Mode selection

Group2 : Selection of jog feed axis, manual continuous rapid traverse

Group3 : Selection of manual pulse generator feed axis, selection of manual pulse magnification x1, x10, x100

Group4 : Jog federate, federate override, rapid traverse override

Group5 : Optional block skip, single block, machine lock, dry run

Group6 : Protect key

Group7 : Feed hold

- **Display**

The groups for which the machine operator's panel is selected by parameter 7200 are not displayed on the software operator's panel.

- **Screens on which jog feed is valid**

When the CRT indicates other than the software operator's panel screen and diagnostic screen, jog feed is not conducted even if the arrow key is pushed.

- **Jog feed and arrow keys**

The feed axis and direction corresponding to the arrow keys can be set with parameters (Nos. 7210 to 7217).

- **General purpose switches**





Eight optionally definable switches are added as an extended function of the software operator's panel. The name of these switches can be set by parameters as character strings of max. 8 characters. For the meanings of these switches, refer to the manual issued by machine tool builder.

11.4.14 Displaying and Setting Tool Life Management Data

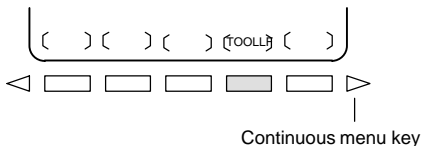
Tool life data can be displayed to inform the operator of the current state of tool life management. Groups which require tool changes are also displayed. The tool life counter for each group can be preset to an arbitrary value. Tool data (execution data) can be reset or cleared. To register or modify tool life management data, a program must be created and executed. See Explanations in this section for details.

Procedure for display and setting the tool life management data



- 1 Press function key .
- 2 Press the continuous menu key  to display chapter selection soft key **[TOOLLF]**.
- 3 Press soft key **[TOOLLF]**.
- 4 One page displays data on two groups. Pressing page key  or  successively displays data on the following groups. Up to four group Nos., for which the Tool Change signal is being issued, are displayed at the bottom of each page. An arrow shown in the figure is displayed for five or more groups, if exists.



```

TOOL LIFE DATA :                O3000 N00060
                               SELECTED GROUP 000
GROUP 001 : LIFE  0150  COUNT  0000
  0034 0078 0012 0056
  0090 0035 0026 0061
  0000 0000 0000 0000
  0000 0000 0000 0000

  GROUP 002 : LIFE  1400  COUNT  0000
  0062 0024 0044 0074
  0000 0000 0000 0000
  0000 0000 0000 0000
  0000 0000 0000 0000

  TO BE CHANGED : 003 004 005 006 ---->
> _
MEM **** * 16:05:59
[ MACRO ] [ ] [ OPR ] [ TOOLLF ] [ (OPRT) ]

```

- 5 To display the page containing the data for a group, enter the group number and press soft key **[NO.SRH]**. The cursor can be moved to an arbitrary group by pressing cursor key  or .
- 6 To change the value in the life counter for a group, move the cursor to the group, enter a new value (four digits), and press **[INPUT]**. The life counter for the group indicated by the cursor is preset to the entered value. Other data for the group is not changed.

- 7 To reset the tool data, move the cursor on the group to reset, then press the **[OPRT]**, **[CLEAR]**, and **[EXEC]** soft keys in this order. All execution data for the group indicated by the cursor is cleared together with the marks (@, #, or *).

Explanations

• Registering tool life management data

The tool life management data must be executed to register it in the CNC memory.

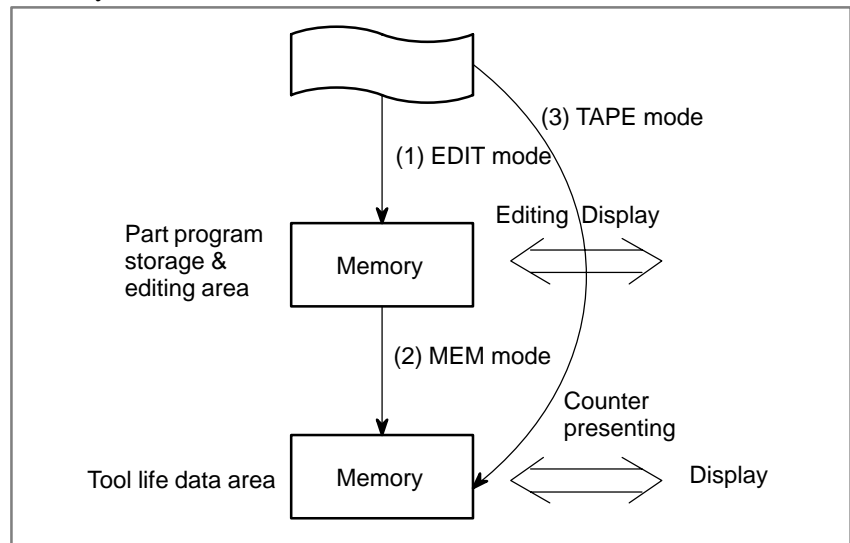

- (1) Load the program for tool life management in the EDIT mode, as with an ordinary CNC tape. The program will be registered in the part program memory and will be made ready for display and editing.
- (2) Perform a cycle start operation in the MEM mode to run the program. The data will be stored in the tool life data area of the memory; at the same time, the already existing tool life data of all groups will be cancelled and the life counters will be cleared. Data once stored is not erased by turning the power off.
- (3) Executing a cycle start operation in the TAPE mode instead of the operation of (1), stores the program contents directly onto the tool life data area. In this case, however, display and editing cannot be done as in (1). TAPE mode is not always prepared according to the machine tool builders.

- Display contents

```

TOOL LIFE DATA : O3000 N00060
                SELECTED GROUP 000
GROUP 001      : LIFE 0150 COUNT 0007
  *0034 #0078 @0012 0056
    0090 0035 0026 0061
    0000 0000 0000 0000
    0000 0000 0000 0000

GROUP 002      : LIFE 1400 COUNT 0000
  0062 0024 0044 0074
  0000 0000 0000 0000
  0000 0000 0000 0000
  0000 0000 0000 0000



TO BE CHANGED : 003 004 005 006 --->
> _
MEM **** *** *** 16:05:59
[ MACRO ][ ] [ OPR ][ TOOLLF ] [ (OPRT) ]

```

- The first line is the title line.
- In the second line the group number of the current command is displayed.
When there is no group number of the current command, 0 is displayed.
- In lines 3 to 7 the tool life data of the group is displayed.
The third line displays group number, life and the count used.
The life count is chosen by parameter LTM (No. 6800#2) as either minutes(or hours) or number of times used.
In lines 4 to 7, tool numbers are displayed. In this case, the tool is selected in the order, 0034 → 0078 → 0012 → 0056 → 0090 ...
The meaning of each mark before the tool numbers is:
* : Shows the life has finished.
: Shows that the skip command has been accepted.
@ : Shows that the tool is currently being used.
The life counter counts for tool with @.
“*” is displayed when the next command is issued by the group to which it belongs.
- Lines 8 to 12 are next group life data to the group displayed in lines 3 to 7.
- In the thirteenth line the group number when the tool change signal is being emitted is displayed. The group number display appears in ascending order. When it cannot be completely displayed, “—>” is displayed.

11.4.15 Setting and Displaying B-axis Tool Compensation

Setting and displaying B-axis tool compensation

- 1 Press the  function key.
- 2 Press the  continuous menu key several times. Then, press the **[OFST.B]** chapter selection key.
 - When the option for tool geometry and wear compensation is not provided,

OFFSET (B-AXIS)		O0200 N00000
No.	DATA	
51	-999.999	
52	-999.999	
53	-999.999	
54	-999.999	
55	-999.999	
56	-999.999	
57	-999.999	
58	-999.999	
59	-999.999	

>_ MDI **** * S 0 T0000
15:29:51
[**OFST.B**] [] [] [] [] [] []

- When the option for tool geometry and wear compensation is provided,

OFFSET (B-AXIS)			O0200 N00000
NO.	(WEAR)	(GEOMETRY)	
51	-999.999	-999.999	
52	-999.999	-999.999	
53	-999.999	-999.999	
54	-999.999	-999.999	
55	-999.999	-999.999	
56	-999.999	-999.999	
57	-999.999	-999.999	
58	-999.999	-999.999	
59	-999.999	-999.999	

>_ MDI **** * S 0 T0000
15:29:51
[**OFST.B**] [] [] [] [] [] []

- 3 Position the cursor to the item to be set or modified, using the cursor keys.

- 4 Enter the value, then press the  key.

Explanations

The offset can be set to a value in the following valid data ranges.

Offset	Metric input	Inch input
IS-B	-999.999 to 999.999	-99.9999 to 99.9999
IS-C	-999.9999 to 999.9999	-99.99999 to 99.99999

Special B-axis offsets are input or output together with usual offsets. When the option for tool geometry and wear compensation is provided, wear offsets and geometry offsets can be specified separately. A tool offset consists of both the specified wear offset and geometry offset. In two-path control, tool offsets can be specified for each tool post or both tool posts, depending on the setting of COF, bit 0 of parameter No. 8242.

11.5 SCREENS DISPLAYED BY FUNCTION KEY

When the CNC and machine are connected, parameters must be set to determine the specifications and functions of the machine in order to fully utilize the characteristics of the servo motor or other parts.

This chapter describes how to set parameters on the MDI panel. Parameters can also be set with external input/output devices such as the Handy File (see Chapter III-9).

In addition, pitch error compensation data used for improving the precision in positioning with the ball screw on the machine can be set or displayed by the operations under function key  .

See Chapter III-7 for the diagnostic screens displayed by pressing function key  .

11.5.1 Displaying and Setting Parameters







When the CNC and machine are connected, parameters are set to determine the specifications and functions of the machine in order to fully utilize the characteristics of the servo motor. The setting of parameters depends on the machine. Refer to the parameter list prepared by the machine tool builder.

Normally, the user need not change parameter setting.

Procedure for displaying and setting parameters

- 1 Set 1 for **PARAMETER WRITE** to enable writing. See the procedure for enabling/disabling parameter writing described below.
- 2 Press function key  .
- 3 Press chapter selection soft key **[PARAM]** to display the parameter screen.

PARAMETER (SETTING)		00010 N00002						
0000	SEQ	INI	ISO	TVC				
	0 0 0 0 0 0 0							
0001			FCV					
	0 0 0 0 0 0 0							0
0012								MIR
X	0 0 0 0 0 0 0							0
Y	0 0 0 0 0 0 0							0
Z	0 0 0 0 0 0 0							0
0020	I/O CHANNEL							0
0022								0
> _								
MDI **** * * * * *		16:05:59						
[PARAM] [DGNOS] [PMC] [SYSTEM] [(OPRT)]								

- 4 Move the cursor to the parameter number to be set or displayed in either of the following ways:
 - Enter the parameter number and press soft key **[NO.SRH]** .
 - Move the cursor to the parameter number using the page keys,  and  , and cursor keys,  ,  ,  , and  .
- 5 To set the parameter, enter a new value with numeric keys and press soft key **[INPUT]** in the MDI mode. The parameter is set to the entered value and the value is displayed.
- 6 Set 0 for **PARAMETER WRITE** to disable writing.

Procedure for enabling/displaying parameter writing

- 1 Select the **MDI** mode or enter state emergency stop.
- 2 Press function key  .
- 3 Press soft key [**SETTING**] to display the setting screen.

```

SETTING (HANDY)                                00001 N00000

PARAMETER WRITE = 1 (0:DISABLE 1:ENABLE)
TV CHECK        = 0 (0:OFF 1:ON)
PUNCH CODE      = 1 (0:EIA 1:ISO)
INPUT UNIT      = 0 (0:MM 1:INCH)
I/O CHANNEL     = 0 (0-3:CHANNEL NO.)
SEQUENCE NO.    = 0 (0:OFF 1:ON)
TAPE FORMAT     = 0 (0:NO CNV 1:F10/11)
SEQUENCE STOP   = 0 (PROGRAM NO.)
SEQUENCE STOP   = 11 (SEQUENCE NO.)

> _ S 0 T0000
MDI **** * 16:05:59
[ OFFSET ] [ SETING ] [ WORK ] [ (OPRT) ]

```

- 4 Move the cursor to **PARAMETER WRITE** using cursor keys.
- 5 Press soft key **[(OPRT)]**, then press **[1: ON]** to enable parameter writing.
At this time, the CNC enters the P/S alarm state (No. 100).
- 6 After setting parameters, return to the setting screen. Move the cursor to **PARAMETER WRITE** and press soft key **[(OPRT)]** , then press **[0: OFF]**.
- 7 Depress the  key to release the alarm condition. If P/S alarm No. 000 has occurred, however, turn off the power supply and then turn it on, otherwise the P/S alarm is not released.

Explanations

- **Setting parameters with external input/output devices**
See Chapter 8 for setting parameters with external input/output devices such as the Handy File.
- **Parameters that require turning off the power**
Some parameters are not effective until the power is turned off and on again after they are set. Setting such parameters causes alarm 000. In this case, turn off the power, then turn it on again.
- **Parameter list**
Refer to the FANUC Series 16i/18i/160i/180i-MODEL A Parameter Manual (B-63010EN) for the parameter list.
- **Setting data**
Some parameters can be set on the setting screen if the parameter list indicates “Setting entry is acceptable”. Setting 1 for **PARAMETER WRITE** is not necessary when three parameters are set on the setting screen.

11.5.2 Displaying and Setting Pitch Error Compensation Data

If pitch error compensation data is specified, pitch errors of each axis can be compensated in detection unit per axis.

Pitch error compensation data is set for each compensation point at the intervals specified for each axis. The origin of compensation is the reference position to which the tool is returned.

The pitch error compensation data is set according to the characteristics of the machine connected to the NC. The content of this data varies according to the machine model. If it is changed, the machine accuracy is reduced.

In principle, the end user must not alter this data.

Pitch error compensation data can be set with external devices such as the Handy File (see Chapter III-9). Compensation data can also be written directly with the MDI panel.

The following parameters must be set for pitch error compensation. Set the pitch error compensation value for each pitch error compensation point number set by these parameters.

In the following example, 33 is set for the pitch error compensation point at the reference position.

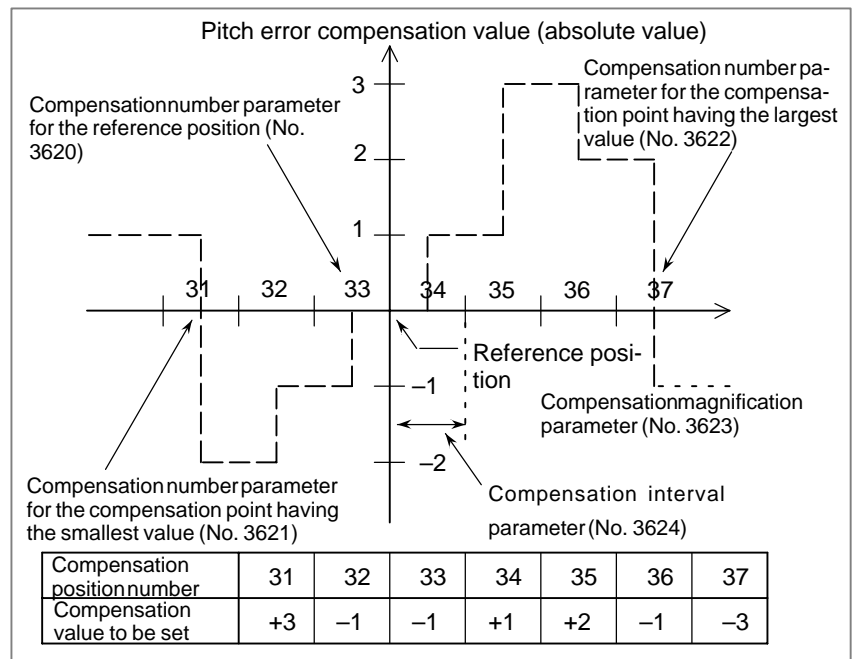

- Number of the pitch error compensation point at the reference position (for each axis): Parameter 3620
- Number of the pitch error compensation point having the smallest value (for each axis): Parameter 3621
- Number of the pitch error compensation point having the largest value (for each axis): Parameter 3622
- Pitch error compensation magnification (for each axis): Parameter 3623
- Interval of the pitch error compensation points (for each axis): Parameter 3624
- Travel distance per revolution of pitch error compensation of the rotary axis type (for each axis): Parameter 3625

Bidirectional pitch error compensation

The bidirectional pitch error compensation function allows independent pitch error compensation in different travel directions. (When the movement is reversed, compensation is automatically carried out as in a backlash.)

To use this function, specify pitch error compensation for each travel direction, that is, separately for the positive and negative directions of a movement.

When using bidirectional pitch error compensation (setting the BDP bit (bit 0 of parameter 3605) to 1), specify the following parameters in addition to the pitch error compensation parameter.

- Number of the pitch error compensation point at the negative end (for travel in the positive direction, for each axis): Parameter 3620
- Number of the pitch error compensation point at the positive end (for travel in the positive direction, for each axis): Parameter 3621
- Number of the pitch error compensation point at the negative end (for travel in the negative direction, for each axis): Parameter 3626
- Number of the pitch error compensation point at the positive end (for travel in the negative direction, for each axis): Parameter 3627

Procedure for displaying and setting the pitch error compensation data



1 Set the following parameters:

- Number of the pitch error compensation point at the reference position (for each axis): Parameter 3620
- Number of the pitch error compensation point having the smallest value (for each axis): Parameter 3621
- Number of the pitch error compensation point having the largest value (for each axis): Parameter 3622
- Pitch error compensation magnification (for each axis): Parameter 3623
- Interval of the pitch error compensation points (for each axis): Parameter 3624
- Travel distance per revolution of pitch error compensation of the rotary axis type (for each axis): Parameter 3625



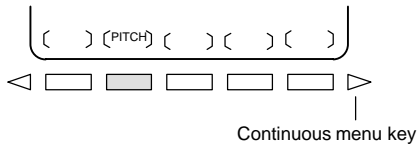



When using bidirectional pitch error compensation (setting the BDP bit (bit 0 of parameter 3605) to 1), specify the following parameters in addition to the pitch error compensation parameter.

- Number of the pitch error compensation point at the negative end (for travel in the positive direction, for each axis): Parameter 3620
- Number of the pitch error compensation point at the positive end (for travel in the positive direction, for each axis): Parameter 3621
- Number of the pitch error compensation point at the negative end (for travel in the negative direction, for each axis): Parameter 3626
- Number of the pitch error compensation point at the positive end (for travel in the negative direction, for each axis): Parameter 3627



- 2 Press function key  .
- 3 Press the continuous menu key , then press chapter selection soft key **[PITCH]**.
The following screen is displayed:

PIT-ERROR SETTING		00000 N00000
NO. DATA	NO. DATA	NO. DATA
0000 0	0010 0	0020 0
0001 0	0011 0	0021 0
0002 0	0012 0	0022 0
0003 0	0013 0	0023 0
(X) 0004 0	0014 0	0024 0
0005 0	0015 0	0025 0
0006 0	0016 0	0026 0
0007 0	0017 0	0027 0
0008 0	0018 0	0028 0
0009 0	0019 0	0029 0
> _		
MEM **** * * * * *		16:05:59
[NO.SRH] [ON:1] [OFF:0] [+INPUT] [-INPUT]		

- 4 Move the cursor to the compensation point number to be set in either of the following ways:
 - Enter the compensation point number and press the [NO.SRH] soft key.
 - Move the cursor to the compensation point number using the page keys,  and , and cursor keys, , , , and .
- 5 Enter a value with numeric keys and press the **[INPUT]** soft key.

11.6 DISPLAYING THE PROGRAM NUMBER, SEQUENCE NUMBER, AND STATUS, AND WARNING MESSAGES FOR DATA SETTING OR INPUT/OUTPUT OPERATION

The program number, sequence number, and current CNC status are always displayed on the screen except when the power is turned on, a system alarm occurs, or the PMC screen is displayed.

If data setting or the input/output operation is incorrect, the CNC does not accept the operation and displays a warning message.

This section describes the display of the program number, sequence number, and status, and warning messages displayed for incorrect data setting or input/output operation.

11.6.1 Displaying the Program Number and Sequence Number

The program number and sequence number are displayed at the top right on the screen as shown below.

The screenshot shows a CNC program editor screen. At the top right, the program number 'O2000' and sequence number 'N00130' are displayed. The program text is as follows:

```
PROGRAM
O1000
N100 G50 X0 Z0. ;
N101 G00 X100. Z50. ;;
N102 G01 X230. Z56. ;
N103 W-10. ;
N104 U-120. ;
N105 M02 ;

> _
EDIT **** * 16:05:59
[ PRGRM ] [ CHECK ] [ CURRNT ] [ NEXT ] [ (OPRT) ]
```

Annotations on the right side of the screen indicate that 'O2000' is the Program No. and 'N00130' is the Sequence No.

The program number and sequence number displayed depend on the screen and are given below:

On the program screen in the EDIT mode on Background edit screen:
The program No. being edited and the sequence number just prior to the cursor are indicated.

Other than above screens :

The program No. and the sequence No. executed last are indicated.

Immediately after program number search or sequence number search :

Immediately after the program No. search and sequence No. search, the program No. and the sequence No. searched are indicated.

11.6.2 Displaying the Status and Warning for Data Setting or Input/Output Operation

The current mode, automatic operation state, alarm state, and program editing state are displayed on the next to last line on the CRT screen allowing the operator to readily understand the operation condition of the system.

If data setting or the input/output operation is incorrect, the CNC does not accept the operation and a warning message is displayed on the next to last line of the CRT screen. This prevents invalid data setting and input/output errors.

Explanations

- Description of each display

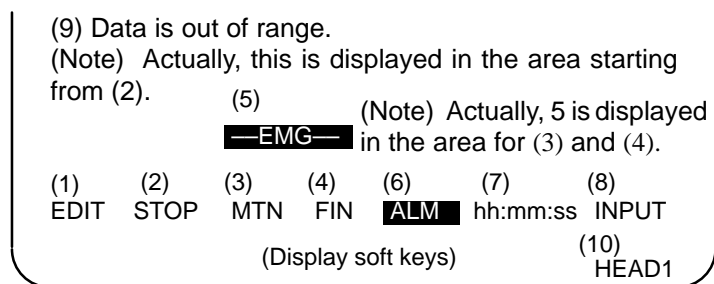

Note) Actually, (10) is displayed at the position where (8) is now displayed.

(1) Current mode

MDI : Manual data input, MDI operation
MEM : Automatic operation (Memory operation)
RMT : Automatic operation (DNC operation)
EDIT : Memory editing
HND : Manual handle feed
JOG : Jog feed
TJOG : TEACH IN JOG
THND : TEACH IN HANDLE
INC : Manual incremental feed
REF : Manual reference position return

(2) Automatic operation status

**** : Reset (When the power is turned on or the state in which program execution has terminated and automatic operation has terminated.)
STOP : Automatic operation stop (The state in which one block has been executed and automatic operation is stopped.)
HOLD : Feed hold (The state in which execution of one block has been interrupted and automatic operation is stopped.)
STRT : Automatic operation start-up (The state in which the system operates automatically)

(3) Axis moving status/dwell status

MTN : Indicates that the axis is moving.
DWL : Indicates the dwell state.
*** : Indicates a state other than the above.

(4) State in which an auxiliary function is being executed

FIN : Indicates the state in which an auxiliary function is being executed. (Waiting for the complete signal from the PMC)
*** : Indicates a state other than the above.

(5) Emergency stop or reset status

—EMG— : Indicates emergency stop.(Blinks in reversed display.)
—RESET— : Indicates that the reset signal is being received.

- (6) Alarm status**
- ALM** : Indicates that an alarm is issued. (Blinks in reversed display.)
BAT : Indicates that the battery is low. (Blinks in reversed display.)
Space : Indicates a state other than the above.
- (7) Current time** hh:mm:ss – Hours, minutes, and seconds
- (8) Program editing status**
- INPUT : Indicates that data is being input.
OUTPUT : Indicates that data is being output.
SRCH : Indicates that a search is being performed.
EDIT : Indicates that another editing operation is being performed
(insertion, modification, etc.)
LSK : Indicates that labels are skipped when data is input.
RSTR : Indicates that the program is being restarted
Space : Indicates that no editing operation is being performed.
- (9) Warning for data setting or input/output operation**
- When invalid data is entered (wrong format, value out of range, etc.), when input is disabled (wrong mode, write disabled, etc.), or when input/output operation is incorrect (wrong mode, etc.), a warning message is displayed. In this case, the CNC does not accept the setting or input/output operation.
The following are examples of warning messages:
- Example 1)**
When a parameter is entered
- ```
> 1
EDIT WRONG MODE

(Display soft keys)
```
- Example 2)**  
When a parameter is entered
- ```
> 999999999
MDI  TOO MANY DIGITS

(Display soft keys)
```
- Example 3)**
When a parameter is output to an external input/output device
- ```
> _
MEM WRONG MODE

(Display soft keys)
```
- (10) Tool post name (for the two-path control)**
- HEAD1 : Tool post 1 is selected.  
HEAD2 : Tool post 2 is selected.  
Other names can be used depending on the settings of parameters 3141 to 3147.  
The tool post name is displayed at the position where (8) is now displayed. While the program is edited, (8) is displayed.

## 11.7 SCREENS DISPLAYED BY FUNCTION KEY



By pressing the MESSAGE function key, data such as alarms, alarm history data, and external messages can be displayed. For information relating to alarm display, see Section III.7.1. For information relating to alarm history display, see Section III.7.2. For information relating to external message display, see the relevant manual supplied by the machine tool builder.

### 11.7.1 External Operator Message History Display

External operator messages can be preserved as history data. Preserved history data can be displayed on the external operator message history screen.

#### Procedure for external operator message history display

#### Procedure

- 1 Press the function key.
- 2 Press the continuous menu key , then press the chapter selection soft key **[MSGHIS]**. The screen shown below appears.

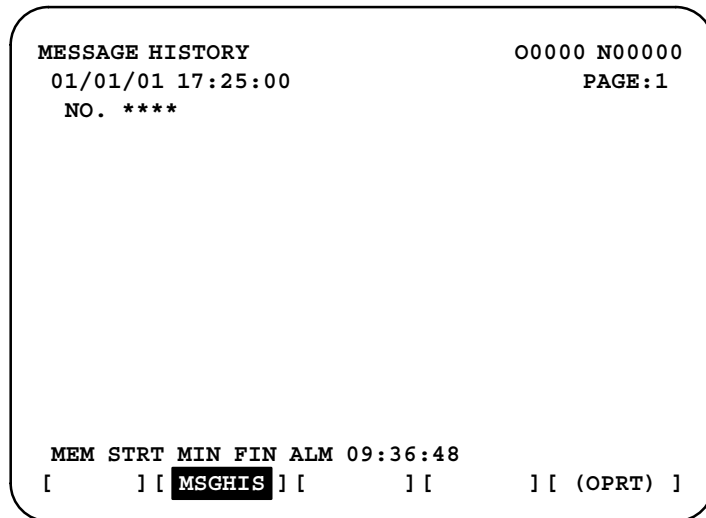
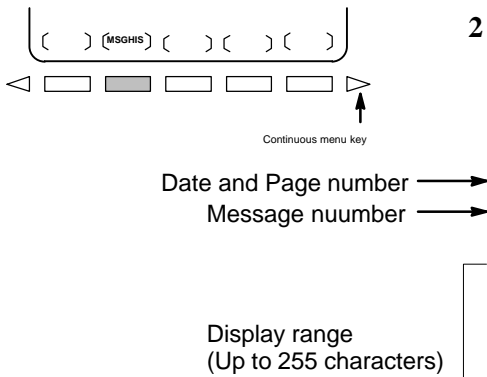

#### NOTE

Up to 255 characters can be specified for an external operator message. By setting MS1 and MS0 (bits 7 and 6 of parameter No. 3113), however, the number of characters that can be preserved as external operator message history data can be restricted, and the number of history data items selected.

## Explanations

- **Updating external operator message history data**

When an external operator message number is specified, updating of the external operator message history data is started; this updating is continued until a new external operator message number is specified or deletion of the external operator message history data is specified.
- **Clearing external operator message history data**

To clear external operator message history data, press the [CLEAR] soft key. This clears all external operator message history data. (Set MSGCR (bit 0 of parameter No. 3113) to 1.)  
Note that when MS1 and MS0 (bits 7 and 6 of parameter No. 3113), used to specify the number of external operator message history data items to be displayed, are changed, all existing external operator message history data is cleared.

## Limitations

- **Two-path control**

When two-path control is exercised, the external operator messages for system 1 are displayed. (The external operator messages for system 2 are not displayed.)
- **Option**

Before this function can be used, the external data input function or optional external message function must be selected.

## 11.8 CLEARING THE SCREEN

When screen indication isn't necessary, the life of the back light for LCD can be put off by turning off the back light.

The screen can be cleared by pressing specific keys. It is also possible to specify the automatic clearing of the screen if no keys are pressed during a period specified with a parameter.

But, the life of the back light may be contracted all the more when the clearing of screen and re-indication of screen are repeated beyond the necessity. This effect can be expected when a screen is cleared for more than one hour.

---

### 11.8.1 Erase CRT Screen Display

Holding down the  key and pressing an arbitrary function key clears the screen.



---

#### Procedure for Erase CRT Screen Display

---

#### Procedure

- Clearing the screen

Hold down the  key and press an arbitrary function key (such as  and  ).

- Restoring the screen

Press an arbitrary function key.

## 11.8.2 Automatic Erase CNC Screen Display

The CNC screen is automatically cleared if no keys are pressed during the period (in minutes) specified with a parameter. The screen is restored by pressing any key.

### Procedure for Automatic Erase CRT Screen Display

- **Clearing the screen**

The CNC screen is cleared once the period (minutes) specified with parameter No. 3123 has elapsed, provided the following conditions are satisfied:

#### Conditions for clearing the CNC screen

- Parameter No. 3123 is set to other than 0.
- None of the following keys have been pressed:
  - MDI keys
  - Soft keys
  - External input keys
- No alarm has been issued.

- **Restoring the screen**

The cleared CNC screen is restored once at least one of the following conditions is satisfied:

#### Conditions for restoring the CNC screen

- Any of the following keys has been pressed:
  - MDI keys
  - Soft keys
  - Externally input keys
- An alarm has been issued.

Some machines feature a special key for restoring the screen. For an explanation of the location and use of this key, refer to the corresponding manual, supplied by the machine tool builder.

### Explanations



- **Clearing the screen using  + function key**
- **Specified period**
- **Alarm for another path**

If parameter No. 3123 is set to 0, clearing of the screen using the  key and a function key (III-11.8.1) is disabled.

The period specified with parameter No. 3123 is valid only for tool post 1.

The screen is not cleared if an alarm is issued for tool post 1 or 2 or the loader before the specified period elapses.

#### CAUTION

Pressing any key while the screen is being cleared restores the screen. In such a case, however, the function assigned to the pressed key is initiated. Do not press the , , or  key to restore the screen, therefore.

# 12

## GRAPHICS FUNCTION



The graphic function indicates how the tool moves during automatic operation or manual operation.

## 12.1 GRAPHICS DISPLAY

It is possible to draw the programmed tool path on the screen, which makes it possible to check the progress of machining, while observing the path on the screen.

In addition, it is also possible to enlarge/reduce the screen.

The drawing coordinates (parameter) and graphic parameters must be set before a tool path can be displayed.

With two-path control, the tool paths of two tool posts are displayed on the same screen, one on the right and the other on the left.

### Graphics display procedure

#### Procedure

Set the drawing coordinates with parameter No. 6510 before starting drawing. See “Drawing Coordinate System” for the settings and corresponding coordinates.

For the two-path control, parameter GRL (bit 0 of No. 6500) specifies which tool post is displayed on which side (tool post 1 on the right or tool post 2 on the right).

- 1 Press function key . Press  for a small MDI unit.

The graphic parameter screen shown below appears. (If this screen does not appear, press soft key **[G.PRM]**.)

| GRAPHIC PARAMETER |          | O0001 N00020                  |
|-------------------|----------|-------------------------------|
| WORK LENGTH       | W=       | <b>130000</b>                 |
| WORK DIAMETER     | D=       | 130000                        |
| PROGRAM STOP      | N=       | 0                             |
| AUTO ERASE        | A=       | 1                             |
| LIMIT             | L=       | 0                             |
| GRAPHIC CENTER    | X=       | 61655                         |
|                   | Z=       | 90711                         |
| SCALE             | S=       | 32                            |
| GRAPHIC MODE      | M=       | 0                             |
|                   | S        | 0 T0000                       |
| >_                |          |                               |
| MEM STRT          | **** FIN | 12:12:24 HEAD1                |
| <b>[ G.PRM ]</b>  | [ ]      | [ GRAPH ] [ ZOOM ] [ (OPRT) ] |

- 2 For the two-path control, determine for which tool post the data is specified, using a tool post select signal.  
Specify the PROGRAM STOP (N), AUTO ERASE (A), and GRAPHIC CENTER (X,Y) parameters separately for each tool post. The other parameters are common to both tool posts. It does not matter for which tool post they are specified first.
- 3 Move the cursor with the cursor keys to a parameter to set.
- 4 Enter data, then press the  key.
- 5 Repeat steps 3 and 4 until all required parameters are specified.
- 6 Press soft key **[GRAPH]**.
- 7 Automatic or manual operation is started and machine movement is drawn on the screen.



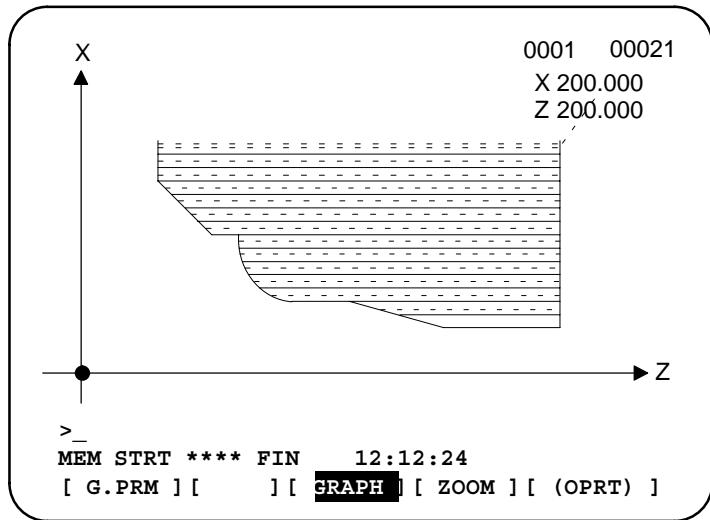

One-path lathe control

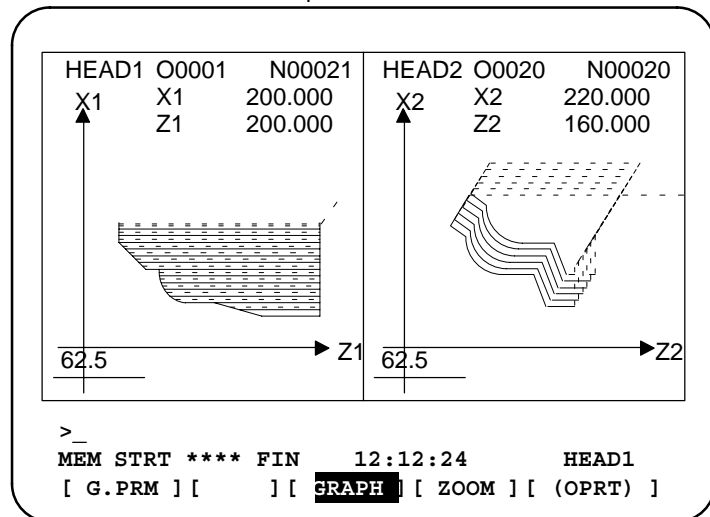

Two-path lathe control

● **Magnifying drawings**



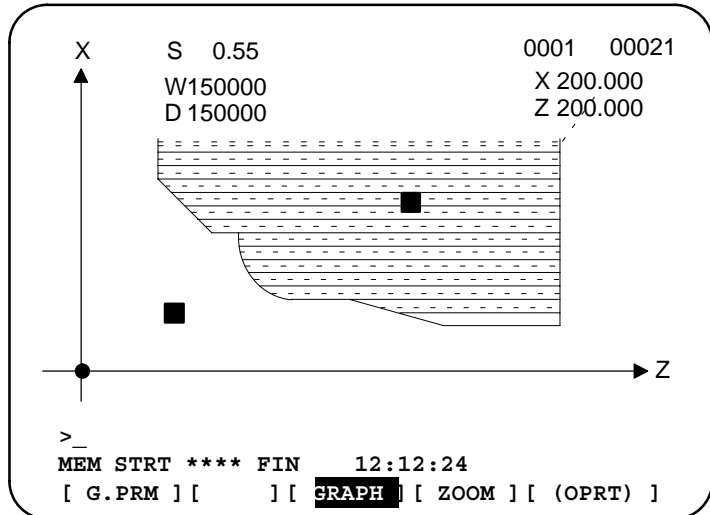

Part of a drawing on the screen can be magnified.

- 8 Press the  function key, then the **[ZOOM]** soft key to display a magnified drawing. The magnified-drawing screen contains two zoom cursors (■)



A rectangle that has one of its diagonals defined by the two zoom cursors is magnified to the full size of the screen.

For the two-path control, the zoom cursors are indicated for the selected tool post. Use the tool post select switch to select the tool post corresponding to the drawing to be magnified.

- 9 Using the cursor keys    , move the zoom cursors to specify a diagonal for the new screen. Pressing the **[HI / LO]** soft key toggles the zoom cursor to be moved.
- 10 To make the original drawing disappear, press **[EXEC]**.
- 11 Resume the previous operation. The part of the drawing specified with the zoom cursors will be magnified.

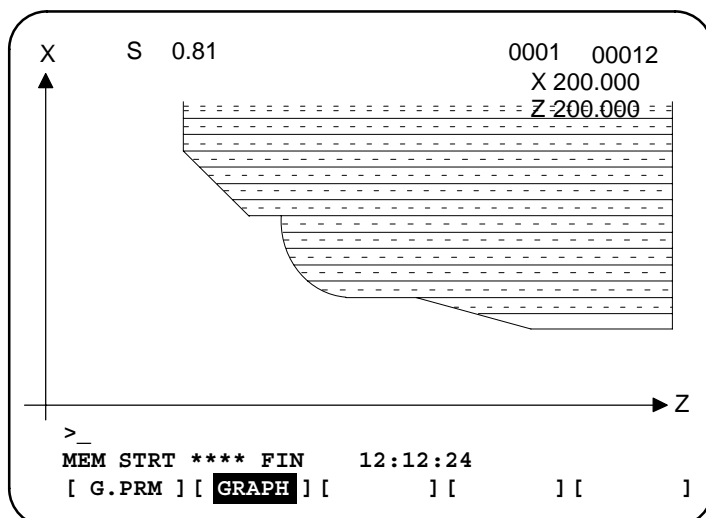

- 12 To display the original drawing, press the **[NORMAL]** soft key, then start automatic operation.

**Explanation**

• **Setting drawing coordinate systems**

Parameter No. 6510 is used to set a drawing coordinate system for using the graphic function. The relationships between setting values and drawing coordinate systems are indicated below. With two-path control, a different drawing coordinate system can be selected for each tool post.

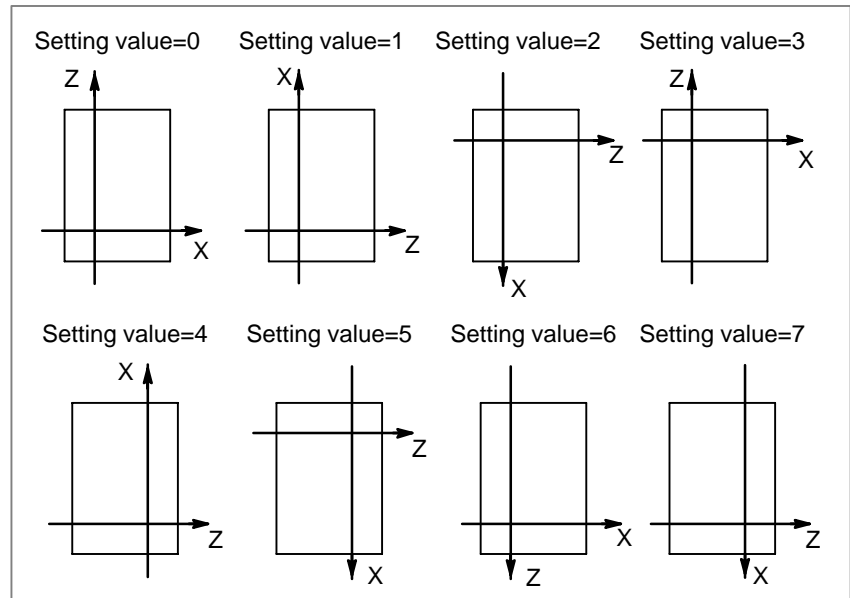

• **Graphics parameter**

**WORK LENGTH (W), WORK DIAMETER (D)**

Specify work length and work diameter. The table below lists the input unit and valid data range.

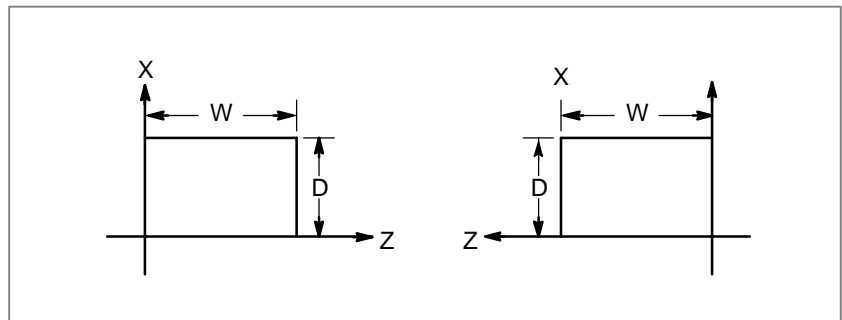

**Table 12.1 Unit and Range of Drawing Data**

| Increment system | Unit      |              | Valid range   |
|------------------|-----------|--------------|---------------|
|                  | mm input  | Inch input   |               |
| IS-B             | 0.001 mm  | 0.0001 inch  | 0 to 99999999 |
| IS-C             | 0.0001 mm | 0,00001 inch |               |

**GRAPHIC CENTER (X, Z), SCALE (S)**

A screen center coordinate and drawing scale are displayed. A scale screen center coordinate are automatically calculated so that a figure set in WORK LENGTH (a) and WORK DIAMETER (b) can be fully displayed on the screen. So, the user need not set these parameters usually.

A screen center coordinate is defined in the workpiece coordinate system. Table 12. 3. 2 indicates the unit and range. The unit of SCALE is 0.001%.

**PROGRAM STOP (N)**

Set the sequence number of an end block when part of the program is to be drawn. A value set in this parameter is automatically cancelled (cleared to -1) once a drawing is provided.

**AUTO ERASE (A)**

If 1 is set, the previous drawing is automatically erased when automatic operation is started from the reset state. Then, drawing is started.

**LIMIT (L)**

If 1 is set, the area of stored stroke limit 1 is drawn with double-dot-and-dash lines.

**DRAWING MODE (M)**

Drawing mode is used for dynamic graphic display (supported for the Super CAPi T). Usually, it does not need to be set.

**NOTE**

The parameter values for drawing are preserved even if power is turned off.

- **Executing drawing only**
- **Deleting the previous drawing**
- **Drawing a part of a program**
- **Drawing using dashed lines and solid lines**
- **Displaying coordinates**
- **Displaying the machine zero point**

Since the graphic drawing is done when coordinate value is renewed during automatic operation, etc., it is necessary to start the program by automatic operation. To execute drawing without moving the machine, therefore, enter the machine lock state.

Pressing the **[REVIEW]** soft key on the graphic screen deletes tool paths on it. Setting the graphic parameter as AUTO ERASE (A) = 1 specifies that when automatic operation is started at reset, program execution begins after the previous drawing is erased automatically (AUTO ERASE = 1).

When necessary to display a part of a program, search the starting block to be drawn by the sequence number search, and set the sequence number of the end block to the PROGRAM STOP N= of the graphic parameter before starting the program under cycle operation mode.

The tool path is shown with a dashed line (- - - -) for rapid traverse and with a solid line (—) for cutting feed.

The displayed drawing is indicated with coordinates in a work coordinate system.

The machine zero point is indicated with  mark.

- **Switching from a drawing screen to another screen**
- **Drawing for tool posts 1 and 2 (two-path lathe control)**

Even if the screen is switched to a non-drawing screen, drawing continues. When the drawing screen is displayed again, the entire drawing appears (no parts are missing).

For the two-path lathe control, the screen is split vertically, and each half screen displays the tool path for either tool post.

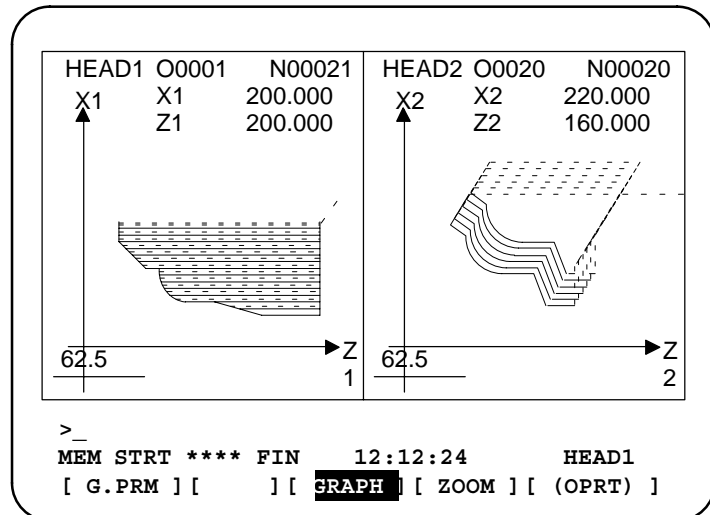

Parameter GRL (bit 0 of No. 6500) specifies which tool post is to be displayed on which side.

GRL = 0 : Tool post 1 is displayed on the left half, and tool post 2 on the right half.

GRL = 1 ; Tool post 1 is displayed on the right half, and tool post 2 on the left half.

## Restrictions

- **Feedrate**
- **Changing the graphic parameters during automatic operation**
- **Coordinate axis names**
- **Zooming drawings**

In case the feed rate is considerably high, drawing may not be executed correctly, decrease the speed by dry-run, etc. to execute drawing.

After a graphic parameter is changed, the **[REVIEW]** soft key must be pressed to initialize the graphic screen. Otherwise, the change to the graphic parameter is not reflected correctly.

The coordinate axis names are fixed to X or Z. For the two-path control, the first and second axes for tool post 1 are named X1 and Z1, respectively, and the first and second axes for tool post 2 are named X2 and Z2, respectively.

If the WORK and DIAMETER graphic parameters are not set correctly, the drawing cannot be magnified. To reduce a drawing, specify a negative value for the SCALE graphic parameter. The machine zero point is indicated with  mark.

# 13 HELP FUNCTION

The help function displays on the screen detailed information about alarms issued in the CNC and about CNC operations. The following information is displayed.

- **Detailed information of alarms**
- **Operation method**
- **Parameter table**

When the CNC is operated incorrectly or an erroneous machining program is executed, the CNC enters the alarm state. The help screen displays detailed information about the alarm that has been issued and how to reset it. The detailed information is displayed only for a limited number of P/S alarms. These alarms are often misunderstood and are rather difficult to understand.

If you are not sure about a CNC operation, refer to the help screen for information about each operation.

When setting or referring to a system parameter, if you are not sure of the number of the parameter, the help screen displays a list of parameter Nos. for each function.

## Help Function Procedure

### Procedure

- 1 Press the  key on the MDI. HELP (INITIAL MENU) screen is displayed.

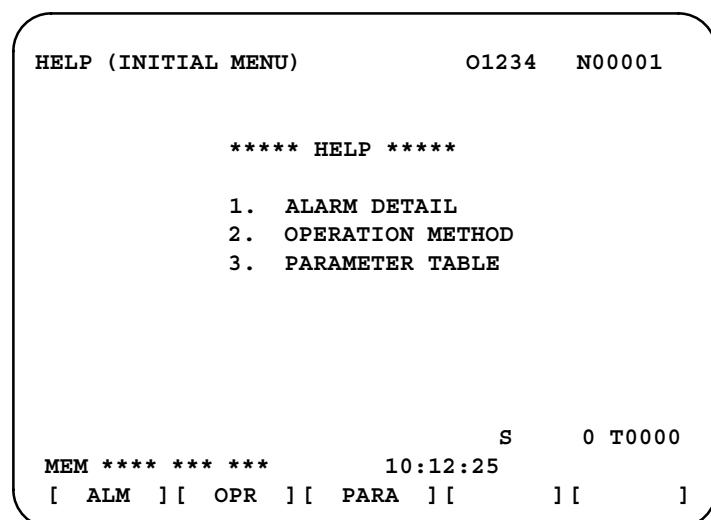

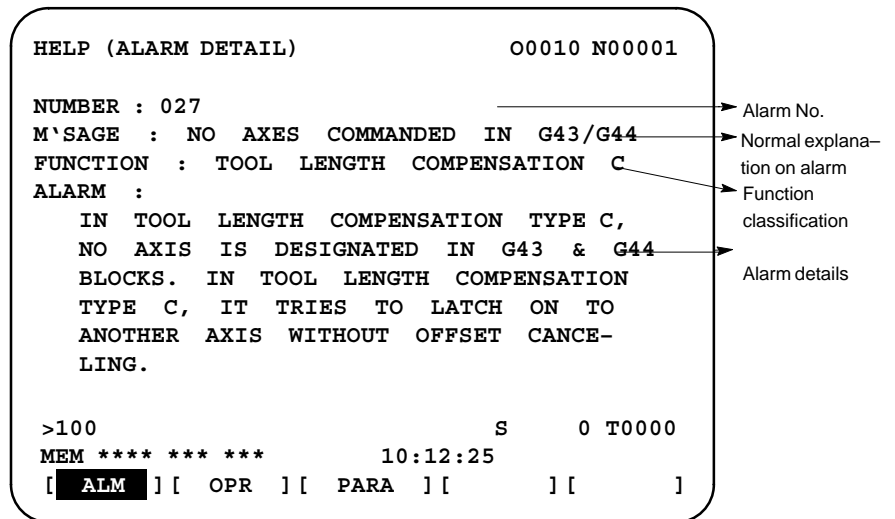

Fig. 13 (a) HELP (INITIAL MENU) Screen

The user cannot switch the screen display from the PMC screen or CUSTOM screen to the help screen. The user can return to the normal CNC screen by pressing the  key or another function key.

**ALARM DETAIL screen**

- 2 Press soft key **[ALM]** on the HELP (INITIAL MENU) screen to display detailed information about an alarm currently being raised.



**Fig. 13 (b) ALARM DETAIL Screen when P/S Alarm No. 27 is issued**

Note that only details of the alarm identified at the top of the screen are displayed on the screen.

If the alarms are all reset while the help screen is displayed, the alarm displayed on the ALARM DETAIL screen is deleted, indicating that no alarm is issued.

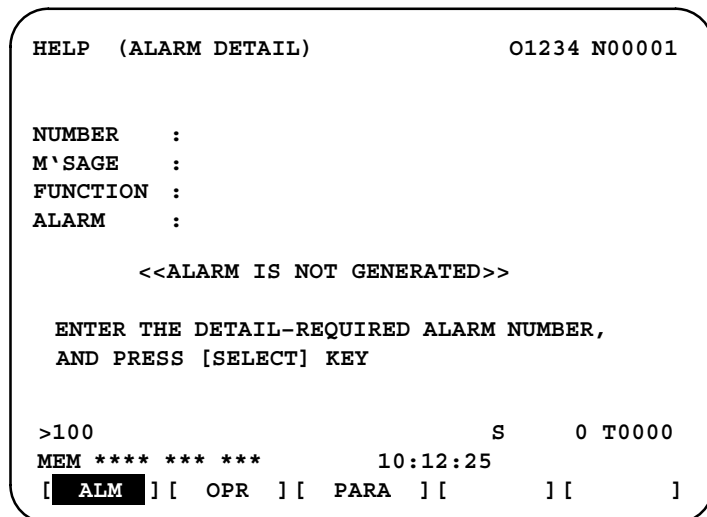

**Fig. 13 (c) ALARM DETAIL Screen when No Alarm is issued**

- 3 To get details on another alarm number, first enter the alarm number, then press soft key **[SELECT]**. This operation is useful for investigating alarms not currently being raised.

```
>100 S 0 T0000
MEM **** * 10:12:25
[] [] [] [SELECT]
```

Fig. 13 (d) How to select each ALARM DETAILS

```
HELP (ALARM DETAIL) O1234 N00001

NUMBER : 100
M`SAGE : PARAMETER WRITE ENABLE
FUNCTION :
ALARM :

 <<ALARM IS NOT GENERATED>>

>100 S 0 T0000
MEM **** * 10:12:25
[] [] [] [SELECT]
```

Fig. 13 (e) ALARM DETAIL Screen when P/S alarm No. 100 is selected

**OPERATION METHOD  
screen**

- 4 To determine an operating procedure for the CNC, press the soft key **[OPR]** key on the HELP (INITIAL MENU) screen. The OPERATION METHOD menu screen is then displayed. (See Fig. 13 (f).)

```
HELP (OPERATION METHOD) O1234 N00001

1. PROGRAM EDIT
2. SEARCH
3. RESET
4. DATA INPUT WITH MDI
5. DATA INPUT WITH TAPE
6. OUTPUT
7. INPUT WITH FANUC CASSETTE
8. OUTPUT WITH FANUC CASSETTE
9. MEMORY CLEAR

 S 0 T0000
MEM **** * 10:12:25
[ALM] [OPR] [PARA] [] []
```

Fig. 13 (f) OPERATION METHOD Menu Screen

To select an operating procedure, enter an item No. from the keyboard then press the **[SELECT]** key.



```

>1 S 0 T0000
MEM **** * 10:12:25
[] [] [] [] [SELECT]

```

Fig. 13 (g) How to select each OPERATION METHOD screen

When “1. PROGRAM EDIT” is selected, for example, the screen in Figure 13 (g) is displayed.

On each OPERATION METHOD screen, it is possible to change the displayed page by pressing the PAGE key. The current page No. is shown at the upper right corner on the screen.

```

HELP (OPERATION METHOD) 01234 N00001
<< 1. PROGRAM EDIT >> 1/4
*DELETE ALL PROGRAMS
 MODE : EDIT
 SCREEN : PROGRAM
 OPR : (0-9999) - <DELETE>

*DELETE ONE PROGRAM
 MODE : EDIT
 SCREEN : PROGRAM
 OPR : (0+PROGRAM NUMBER) - <DELETE>

>_ S 0 T0000
MEM **** * 10:12:25
[ALM] [OPR] [PARA] [] []

```

Fig. 13 (h) Selected OPERATION METHOD screen

Each item  
Page/maximum page  
Operation  
Set mode  
Operation location  
Operating procedure

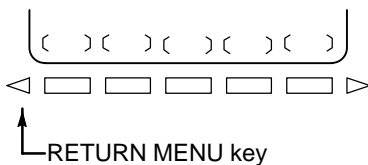

- To return to the OPERATION METHOD menu screen, press the RETURN MENU key to display “[OPR]” again, and then press the [OPR] key again.

To directly select another OPERATION METHOD screen on the screen shown in Figure 13 (h), enter an item No. from the keyboard and press the [SELECT] key.

```

>3 S 0 T0000
MEM **** * 10:12:25
[] [] [] [] [SELECT]

```

Fig. 13 (i) How to select another OPERATION METHOD screen

**PARAMETER TABLE screen**

- If you are not sure of the No. of a system parameter to be set, or to refer to a system parameter, press the [PARA] key on the HELP (INITIAL MENU) screen. A list of parameter Nos. for each function is displayed. (See Figure 13 (j).)

It is possible to change the displayed page on the parameter screen. The current page No. is shown at the upper right corner on the screen.

```

HELP (PARAMETER TABLE) 01234 N00001
 1/4

* SETTEING (No. 0000~)
* READER/PUNCHER INTERFACE (No. 0100~)
* AXIS CONTROL
 /SETTING UNIT (No. 1000~)
* COORDINATE SYSTEM (No. 1200~)
* STROKE LIMIT (No. 1300~)
* FEED RATE (No. 1400~)
* ACCEL/DECELERATION CTRL (No. 1600~)
* SERVORELATED (No. 1800~)
* DI/DO (No. 3000~)

>_ S 0 T0000
MEM **** * * * * 10:12:25
[ALM] [OPR] [PARA] [] []

```

Fig. 13 (j) PARAMETER TABLE screen

7 To exit from the help screen, press the  key or another function key.

**Explanation**

● **Configuration of the Help Screen**

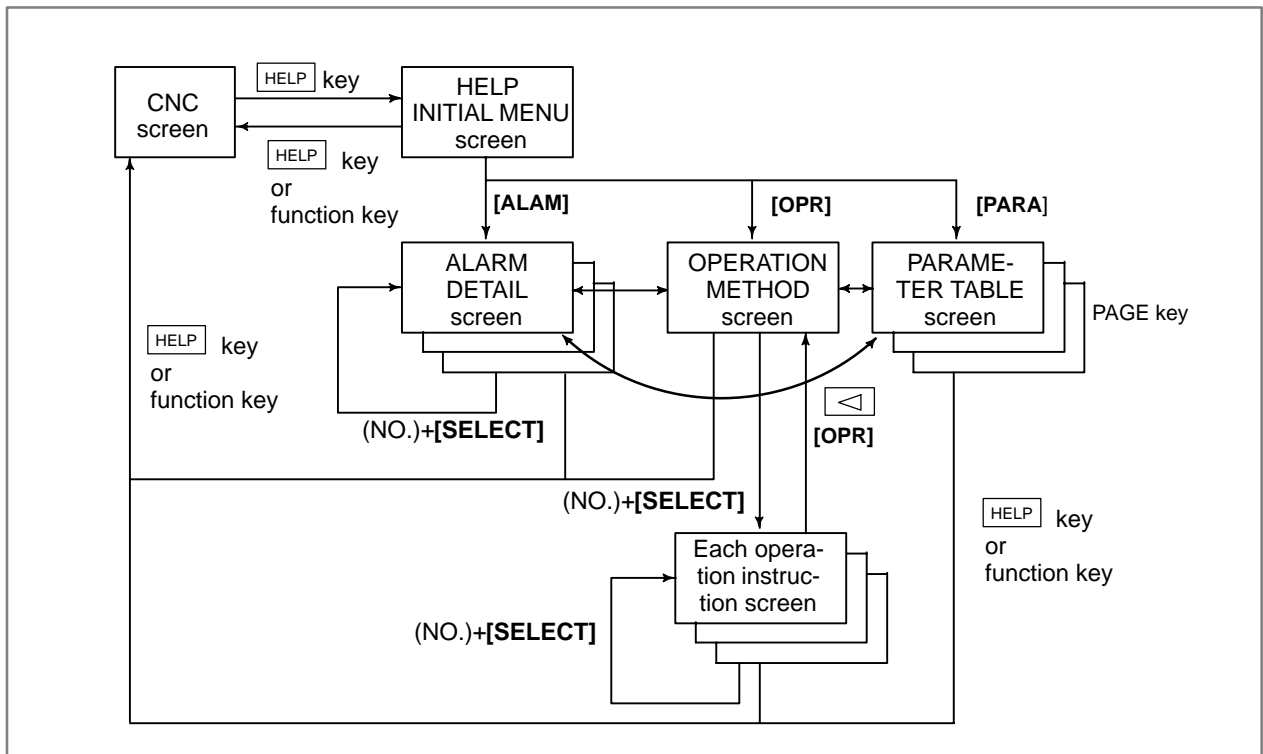

# 14

## SCREEN HARDCOPY

---

The screen hardcopy function outputs the information displayed on the CNC screen as 640\*480-dot bitmap data. This function makes it possible to produce a hard copy of a still image displayed on the CNC. The created bitmap data can be displayed on a PC.

---

### Screen Hardcopy Procedure

---

- 1 Check the parameter settings. To use the screen hardcopy function, set bit 7 of parameter 3301 to 1 and parameter 20 (I/O channel selection) to 4 (memory card I/F). Set other relative parameters (bits 0, 2, and 3 of parameter 3301) as needed. In a multipath system, set the parameters for each path.
- 2 Insert a memory card.
- 3 To start the function, set hardcopy start signal HDREQ (G67#7) to 1. Alternatively, hold down the **[SHIFT]** key for five seconds.
- 4 To end the function, press the **[CAN]** key. Alternatively, set hard copy stop signal HDABT (G67#6) to 1.
- 5 While the screen hardcopy operation is in progress, the hardcopy in progress signal (F061#3) is tied to 1. For several tens of seconds (or several seconds, for a monochrome LCD) before the hardcopy operation ends, the screen image stands still.
- 6 When the screen hardcopy operation is completed, the hardcopy in progress signal (F061#3) goes 0.

### Supplementary explanation

While the screen hardcopy operation is in progress, the screen image keeps still. This means that the clock displayed on the screen indicates the beginning and end of the operation. When the clock stops counting seconds, the hard copy operation starts. The clock resumes counting seconds when the screen hard copy operation ends.

**NOTE**

- 1 During the screen hardcopy operation, key input is disabled for several tens of seconds. Until the screen hardcopy operation ends, the screen image lies still. During this period, the hardcopy in progress signal (F061#3) is tied to 1. No other signal is output. Avoid turning off the power indiscriminately during that period.
- 2 If the **[SHIFT]** or **[CAN]** key is customized by C executor, for instance, the screen hardcopy operation may disable the **[SHIFT]** or **[CAN]** key.
- 3 A normal hard copy may not be produced while the screen image is moving.

**Limitations**

A hard copy of the following screens cannot be produced.

- 1 Screen of the FS-160i/180i/210i (CNC with personal computer function)
- 2 System alarm screen
- 3 Screen while RS-232-C is being used
- 4 Screen during automatic or manual operation (A hard copy can be produced in a rest of the operation.)

**File name**

The bitmap files created by the screen hardcopy function are named as follows, in order in which they are created after power-up:

**'HDCPY000.BMP'** (Name of the first hardcopy file created after power-up)

**'HDCPY001.BMP'** (Name of the second hardcopy file created after power-up)

:

:

**'HDCPY099.BMP'**

**NOTE**

- 1 A screen hardcopy file produced after the file HDCPY099.BMP is output will be named as HDCPY000.BMP.
- 2 If a BMP file output by the screen hardcopy function has the same name as a file present on a memory card, the file on the memory card is overwritten unconditionally.
- 3 When the hardcopy function is carried out after power is turned off and on again, the first output file is named as HDCPY000.BMP again. If the inserted memory card has a file having the same name, the file is unconditionally overwritten. Note this when continuously producing hard copies of various screens.

**Colors of data**

The number of colors used in created bitmap data depend on the display control card, the LCD hardware, and the display mode of the CNC screen. Table 14 (a) indicates the relationships.

**Table 14 (a) Colors of BMP data created by the screen hardcopy function**

|          | LCD hardware   | CNC screen display mode | Colors displayed on CNC                          | Colors used in created BMP data                                                                             | Remarks                                                                                              |
|----------|----------------|-------------------------|--------------------------------------------------|-------------------------------------------------------------------------------------------------------------|------------------------------------------------------------------------------------------------------|
| VGA card | Monochrome LCD | —                       | 2 colors                                         | 2 colors                                                                                                    | Shades of gray are not supported.                                                                    |
|          | Color LCD      | VGA-compatible mode     | Character:<br>16 colors<br>Graphic:<br>16 colors | When bit 0 of parameter 3301 is set to 0: 256 colors<br>When bit 0 of parameter 3301 is set to 1: 16 colors | Most CNC screens use this mode. Note that colors may not be normally displayed in the 16-color mode. |
|          |                | VGA mode                | 256 colors                                       | 256 colors                                                                                                  | A special screen can be prepared by C executor, for instance.                                        |

**Data size**

Table 14 (b) indicates the sizes of bitmap data created by the screen hardcopy function.

**Table 14 (b) Sizes of bitmap data created by the screen hardcopy function**

| Bitmap colors         | File size (bytes) |
|-----------------------|-------------------|
| Monochrome (2 colors) | 38,462            |
| Color (16 colors)     | 153,718           |
| Color (256 colors)    | 308,278           |

**Alarm message**

If bit 2 of parameter 3301 is set to 1, an alarm message can be output when the hardcopy operation ends in failure.  
(P/S alarm Nos. 5212 to 5214)



## **IV. MAINTENANCE**





# 1

## METHOD OF REPLACING BATTERY

This chapter describes how to replace the CNC backup battery and absolute pulse coder battery. This chapter consists of the following sections:

### 1.1 REPLACING BATTERY FOR LCD-MOUNTED TYPE *i* SERIES

### 1.2 REPLACING THE BATTERY FOR STAND-ALONE TYPE *i* SERIES

### 1.3 BATTERY IN THE PANEL *i* (3 VDC)

### 1.4 BATTERY FOR SEPARATE ABSOLUTE PULSE CODERS (6 VDC)

### 1.5 BATTERY FOR ABSOLUTE PULSE CODER BUILT INTO THE MOTOR (6 VDC)

#### Battery for memory backup

Part programs, offset data, and system parameters are stored in CMOS memory in the control unit. The power to the CMOS memory is backed up by a lithium battery mounted on the front panel of the control unit. Therefore, the above data is not lost even if the main battery fails. The backup battery is installed in the control unit prior to being shipped from the factory. This battery can provide backup for the memory contents for about a year.

When the battery voltage falls, alarm message “BAT” blinks on the LCD display and the battery alarm signal is output to the PMC. When this alarm is displayed, replace the battery as soon as possible. In general, the battery can be replaced within one or two weeks of the alarm first being issued. This, however, depends on the system configuration.

If the battery voltage subsequently drops further, backup of memory can no longer be provided. Turning on the power to the control unit in this state causes system alarm 910 (SRAM parity alarm) to be issued because the contents of memory are lost. Replace the battery, clear the entire memory, then reenter the data.

Replace the memory backup battery within a few minutes while the control unit is brought off.

The following two kinds of batteries can be used.

- Lithium battery, incorporated into the CNC control unit.
- Two alkaline dry cells (size D) in an external battery case.

#### NOTE

A lithium battery is installed as standard at the factory.

## 1.1 REPLACING BATTERY FOR LCD-MOUNTED TYPE *i* SERIES

### • Replacement procedure

When a lithium battery is used

Prepare a new lithium battery (ordering code: A02B-0200-K102 (FANUC specification: A98L-0031-0012)).

- 1) Turn on the power to the CNC. After about 30 seconds, turn off the power.
- 2) Remove the old battery from the top of the CNC control unit.  
First, unplug the battery connector, then take the battery out of its case.

The battery case of a control unit without option slots is located at the top end of the unit as shown in the figure of the previous page. The battery case of a control unit with 2 slots or 4 slots is located in the central area of the top of the unit (between fans).

- 3) Insert a new battery and reconnect the connector.

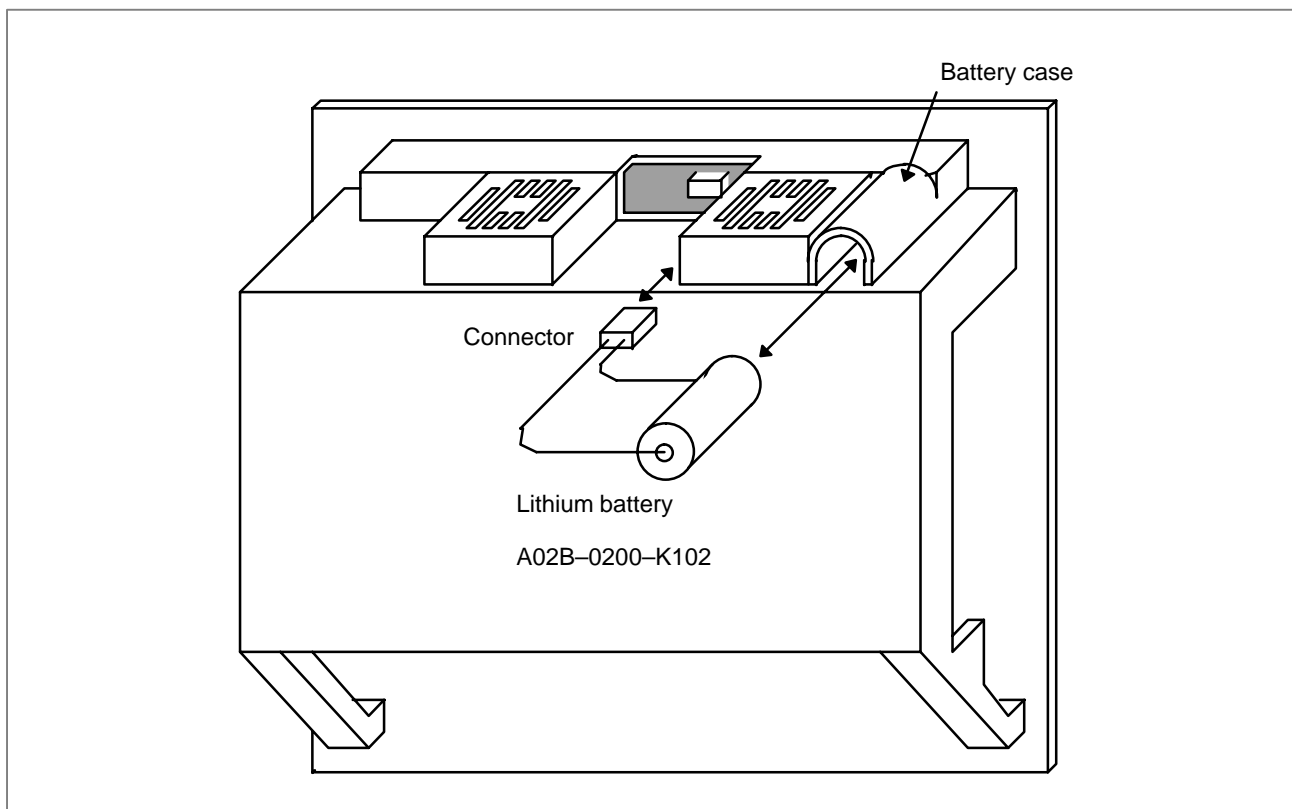

### WARNING

Using other than the recommended battery may result in the battery exploding. Replace the battery only with the specified battery (A02B-0200-K102).

**CAUTION**

Steps 1) to 3) should be completed within 30 minutes (or within 5 minutes for the 160i/180i with the PC function). Do not leave the control unit without a battery for any longer than the specified period. Otherwise, the contents of memory may be lost.

If steps 1) to 3) may not be completed within 30 minutes, save all contents of the CMOS memory to the memory card beforehand. Thus, if the contents of the CMOS memory are lost, the contents can be restored easily.

For the method of operation, refer to Maintenance manual (B-63005EN).

When discarding a battery, observe the applicable ordinances or other rules of your local government. Also, cover the terminals of the battery with vinyl tape or the like to prevent a short-circuit.

### Replacing commercial alkaline dry cells (size D)

- 1) Prepare two alkaline dry cells (size D) commercially available.
- 2) Turn on the power to the Series 16i/18i/160i/180i.
- 3) Remove the battery case cover.
- 4) Replace the cells, paying careful attention to their orientation.
- 5) Reinstall the cover onto the battery case.

#### CAUTION

When replacing the alkaline dry cells while the power is off, use the same procedure as that for lithium battery replacement described above.

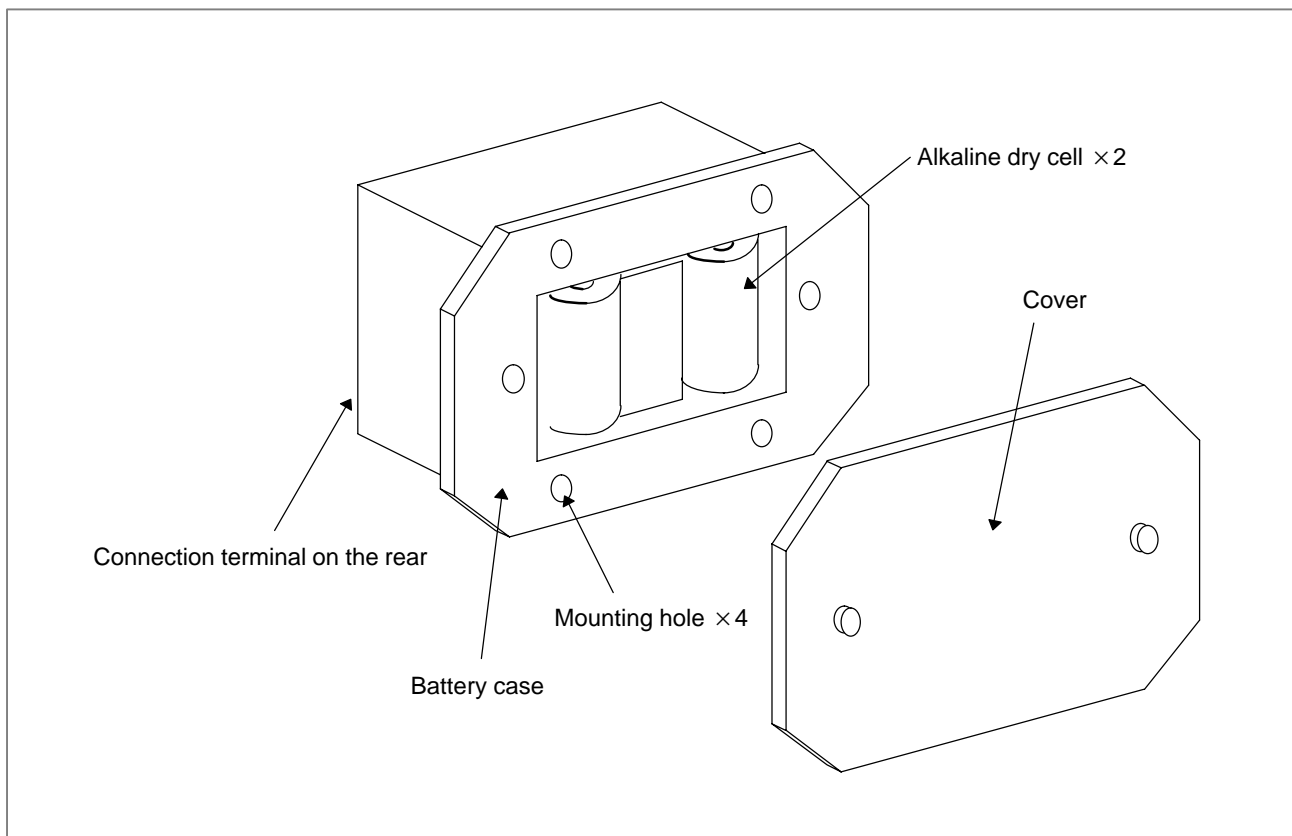

## 1.2 REPLACING THE BATTERY FOR STAND-ALONE TYPE *i* SERIES

### • Replacing the battery

If a lithium battery is used, have A02B-0200-K102 (FANUC internal code: A98L-0031-0012) handy.

(1) Turn the CNC on. About 30 seconds later, turn the CNC off.

(2) Remove the battery from the top area of the CNC unit.

Disconnect the connector first. Then, remove the battery from the battery case.

The battery case is provided in the top area of the face plate of the main CPU board.

(3) Replace the battery, then connect the connector.

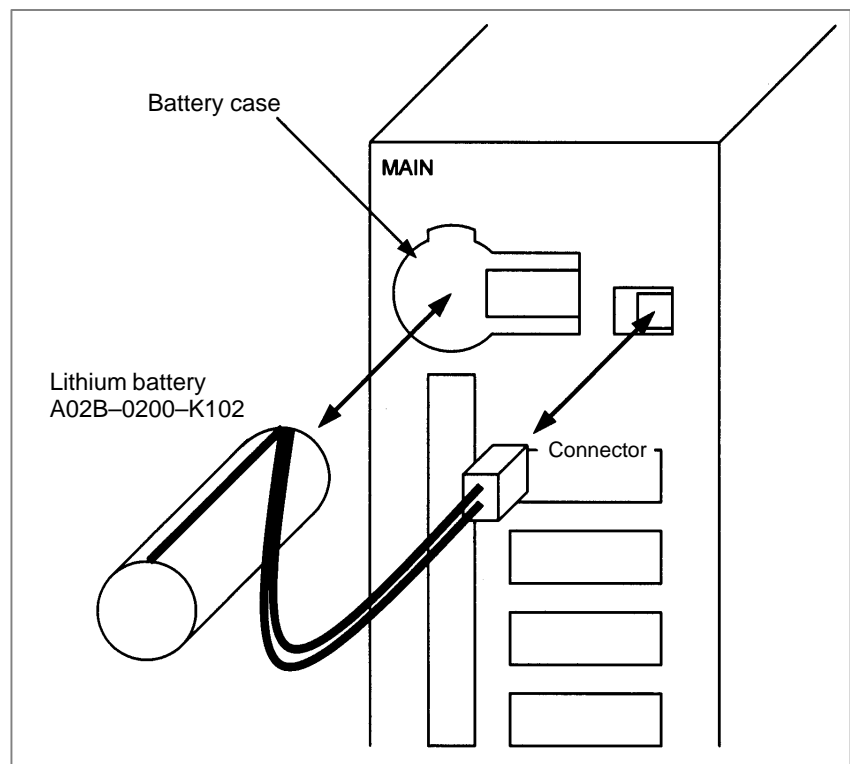

#### **WARNING**

The incorrect mounting of the battery may cause an explosion. Avoid using any battery other than the one specified here (A02B-0200-K102).

**NOTE**

Complete steps (1) to (3) within 30 minutes.

If the battery is left removed for a long time, the memory would lose the contents.

If there is a danger that the replacement cannot be completed within 30 minutes, save the whole contents of the CMOS memory to a memory card. The contents of the memory can be easily restored with the memory card in case the memory loses the contents.

Discard the dead battery, observing appropriate municipal rules and regulations. When discarding the battery, insulate the terminal with a tape so that no short-circuit would occur.

**When using commercial D-size alkaline dry cells****• Replacing the battery**

- (1) Have commercial D-size alkaline dry cells handy.
- (2) Turn the CNC on.
- (3) Remove the lid from the battery case.
- (4) Replace the old dry cells with new ones. Mount the dry cells in a correct orientation.
- (5) Replace the lid on the battery case.

**NOTE**

In the power-off state, the battery should be replaced as in the case of the lithium battery, which is described above.

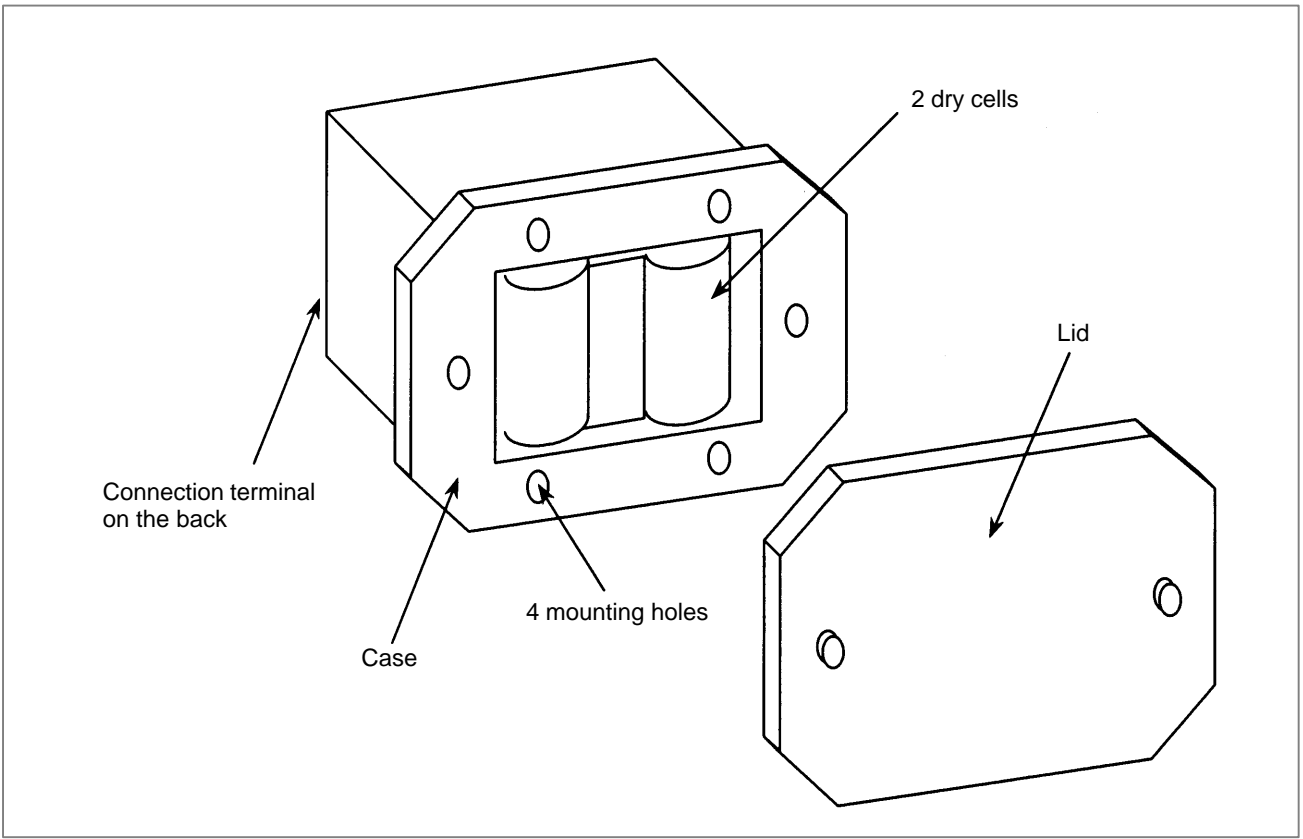

### 1.3 BATTERY IN THE PANEL *i* (3 VDC)

A lithium battery is used to back up BIOS data in the PANEL *i*. This battery is factory-set in the PANEL *i*. This battery has sufficient capacity to retain BIOS data for one year.

When the battery voltage becomes low, the LCD screen blinks. (The LCD screen also blinks if a fan alarm is issued.) If the screen blinks, replace the battery as soon as possible (within one week). FANUC recommends that the battery be replaced once per year regardless of whether a battery alarm is issued.

#### Replacing the battery

- (1) To guard against the possible loss or destruction of BIOS parameters, write down the BIOS parameter values.
- (2) Obtain a new lithium battery (A02B-0200-K102).
- (3) After power has been supplied for at least five seconds, turn off the power to PANEL *i*. Remove the intelligent terminal from the panel so that replacement work can be done from the rear of the intelligent terminal.
- (4) Detach the connector of the lithium battery, and remove the battery from the battery holder.
- (5) Run the cable for the new lithium battery as shown in the Fig. 1.3.
- (6) Attach the connector, and place the battery in the battery holder.
- (7) Install PANEL *i* again.
- (8) Turn on the power, and check that the BIOS parameters are maintained (BIOS setup is not activated forcibly).

Between removing an old battery and inserting new battery, no more than five minutes must be allowed to elapse.



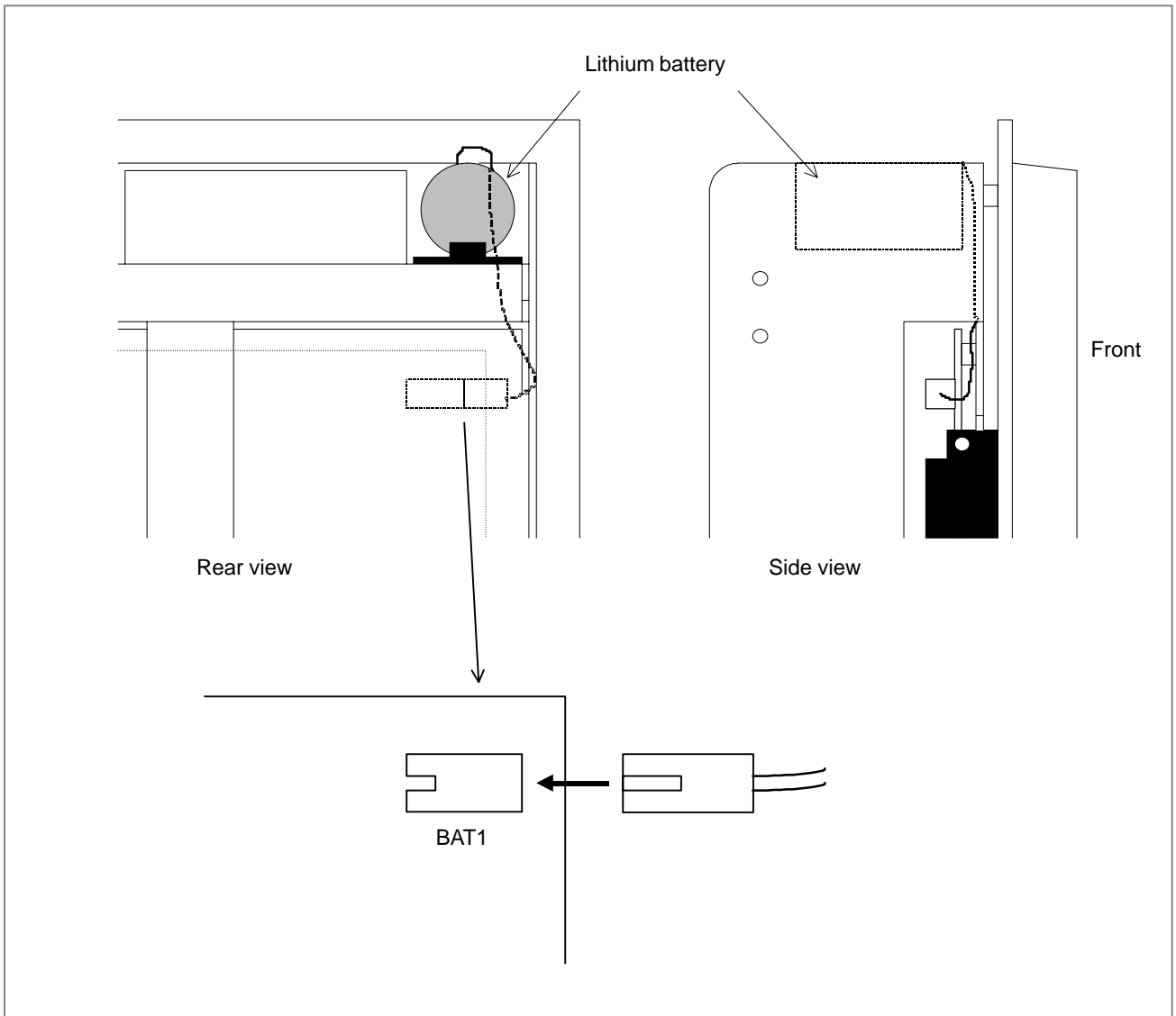

Fig. 1.3 Lithium battery connection

## 1.4 BATTERY FOR SEPARATE ABSOLUTE PULSE CODERS (6 VDC)

One battery unit can maintain current position data for six absolute pulse coders for a year.

When the voltage of the battery becomes low, APC alarms 306 to 308 (+ axis name) are displayed on the CRT display. When APC alarm 3n7 is displayed, replace the battery as soon as possible. In general, the battery should be replaced within two or three weeks, however, this depends on the number of pulse coders used.

If the voltage of the battery becomes any lower, the current positions for the pulse coders can no longer be maintained. Turning on the power to the control unit in this state causes APC alarm 300 (reference position return request alarm) to occur. Return the tool to the reference position after replacing the battery.

See Section 7.1.3 for details of connecting the battery to separate absolute pulse coders. The battery for the built-in absolute pulse coder is installed in the servo amplifier. For an explanation of the replacement procedure, refer to the FANUC SERVO MOTOR  $\alpha$  Series Maintenance Manual.

### Replacing batteries

Obtain four commercially available alkaline batteries (size D).

- (1) Turn on the power to the machine (*i* Series CNC).
- (2) Loosen the screws on the battery case connected to the interface unit of the detector separately installed, and remove the cover.
- (3) Replace the dry batteries in the case.

Note the polarity of the batteries as shown in the figure below (orient two batteries one way and the other two in the opposite direction).

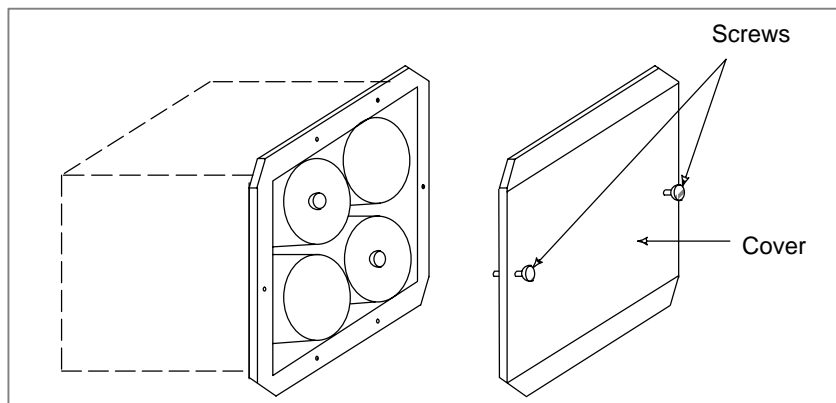

- (4) After installing the new batteries, replace the cover.
- (5) Turn off the power to the machine (*i* Series CNC).

#### WARNING

If the batteries are installed incorrectly, an explosion may occur. Never use batteries other than the specified type (Size D alkaline batteries).

#### CAUTION

Replace batteries while the power to the *i* Series CNC is on. Note that, if batteries are replaced while no power is supplied to the CNC, the recorded absolute position is lost.

## 1.5 BATTERY FOR BUILT-IN ABSOLUTE PULSE CODERS (DC6V)

When the battery voltage falls, APC alarms 306 to 308 are displayed on the screen. When APC alarm 307 is displayed, replace the battery as soon as possible. In general, the battery should be replaced within one or two weeks of the alarm first appearing. This, however, depends on the number of pulse coders being used.

If the battery voltage drops any further, the current positions for the pulse coders will be lost. Turning on the power to the control unit in this state results in APC alarm 300 (reference position return request alarm) being issued. Return the tool to the reference position after replacing the battery. So, FANUC recommends replacing the battery every year concerning without the alarm occurring.

The battery for the built-in absolute pulse coder is connected with the servo amplifier.

Note that the attachment methods of the battery and ordering specifications of battery are different from SERVO AMPLIFIER  $\alpha$  series (SVM) to SERVO AMPLIFIER  $\beta$  series.

### Replacement procedure

Replace the battery only while the power to the servo unit is on. If the battery is replaced while the power is off, all of the absolute position settings will be lost.

Replacement procedure is as follows.

1. Turn the servo unit (machine) on.
2. Place the machine in the emergency stop state.
3. Confirm that the servo motors are not active.
4. In case of SERVO AMPLIFIER  $\alpha$  series, confirm that the LED that indicates DC link charging status is not light.
5. Remove the battery and replace the battery.
6. The replacement is complete. Turn the servo unit (machine) off.

#### WARNING

- The power magnetic cabinet in which the servo units are mounted has a high-voltage section. Don't touch this section that presents a severe risk of the electric shock.
- In case of SERVO AMPLIFIER  $\alpha$  series, replace the battery after confirm that the LED that indicates DC link charging status is not light. Charged DC link has a high-voltage.
- Ensure that the replacement battery is of the correct type. Otherwise, heat, explosion or ignition will occur. Always use the specified battery.
- Pay careful attention to the polarity of the battery. Fault polarity may be the cause of heat, explosion or ignition. Also, it may be the cause of lost of the absolute position in the pulse coder.
- Attach the socket to unused connector of CX5X or CX5Y. These sockets that protect the connectors are attached to these connectors in shipping from FANUC. If connector pins of CX5X or CX5Y will short, heat, explosion or ignition will occur. Also, it may be the cause of lost of the absolute position in the pulse coder.

## SERVO AMPLIFIER $\alpha$ series (SVM)

The battery is connected in either of 2 ways as follows.

Method 1: Attach the lithium battery to the SVM.

Use the battery: A06B-6073-K001.

Method 2: Use the battery case (A06B-6050-K060).

Use the battery: A06B-6050-K061 or D-size alkaline battery.

| Method   | Item                                          | Ordering specification |
|----------|-----------------------------------------------|------------------------|
| Method 1 | Battery (Lithium battery)                     | A06B-6073-K001         |
| Method 2 | Battery (4 pieces of D-size alkaline battery) | A06B-6050-K061         |

- Attach the lithium battery to the SVM. (Method 1)  
Built the lithium (A06B-6073-K001) battery in the SVM.

[Attachment procedure]

- (1) Check the item 1 to 4 of "Replacement procedure".
- (2) Remove a battery cover from SVM.
- (3) Attach the battery as shown below.
- (4) Re-attach the cover.
- (5) Connect the connector of battery with CX5X or CX5Y of SVM.

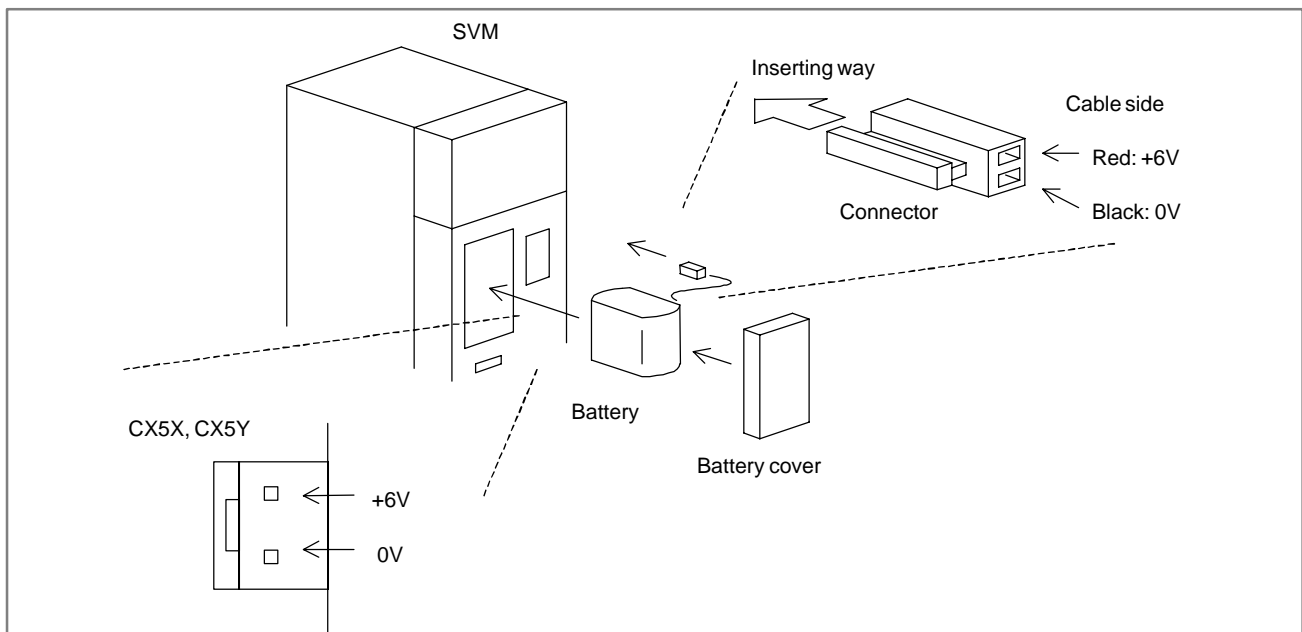

### CAUTIONS

- The connector of the battery can be connected with either of CX5X and CX5Y.
- Pay attention that the battery cable doesn't have a stretch condition. If this cable is connected on a stretch condition, a bad conductivity may be occurred.

- Replacement of batteries in the battery case. (Method 2)  
Replace four D-size alkaline batteries in the battery case installed in the machine.

[Attachment procedure]

- (1) Check the item 1 to 4 of "Replacement procedure".
- (2) Have four D-size alkaline batteries on hand.
- (3) Loosen the screws on the battery case. Remove the cover.
- (4) Replace the alkaline batteries in the case. Pay careful attention to the polarity of the alkaline batteries.
- (5) Attach the cover.

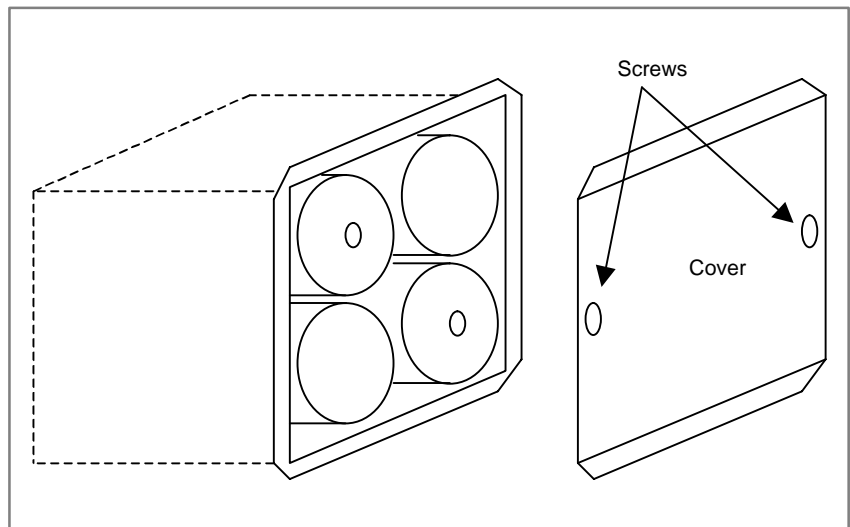

## SERVO AMPLIFIER $\beta$ series

The battery is connected in either of 2 ways as follows.

Method 1: Attach the lithium battery to the SVM.

Use the battery: A06B-6093-K001.

Method 2: Use the battery case (A06B-6050-K060).

Use the battery: A06B-6050-K061 or D-size alkaline battery.

| Method   | Item                                          | Ordering specification |
|----------|-----------------------------------------------|------------------------|
| Method 1 | Battery (Lithium battery)                     | A06B-6093-K001         |
| Method 2 | Battery (4 pieces of D-size alkaline battery) | A06B-6050-K061         |

- Attach the lithium battery to the amplifier. (Method 1)  
Attach the lithium (A06B-6093-K001) battery to the amplifier.

[Attachment procedure]

- (1) Check the item 1 to 3 of "Replacement procedure".
- (2) In case of SVU-12 or SVU-20, remove the battery cover under the servo unit grasping its left and right sides. In case of SVU-40 or SVU-80, remove the cover attached on right side of the servo unit grasping its upper and lower sides.
- (3) Remove the battery from the servo unit.
- (4) Replace the battery and connect the battery cable with the connector CX5X or CX5Y of the servo unit.
- (5) Mount the battery cover.

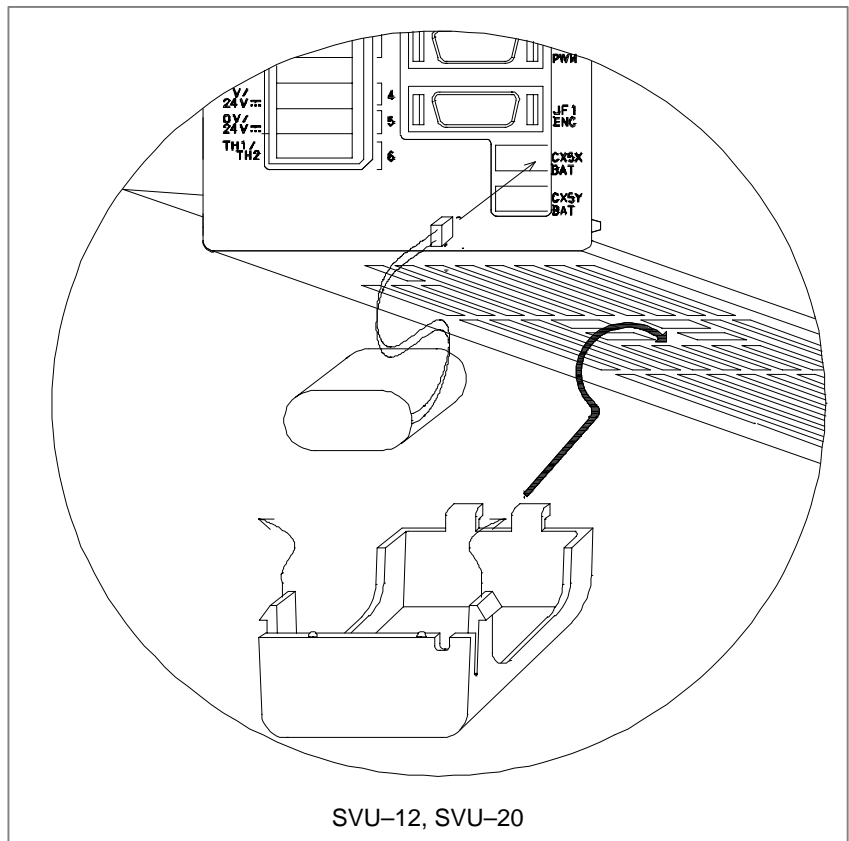

SVU-12, SVU-20

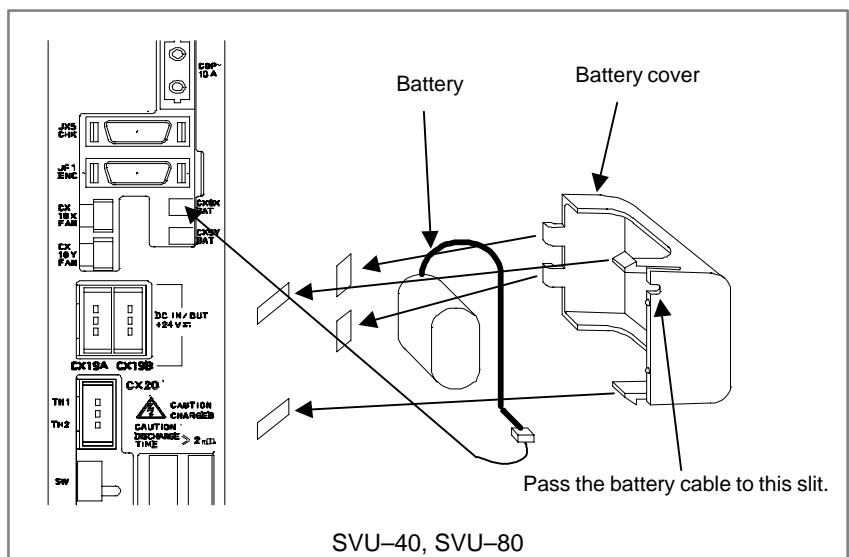

SVU-40, SVU-80

**CAUTIONS**

- The connector of the battery can be connected with either of CX5X and CX5Y.

- Replacement of batteries in the battery case. (Method 2)  
Replace four D-size alkaline batteries in the battery case installed in the machine.

[Attachment procedure]

- (1) Check the item 1 to 3 of "Replacement procedure".
- (2) Have four D-size alkaline batteries on hand.
- (3) Loosen the screws on the battery case. Remove the cover.
- (4) Replace the alkaline batteries in the case. Pay careful attention to the polarity of the alkaline batteries.
- (5) Attach the cover.

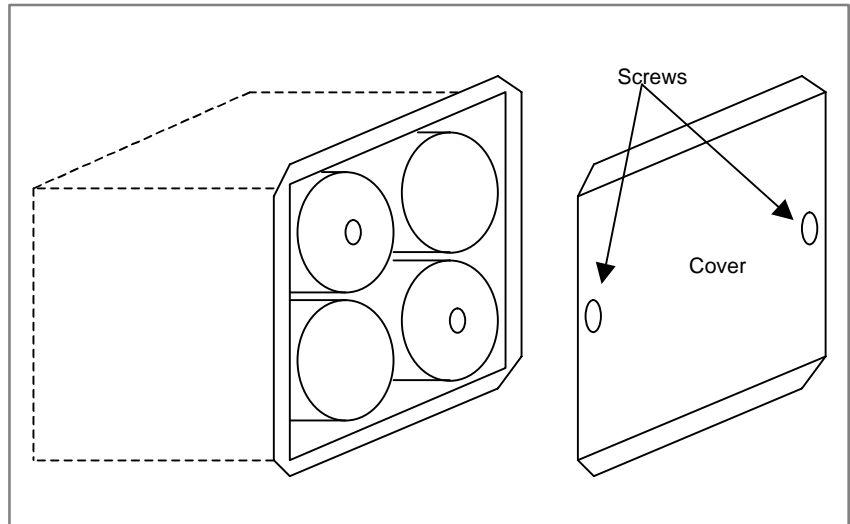

### Used batteries

Old batteries should be disposed as "INDUSTRIAL WASTES" according to the regulations of the country or autonomy where your machine has been installed.





# APPENDIX



# A TAPE CODE LIST

| ISO code  |          |      |   |   |   |   |   |   | EIA code  |   |   |   |   |   |   |   |   | Remarks   |  |                |  |
|-----------|----------|------|---|---|---|---|---|---|-----------|---|---|---|---|---|---|---|---|-----------|--|----------------|--|
| Character | 8        | 7    | 6 | 5 | 4 | 3 | 2 | 1 | Character | 8 | 7 | 6 | 5 | 4 | 3 | 2 | 1 |           |  | Custom macro B |  |
|           | Not used | Used |   |   |   |   |   |   |           |   |   |   |   |   |   |   |   |           |  |                |  |
| 0         |          |      | ○ | ○ | ○ |   |   |   | 0         |   |   | ○ |   | ○ |   |   |   | Number 0  |  |                |  |
| 1         | ○        |      | ○ | ○ | ○ |   |   | ○ | 1         |   |   |   |   | ○ |   |   | ○ | Number 1  |  |                |  |
| 2         | ○        |      | ○ | ○ | ○ |   |   | ○ | 2         |   |   |   |   | ○ |   |   | ○ | Number 2  |  |                |  |
| 3         |          |      | ○ | ○ | ○ |   |   | ○ | 3         |   |   | ○ |   | ○ |   |   | ○ | Number 3  |  |                |  |
| 4         | ○        |      | ○ | ○ | ○ |   |   | ○ | 4         |   |   |   |   | ○ |   |   | ○ | Number 4  |  |                |  |
| 5         |          |      | ○ | ○ | ○ |   |   | ○ | 5         |   |   |   | ○ |   | ○ |   | ○ | Number 5  |  |                |  |
| 6         |          |      | ○ | ○ | ○ |   |   | ○ | 6         |   |   | ○ |   | ○ |   |   | ○ | Number 6  |  |                |  |
| 7         | ○        |      | ○ | ○ | ○ |   |   | ○ | 7         |   |   |   |   | ○ |   |   | ○ | Number 7  |  |                |  |
| 8         | ○        |      | ○ | ○ | ○ |   |   | ○ | 8         |   |   |   | ○ | ○ |   |   |   | Number 8  |  |                |  |
| 9         |          |      | ○ | ○ | ○ |   |   | ○ | 9         |   |   | ○ | ○ | ○ |   |   | ○ | Number 9  |  |                |  |
| A         |          | ○    |   |   |   |   |   | ○ | a         |   | ○ | ○ |   | ○ |   |   | ○ | Address A |  |                |  |
| B         |          | ○    |   |   |   |   |   | ○ | b         |   | ○ | ○ |   | ○ |   |   | ○ | Address B |  |                |  |
| C         | ○        | ○    |   |   |   |   |   | ○ | c         |   | ○ | ○ | ○ |   |   |   | ○ | Address C |  |                |  |
| D         |          | ○    |   |   |   |   |   | ○ | d         |   | ○ | ○ |   | ○ |   |   | ○ | Address D |  |                |  |
| E         | ○        | ○    |   |   |   |   |   | ○ | e         |   | ○ | ○ | ○ |   |   |   | ○ | Address E |  |                |  |
| F         | ○        | ○    |   |   |   |   |   | ○ | f         |   | ○ | ○ | ○ |   |   |   | ○ | Address F |  |                |  |
| G         |          | ○    |   |   |   |   |   | ○ | g         |   | ○ | ○ |   | ○ |   |   | ○ | Address G |  |                |  |
| H         |          | ○    |   |   |   |   |   | ○ | h         |   | ○ | ○ | ○ | ○ |   |   |   | Address H |  |                |  |
| I         | ○        | ○    |   |   |   |   |   | ○ | i         |   | ○ | ○ | ○ | ○ |   |   | ○ | Address I |  |                |  |
| J         | ○        | ○    |   |   |   |   |   | ○ | j         |   | ○ | ○ |   | ○ |   |   | ○ | Address J |  |                |  |
| K         |          | ○    |   |   |   |   |   | ○ | k         |   | ○ | ○ |   | ○ |   |   | ○ | Address K |  |                |  |
| L         | ○        | ○    |   |   |   |   |   | ○ | l         |   | ○ |   |   | ○ |   |   | ○ | Address L |  |                |  |
| M         |          | ○    |   |   |   |   |   | ○ | m         |   | ○ | ○ |   | ○ |   |   |   | Address M |  |                |  |
| N         |          | ○    |   |   |   |   |   | ○ | n         |   | ○ |   |   | ○ |   |   | ○ | Address N |  |                |  |
| O         | ○        | ○    |   |   |   |   |   | ○ | o         |   | ○ |   |   | ○ |   |   | ○ | Address O |  |                |  |
| P         |          | ○    |   |   |   |   |   | ○ | p         |   | ○ | ○ |   | ○ |   |   | ○ | Address P |  |                |  |
| Q         | ○        | ○    |   |   |   |   |   | ○ | q         |   | ○ | ○ | ○ | ○ |   |   |   | Address Q |  |                |  |
| R         | ○        | ○    |   |   |   |   |   | ○ | r         |   | ○ |   | ○ | ○ |   |   | ○ | Address R |  |                |  |
| S         |          | ○    |   |   |   |   |   | ○ | s         |   |   | ○ | ○ |   |   |   | ○ | Address S |  |                |  |
| T         | ○        | ○    |   |   |   |   |   | ○ | t         |   |   | ○ |   | ○ |   |   | ○ | Address T |  |                |  |
| U         |          | ○    |   |   |   |   |   | ○ | u         |   |   | ○ | ○ |   |   |   |   | Address U |  |                |  |
| V         |          | ○    |   |   |   |   |   | ○ | v         |   |   | ○ |   | ○ |   |   | ○ | Address V |  |                |  |
| W         | ○        | ○    |   |   |   |   |   | ○ | w         |   |   | ○ |   | ○ |   |   | ○ | Address W |  |                |  |
| X         | ○        | ○    |   |   |   |   |   | ○ | x         |   |   | ○ | ○ |   |   |   | ○ | Address X |  |                |  |
| Y         |          | ○    |   |   |   |   |   | ○ | y         |   |   | ○ | ○ | ○ |   |   |   | Address Y |  |                |  |
| Z         |          | ○    |   |   |   |   |   | ○ | z         |   |   | ○ | ○ | ○ |   |   | ○ | Address Z |  |                |  |

| ISO code  |   |   |   |   |   |   |   |   | EIA code            |   |   |   |   |   |   |   |   | Remarks                                                                                 |      |                |
|-----------|---|---|---|---|---|---|---|---|---------------------|---|---|---|---|---|---|---|---|-----------------------------------------------------------------------------------------|------|----------------|
| Character | 8 | 7 | 6 | 5 | 4 | 3 | 2 | 1 | Character           | 8 | 7 | 6 | 5 | 4 | 3 | 2 | 1 |                                                                                         |      | Custom macro B |
|           |   |   |   |   |   |   |   |   |                     |   |   |   |   |   |   |   |   | Not used                                                                                | Used |                |
| DEL       | ○ | ○ | ○ | ○ | ○ | ○ | ○ | ○ | Del                 |   | ○ | ○ | ○ | ○ | ○ | ○ | ○ | Delete (deleting a mispunch)                                                            | ×    | ×              |
| NUL       |   |   |   |   |   |   | ○ |   | Blank               |   |   |   |   |   |   | ○ |   | No punch. With EIA code, this code cannot be used in a significant information section. | ×    | ×              |
| BS        | ○ |   |   |   | ○ | ○ |   |   | BS                  |   |   | ○ | ○ | ○ |   | ○ |   | Backspace                                                                               | ×    | ×              |
| HT        |   |   |   |   | ○ | ○ |   | ○ | Tab                 |   |   | ○ | ○ | ○ | ○ | ○ |   | Tabulator                                                                               | ×    | ×              |
| LF or NL  |   |   |   |   | ○ | ○ |   | ○ | CR or EOB           | ○ |   |   |   |   |   | ○ |   | End of block                                                                            |      |                |
| CR        | ○ |   |   |   | ○ | ○ | ○ | ○ | —                   |   |   |   |   |   |   |   |   | Carriage return                                                                         | ×    | ×              |
| SP        | ○ |   | ○ |   |   | ○ |   |   | SP                  |   |   |   | ○ | ○ |   |   |   | Space                                                                                   | □    | □              |
| %         | ○ |   | ○ |   |   | ○ | ○ | ○ | ER                  |   |   |   |   | ○ | ○ | ○ | ○ | Absolute rewind stop                                                                    |      |                |
| (         |   |   | ○ |   | ○ | ○ |   |   | (2-4-5)             |   |   |   |   | ○ | ○ | ○ | ○ | Control out (start of comment)                                                          |      |                |
| )         | ○ |   | ○ |   | ○ | ○ |   | ○ | (2-4-7)             | ○ |   |   |   | ○ | ○ | ○ | ○ | Control in (end of comment)                                                             |      |                |
| +         |   |   | ○ |   | ○ | ○ |   | ○ | +                   |   | ○ | ○ | ○ | ○ |   |   |   | Plus sign                                                                               | Δ    |                |
| -         |   |   | ○ |   | ○ | ○ | ○ | ○ | -                   |   | ○ |   |   |   | ○ |   |   | Minus sign                                                                              |      |                |
| :         |   |   | ○ | ○ | ○ | ○ |   | ○ | —                   |   |   |   |   |   |   |   |   | Colon (address 0)                                                                       |      |                |
| /         | ○ |   | ○ |   | ○ | ○ | ○ | ○ | /                   |   |   | ○ | ○ | ○ |   |   | ○ | Optional block skip                                                                     |      |                |
| .         |   |   | ○ |   | ○ | ○ | ○ | ○ | .                   |   | ○ | ○ | ○ | ○ | ○ | ○ | ○ | Period (decimal point)                                                                  |      |                |
| #         | ○ |   | ○ |   |   | ○ |   | ○ | Parameter (No.6012) |   |   |   |   |   |   |   |   | Sharp                                                                                   |      |                |
| \$        |   |   | ○ |   |   | ○ | ○ |   | —                   |   |   |   |   |   |   |   |   | Dollar sign                                                                             | ×    | ×              |
| &         | ○ |   | ○ |   |   | ○ | ○ | ○ | &                   |   |   |   |   | ○ | ○ | ○ | ○ | Ampersand                                                                               | Δ    | ○              |
| '         |   |   | ○ |   |   | ○ | ○ | ○ | —                   |   |   |   |   |   |   |   |   | Apostrophe                                                                              | Δ    | Δ              |
| *         | ○ |   | ○ |   |   | ○ | ○ | ○ | Parameter (No.6010) |   |   |   |   |   |   |   |   | Asterisk                                                                                | Δ    |                |
| ,         | ○ |   | ○ |   |   | ○ | ○ |   | ,                   |   |   | ○ | ○ | ○ | ○ | ○ | ○ | Comma                                                                                   |      |                |
| ;         | ○ |   | ○ | ○ | ○ | ○ |   | ○ | —                   |   |   |   |   |   |   |   |   | Semicolon                                                                               | ×    | ×              |
| <         |   |   | ○ | ○ | ○ | ○ |   |   | —                   |   |   |   |   |   |   |   |   | Left angle bracket                                                                      | Δ    | Δ              |
| =         | ○ |   | ○ | ○ | ○ | ○ |   | ○ | Parameter (No.6011) |   |   |   |   |   |   |   |   | Equal sign                                                                              | Δ    |                |
| >         | ○ |   | ○ | ○ | ○ | ○ |   | ○ | —                   |   |   |   |   |   |   |   |   | Right angle bracket                                                                     | Δ    | Δ              |
| ?         |   |   | ○ | ○ | ○ | ○ |   | ○ | —                   |   |   |   |   |   |   |   |   | Question mark                                                                           | Δ    | ○              |
| @         | ○ | ○ |   |   |   | ○ |   |   | —                   |   |   |   |   |   |   |   |   | Commercial at mark                                                                      | Δ    | ○              |
| "         |   |   | ○ |   |   |   |   | ○ | —                   |   |   |   |   |   |   |   |   | Quotation mark                                                                          | Δ    | Δ              |
| [         | ○ | ○ |   | ○ | ○ | ○ |   | ○ | Parameter (No.6013) |   |   |   |   |   |   |   |   | Left square bracket                                                                     | Δ    |                |
| ]         | ○ | ○ |   | ○ | ○ | ○ |   | ○ | Parameter (No.6014) |   |   |   |   |   |   |   |   | Right square bracket                                                                    | Δ    |                |

**NOTE**

- 1 The symbols used in the remark column have the following meanings.
  - (Space) : The character will be registered in memory and has a specific meaning.  
If it is used incorrectly in a statement other than a comment, an alarm occurs.
  - × : The character will not be registered in memory, but will be ignored.
  - △ : The character will be registered in memory, but will be ignored during program execution.
  - : The character will be registered in memory. If it is used in a statement other than a comment, an alarm occurs.
  - : If it is used in a statement other than a comment, the character will not be registered in memory. If it is used in a comment, it will be registered in memory.
- 2 Codes not in this table are ignored if their parity is correct.
- 3 Codes with incorrect parity cause the TH alarm. But they are ignored without generating the TH alarm when they are in the comment section.
- 4 A character with all eight holes punched is ignored and does not generate TH alarm in EIA code.

# B LIST OF FUNCTIONS AND TAPE FORMAT

Some functions cannot be added as options depending on the model.  
 In the tables below, IP \_: presents a combination of arbitrary axis addresses using X and Z.  
 x = 1st basic axis (X usually)  
 z = 2nd basic axis (Z usually)

(1/3)

| Functions                         | Illustration | Tape format                                                                                                                         |
|-----------------------------------|--------------|-------------------------------------------------------------------------------------------------------------------------------------|
| Positioning (G00)                 |              | G00 IP_;                                                                                                                            |
| Linear interpolation (G01)        |              | G01 IP_ F_;                                                                                                                         |
| Circular interpolation (G02, G03) |              | $\left\{ \begin{matrix} G02 \\ G03 \end{matrix} \right\} X\_ Z\_ \left\{ \begin{matrix} R\_ \\ I\_ K\_ \end{matrix} \right\} F\_;$  |
| Dwell (G04)                       |              | G04 $\left\{ \begin{matrix} X\_ \\ P\_ \end{matrix} \right\} ;$                                                                     |
| Cylindrical interpolation (G07.1) |              | G07.1 IP_r_ ;<br>Cylindrical interpolation mode<br>G07.1 IP0 ;<br>Cylindrical interpolation mode<br>cancel<br>r: Radius of cylinder |
| Look-ahead control (G08)          |              | G08 P1 ;<br>Look-ahead control mode on<br>G08 P0 ;<br>Look-ahead control mode off                                                   |

(1/3)

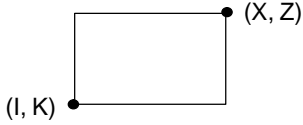
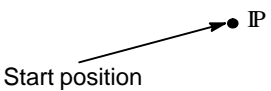
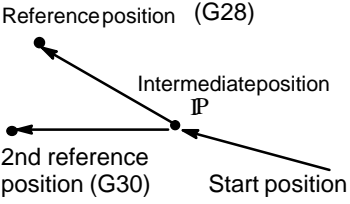
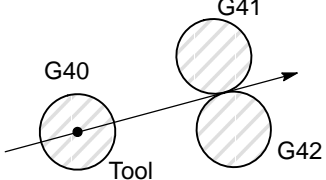
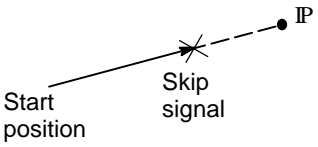
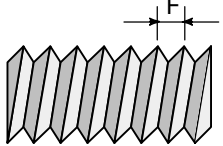
| Functions                                                                       | Illustration                                                                         | Tape format                                                                                                                                                   |
|---------------------------------------------------------------------------------|--------------------------------------------------------------------------------------|---------------------------------------------------------------------------------------------------------------------------------------------------------------|
| Change of offsetvalue by program(G10)                                           |                                                                                      | Tool geometry offset value<br>G10 P_ X_ Z_ R_ Q_ ;<br>P=1000+Geometry offset number<br>Tool wear offset value<br>G10 P_ X_ Z_ R_ Q_ ;<br>P=Wear offset number |
| Plane selection<br>(G17, G18, G19)                                              |                                                                                      | G17 ;<br>G18 ;<br>G19 ;                                                                                                                                       |
| Inch/metric conversion<br>(G20, G21)                                            |                                                                                      | Inch input : G20<br>Metric input : G21                                                                                                                        |
| Stored stroke check 2, 3<br>(G22, G23)                                          |     | G22X_ Z_ I_ K_ ;<br>G23 ;                                                                                                                                     |
| Spindle speed fluctuation<br>detection (G25, G26)                               |                                                                                      | G25 ;<br>G26 P_ Q_ R_ ;                                                                                                                                       |
| Reference position return<br>check (G27)                                        |    | G27 IP_ ;                                                                                                                                                     |
| Reference position return<br>(G28)<br>2nd, reference position re-<br>turn (G30) |  | G28 IP_ ;<br>G30 IP_ ;                                                                                                                                        |
| Cutter compensation<br>(G40, G41, G42)                                          |   | $\left\{ \begin{matrix} G41 \\ G42 \end{matrix} \right\} P_ ;$<br>P : Tool offset number<br>G40 : Cancel                                                      |
| Skip fubction (G31)                                                             |   | G31 IP_ F_ ;                                                                                                                                                  |
| Thread cutting (G32)                                                            |   | Equal lead thread cutting<br>G32 IP_ F_ ;                                                                                                                     |

(2/3)

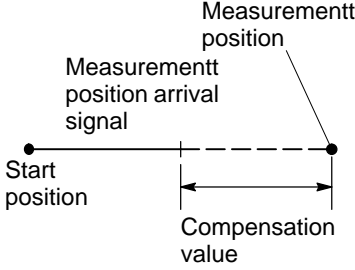
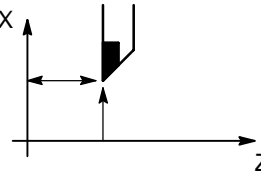
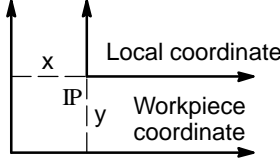
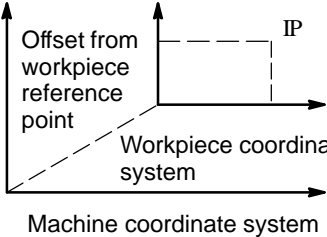
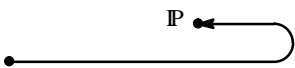
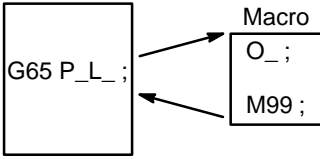
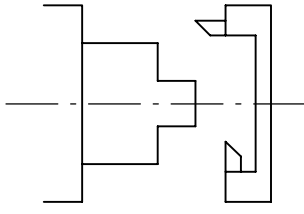
| Functions                                                | Illustration                                                                        | Tape format                                                                                                                                                     |
|----------------------------------------------------------|-------------------------------------------------------------------------------------|-----------------------------------------------------------------------------------------------------------------------------------------------------------------|
| Automatic tool compensation (G36, G37)                   |   | G36 X <sub>xa</sub> ;<br>G37 Z <sub>za</sub> ;                                                                                                                  |
| Coordinate system setting<br>Spindle speed setting (G50) |    | G50 X <sub>Z</sub> ;<br>Coordinate system setting<br>G50 S <sub>;</sub> ; Spindle speed setting                                                                 |
| Local coordinate system setting (G52)                    |   | G52 IP <sub>;</sub> ;                                                                                                                                           |
| Machine coordinate system selection (G53)                |                                                                                     | G53 IP <sub>;</sub> ;                                                                                                                                           |
| Workpiece coordinate system selection (G54 to G59)       |  | { G54<br>: IP <sub>;</sub><br>G59 }                                                                                                                             |
| Unidirectional positioning (G60)                         |  | G60 IP <sub>;</sub> ;                                                                                                                                           |
| Custom macro (G65, G66, G67)                             |  | One-shot call<br>G65 P <sub>L</sub> <argument> ;<br>P : Program number<br>L : Repetition count<br>Modal call<br>G66 P <sub>L</sub> <argument> ;<br>G67 ; Cancel |
| Mirror image for double turret (G68, G69)                |  | G68 ;<br>Mirror image for double turret on<br>G69 ; Mirror image cancel                                                                                         |

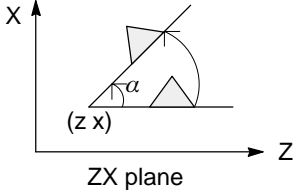
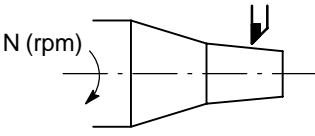
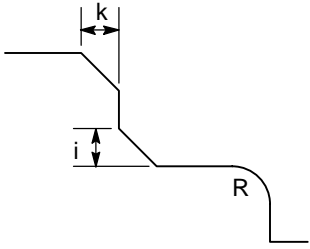

(3/3)

| Functions                                          | Illustration                                                                                                                  | Tape format                                                                                                                                                                                                                                                                                                                                                                                         |
|----------------------------------------------------|-------------------------------------------------------------------------------------------------------------------------------|-----------------------------------------------------------------------------------------------------------------------------------------------------------------------------------------------------------------------------------------------------------------------------------------------------------------------------------------------------------------------------------------------------|
| Coordinate system rotation<br>(G68.1, G69.1)       |  <p style="text-align: center;">ZX plane</p> | $G68.1 \left\{ \begin{array}{l} G17 X\_Y\_ \\ G18 Z\_X\_ \\ G19 Y\_Z\_ \end{array} \right\} R_{\alpha};$ G69.1 ; Cancel                                                                                                                                                                                                                                                                             |
| Feed per minute (G98)<br>Feed per revolution (G99) | mm/min inch/min<br>mm/rev inch/rev                                                                                            | G98 ... F_ ; (Feed per minute)<br>G99 ... F_ ; (Feed per revolution)                                                                                                                                                                                                                                                                                                                                |
| Constant surface speed control (G96/G97)           | m/min or feet/min<br>                        | G96 S_ ;<br>G97 ; Cancel                                                                                                                                                                                                                                                                                                                                                                            |
| Chamfering, Corner R                               |                                             | $X_ ; \left\{ \begin{array}{l} C \pm k \\ R_- \end{array} \right\} P_- ;$ $Z_ ; \left\{ \begin{array}{l} C \pm i \\ R_- \end{array} \right\} P_- ;$                                                                                                                                                                                                                                                 |
| Canned cycle<br>(G71 to G76)<br>(G90, G92, G94)    | Refer to II.13. FUNCTIONS TO SIMPLIFY PROGRAMMING                                                                             | N_ G70 P_ Q_ ;<br>G71 U_ R_ ;<br>G71 P_ Q_ U_ W_ F_ S_ T_ ;<br>G72 W_ R_ ;<br>G72 P_ Q_ U_ W_ F_ S_ T_ ;<br>G73 U_ W_ R_ ;<br>G73 P_ Q_ U_ W_ F_ S_ T_ ;<br>G74 R_ ;<br>G74 X(u)_ Z(w)_ P_ Q_ R_ F_ ;<br>G75 R_ ;<br>G75 X(u)_ Z(w)_ P_ Q_ R_ F_ ;<br>G76 P_ Q_ R_ ;<br>G76 X(u)_ Z(w)_ P_ Q_ R_ F_ ;<br>$\left\{ \begin{array}{l} G90 \\ G92 \end{array} \right\} X_ Z_ I_ F_ ;$ G94 X_ Z_ K_ F_ ; |
| Absolute/incremental programming                   |                                                                                                                               | X_ Z_ C_ ; Absolute programming<br>U_ W_ H_ ; Incremental programming<br>(Identified by an address word specified with a G function such as G00 or G01)                                                                                                                                                                                                                                             |

# C RANGE OF COMMAND VALUE

## Linear axis

- In case of millimeter input, feed screw is millimeter

|                             | Increment system                                                                               |                                                                                                |
|-----------------------------|------------------------------------------------------------------------------------------------|------------------------------------------------------------------------------------------------|
|                             | IS-B                                                                                           | IS-C                                                                                           |
| Least input increment       | 0.001 mm                                                                                       | 0.0001 mm                                                                                      |
| Least command increment     | X : 0.0005 mm<br>Z : 0.001 mm                                                                  | X : 0.00005 mm<br>Z : 0.0001 mm                                                                |
| Max. programmable dimension | ±99999.999 mm                                                                                  | ±9999.9999 mm                                                                                  |
| Max. rapid traverse *1      | 240000 mm/min                                                                                  | 100000 mm/min                                                                                  |
| Feedrate range *1           | Feed per minute :<br>1 to 240000 mm/min<br>Feed per revolution<br>0.0001 to 500.0000<br>mm/rev | Feed per minute :<br>1 to 100000 mm/min<br>Feed per revolution<br>0.0001 to 500.0000<br>mm/rev |
| Incremental feed            | 0.001, 0.01, 0.1, 1mm/step                                                                     | 0.0001, 0.001, 0.01, 0.1<br>mm/step                                                            |
| Tool compensation           | 0 to ±999.999 mm                                                                               | 0 to ±999.9999 mm                                                                              |
| Backlash compensation       | 0 to ±0.255 mm                                                                                 | 0 to ±0.255 mm                                                                                 |
| Dwell time                  | 0 to 99999.999 sec                                                                             | 0 to 99999.999 sec                                                                             |

- In case of inch input, feed screw is millimeter

|                             | Increment system                                                                                      |                                                                                                       |
|-----------------------------|-------------------------------------------------------------------------------------------------------|-------------------------------------------------------------------------------------------------------|
|                             | IS-B                                                                                                  | IS-C                                                                                                  |
| Least input increment       | 0.0001 inch                                                                                           | 0.00001 inch                                                                                          |
| Least command increment     | X : 0.00005 inch<br>Z : 0.0001 inch                                                                   | X : 0.000005 inch<br>Z : 0.00001 inch                                                                 |
| Max. programmable dimension | ±9999.9999 inch                                                                                       | ±393.70078 inch                                                                                       |
| Max. rapid traverse *1      | 240000 mm/min                                                                                         | 100000 mm/min                                                                                         |
| Feedrate range *1           | Feed per minute :<br>0.01 to 9600 inch/min<br>Feed per revolution<br>0.000001 to 9.999999<br>inch/rev | Feed per minute :<br>0.01 to 4000 inch/min<br>Feed per revolution<br>0.000001 to 9.999999<br>inch/rev |
| Incremental feed            | 0.0001, 0.001, 0.01, 0.1<br>inch/step                                                                 | 0.00001, 0.0001, 0.001,<br>0.01 inch/step                                                             |
| Tool compensation           | 0 to ±99.9999 inch                                                                                    | 0 to ±99.9999 inch                                                                                    |
| Backlash compensation       | 0 to ±0.255 mm                                                                                        | 0 to ±0.255 mm                                                                                        |
| Dwell time                  | 0 to 99999.999 sec                                                                                    | 0 to 9999.9999 sec                                                                                    |

● In case of inch input, feed screw is inch

|                             | Increment system                                                                                      |                                                                                                       |
|-----------------------------|-------------------------------------------------------------------------------------------------------|-------------------------------------------------------------------------------------------------------|
|                             | IS-B                                                                                                  | IS-C                                                                                                  |
| Least input increment       | 0.0001 inch                                                                                           | 0.00001 inch                                                                                          |
| Least command increment     | X : 0.00005 inch<br>Z : 0.0001 inch                                                                   | X : 0.000005 inch<br>Z : 0.00001 inch                                                                 |
| Max. programmable dimension | ±9999.9999 inch                                                                                       | ±999.99999 inch                                                                                       |
| Max. rapid traverse *1      | 9600 inch/min                                                                                         | 4000 inch/min                                                                                         |
| Feedrate range *1           | Feed per minute :<br>0.01 to 9600 inch/min<br>Feed per revolution<br>0.000001 to 9.999999<br>inch/rev | Feed per minute :<br>0.01 to 4000 inch/min<br>Feed per revolution<br>0.000001 to 9.999999<br>inch/rev |
| Incremental feed            | 0.0001, 0.001, 0.01, 0.1<br>inch/step                                                                 | 0.00001, 0.0001, 0.001,<br>0.01 inch/step                                                             |
| Tool compensation           | 0 to ±99.9999 inch                                                                                    | 0 to ±99.9999 inch                                                                                    |
| Backlash compensation       | 0 to ±0.0255 inch                                                                                     | 0 to ±0.0255 inch                                                                                     |
| Dwell time                  | 0 to 99999.999 sec                                                                                    | 0 to 9999.9999 sec                                                                                    |

● In case of millimeter input, feed screw is inch

|                             | Increment system                                                                               |                                                                                                |
|-----------------------------|------------------------------------------------------------------------------------------------|------------------------------------------------------------------------------------------------|
|                             | IS-B                                                                                           | IS-C                                                                                           |
| Least input increment       | 0.001 mm                                                                                       | 0.0001 mm                                                                                      |
| Least command increment     | X : 0.00005 inch<br>Z : 0.0001 inch                                                            | X : 0.000005 inch<br>Z : 0.00001 inch                                                          |
| Max. programmable dimension | ±99999.999 mm                                                                                  | ±9999.9999 mm                                                                                  |
| Max. rapid traverse *1      | 9600 inch/min                                                                                  | 960 inch/min                                                                                   |
| Feedrate range *1           | Feed per minute :<br>1 to 240000 mm/min<br>Feed per revolution<br>0.0001 to 500.0000<br>mm/rev | Feed per minute :<br>1 to 100000 mm/min<br>Feed per revolution<br>0.0001 to 500.0000<br>mm/rev |
| Incremental feed            | 0.001, 0.01, 0.1, 1mm/step                                                                     | 0.0001, 0.001, 0.01, 0.1<br>mm/step                                                            |
| Tool compensation           | 0 to ±999.999 mm                                                                               | 0 to ±999.9999 mm                                                                              |
| Backlash compensation       | 0 to ±0.0255 inch                                                                              | 0 to ±0.0255 inch                                                                              |
| Dwell time                  | 0 to 99999.999 sec                                                                             | 0 to 9999.9999 sec                                                                             |

**Rotation axis**

|                             | Increment system            |                                   |
|-----------------------------|-----------------------------|-----------------------------------|
|                             | IS-B                        | IS-C                              |
| Least input increment       | 0.001 deg                   | 0.0001 deg                        |
| Least command increment     | ±0.001 deg                  | ±0.0001 deg                       |
| Max. programmable dimension | ±99999.999 deg              | ±9999.9999 deg                    |
| Max. rapid traverse *1      | 240000 deg/min              | 100000 deg/min                    |
| Feedrate range *1           | 1 to 240000 deg/min         | 1 to 100000 deg/min               |
| Incremental feed            | 0.001, 0.01, 0.1, 1deg/step | 0.0001, 0.001, 0.01, 0.1 deg/step |
| Backlash compensation       | 0 to ±0.255 deg             | 0 to ±0.255 deg                   |

**NOTE**

\*1 The feedrate range shown above are limitations depending on CNC interpolation capacity.

As a whole system, limitations depending on servo system must also be considered.

# D NOMOGRAPHS



# D.1 INCORRECT THREADED LENGTH

The leads of a thread are generally incorrect in  $\delta_1$  and  $\delta_2$ , as shown in Fig. D.1 (a), due to automatic acceleration and deceleration. Thus distance allowances must be made to the extent of  $\delta_1$  and  $\delta_2$  in the program.

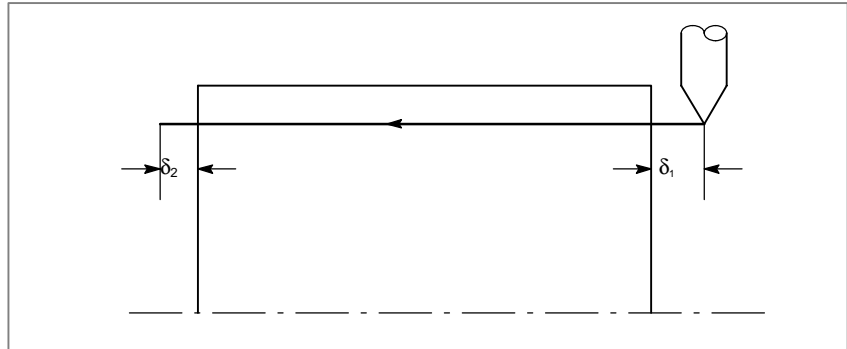

Fig. D.1 (a) Incorrect thread position

## Explanations

### • How to determine $\delta_2$

$$\delta_2 = T_1 V \text{ (mm) } \dots\dots\dots (1)$$

$$V = \frac{1}{60} RL$$

$T_1$  : Time constant of servo system (sec)  
 $V$  : Cutting speed (mm/sec)  
 $R$  : Spindle speed (rpm)  
 $L$  : Thread feed (mm)

Time constant  $T_1$  (sec) of the servo system: Usually 0.033 s.

### • How to determine $\delta_1$

$$\delta_1 = \{t - T_1 + T_1 \exp(-\frac{t}{T_1})\} V \dots\dots\dots (2)$$

$$a = \exp(-\frac{t}{T_1}) \dots\dots\dots (3)$$

$T_1$  : Time constant of servo system (sec)  
 $V$  : Cutting speed (mm/sec)

Time constant  $T_1$  (sec) of the servo system: Usually 0.033 s.

The lead at the beginning of thread cutting is shorter than the specified lead  $L$ , and the allowable lead error is  $\Delta L$ . Then as follows.

$$a = \frac{\Delta L}{L}$$

When the value of  $H\alpha I$  is determined, the time lapse until the thread accuracy is attained. The time  $HtI$  is substituted in (2) to determine  $\delta_1$ : Constants  $V$  and  $T_1$  are determined in the same way as for  $\delta_2$ . Since the calculation of  $\delta_1$  is rather complex, a nomography is provided on the following pages.

● **How to use nomograph**

First specify the class and the lead of a thread. The thread accuracy,  $\alpha$ , will be obtained at (1), and depending on the time constant of cutting feed acceleration/ deceleration, the  $\delta_1$  value when  $V = 10\text{mm/s}$  will be obtained at (2). Then, depending on the speed of thread cutting,  $\delta_1$  for speed other than  $10\text{mm/s}$  can be obtained at (3).

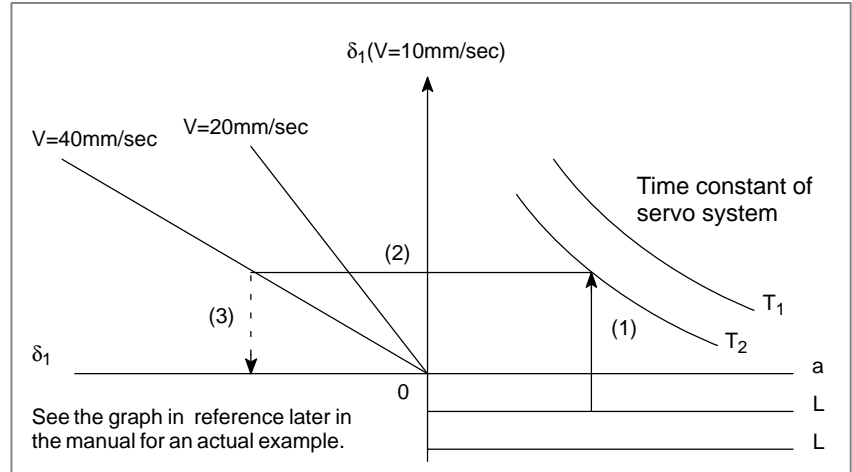

**Fig. D.1 (b) Nomograph**

**NOTE**

The equations for  $\delta_1$ , and  $\delta_2$  are for when the acceleration/deceleration time constant for cutting feed is 0.

## D.2 SIMPLE CALCULATION OF INCORRECT THREAD LENGTH

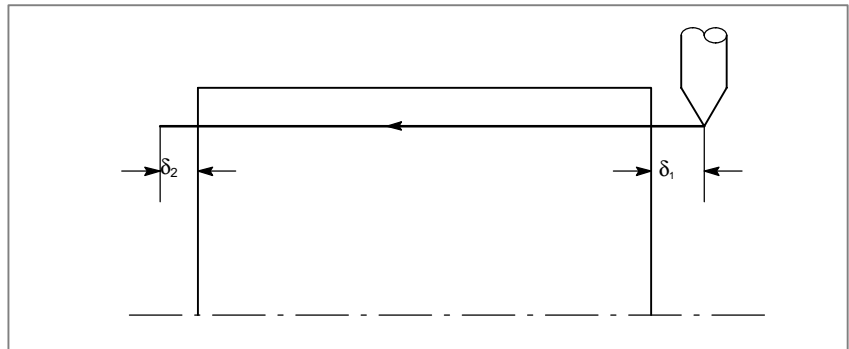

Fig. D.2 Incorrect threaded portion

### Explanations

- How to determine  $\delta_2$

$$\delta_2 = \frac{LR}{1800 * } \text{ (mm)}$$

R : Spindle speed ( $\text{min}^{-1}$ )  
L : Thread lead (mm)

\* When time constant T of the servo system is 0.033 s.

- How to determine  $\delta_1$

$$\delta_1 = \frac{LR}{1800 * } (-1 - \ln a) \text{ (mm)}$$

$$= \delta_2 (-1 - \ln a) \text{ (mm)}$$

R : Spindle speed ( $\text{min}^{-1}$ )  
L : Thread lead (mm)

\* When time constant T of the servo system is 0.033 s.

Following a is a permitted value of thread.

| a     | -1 - ln a |
|-------|-----------|
| 0.005 | 4.298     |
| 0.01  | 3.605     |
| 0.015 | 3.200     |
| 0.02  | 2.912     |

### Examples

$$R = 350 \text{ min}^{-1}$$

$$L = 1 \text{ mm}$$

$$a = 0.01 \quad \text{then}$$

$$\delta_2 = \frac{350 \times 1}{1800} = 0.194 \text{ (mm)}$$

$$\delta_1 = \delta_2 \times 3.605 = 0.701 \text{ (mm)}$$



● Reference

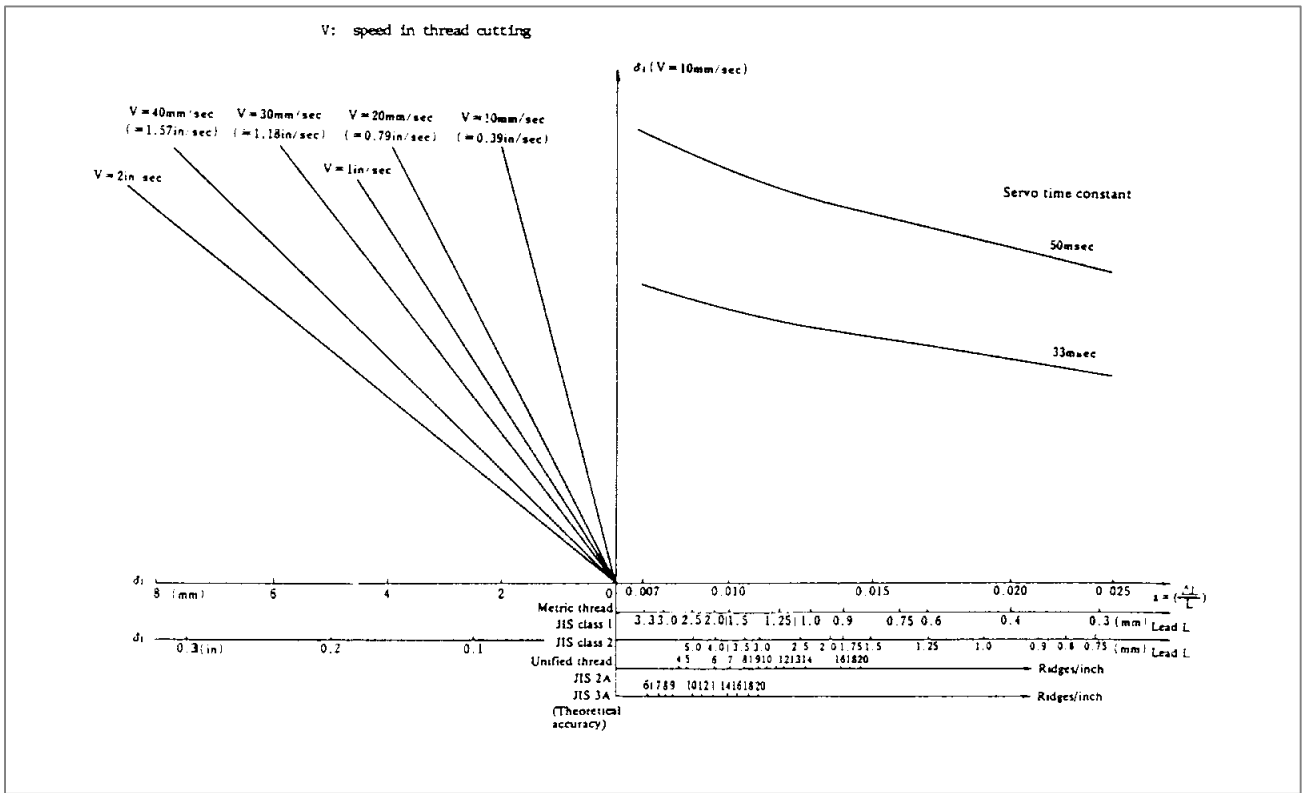

Nomograph for obtaining approach distance  $\delta_1$

### D.3 TOOL PATH AT CORNER

When servo system delay (by exponential acceleration/deceleration at cutting or caused by the positioning system when a servo motor is used) is accompanied by cornering, a slight deviation is produced between the tool path (tool center path) and the programmed path as shown in Fig. D.3 (a).

Time constant  $T_1$  of the exponential acceleration/deceleration is fixed to 0.

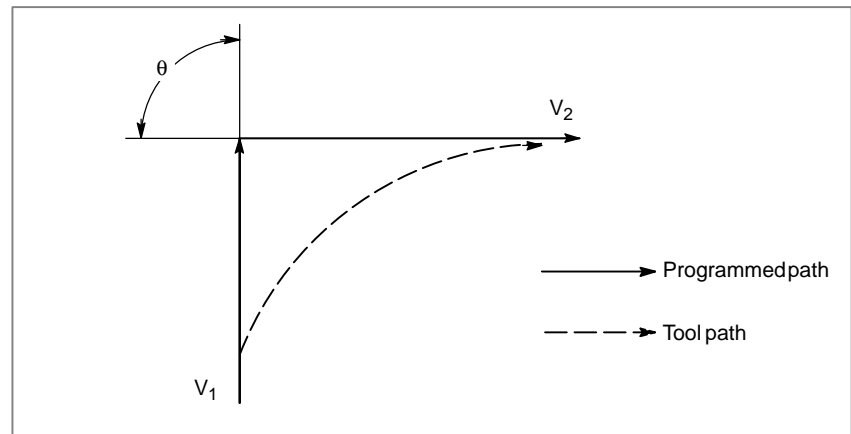

**Fig. D.3 (a) Slight deviation between the tool path and the programmed path**

This tool path is determined by the following parameters:

- Feedrate ( $V_1, V_2$ )
- Corner angle ( $\theta$ )
- Exponential acceleration / deceleration time constant ( $T_1$ ) at cutting ( $T_1 = 0$ )
- Presence or absence of buffer register.

The above parameters are used to theoretically analyze the tool path and above tool path is drawn with the parameter which is set as an example. When actually programming, the above items must be considered and programming must be performed carefully so that the shape of the workpiece is within the desired precision.

In other words, when the shape of the workpiece is not within the theoretical precision, the commands of the next block must not be read until the specified feedrate becomes zero. The dwell function is then used to stop the machine for the appropriate period.

## Analysis

The tool path shown in Fig. D.3 (b) is analyzed based on the following conditions:

Feedrate is constant at both blocks before and after cornering.

The controller has a buffer register. (The error differs with the reading speed of the tape reader, number of characters of the next block, etc.)

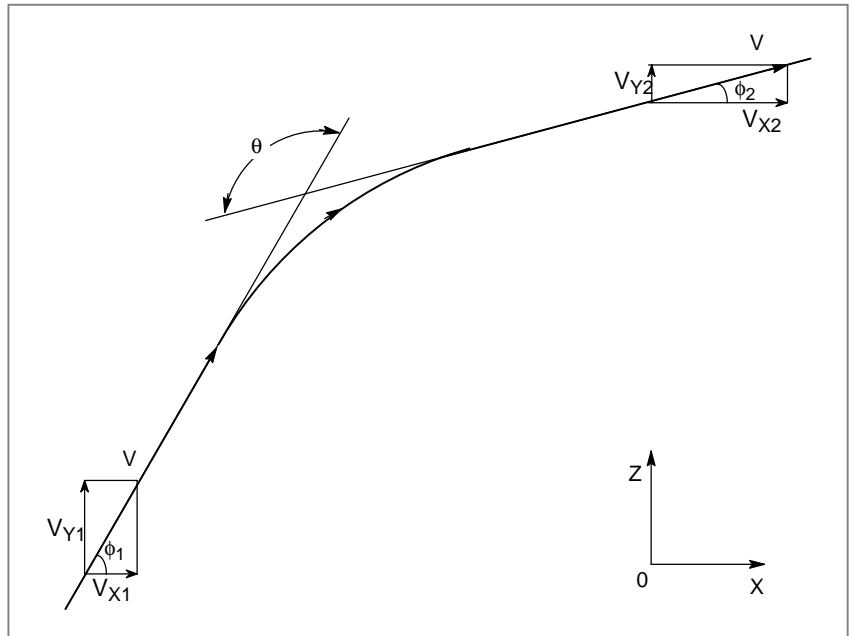

Fig. D.3 (b) Example of tool path

- Description of conditions and symbols

$$V_{X1} = V \cos \phi_1$$

$$V_{Y1} = V \sin \phi_1$$

$$V_{X2} = V \cos \phi_2$$

$$V_{Y2} = V \sin \phi_2$$

$V$  : Feedrate at both blocks before and after cornering

$V_{X1}$  : X-axis component of feedrate of preceding block

$V_{Y1}$  : Y-axis component of feedrate of preceding block

$V_{X2}$  : X-axis component of feedrate of following block

$V_{Y2}$  : Y-axis component of feedrate of following block

$\theta$  : Corner angle

$\phi_1$  : Angle formed by specified path direction of preceding block and X-axis

$\phi_2$  : Angle formed by specified path direction of following block and X-axis

• Initial value calculation

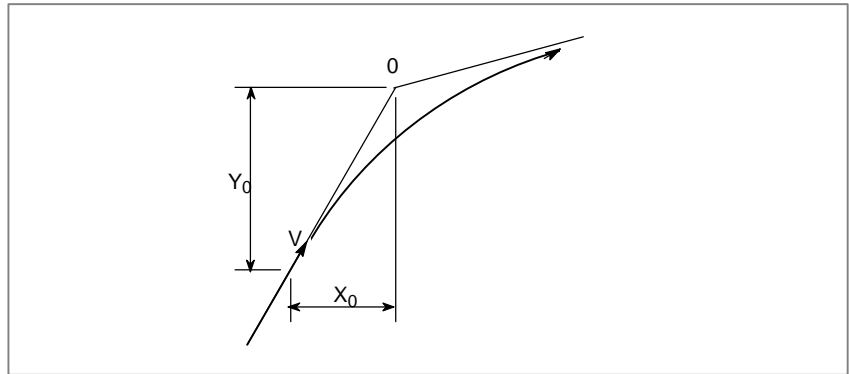

Fig. D.3 (c) Initial value

The initial value when cornering begins, that is, the X and Y coordinates at the end of command distribution by the controller, is determined by the feedrate and the positioning system time constant of the servo motor.

$$X_0 = V_{x1}(T_1 + T_2)$$

$$Y_0 = V_{y1}(T_1 + T_2)$$

$T_1$ : Exponential acceleration / deceleration time constant. ( $T=0$ )  
 $T_2$ : Time constant of positioning system (Inverse of position loop gain)

• Analysis of corner tool path

The equations below represent the feedrate for the corner section in X-axis direction and Y-axis direction.

$$V_x(t) = (V_{x2}-V_{x1})\left[1-\frac{V_{x1}}{T_1-T_2}\left\{T_1 \exp\left(-\frac{t}{T_1}\right)-T_2 \exp\left(-\frac{t}{T_2}\right)\right\}+V_{x1}\right]$$

$$= V_{x2}\left[1-\frac{V_{x1}}{T_1-T_2}\left\{T_1 \exp\left(-\frac{t}{T_1}\right)-T_2 \exp\left(-\frac{t}{T_2}\right)\right\}\right]$$

$$V_y(t) = \frac{V_{y1}-V_{y2}}{T_1-T_2}\left\{T_1 \exp\left(-\frac{t}{T_1}\right)-T_2 \exp\left(-\frac{t}{T_2}\right)\right\}+V_{y2}$$

Therefore, the coordinates of the tool path at time  $t$  are calculated from the following equations:

$$X(t) = \int_0^t V_x(t)dt - X_0$$

$$= \frac{V_{x2}-V_{x1}}{T_1-T_2}\left\{T_1^2 \exp\left(-\frac{t}{T_1}\right)-T_2^2 \exp\left(-\frac{t}{T_2}\right)\right\}-V_{x2}(T_1 + T_2 - t)$$

$$Y(t) = \int_0^t V_y(t)dt - Y_0$$

$$= \frac{V_{y2}-V_{y1}}{T_1-T_2}\left\{T_1^2 \exp\left(-\frac{t}{T_1}\right)-T_2^2 \exp\left(-\frac{t}{T_2}\right)\right\}-V_{y2}(T_1 + T_2 - t)$$

### D.4 RADIUS DIRECTION ERROR AT CIRCLE CUTTING

When a servo motor is used, the positioning system causes an error between input commands and output results. Since the tool advances along the specified segment, an error is not produced in linear interpolation. In circular interpolation, however, radial errors may be produced, specially for circular cutting at high speeds. This error can be obtained as follows:

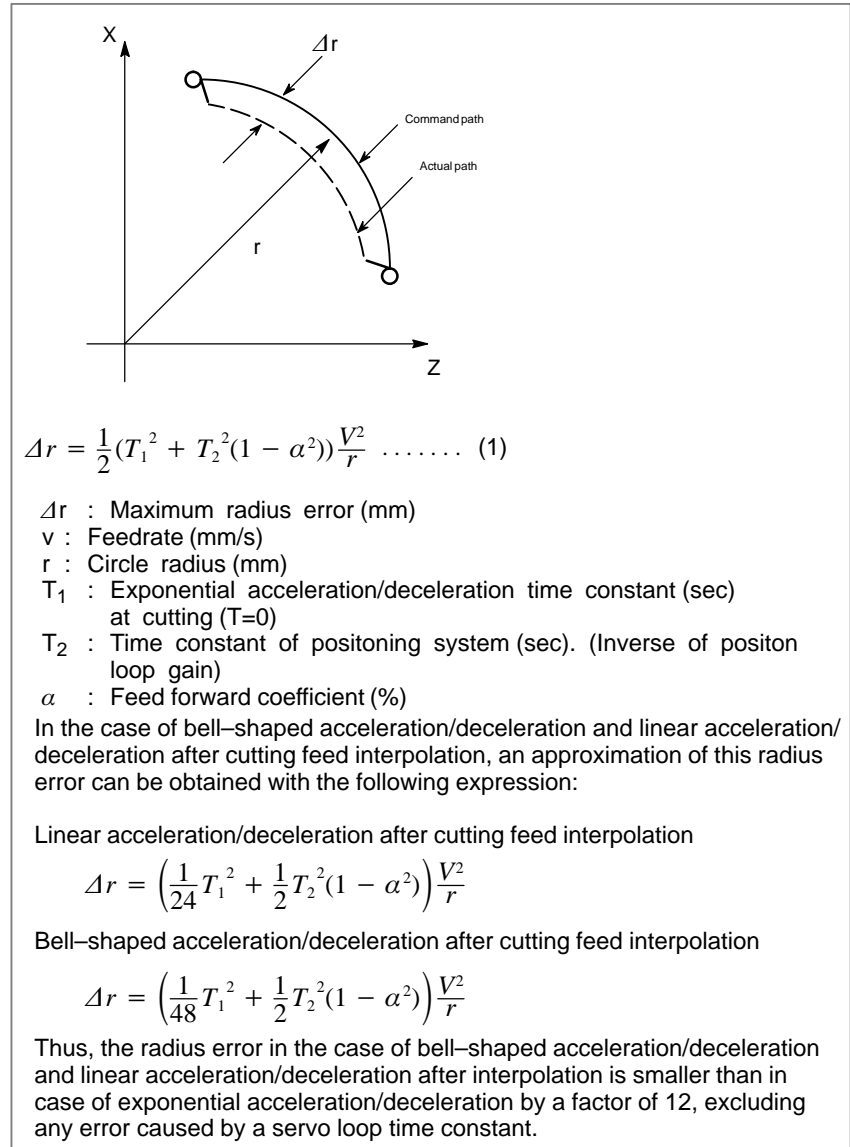

**Fig. D.4 (a) Radius direction error of circular cutting**

Since the machining radius  $r$  (mm) and allowable error  $\Delta r$  (mm) of the workpiece is given in actual machining, the allowable limit feedrate  $v$  (mm/sec) is determined by equation (1).

Since the acceleration/deceleration time constant at cutting which is set by this equipment varies with the machine tool, refer to the manual issued by the machine tool builder.

# E STATUS WHEN TURNING POWER ON, WHEN CLEAR AND WHEN RESET

Parameter 3402 (CLR) is used to select whether resetting the CNC places it in the cleared state or in the reset state (0: reset state/1: cleared state).

The symbols in the tables below mean the following :

○:The status is not changed or the movement is continued.

×:The status is cancelled or the movement is interrupted.

| Item                  |                                       | When turning power on                                                                                                 | Cleared                                        | Reset                          |
|-----------------------|---------------------------------------|-----------------------------------------------------------------------------------------------------------------------|------------------------------------------------|--------------------------------|
| Setting data          | Offset value                          | ○                                                                                                                     | ○                                              | ○                              |
|                       | Data set by the MDI setting operation | ○                                                                                                                     | ○                                              | ○                              |
|                       | Parameter                             | ○                                                                                                                     | ○                                              | ○                              |
| Various data          | Programs in memory                    | ○                                                                                                                     | ○                                              | ○                              |
|                       | Contents in the buffer storage        | ×                                                                                                                     | ×                                              | ○ : MDI mode<br>× : Other mode |
|                       | Display of sequence number            | ○                                                                                                                     | ○ (Note 1)                                     | ○ (Note 1)                     |
|                       | One shot G code                       | ×                                                                                                                     | ×                                              | ×                              |
|                       | Modal G code                          | Initial G codes.<br>(The G20 and G21 codes return to the same state they were in when the power was last turned off.) | Initial G codes.<br>(G20/G21 are not changed.) | ○                              |
|                       | F                                     | Zero                                                                                                                  | Zero                                           | ○                              |
|                       | S, T, M                               | ×                                                                                                                     | ○                                              | ○                              |
|                       | K (Number of repeats)                 | ×                                                                                                                     | ×                                              | ×                              |
| Work coordinate value |                                       | Zero                                                                                                                  | ○                                              | ○                              |

| Item                |                                             | When turning power on                         | Cleared                                       | Reset                                                           |
|---------------------|---------------------------------------------|-----------------------------------------------|-----------------------------------------------|-----------------------------------------------------------------|
| Action in operation | Movement                                    | ×                                             | ×                                             | ×                                                               |
|                     | Dwell                                       | ×                                             | ×                                             | ×                                                               |
|                     | Issuance of M, S and T codes                | ×                                             | ×                                             | ×                                                               |
|                     | Tool offset                                 | ×                                             | Depending on parameter LVK(No.5003#6)         | ○ : MDI mode<br>Other modes depend on parameter LVK(No.5003#6). |
|                     | Tool nose radius compensation               | ×                                             | ×                                             | ○ : MDI mode<br>× : Other modes                                 |
|                     | Storing called sub-program number           | ×                                             | × (Note 2)                                    | ○ : MDI mode<br>× : Other modes (Note 2)                        |
| Output signals      | CNC alarm signal AL                         | Extinguish if there is no cause for the alarm | Extinguish if there is no cause for the alarm | Extinguish if there is no cause for the alarm                   |
|                     | Reference position return completion LED    | ×                                             | ○ (× : Emergency stop)                        | ○ (× : Emergency stop)                                          |
|                     | S, T and B codes                            | ×                                             | ○                                             | ○                                                               |
|                     | M code                                      | ×                                             | ×                                             | ×                                                               |
|                     | M, S and T strobe signals                   | ×                                             | ×                                             | ×                                                               |
|                     | Spindle revolution signal (S analog signal) | ×                                             | ○                                             | ○                                                               |
|                     | CNC ready signal MA                         | ON                                            | ○                                             | ○                                                               |
|                     | Servo ready signal SA                       | ON (When other than servo alarm)              | ON (When other than servo alarm)              | ON (When other than servo alarm)                                |
|                     | Cycle start LED (STL)                       | ×                                             | ×                                             | ×                                                               |
|                     | Feed hold LED (SPL)                         | ×                                             | ×                                             | ×                                                               |

**NOTE**

- 1 When heading is performed, the main program number is displayed.
- 2 When a reset is performed during execution of a subprogram, control returns the main program. Execution cannot be started from the middle of the subprogram.

# F CHARACTER-TO-CODES CORRESPONDENCE TABLE

| Character | Code | Comment | Character | Code | Comment              |
|-----------|------|---------|-----------|------|----------------------|
| A         | 065  |         | 6         | 054  |                      |
| B         | 066  |         | 7         | 055  |                      |
| C         | 067  |         | 8         | 056  |                      |
| D         | 068  |         | 9         | 057  |                      |
| E         | 069  |         |           | 032  | Space                |
| F         | 070  |         | !         | 033  | Exclamation mark     |
| G         | 071  |         | "         | 034  | Quotation mark       |
| H         | 072  |         | #         | 035  | Hash sign            |
| I         | 073  |         | \$        | 036  | Dollar sign          |
| J         | 074  |         | %         | 037  | Percent              |
| K         | 075  |         | &         | 038  | Ampersand            |
| L         | 076  |         | '         | 039  | Apostrophe           |
| M         | 077  |         | (         | 040  | Left parenthesis     |
| N         | 078  |         | )         | 041  | Right parenthesis    |
| O         | 079  |         | *         | 042  | Asterisk             |
| P         | 080  |         | +         | 043  | Plus sign            |
| Q         | 081  |         | ,         | 044  | Comma                |
| R         | 082  |         | -         | 045  | Minus sign           |
| S         | 083  |         | .         | 046  | Period               |
| T         | 084  |         | /         | 047  | Slash                |
| U         | 085  |         | :         | 058  | Colon                |
| V         | 086  |         | ;         | 059  | Semicolon            |
| W         | 087  |         | <         | 060  | Left angle bracket   |
| X         | 088  |         | =         | 061  | Equal sign           |
| Y         | 089  |         | >         | 062  | Right angle bracket  |
| Z         | 090  |         | ?         | 063  | Question mark        |
| 0         | 048  |         | @         | 064  | HAAt mark            |
| 1         | 049  |         | [         | 091  | Left square bracket  |
| 2         | 050  |         | ^         | 092  |                      |
| 3         | 051  |         | ¥         | 093  | Yen sign             |
| 4         | 052  |         | ]         | 094  | Right square bracket |
| 5         | 053  |         | _         | 095  | Underscore           |



# G ALARM LIST

## 1) Program errors (P/S alarm)

| Number | Message                      | Contents                                                                                                                                                                                                                                                                                                                                                                                                                 |
|--------|------------------------------|--------------------------------------------------------------------------------------------------------------------------------------------------------------------------------------------------------------------------------------------------------------------------------------------------------------------------------------------------------------------------------------------------------------------------|
| 000    | PLEASE TURN OFF POWER        | A parameter which requires the power off was input, turn off power.                                                                                                                                                                                                                                                                                                                                                      |
| 001    | TH PARITY ALARM              | TH alarm (A character with incorrect parity was input).<br>Correct the tape.                                                                                                                                                                                                                                                                                                                                             |
| 002    | TV PARITY ALARM              | TV alarm (The number of characters in a block is odd). This alarm will be generated only when the TV check is effective.                                                                                                                                                                                                                                                                                                 |
| 003    | TOO MANY DIGITS              | Data exceeding the maximum allowable number of digits was input. (Refer to the item of max. programmable dimensions.)                                                                                                                                                                                                                                                                                                    |
| 004    | ADDRESS NOT FOUND            | A numeral or the sign “ - ” was input without an address at the beginning of a block. Modify the program .                                                                                                                                                                                                                                                                                                               |
| 005    | NO DATA AFTER ADDRESS        | The address was not followed by the appropriate data but was followed by another address or EOB code. Modify the program.                                                                                                                                                                                                                                                                                                |
| 006    | ILLEGAL USE OF NEGATIVE SIGN | Sign “ - ” input error (Sign “ - ” was input after an address with which it cannot be used. Or two or more “ - ” signs were input.)<br>Modify the program.                                                                                                                                                                                                                                                               |
| 007    | ILLEGAL USE OF DECIMAL POINT | Decimal point “ . ” input error (A decimal point was input after an address with which it can not be used. Or two decimal points were input.)<br>Modify the program.                                                                                                                                                                                                                                                     |
| 009    | ILLEGAL ADDRESS INPUT        | Unusable character was input in significant area.<br>Modify the program.                                                                                                                                                                                                                                                                                                                                                 |
| 010    | IMPROPER G-CODE              | An unusable G code or G code corresponding to the function not provided is specified. Modify the program.                                                                                                                                                                                                                                                                                                                |
| 011    | NO FEEDRATE COMMANDED        | Feedrate was not commanded to a cutting feed or the feedrate was inadequate. Modify the program.                                                                                                                                                                                                                                                                                                                         |
| 014    | ILLEGAL LEAD COMMAND         | In variable lead threading, the lead incremental and decremental outputted by address K exceed the maximum command value or a command such that the lead becomes a negative value is given.<br>Modify the program.                                                                                                                                                                                                       |
| 015    | TOO MANY AXES COMMANDED      | An attempt has been made to move the tool along more than the maximum number of simultaneously controlled axes. Alternatively, no axis movement command or an axis movement command for two or more axes has been specified in the block containing the command for skip using the torque limit signal (G31 P99/98). The command must be accompanied with an axis movement command for a single axis, in the same block. |
| 020    | OVER TOLERANCE OF RADIUS     | In circular interpolation (G02 or G03), difference of the distance between the start point and the center of an arc and that between the end point and the center of the arc exceeded the value specified in parameter No. 3410.                                                                                                                                                                                         |
| 021    | ILLEGAL PLANE AXIS COMMANDED | An axis not included in the selected plane (by using G17, G18, G19) was commanded in circular interpolation. Modify the program.                                                                                                                                                                                                                                                                                         |
| 022    | CIRCULAR INTERPOLATION       | In circular interpolation, radius R, or the distance between the start point and the center of the arc, I, J, or K, has not been specified.                                                                                                                                                                                                                                                                              |

| Number | Message                              | Contents                                                                                                                                                                                                                     |
|--------|--------------------------------------|------------------------------------------------------------------------------------------------------------------------------------------------------------------------------------------------------------------------------|
| 023    | ILLEGAL RADIUS COMMAND               | In circular interpolation by radius designation, negative value was commanded for address R. Modify the program.                                                                                                             |
| 028    | ILLEGAL PLANE SELECT                 | In the plane selection command, two or more axes in the same direction are commanded.<br>Modify the program.                                                                                                                 |
| 029    | ILLEGAL OFFSET VALUE                 | The offset values specified by T code is too large.<br>Modify the program.                                                                                                                                                   |
| 030    | ILLEGAL OFFSET NUMBER                | The offset number in T function specified for tool offset is too large.<br>Modify the program.                                                                                                                               |
| 031    | ILLEGAL P COMMAND IN G10             | In setting an offset amount by G10, the offset number following address P was excessive or it was not specified.<br>Modify the program.                                                                                      |
| 032    | ILLEGAL OFFSET VALUE IN G10          | In setting an offset amount by G10 or in writing an offset amount by system variables, the offset amount was excessive.                                                                                                      |
| 033    | NO SOLUTION AT NRC                   | A point of intersection cannot be determined for tool nose radius compensation. Modify the program.                                                                                                                          |
| 034    | NO CIRC ALLOWED IN ST-UP<br>/EXT BLK | The start up or cancel was going to be performed in the G02 or G03 mode in tool nose radius compensation. Modify the program.                                                                                                |
| 035    | CAN NOT COMMANDED G31                | Skip cutting (G31) was specified in tool nose radius compensation mode. Modify the program.                                                                                                                                  |
| 037    | CAN NOT CHANGE PLANE IN NRC          | The offset plane is switched in tool nose radius compensation.<br>Modify the program.                                                                                                                                        |
| 038    | INTERFERENCE IN CIRCULAR<br>BLOCK    | Overcutting will occur in tool nose radius compensation because the arc start point or end point coincides with the arc center.<br>Modify the program.                                                                       |
| 039    | CHF/CNR NOT ALLOWED IN NRC           | Chamfering or corner R was specified with a start-up, a cancel, or switching between G41 and G42 in tool nose radius compensation. The program may cause overcutting to occur in chamfering or corner R. Modify the program. |
| 040    | INTERFERENCE IN G90/G94<br>BLOCK     | Overcutting will occur in tool nose radius compensation in canned cycle G90 or G94. Modify the program.                                                                                                                      |
| 041    | INTERFERENCE IN NRC                  | Overcutting will occur in tool nose radius compensation.<br>Modify the program.                                                                                                                                              |
| 046    | ILLEGAL REFERENCE RETURN<br>COMMAND  | Other than P2, P3 and P4 are commanded for 2nd, 3rd and 4th reference position return command.                                                                                                                               |
| 047    | ILLEGAL AXIS SELECT                  | Two or more parallel axes (in parallel with a basic axis) have been specified upon start-up of three-dimensional tool compensation or three-dimensional coordinate conversion.<br>Modify the program.                        |
| 048    | BASIC 3 AXIS NOT FOUND               | Start-up of three-dimensional tool compensation or three-dimensional coordinate conversion has been attempted, but the three basic axes used when Xp, Yp, or Zp is omitted are not set in parameter No. 1022.                |
| 050    | CHF/CNR NOT ALLOWED IN THRD<br>BLK   | Chamfering or corner R is commanded in the thread cutting block.<br>Modify the program.                                                                                                                                      |
| 051    | MISSING MOVE AFTER CHF/CNR           | Improper movement or the move distance was specified in the block next to the chamfering or corner R block.<br>Modify the program.                                                                                           |
| 052    | CODE IS NOT G01 AFTER<br>CHF/CNR     | The block next to the chamfering or corner R block is not G01.<br>Modify the program.                                                                                                                                        |
| 053    | TOO MANY ADDRESS<br>COMMANDS         | In the chamfering and corner R commands, two or more of I, K and R are specified. Otherwise, the character after a comma(",") is not C or R in direct drawing dimensions programming. Modify the program.                    |

| Number | Message                          | Contents                                                                                                                                                                                                                                                                                                                                                                                                                                                                                                                                                                                                                                                                                                                                                                                                                                                                    |
|--------|----------------------------------|-----------------------------------------------------------------------------------------------------------------------------------------------------------------------------------------------------------------------------------------------------------------------------------------------------------------------------------------------------------------------------------------------------------------------------------------------------------------------------------------------------------------------------------------------------------------------------------------------------------------------------------------------------------------------------------------------------------------------------------------------------------------------------------------------------------------------------------------------------------------------------|
| 054    | NO TAPER ALLOWED AFTER CHF/CNR   | A block in which chamfering in the specified angle or the corner R was specified includes a taper command. Modify the program.                                                                                                                                                                                                                                                                                                                                                                                                                                                                                                                                                                                                                                                                                                                                              |
| 055    | MISSING MOVE VALUE IN CHF/CNR    | In chamfering or corner R block, the move distance is less than chamfer or corner R amount.                                                                                                                                                                                                                                                                                                                                                                                                                                                                                                                                                                                                                                                                                                                                                                                 |
| 056    | NO END POINT & ANGLE IN CHF/CNR  | Neither the end point nor angle is specified in the command for the block next to that for which only the angle is specified (A). In the chamfering common, I(K) is commanded for the X(Z) axis.                                                                                                                                                                                                                                                                                                                                                                                                                                                                                                                                                                                                                                                                            |
| 057    | NO SOLUTION OF BLOCK END         | Block end point is not calculated correctly in direct dimension drawing programming.                                                                                                                                                                                                                                                                                                                                                                                                                                                                                                                                                                                                                                                                                                                                                                                        |
| 058    | END POINT NOT FOUND              | Block end point is not found in direct dimension drawing programming.                                                                                                                                                                                                                                                                                                                                                                                                                                                                                                                                                                                                                                                                                                                                                                                                       |
| 059    | PROGRAM NUMBER NOT FOUND         | In an external program number search or external workpiece number search, a specified program number was not found. Otherwise, a program specified for searching is being edited in background processing. Otherwise, a program specified by an one-touch macro call is not registered in memory. Check the program number and external signal. Or discontinue the background editing.                                                                                                                                                                                                                                                                                                                                                                                                                                                                                      |
| 060    | SEQUENCE NUMBER NOT FOUND        | Commanded sequence number was not found in the sequence number search. Check the sequence number.                                                                                                                                                                                                                                                                                                                                                                                                                                                                                                                                                                                                                                                                                                                                                                           |
| 061    | ADDRESS P/Q NOT FOUND IN G70-G73 | Address P or Q is not specified in G70, G71, G72, or G73 command. Modify the program.                                                                                                                                                                                                                                                                                                                                                                                                                                                                                                                                                                                                                                                                                                                                                                                       |
| 062    | ILLEGAL COMMAND IN G71-G76       | <ol style="list-style-type: none"> <li>1 The depth of cut in G71 or G72 is zero or negative value.</li> <li>2 The repetitive count in G73 is zero or negative value.</li> <li>3 The negative value is specified to <math>\Delta i</math> or <math>\Delta k</math> is zero in G74 or G75.</li> <li>4 A value other than zero is specified to address U or W, though <math>\Delta i</math> or <math>\Delta k</math> is zero in G74 or G75.</li> <li>5 A negative value is specified to <math>\Delta d</math>, though the relief direction in G74 or G75 is determined.</li> <li>6 Zero or a negative value is specified to the height of thread or depth of cut of first time in G76.</li> <li>7 The specified minimum depth of cut in G76 is greater than the height of thread.</li> <li>8 An unusable angle of tool tip is specified in G76.</li> </ol> Modify the program. |
| 063    | SEQUENCE NUMBER NOT FOUND        | The sequence number specified by address P in G70, G71, G72, or G73 command cannot be searched. Modify the program.                                                                                                                                                                                                                                                                                                                                                                                                                                                                                                                                                                                                                                                                                                                                                         |
| 064    | SHAPE PROGRAM NOT MONOTONOUSLY   | A target shape which is not monotonous increase or decrease was specified in a repetitive canned cycle (G71 or G72).                                                                                                                                                                                                                                                                                                                                                                                                                                                                                                                                                                                                                                                                                                                                                        |
| 065    | ILLEGAL COMMAND IN G71-G73       | <ol style="list-style-type: none"> <li>1 G00 or G01 is not commanded at the block with the sequence number which is specified by address P in G71, G72, or G73 command.</li> <li>2 Address Z(W) or X(U) was commanded in the block with a sequence number which is specified by address P in G71 or G72, respectively.</li> </ol> Modify the program.                                                                                                                                                                                                                                                                                                                                                                                                                                                                                                                       |
| 066    | IMPROPER G-CODE IN G71-G73       | An unallowable G code was commanded between two blocks specified by address P in G71, G72, or G73. Modify the program.                                                                                                                                                                                                                                                                                                                                                                                                                                                                                                                                                                                                                                                                                                                                                      |
| 067    | CAN NOT OPERATE IN MDI MODE      | G70, G71, G72, or G73 command with address P and Q was specified. Modify the program.                                                                                                                                                                                                                                                                                                                                                                                                                                                                                                                                                                                                                                                                                                                                                                                       |
| 069    | FORMAT ERROR IN G70-G73          | The final move command in the blocks specified by P and Q of G70, G71, G72, or G73 ended with chamfering or corner R.                                                                                                                                                                                                                                                                                                                                                                                                                                                                                                                                                                                                                                                                                                                                                       |

| Number | Message                            | Contents                                                                                                                                                                                                                                                                                                                                     |
|--------|------------------------------------|----------------------------------------------------------------------------------------------------------------------------------------------------------------------------------------------------------------------------------------------------------------------------------------------------------------------------------------------|
| 070    | NO PROGRAM SPACE IN MEMORY         | The memory area is insufficient.<br>Delete any unnecessary programs, then retry.                                                                                                                                                                                                                                                             |
| 071    | DATA NOT FOUND                     | The address to be searched was not found. Or the program with specified program number was not found in program number search.<br>Check the data.                                                                                                                                                                                            |
| 072    | TOO MANY PROGRAMS                  | The number of programs to be stored exceeded 63 (basic), 125 (option), 200 (option), 400 (option), or 1000 (option). Delete unnecessary programs and execute program registration again.                                                                                                                                                     |
| 073    | PROGRAM NUMBER ALREADY IN USE      | The commanded program number has already been used.<br>Change the program number or delete unnecessary programs and execute program registration again.                                                                                                                                                                                      |
| 074    | ILLEGAL PROGRAM NUMBER             | The program number is other than 1 to 9999.<br>Modify the program number.                                                                                                                                                                                                                                                                    |
| 075    | PROTECT                            | An attempt was made to register a program whose number was protected.                                                                                                                                                                                                                                                                        |
| 076    | ADDRESS P NOT DEFINED              | Address P (program number) was not commanded in the block which includes an M98, G65, or G66 command. Modify the program.                                                                                                                                                                                                                    |
| 077    | SUB PROGRAM NESTING ERROR          | The subprogram was called in five folds. Modify the program.                                                                                                                                                                                                                                                                                 |
| 078    | NUMBER NOT FOUND                   | A program number or a sequence number which was specified by address P in the block which includes an M98, M99, M65 or G66 was not found. The sequence number specified by a GOTO statement was not found. Otherwise, a called program is being edited in background processing. Correct the program, or discontinue the background editing. |
| 079    | PROGRAM VERIFY ERROR               | In memory or program collation, a program in memory does not agree with that read from an external I/O device. Check both the programs in memory and those from the external device.                                                                                                                                                         |
| 080    | G37 ARRIVAL SIGNAL NOT ASSERTED    | In the automatic tool compensation function (G36, G37), the measurement position reach signal (XAE or ZAE) is not turned on within an area specified in parameter 6254 (value $\epsilon$ ).<br>This is due to a setting or operator error.                                                                                                   |
| 081    | OFFSET NUMBER NOT FOUND IN G37     | Automatic tool compensation (G36, G37) was specified without a T code. (Automatic tool compensation function) Modify the program.                                                                                                                                                                                                            |
| 082    | T-CODE NOT ALLOWED IN G37          | T code and automatic tool compensation (G36, G37) were specified in the same block. (Automatic tool compensation function) Modify the program.                                                                                                                                                                                               |
| 083    | ILLEGAL AXIS COMMAND IN G37        | In automatic tool compensation (G36, G37), an invalid axis was specified or the command is incremental. Modify the program.                                                                                                                                                                                                                  |
| 085    | COMMUNICATION ERROR                | When entering data in the memory by using Reader / Puncher interface, an overrun, parity or framing error was generated. The number of bits of input data or setting of baud rate or specification No. of I/O unit is incorrect.                                                                                                             |
| 086    | DR SIGNAL OFF                      | When entering data in the memory by using Reader / Puncher interface, the ready signal (DR) of reader / puncher was turned off.<br>Power supply of I/O unit is off or cable is not connected or a P.C.B. is defective.                                                                                                                       |
| 087    | BUFFER OVERFLOW                    | When entering data in the memory by using Reader / Puncher interface, though the read terminate command is specified, input is not interrupted after 10 characters read. I/O unit or P.C.B. is defective.                                                                                                                                    |
| 088    | G LAN FILE TRANS ERROR (CHANNEL-1) | File data transfer over the OSI-Ethernet was terminated as a result of a transfer error.                                                                                                                                                                                                                                                     |
| 089    | G LAN FILE TRANS ERROR (CHANNEL-2) | File data transfer over the OSI-Ethernet was terminated as a result of a transfer error.                                                                                                                                                                                                                                                     |

| Number | Message                          | Contents                                                                                                                                                                                                                                                                                                                                       |
|--------|----------------------------------|------------------------------------------------------------------------------------------------------------------------------------------------------------------------------------------------------------------------------------------------------------------------------------------------------------------------------------------------|
| 090    | REFERENCE RETURN INCOMPLETE      | The reference position return cannot be performed normally because the reference position return start point is too close to the reference position or the speed is too slow. Separate the start point far enough from the reference position, or specify a sufficiently fast speed for reference position return. Check the program contents. |
| 091    | REFERENCE RETURN INCOMPLETE      | In the automatic operation halt state, manual reference position return cannot be performed.                                                                                                                                                                                                                                                   |
| 092    | AXES NOT ON THE REFERENCE POINT  | The commanded axis by G27 (Reference position return check) did not return to the reference position.                                                                                                                                                                                                                                          |
| 094    | P TYPE NOT ALLOWED (COORD CHG)   | P type cannot be specified when the program is restarted. (After the automatic operation was interrupted, the coordinate system setting operation was performed.)<br>Perform the correct operation according to the operator's manual.                                                                                                         |
| 095    | P TYPE NOT ALLOWED (EXT OFS CHG) | P type cannot be specified when the program is restarted. (After the automatic operation was interrupted, the external workpiece offset amount changed.)<br>Perform the correct operation according to the operator's manual.                                                                                                                  |
| 096    | P TYPE NOT ALLOWED (WRK OFS CHG) | P type cannot be specified when the program is restarted. (After the automatic operation was interrupted, the workpiece offset amount changed.)<br>Perform the correct operation according to the operator's manual.                                                                                                                           |
| 097    | P TYPE NOT ALLOWED (AUTO EXEC)   | P type cannot be directed when the program is restarted. (After power ON, after emergency stop or P/S alarm 94 to 97 were reset, no automatic operation was performed.) Perform automatic operation.                                                                                                                                           |
| 098    | G28 FOUND IN SEQUENCE RETURN     | A command of the program restart was specified without the reference position return operation after power ON or emergency stop, and G28 was found during search.<br>Perform the reference position return.                                                                                                                                    |
| 099    | MDI EXEC NOT ALLOWED AFT. SEARCH | After completion of search in program restart, a move command is given with MDI.                                                                                                                                                                                                                                                               |
| 100    | PARAMETER WRITE ENABLE           | On the PARAMETER(SETTING) screen, PWE(parameter writing enabled) is set to 1. Set it to 0, then reset the system.                                                                                                                                                                                                                              |
| 101    | PLEASE CLEAR MEMORY              | The power turned off while rewriting the memory by program edit operation. If this alarm has occurred, press <RESET> while pressing <PROG>, and only the program being edited will be deleted.<br>Register the deleted program.                                                                                                                |
| 109    | FORMAT ERROR IN G08              | A value other than 0 or 1 was specified after P in the G08 code, or no value was specified.<br>Modify the program.                                                                                                                                                                                                                             |
| 111    | CALCULATED DATA OVERFLOW         | The result of calculation is out of the allowable range ( $-10^{47}$ to $-10^{-29}$ , 0, and $10^{-29}$ to $10^{47}$ ).                                                                                                                                                                                                                        |
| 112    | DIVIDED BY ZERO                  | Division by zero was specified. (including $\tan 90^\circ$ )<br>Modify the program.                                                                                                                                                                                                                                                            |
| 113    | IMPROPER COMMAND                 | A function which cannot be used in custom macro is commanded.<br>Modify the program.                                                                                                                                                                                                                                                           |
| 114    | FORMAT ERROR IN MACRO            | There is an error in other formats than <Formula>.<br>Modify the program.                                                                                                                                                                                                                                                                      |

| Number | Message                           | Contents                                                                                                                                                                                                                                                                                                                                                                                                                                                                                                                                                                                                                                                                                                                                                                                                                                                                 |
|--------|-----------------------------------|--------------------------------------------------------------------------------------------------------------------------------------------------------------------------------------------------------------------------------------------------------------------------------------------------------------------------------------------------------------------------------------------------------------------------------------------------------------------------------------------------------------------------------------------------------------------------------------------------------------------------------------------------------------------------------------------------------------------------------------------------------------------------------------------------------------------------------------------------------------------------|
| 115    | ILLEGAL VARIABLE NUMBER           | A value not defined as a variable number is designated in the custom macro or in high-speed cycle cutting.<br>The header contents are improper in a high speed cycle cutting. This alarm is given in the following cases:<br>1. The header corresponding to the specified machining cycle number called is not found.<br>2. The cycle connection data value is out of the allowable range (0 – 999).<br>3. The number of data in the header is out of the allowable range (0 – 32767).<br>4. The start data variable number of executable format data is out of the allowable range (#20000 – #85535).<br>5. The storing data variable number of executable format data is out of the allowable range (#85535).<br>6. The storing start data variable number of executable format data is overlapped with the variable number used in the header.<br>Modify the program. |
| 116    | WRITE PROTECTED VARIABLE          | The left side of substitution statement is a variable whose substitution is inhibited. Modify the program.                                                                                                                                                                                                                                                                                                                                                                                                                                                                                                                                                                                                                                                                                                                                                               |
| 118    | PARENTHESIS NESTING ERROR         | The nesting of bracket exceeds the upper limit (quintuple).<br>Modify the program.                                                                                                                                                                                                                                                                                                                                                                                                                                                                                                                                                                                                                                                                                                                                                                                       |
| 119    | ILLEGAL ARGUMENT                  | The SQRT argument is negative, BCD argument is negative, or other values than 0 to 9 are present on each line of BIN argument.<br>Modify the program.                                                                                                                                                                                                                                                                                                                                                                                                                                                                                                                                                                                                                                                                                                                    |
| 122    | QUADRUPLE MACRO MODAL-CALL        | A total of four macro calls and macro modal calls are nested.<br>Modify the program.                                                                                                                                                                                                                                                                                                                                                                                                                                                                                                                                                                                                                                                                                                                                                                                     |
| 123    | CAN NOT USE MACRO COMMAND IN DNC  | Macro control command is used during DNC operation.<br>Modify the program.                                                                                                                                                                                                                                                                                                                                                                                                                                                                                                                                                                                                                                                                                                                                                                                               |
| 124    | MISSING END STATEMENT             | DO – END does not correspond to 1 : 1. Modify the program.                                                                                                                                                                                                                                                                                                                                                                                                                                                                                                                                                                                                                                                                                                                                                                                                               |
| 125    | FORMAT ERROR IN MACRO             | <Formula> format is erroneous. Modify the program.                                                                                                                                                                                                                                                                                                                                                                                                                                                                                                                                                                                                                                                                                                                                                                                                                       |
| 126    | ILLEGAL LOOP NUMBER               | In DO n, $1 \leq n \leq 3$ is not established. Modify the program.                                                                                                                                                                                                                                                                                                                                                                                                                                                                                                                                                                                                                                                                                                                                                                                                       |
| 127    | NC, MACRO STATEMENT IN SAME BLOCK | NC and custom macro commands coexist.<br>Modify the program.                                                                                                                                                                                                                                                                                                                                                                                                                                                                                                                                                                                                                                                                                                                                                                                                             |
| 128    | ILLEGAL MACRO SEQUENCE NUMBER     | The sequence number specified in the branch command was not 0 to 9999. Or, it cannot be searched. Modify the program.                                                                                                                                                                                                                                                                                                                                                                                                                                                                                                                                                                                                                                                                                                                                                    |
| 129    | ILLEGAL ARGUMENT ADDRESS          | An address which is not allowed in <Argument Designation > is used.<br>Modify the program.                                                                                                                                                                                                                                                                                                                                                                                                                                                                                                                                                                                                                                                                                                                                                                               |
| 130    | ILLEGAL AXIS OPERATION            | An axis control command was given by PMC to an axis controlled by CNC. Or an axis control command was given by CNC to an axis controlled by PMC. Modify the program.                                                                                                                                                                                                                                                                                                                                                                                                                                                                                                                                                                                                                                                                                                     |
| 131    | TOO MANY EXTERNAL ALARM MESSAGES  | Five or more alarms have generated in external alarm message.<br>Consult the PMC ladder diagram to find the cause.                                                                                                                                                                                                                                                                                                                                                                                                                                                                                                                                                                                                                                                                                                                                                       |
| 132    | ALARM NUMBER NOT FOUND            | No alarm No. concerned exists in external alarm message clear.<br>Check the PMC ladder diagram.                                                                                                                                                                                                                                                                                                                                                                                                                                                                                                                                                                                                                                                                                                                                                                          |
| 133    | ILLEGAL DATA IN EXT. ALARM MSG    | Small section data is erroneous in external alarm message or external operator message. Check the PMC ladder diagram.                                                                                                                                                                                                                                                                                                                                                                                                                                                                                                                                                                                                                                                                                                                                                    |
| 135    | SPINDLE ORIENTATION PLEASE        | Without any spindle orientation, an attempt was made for spindle indexing. Perform spindle orientation.                                                                                                                                                                                                                                                                                                                                                                                                                                                                                                                                                                                                                                                                                                                                                                  |
| 136    | C/H-CODE & MOVE CMD IN SAME BLK.  | A move command of other axes was specified to the same block as spindle indexing addresses C, H. Modify the program.                                                                                                                                                                                                                                                                                                                                                                                                                                                                                                                                                                                                                                                                                                                                                     |

| Number | Message                                                        | Contents                                                                                                                                                                                                                                                                                                          |
|--------|----------------------------------------------------------------|-------------------------------------------------------------------------------------------------------------------------------------------------------------------------------------------------------------------------------------------------------------------------------------------------------------------|
| 137    | M-CODE & MOVE CMD IN SAME BLK.                                 | A move command of other axes was specified to the same block as M-code related to spindle indexing. Modify the program.                                                                                                                                                                                           |
| 138    | G SUPERIMPOSED DATA OVERFLOW                                   | In PMC axis control, the increment for pulse distribution on the CNC and PMC side are too large when the superimposed control extended function is used.                                                                                                                                                          |
| 139    | CAN NOT CHANGE PMC CONTROL AXIS                                | An axis is selected in commanding by PMC axis control. Modify the program.                                                                                                                                                                                                                                        |
| 145    | ILLEGAL COMMAND G112/G113                                      | The conditions are incorrect when the polar coordinate interpolation starts or it is canceled.<br>1) In modes other than G40, G12.1/G13.1 was specified.<br>2) An error is found in the plane selection. Parameters No. 5460 and No. 5461 are incorrectly specified.<br>Modify the value of program or parameter. |
| 146    | IMPROPER G CODE                                                | G codes which cannot be specified in the polar coordinate interpolation mode was specified. See section II-4.4 and modify the program.                                                                                                                                                                            |
| 149    | FORMAT ERROR IN G10L3                                          | A code other than Q1, Q2, P1 or P2 was specified as the life count type in the extended tool life management.                                                                                                                                                                                                     |
| 150    | ILLEGAL TOOL GROUP NUMBER                                      | Tool Group No. exceeds the maximum allowable value. Modify the program.                                                                                                                                                                                                                                           |
| 151    | TOOL GROUP NUMBER NOT FOUND                                    | The tool group commanded in the machining program is not set. Modify the value of program or parameter.                                                                                                                                                                                                           |
| 152    | NO SPACE FOR TOOL ENTRY                                        | The number of tools within one group exceeds the maximum value registrable. Modify the number of tools.                                                                                                                                                                                                           |
| 153    | T-CODE NOT FOUND                                               | In tool life data registration, a T code was not specified where one should be. Correct the program.                                                                                                                                                                                                              |
| 155    | ILLEGAL T-CODE IN M06                                          | In the machining program, M06 and T code in the same block do not correspond to the group in use. Correct the program.                                                                                                                                                                                            |
| 156    | P/L COMMAND NOT FOUND                                          | P and L commands are missing at the head of program in which the tool group is set. Correct the program.                                                                                                                                                                                                          |
| 157    | TOO MANY TOOL GROUPS                                           | The number of tool groups to be set exceeds the maximum allowable value. (See parameter No. 6800 bit 0 and 1) Modify the program.                                                                                                                                                                                 |
| 158    | ILLEGAL TOOL LIFE DATA                                         | The tool life to be set is too excessive. Modify the setting value.                                                                                                                                                                                                                                               |
| 159    | TOOL DATA SETTING INCOMPLETE                                   | During executing a life data setting program, power was turned off. Set again.                                                                                                                                                                                                                                    |
| 160    | MISMATCH WAITING M CODE (At two-path control)                  | Diffrent M code is commanded in heads 1 and 2 as waiting M code. Modify the program.                                                                                                                                                                                                                              |
|        | MISMATCH WAITING M CODE (At three-path control)                | 1) The P commands are identical, but the waiting M codes are different.<br>2) Although the M codes are identical, the P commands do not match.<br>3) A two-path wait and three-path wait are simultaneously specified. Modify the program.                                                                        |
| 161    | ILLEGAL P OF WAITING M-CODE (T series) (At three-path control) | 1) The value of address P is negative, 1, 2, 4, 8, or a greater value.<br>2) The P value does not match the system configuration. Modify the program.                                                                                                                                                             |
| 163    | COMMAND G68/G69 INDEPENDENTLY T series (At two-path control)   | G68 and G69 are not independently commanded in balance cut. Modify the program.                                                                                                                                                                                                                                   |
| 169    | ILLEGAL TOOL GEOMETRY DATA (only with two path control)        | Incorrect tool figure data in interference check.                                                                                                                                                                                                                                                                 |

| Number | Message                          | Contents                                                                                                                                                                                                                                                                                                                                                                 |
|--------|----------------------------------|--------------------------------------------------------------------------------------------------------------------------------------------------------------------------------------------------------------------------------------------------------------------------------------------------------------------------------------------------------------------------|
| 175    | ILLEGAL G107 COMMAND             | Conditions when performing circular interpolation start or cancel not correct. To change the mode to the cylindrical interpolation mode, specify the command in a format of "G07.1 rotation-axis name radius of cylinder."                                                                                                                                               |
| 176    | IMPROPER G-CODE IN G107          | Any of the following G codes which cannot be specified in the cylindrical interpolation mode was specified.<br>1) G codes for positioning, such as G28, G76, G81 – G89, including the codes specifying the rapid traverse cycle<br>2) G codes for setting a coordinate system: G50, G52<br>3) G code for selecting coordinate system: G53 G54–G59<br>Modify the program. |
| 177    | CHECK SUM ERROR (G05 MODE)       | Check sum error<br>Modify the program.                                                                                                                                                                                                                                                                                                                                   |
| 178    | G05 NOT ALLOWED IN G41/G42 MODE  | G05 was commanded in the G41/G42 mode.<br>Correct the program.                                                                                                                                                                                                                                                                                                           |
| 179    | PARAM. (NO. 7510) SETTING ERROR  | The number of controlled axes set by the parameter 7510 exceeds the maximum number. Modify the parameter setting value.                                                                                                                                                                                                                                                  |
| 180    | COMMUNICATION ERROR (REMOTE BUF) | Remote buffer connection alarm has generated. Confirm the number of cables, parameters and I/O device.                                                                                                                                                                                                                                                                   |
| 190    | ILLEGAL AXIS SELECT              | In the constant surface speed control, the axis specification is wrong. (See parameter No. 3770.) The specified axis command (P) contains an illegal value.<br>Correct the program.                                                                                                                                                                                      |
| 194    | SPINDLE COMMAND IN SYNCHRO-MODE  | A contour control mode, spindle positioning (Cs-axis control) mode, or rigid tapping mode was specified during the serial spindle synchronous control mode. Correct the program so that the serial spindle synchronous control mode is released in advance.                                                                                                              |
| 197    | C-AXIS COMMANDED IN SPINDLE MODE | The program specified a movement along the Cf-axis when the signal CON(DGN=G027#7) was off. Correct the program, or consult the PMC ladder diagram to find the reason the signal is not turned on.                                                                                                                                                                       |
| 199    | MACRO WORD UNDEFINED             | Undefined macro word was used. Modify the custom macro.                                                                                                                                                                                                                                                                                                                  |
| 200    | ILLEGAL S CODE COMMAND           | In the rigid tapping, an S value is out of the range or is not specified. The maximum values for S which can be specified in rigid tapping is set in parameters 5241 to 5243. Change the setting in the parameter or modify the program.                                                                                                                                 |
| 201    | FEEDRATE NOT FOUND IN RIGID TAP  | In the rigid tapping, no F value is specified.<br>Correct the program.                                                                                                                                                                                                                                                                                                   |
| 202    | POSITION LSI OVERFLOW            | In the rigid tapping, spindle distribution value is too large.                                                                                                                                                                                                                                                                                                           |
| 203    | PROGRAM MISS AT RIGID TAPPING    | In the rigid tapping, position for a rigid M code (M29) or an S command is incorrect. Modify the program.                                                                                                                                                                                                                                                                |
| 204    | ILLEGAL AXIS OPERATION           | In the rigid tapping, an axis movement is specified between the rigid M code (M29) block and G84 (G88) block. Modify the program.                                                                                                                                                                                                                                        |
| 205    | RIGID MODE DI SIGNAL OFF         | 1 Rigid tapping signal (DGNG061 #1) is not 1 when G84 (G88) is executed though the rigid M code (M29) is specified.<br>2 The spindle of rigid tapping is not selected in a multi-spindle system (by DI signal G27, #0 and #1, or G61, #4 and #5).<br>Consult the PMC ladder diagram to find the reason the signal is not turned on.                                      |
| 207    | RIGID DATA MISMATCH              | The specified distance was too short or too long in rigid tapping.                                                                                                                                                                                                                                                                                                       |
| 210    | CAN NOT COMAND M198/M099         | 1 M198 and M199 are executed in the schedule operation. Or M198 is executed in the DNC operation. Modify the program.<br>2 In a multiple repetitive pocketing canned cycle, an interrupt macro was specified, and M99 was executed.                                                                                                                                      |



| Number | Message                                                              | Contents                                                                                                                                                                                                                                                                                                                                                                                                                                                                                                                                         |
|--------|----------------------------------------------------------------------|--------------------------------------------------------------------------------------------------------------------------------------------------------------------------------------------------------------------------------------------------------------------------------------------------------------------------------------------------------------------------------------------------------------------------------------------------------------------------------------------------------------------------------------------------|
| 211    | G31 (HIGH) NOT ALLOWED IN G99                                        | G31 is commanded in the per revolution command when the high-speed skip option is provided. Modify the program.                                                                                                                                                                                                                                                                                                                                                                                                                                  |
| 212    | ILLEGAL PLANE SELECT                                                 | The direct drawing dimensions programming is commanded for the plane other than the Z-X plane. Correct the program.                                                                                                                                                                                                                                                                                                                                                                                                                              |
| 213    | ILLEGAL COMMAND IN SYNCHRO-MODE                                      | Movement is commanded for the axis to be synchronously controlled.                                                                                                                                                                                                                                                                                                                                                                                                                                                                               |
| 214    | ILLEGAL COMMAND IN SYNCHRO-MODE                                      | Coordinate system is set or tool compensation of the shift type is executed in the synchronous control. Correct the program.                                                                                                                                                                                                                                                                                                                                                                                                                     |
| 217    | DUPLICATE G251 (COMMANDS)                                            | G51.2 or G251 is further commanded in the polygon machining mode. Modify the program.                                                                                                                                                                                                                                                                                                                                                                                                                                                            |
| 218    | NOT FOUND P/Q COMMAND IN G251                                        | P or Q is not commanded in the G251 block, or the command value is out of the range. Modify the program.                                                                                                                                                                                                                                                                                                                                                                                                                                         |
| 219    | COMMAND G250/G251 INDEPENDENTLY                                      | G251 and G250 are not independent blocks.                                                                                                                                                                                                                                                                                                                                                                                                                                                                                                        |
| 220    | ILLEGAL COMMAND IN SYNCHR-MODE                                       | In the synchronous operation, movement is commanded by the NC program or PMC axis control interface for the synchronous axis.                                                                                                                                                                                                                                                                                                                                                                                                                    |
| 221    | ILLEGAL COMMAND IN SYNCHR-MODE                                       | Polygon machining synchronous operation and axis control or balance cutting are executed at a time. Modify the program.                                                                                                                                                                                                                                                                                                                                                                                                                          |
| 224    | RETURN TO REFERENCE POINT                                            | Not returned to reference point before cycle start.                                                                                                                                                                                                                                                                                                                                                                                                                                                                                              |
| 225    | SYNCHRONOUS/MIXED CONTROL ERROR<br>(only with two path control only) | This alarm is generated in the following circumstances. (Searched for during synchronous and mixed control command.<br>1 When there is a mistake in axis number parameter setting.<br>2 When there is a mistake in control commanded.<br>Modify the program or the parameter.                                                                                                                                                                                                                                                                    |
| 226    | ILLEGAL COMMAND IN SYNCHRO-MODE<br>(only with two path control only) | A travel command has been sent to the axis being synchronized in synchronous mode. Modify the program or the parameter.                                                                                                                                                                                                                                                                                                                                                                                                                          |
| 229    | CAN NOT KEEP SYNCHRO-STATE<br>(only with two path control only)      | This alarm is generated in the following circumstances.<br>1 When the synchro/mixed state could not be kept due to system overload.<br>2 The above condition occurred in CNC devices (hardware) and synchro-state could not be kept.<br>(This alarm is not generated in normal use conditions.)                                                                                                                                                                                                                                                  |
| 231    | FORMAT ERROR IN G10 OR L50                                           | Any of the following errors occurred in the specified format at the programmable-parameter input.<br>1 Address N or R was not entered.<br>2 A number not specified for a parameter was entered.<br>3 The axis number was too large.<br>4 An axis number was not specified in the axis-type parameter.<br>5 An axis number was specified in the parameter which is not an axis type.<br>6 An attempt was made to reset bit 4 of parameter 3202 (NE9) or change parameter 3210 (PSSWD) when they are protected by a password. Correct the program. |
| 232    | ILLEGAL AXIS COMMAND IN HELICAL                                      | Three or more axes were specified as helical axes in the helical interpolation mode.                                                                                                                                                                                                                                                                                                                                                                                                                                                             |
| 233    | DEVICE BUSY                                                          | When an attempt was made to use a unit such as that connected via the RS-232-C interface, other users were using it.                                                                                                                                                                                                                                                                                                                                                                                                                             |
| 239    | BP/S ALARM                                                           | While punching was being performed with the function for controlling external I/O units, background editing was performed.                                                                                                                                                                                                                                                                                                                                                                                                                       |

| Number | Message                            | Contents                                                                                                                                                                                                                                                                                              |
|--------|------------------------------------|-------------------------------------------------------------------------------------------------------------------------------------------------------------------------------------------------------------------------------------------------------------------------------------------------------|
| 240    | BP/S ALARM                         | Background editing was performed during MDI operation.                                                                                                                                                                                                                                                |
| 244    | P/S ALARM                          | In the skip function activated by the torque limit signal, the number of accumulated erroneous pulses exceed 32767 before the signal was input. Therefore, the pulses cannot be corrected with one distribution. Change the conditions, such as federates along axes and torque limit, and try again. |
| 245    | T-CODE NOT ALLOWED IN THIS BLOCK   | One of the G codes, G50, G10, and G04, which cannot be specified in the same block as a T code, was specified with a T code.                                                                                                                                                                          |
| 246    | ENCODE PROGRAM NUMBER ERROR        | During read of an encrypted program, an attempt was made to store the program with a number exceeding the protection range. (See parameter Nos. 3222 and 3223.)                                                                                                                                       |
| 247    | ILLEGAL CODE USED FOR OUTPUT       | When an encrypted program is output, EIA is set for the punch code. Specify ISO.                                                                                                                                                                                                                      |
| 5010   | END OF RECORD                      | The end of record (%) was specified.                                                                                                                                                                                                                                                                  |
| 5014   | TRACE DATA NOT FOUND               | Transfer cannot be performed with servo trace function because no trace data exists.                                                                                                                                                                                                                  |
| 5016   | ILLEGAL COMBINATION OF M CODE      | M codes which belonged to the same group were specified in a block. Alternatively, an M code which must be specified without other M codes in the block was specified in a block with other M codes.                                                                                                  |
| 5018   | POLYGON AXIS SPPED ERROR           | The rotating speed ratio of the command value cannot be maintained in the G51.2 mode, because the speed of the spindle or the polygon turning synchronous axis exceeds the clamp value or it is too slow.                                                                                             |
| 5020   | PARAMETER OF RESTART ERROR         | An erroneous parameter was specified for restarting a program.                                                                                                                                                                                                                                        |
| 5030   | ILLEGAL COMMAND (G100)             | The end command (G110) was specified before the registration start command (G101, G102, or G103) was specified for the B-axis.                                                                                                                                                                        |
| 5031   | ILLEGAL COMMAND (G100, G102, G103) | While a registration start command (G101, G102, or G103) was being executed, another registration start command was specified for the B-axis.                                                                                                                                                         |
| 5032   | NEW PRG REGISTERED IN B-AXS MOVE   | While the machine was moving about the B-axis, an attempt was made to register another move command.                                                                                                                                                                                                  |
| 5033   | NO PROG SPACE IN MEMORY B-AXIS     | Commands for movement about the B-axis were not registered because of insufficient program memory.                                                                                                                                                                                                    |
| 5034   | PLURAL COMMAND IN G110             | Multiple movements were specified with the G110 code for the B-axis.                                                                                                                                                                                                                                  |
| 5035   | NO FEEDRATE COMMANDED B-AXIS       | A feedrate was not specified for cutting feed about the B-axis.                                                                                                                                                                                                                                       |
| 5036   | ADDRESS R NOT DEFINED IN G81-G86   | Point R was not specified for the canned cycle for the B-axis.                                                                                                                                                                                                                                        |
| 5037   | ADDRESS Q NOT DEFINED IN G83       | Depth of cut Q was not specified for the G83 code (peck drilling cycle). Alternatively, 0 was specified in Q for the B-axis.                                                                                                                                                                          |
| 5038   | TOO MANY START M-CODE COMMAND      | More than six M codes for starting movement about the B-axis were specified.                                                                                                                                                                                                                          |
| 5039   | START UNREGISTERED B-AXIS PROG     | An attempt was made to execute a program for the B-axis which had not been registered.                                                                                                                                                                                                                |
| 5040   | CAN NOT COMMANDED B-AXIS MOVE      | The machine could not move about the B-axis because parameter No.8250 was incorrectly specified, or because the PMC axis system could not be used.                                                                                                                                                    |
| 5041   | CAN NOT COMMANDED G110 BLOCK       | Blocks containing the G110 codes were successively specified in tool-tip radius compensation for the B-axis.                                                                                                                                                                                          |
| 5043   | TOO MANY G68 NESTING               | Three-dimensional coordinate conversion G68.1 has been specified three or more times.                                                                                                                                                                                                                 |

| Number | Message                          | Contents                                                                                                                                                                                                                                                                                                                                                                                                                                                                                                                                                                                                                                            |
|--------|----------------------------------|-----------------------------------------------------------------------------------------------------------------------------------------------------------------------------------------------------------------------------------------------------------------------------------------------------------------------------------------------------------------------------------------------------------------------------------------------------------------------------------------------------------------------------------------------------------------------------------------------------------------------------------------------------|
| 5044   | G68.1 FORMAT ERROR               | A G68 command block contains a format error. This alarm is issued in the following cases:<br>1 I, J, or K is missing from a G68.1 command block (missing coordinate rotation option).<br>2 I, J, and K are 0 in a G68.1 command block.<br>3 R is missing from a G68.1 command block.<br>Modify the program.                                                                                                                                                                                                                                                                                                                                         |
| 5046   | ILLEGAL PARAMETER (ST.COMP)      | Parameters related to straightness compensation have been erroneously specified. Possible causes are as follows :<br>1 Invalid axis numbers have been assigned to move or compensation axes.<br>2 The number of pitcherror compensation points between the maximum positive and maximum negative points exceeds 128.<br>3 Straightness compensation point numbers have been assigned in other than ascending order.<br>4 Straightness compensation points could not be located between the maximum positive and maximum negative pitch error compensation points.<br>5 The amount of compensation per compensation point is too large or too small. |
| 5051   | M-NET CODE ERROR                 | Abnormal character reception<br>(Characters except code used to transmit)                                                                                                                                                                                                                                                                                                                                                                                                                                                                                                                                                                           |
| 5052   | M-NET ETX ERROR                  | "ETX" code is abnormal.                                                                                                                                                                                                                                                                                                                                                                                                                                                                                                                                                                                                                             |
| 5053   | M-NET CONNECT ERROR              | Connection time supervision error (parameter No.175)                                                                                                                                                                                                                                                                                                                                                                                                                                                                                                                                                                                                |
| 5054   | M-NET RECEIVE ERROR              | Boring time supervision error (parameter No.176)                                                                                                                                                                                                                                                                                                                                                                                                                                                                                                                                                                                                    |
| 5055   | M-NET PRT/FRM ERROR              | Vertical parity or framing error detection                                                                                                                                                                                                                                                                                                                                                                                                                                                                                                                                                                                                          |
| 5056   | M-NET BOARD SYSTEM DOWN          | Transmit time-out error (parameter No. 177)<br>ROM parity error<br>CPU interruption detection of not listed above                                                                                                                                                                                                                                                                                                                                                                                                                                                                                                                                   |
| 5058   | G35/G36 FORMAT ERROR             | A command for changing the major axis was specified during circular threading. Alternatively, the length of the major axis was specified to be 0.                                                                                                                                                                                                                                                                                                                                                                                                                                                                                                   |
| 5059   | RADIUS IS OUT OF RANGE           | During circular interpolation, the center of the arc specified with I, J, and K caused the radius to exceed nine digits.                                                                                                                                                                                                                                                                                                                                                                                                                                                                                                                            |
| 5073   | NO DECIMAL POINT                 | A decimal point is not specified for a command for which a decimal point must be specified.                                                                                                                                                                                                                                                                                                                                                                                                                                                                                                                                                         |
| 5074   | ADDRESS DUPLICATION ERROR        | The same address appears more than once in a block. Alternatively, a block contains two or more G codes belonging to the same group.                                                                                                                                                                                                                                                                                                                                                                                                                                                                                                                |
| 5082   | DATA SERVER ERROR                | Details are displayed on the data server message screen.                                                                                                                                                                                                                                                                                                                                                                                                                                                                                                                                                                                            |
| 5134   | FSSB : OPEN READY TIME OUT       | Initialization did not place FSSB in the open ready state.                                                                                                                                                                                                                                                                                                                                                                                                                                                                                                                                                                                          |
| 5135   | FSSB : ERROR MODE                | FSSB has entered error mode.                                                                                                                                                                                                                                                                                                                                                                                                                                                                                                                                                                                                                        |
| 5136   | FSSB : NUMBER OF AMPS IS SMALL   | In comparison with the number of controlled axes, the number of amplifiers recognized by FSSB is not enough.                                                                                                                                                                                                                                                                                                                                                                                                                                                                                                                                        |
| 5137   | FSSB : CONFIGURATION ERROR       | FSSB detected a configuration error.                                                                                                                                                                                                                                                                                                                                                                                                                                                                                                                                                                                                                |
| 5138   | FSSB : AXIS SETTING NOT COMPLETE | In automatic setting mode, axis setting has not been made yet. Perform axis setting on the FSSB setting screen.                                                                                                                                                                                                                                                                                                                                                                                                                                                                                                                                     |
| 5139   | FSSB : ERROR                     | Servo initialization did not terminate normally.<br>The optical cable may be defective, or there may be an error in connection to the amplifier or another module.<br>Check the optical cable and the connection status.                                                                                                                                                                                                                                                                                                                                                                                                                            |

| Number | Message                           | Contents                                                                                                                                                                                                                                                                                                                                                                                                                                                                                                                                                                                                               |
|--------|-----------------------------------|------------------------------------------------------------------------------------------------------------------------------------------------------------------------------------------------------------------------------------------------------------------------------------------------------------------------------------------------------------------------------------------------------------------------------------------------------------------------------------------------------------------------------------------------------------------------------------------------------------------------|
| 5155   | NOT RESTART PROGRAM BY G05        | During servo leaning control by G05, an attempt was made to perform restart operation after feed hold or interlock. This restart operation cannot be performed. (G05 leaning control terminates at the same time.)                                                                                                                                                                                                                                                                                                                                                                                                     |
| 5195   | DIRECTION CAN NOT BE JUDGED       | When the touch sensor with a single contact signal input is used in the direct input B function for tool offset measurement values, the stored pulse direction is not constant. One of the following conditions exists: <ul style="list-style-type: none"> <li>· The stop state exists in offset write mode.</li> <li>· Servo off state</li> <li>· The direction varies.</li> <li>· Movement takes place simultaneously along two axes.</li> </ul>                                                                                                                                                                     |
| 5197   | FSSB : OPEN TIME OUT              | The CNC permitted FSSB to open, but FSSB was not opened.                                                                                                                                                                                                                                                                                                                                                                                                                                                                                                                                                               |
| 5198   | FSSB : ID DATA NOT READ           | Temporary assignment failed, so amplifier initial ID information could not be read.                                                                                                                                                                                                                                                                                                                                                                                                                                                                                                                                    |
| 5199   | FINE TORQUE SENSING PARAMETER     | A parameter related to the fine torque sensing function is illegal. <ul style="list-style-type: none"> <li>· The storage interval is invalid.</li> <li>· An invalid axis number is set as the target axis.</li> </ul> Correct the parameter.                                                                                                                                                                                                                                                                                                                                                                           |
| 5212   | SCREEN COPY : PARAMETER ERROR     | There is a parameter setting error. Check that 4 is set as the I/O channel (parameter No. 90020).                                                                                                                                                                                                                                                                                                                                                                                                                                                                                                                      |
| 5213   | SCREEN COPY : COMMUNICATION ERROR | The memory card cannot be used. Check the memory card. (Check whether the memory card is write-protected or defective.)                                                                                                                                                                                                                                                                                                                                                                                                                                                                                                |
| 5214   | SCREEN COPY : DATA TRANSFER ERROR | Data transfer to the memory card failed. Check whether the memory card space is insufficient and whether the memory card was removed during data transfer.                                                                                                                                                                                                                                                                                                                                                                                                                                                             |
| 5218   | ILLEGAL PARAMETER (INCL. COMP)    | There is an inclination compensation parameter setting error. Cause: <ol style="list-style-type: none"> <li>1. The number of pitch error compensation points between the negative (-) end and positive (+) end exceeds 128.</li> <li>2. The relationship in magnitude among the inclination compensation point numbers is incorrect.</li> <li>3. An inclination compensation point is not located between the negative (-) end and positive (+) end of the pitch error compensation points.</li> <li>4. The amount of compensation per compensation point is too large or too small.</li> </ol> Correct the parameter. |
| 5220   | REFERENCE POINT ADJUSTMENT MODE   | A parameter for automatically set a reference position is set. (Bit 2 of parameter No. 1819 = 1)<br>Perform automatic setting.<br>(Position the machine at the reference position manually, then perform manual reference position return.)<br>Supplementary: Automatic setting sets bit 2 of parameter No. 1819 to 0.                                                                                                                                                                                                                                                                                                 |
| 5222   | SRAM CORRECTABLE ERROR            | The SRAM correctable error cannot be corrected. Cause:<br>A memory problem occurred during memory initialization. Action:<br>Replace the master printed circuit board (SRAM module).                                                                                                                                                                                                                                                                                                                                                                                                                                   |
| 5227   | FILE NOT FOUND                    | A specified file is not found during communication with the built-in Handy File.                                                                                                                                                                                                                                                                                                                                                                                                                                                                                                                                       |
| 5228   | SAME NAME USED                    | There are duplicate file names in the built-in Handy File.                                                                                                                                                                                                                                                                                                                                                                                                                                                                                                                                                             |
| 5229   | WRITE PROTECTED                   | A floppy disk in the built-in Handy File is write protected.                                                                                                                                                                                                                                                                                                                                                                                                                                                                                                                                                           |

| Number | Message                         | Contents                                                                                                                                                                                                                                                                                                           |
|--------|---------------------------------|--------------------------------------------------------------------------------------------------------------------------------------------------------------------------------------------------------------------------------------------------------------------------------------------------------------------|
| 5231   | TOO MANY FILES                  | The number of files exceeds the limit during communication with the built-in Handy File.                                                                                                                                                                                                                           |
| 5232   | DATA OVER-FLOW                  | There is not enough floppy disk space in the built-in Handy File.                                                                                                                                                                                                                                                  |
| 5235   | COMMUNICATION ERROR             | A communication error occurred during communication with the built-in Handy File.                                                                                                                                                                                                                                  |
| 5237   | READ ERROR                      | A floppy disk in the built-in Handy File cannot be read from. The floppy disk may be defective, or the head may be dirty. Alternatively, the Handy File is defective.                                                                                                                                              |
| 5238   | WRITE ERROR                     | A floppy disk in the built-in Handy File cannot be written to. The floppy disk may be defective, or the head may be dirty. Alternatively, the Handy File is defective.                                                                                                                                             |
| 5242   | ILLEGAL AXIS NUMBER             | The axis number of the synchronous master axis or slave axis is incorrect. (This alarm is issued when flexible synchronization is turned on.) Alternatively, the axis number of the slave axis is smaller than that of the master axis.                                                                            |
| 5243   | DATA OUT OF RANGE               | The gear ratio is not set correctly. (This alarm is issued when flexible synchronization is turned on.)                                                                                                                                                                                                            |
| 5244   | TOO MANY DI ON                  | Even when an M code was encountered in automatic operation mode, the flexible synchronization mode signal was not driven on or off. Check the ladder and M codes.                                                                                                                                                  |
| 5245   | OTHER AXIS ARE COMMANDED        | One of the following command conditions was present during flexible synchronization or when flexible synchronization was turned on:<br>1. The synchronous master axis or slave axis is the EGB axis.<br>2. The synchronous master axis or slave axis is the chopping axis.<br>3. In reference position return mode |
| 5251   | ILLEGAL PARAMETER IN G54.2      | A fixture offset parameter (No. 7580 to 7588) is illegal. Correct the parameter.                                                                                                                                                                                                                                   |
| 5252   | ILLEGAL P COMMAND IN G54.2      | The P value specifying the offset number of a fixture offset is too large. Correct the program.                                                                                                                                                                                                                    |
| 5257   | G41/G42 NOT ALLOWED IN MDI MODE | G41/G42 (cutter compensation C: M series, tool-nose radius compensation: T series) was specified in MDI mode. (Depending on the setting of bit 4 of parameter No. 5008)                                                                                                                                            |
| 5303   | TOUCH PANEL ERROR               | A touch panel error occurred.<br>Cause:<br>1. The touch panel is kept pressed.<br>2. The touch panel was pressed when power was turned on.<br>Remove the above causes, and turn on the power again.                                                                                                                |
| 5306   | MODE CHANGE ERROR               | In an one-touch macro call, the mode is not normally switched at the beginning.                                                                                                                                                                                                                                    |

## 2) Background edit alarm

| Number                   | Message    | Contents                                                                                                                                              |
|--------------------------|------------|-------------------------------------------------------------------------------------------------------------------------------------------------------|
| 070 to 074<br>085 to 087 | BP/S alarm | BP/S alarm occurs in the same number as the P/S alarm that occurs in ordinary program edit.                                                           |
| 140                      | BP/S alarm | It was attempted to select or delete in the background a program being selected in the foreground. <b>(NOTE)</b><br>Use background editing correctly. |

**NOTE**

Alarm in background edit is displayed in the key input line of the background edit screen instead of the ordinary alarm screen and is resettable by any of the MDI key operation.

**3) Absolute pulse coder (APC) alarm**

| Number | Message                         | Contents                                                                                                                                                                                                                             |
|--------|---------------------------------|--------------------------------------------------------------------------------------------------------------------------------------------------------------------------------------------------------------------------------------|
| 300    | n AXIS NEED ZRN                 | Manual reference position return is required for the nth-axis (n=1 to 8).                                                                                                                                                            |
| 301    | APC ALARM:n AXIS COMMUNICATION  | nth-axis (n=1 to 8) APC communication error. Failure in data transmission<br>Possible causes include a faulty APC, cable, or servo interface module.                                                                                 |
| 302    | APC ALARM:n AXIS OVER TIME      | nth-axis (n=1 to 8) APC overtime error.<br>Failure in data transmission.<br>Possible causes include a faulty APC, cable, or servo interface module.                                                                                  |
| 303    | APC ALARM:n AXIS FRAMING        | nth-axis (n=1 to 8) APC framing error. Failure in data transmission.<br>Possible causes include a faulty APC, cable, or servo interface module.                                                                                      |
| 304    | APC ALARM:n AXIS PARITY         | nth-axis (n=1 to 8) APC parity error.<br>Failure in data transmission. Possible causes include a faulty APC, cable, or servo interface module.                                                                                       |
| 305    | APC ALARM:n AXIS PULSE MISS     | nth-axis (n=1 to 8) APC pulse error alarm.<br>APC alarm. APC or cable may be faulty.                                                                                                                                                 |
| 306    | APC ALARM:n AXIS BATTERY ZERO   | nth-axis (n=1 to 8) APC battery voltage has decreased to a low level so that the data cannot be held.<br>APC alarm. Battery or cable may be faulty.                                                                                  |
| 307    | APC ALARM:n AXIS BATTERY DOWN 1 | nth-axis (n=1 to 8) axis APC battery voltage reaches a level where the battery must be renewed.<br>APC alarm. Replace the battery.                                                                                                   |
| 308    | APC ALARM:n AXIS BATTERY DOWN 2 | nth-axis (n=1 to 8) APC battery voltage has reached a level where the battery must be renewed (including when power is OFF).<br>APC alarm .Replace battery.                                                                          |
| 309    | APC ALARM:n AXIS ZRN IMPOSSIBLE | An attempt was made to perform reference position return without rotating the motor through one or more turns. Rotate the motor through one or more turns, turn off the power then on again, then perform reference position return. |

**4) Serial pulse coder (SPC) alarms**

| No. | Message                            | Description                                                                                              |
|-----|------------------------------------|----------------------------------------------------------------------------------------------------------|
| 360 | n AXIS : ABNORMAL CHECKSUM (INT)   | A checksum error occurred in the built-in pulse coder.                                                   |
| 361 | n AXIS : ABNORMAL PHASE DATA (INT) | A phase data error occurred in the built-in pulse coder.                                                 |
| 362 | n AXIS : ABNORMAL REV.DATA (INT)   | A rotation speed count error occurred in the built-in pulse coder.                                       |
| 363 | n AXIS : ABNORMAL CLOCK (INT)      | A clock error occurred in the built-in pulse coder.                                                      |
| 364 | n AXIS : SOFT PHASE ALARM (INT)    | The digital servo software detected invalid data in the built-in pulse coder.                            |
| 365 | n AXIS : BROKEN LED (INT)          | An LED error occurred in the built-in pulse coder.                                                       |
| 366 | n AXIS : PULSE MISS (INT)          | A pulse error occurred in the built-in pulse coder.                                                      |
| 367 | n AXIS : COUNT MISS (INT)          | A count error occurred in the built-in pulse coder.                                                      |
| 368 | n AXIS : SERIAL DATA ERROR (INT)   | Communication data from the built-in pulse coder cannot be received.                                     |
| 369 | n AXIS : DATA TRANS. ERROR (INT)   | A CRC or stop bit error occurred in the communication data being received from the built-in pulse coder. |

| No. | Message                           | Description                                                                                           |
|-----|-----------------------------------|-------------------------------------------------------------------------------------------------------|
| 380 | n AXIS : BROKEN LED (EXT)         | The separate detector is erroneous.                                                                   |
| 381 | n AXIS : ABNORMAL PHASE (EXT LIN) | A phase data error occurred in the separate linear scale.                                             |
| 382 | n AXIS : COUNT MISS (EXT)         | A pulse error occurred in the separate detector.                                                      |
| 383 | n AXIS : PULSE MISS (EXT)         | A count error occurred in the separate detector.                                                      |
| 384 | n AXIS : SOFT PHASE ALARM (EXT)   | The digital servo software detected invalid data in the separate detector.                            |
| 385 | n AXIS : SERIAL DATA ERROR (EXT)  | Communication data from the separate detector cannot be received.                                     |
| 386 | n AXIS : DATA TRANS. ERROR (EXT)  | A CRC or stop bit error occurred in the communication data being received from the separate detector. |

● The details of serial pulse coder alarm

|     | #7 | #6  | #5  | #4  | #3  | #2  | #1  | #0  |
|-----|----|-----|-----|-----|-----|-----|-----|-----|
| 202 |    | CSA | BLA | PHA | PCA | BZA | CKA | SPH |

#6 (CSA) : Check sum alarm has occurred.

#5 (BLA) : Battery low alarm has occurred.

#4 (PHA) : Phase data trouble alarm has occurred.

#3 (PCA) : Speed count trouble alarm has occurred.

#2 (BZA) : Battery zero alarm has occurred.

#1 (CKA) : Clock alarm has occurred.

#0 (SPH) : Soft phase data trouble alarm has occurred.

|     | #7  | #6  | #5  | #4  | #3 | #2 | #1 | #0 |
|-----|-----|-----|-----|-----|----|----|----|----|
| 203 | DTE | CRC | STB | PRM |    |    |    |    |

#7 (DTE) : Data error has occurred.

#6 (CRC) : CRC error has occurred.

#5 (STB) : Stop bit error has occurred.

#4 (PRM) : Parameter error alarm has occurred. In this case, a servo parameter error alarm (No. 417) is also output.

## 5) Servo alarms

| Number | Message                                | Contents                                                                                                                                                                                                                                                                            |
|--------|----------------------------------------|-------------------------------------------------------------------------------------------------------------------------------------------------------------------------------------------------------------------------------------------------------------------------------------|
| 401    | SERVO ALARM: n-TH AXIS VRDY OFF        | The n-th axis (axis 1-8) servo amplifier READY signal (DRDY) went off. Refer to procedure of trouble shooting.                                                                                                                                                                      |
| 402    | SERVO ALARM: SV CARD NOT EXIST         | The axis control card is not provided.                                                                                                                                                                                                                                              |
| 403    | SERVO ALARM: CARD/SOFT MISMATCH        | The combination of the axis control card and servo software is illegal. The possible causes are as follows:<br><ul style="list-style-type: none"> <li>· A correct axis control card is not provided.</li> <li>· Correct servo software is not installed on flash memory.</li> </ul> |
| 404    | SERVO ALARM: n-TH AXIS VRDY ON         | Even though the n-th axis (axis 1-8) READY signal (MCON) went off, the servo amplifier READY signal (DRDY) is still on. Or, when the power was turned on, DRDY went on even though MCON was off. Check that the servo interface module and servo amp are connected.                 |
| 405    | SERVO ALARM: (ZERO POINT RETURN FAULT) | Position control system fault. Due to an NC or servo system fault in the reference position return, there is the possibility that reference position return could not be executed correctly. Try again from the manual reference position return.                                   |
| 407    | SERVO ALARM: EXCESS ERROR              | The difference in synchronous axis position deviation exceeded the set value.                                                                                                                                                                                                       |
| 409    | SERVO ALARM: n AXIS TORQUE ALM         | Abnormal servo motor load has been detected. Alternatively, abnormal spindle motor load has been detected in Cs mode.                                                                                                                                                               |
| 410    | SERVO ALARM: n-TH AXIS - EXCESS ERROR  | The position deviation value when the n-th axis (axis 1-8) stops is larger than the set value. Refer to procedure of trouble shooting.                                                                                                                                              |
| 411    | SERVO ALARM: n-TH AXIS - EXCESS ERROR  | The position deviation value when the n-th axis (axis 1-8) moves is larger than the set value. Refer to procedure of trouble shooting.                                                                                                                                              |
| 413    | SERVO ALARM: n-th AXIS - LSI OVERFLOW  | The contents of the error register for the n-th axis (axis 1-8) exceeded $\pm 2^{31}$ power. This error usually occurs as the result of an improperly set parameters.                                                                                                               |



| Number | Message                                      | Contents                                                                                                                                                                                                                                                                                                                                                                                                                                                                                                                                                                                                                                                                                                                                                                                                                                                                                                                                                                             |
|--------|----------------------------------------------|--------------------------------------------------------------------------------------------------------------------------------------------------------------------------------------------------------------------------------------------------------------------------------------------------------------------------------------------------------------------------------------------------------------------------------------------------------------------------------------------------------------------------------------------------------------------------------------------------------------------------------------------------------------------------------------------------------------------------------------------------------------------------------------------------------------------------------------------------------------------------------------------------------------------------------------------------------------------------------------|
| 415    | SERVO ALARM: n-TH AXIS – EXCESS SHIFT        | A speed higher than 524288000 units/s was attempted to be set in the n-th axis (axis 1–8). This error occurs as the result of improperly set CMR.                                                                                                                                                                                                                                                                                                                                                                                                                                                                                                                                                                                                                                                                                                                                                                                                                                    |
| 417    | SERVO ALARM: n-TH AXIS – PARAMETER INCORRECT | This alarm occurs when the n-th axis (axis 1–8) is in one of the conditions listed below. (Digital servo system alarm)<br>1) The value set in Parameter No. 2020 (motor form) is out of the specified limit.<br>2) A proper value (111 or –111) is not set in parameter No.2022 (motor revolution direction).<br>3) Illegal data (a value below 0, etc.) was set in parameter No. 2023 (number of speed feedback pulses per motor revolution).<br>4) Illegal data (a value below 0, etc.) was set in parameter No. 2024 (number of position feedback pulses per motor revolution).<br>5) Parameters No. 2084 and No. 2085 (flexible field gear rate) have not been set.<br>6) A value outside the limit of {1 to the number of control axes} or a non-continuous value (Parameter 1023 (servo axis number) contains a value out of the range from 1 to the number of axes, or an isolated value (for example, 4 not preceded by 3).was set in parameter No. 1023 (servo axisnumber). |
| 420    | SERVO ALARM: n AXIS SYNC TORQUE (M series)   | During simple synchronous control, the difference between the torque commands for the master and slave axes exceeded the value set in parameter No. 2031.                                                                                                                                                                                                                                                                                                                                                                                                                                                                                                                                                                                                                                                                                                                                                                                                                            |
| 421    | SERVO ALARM: n AXIS EXCESS ER (D)            | The difference between the errors in the semi-closed loop and closed loop has become excessive during dual position feedback. Check the values of the dual position conversion coefficients in parameters No. 2078 and 2079.                                                                                                                                                                                                                                                                                                                                                                                                                                                                                                                                                                                                                                                                                                                                                         |
| 422    | SERVO ALARM: n AXIS                          | In torque control of PMC axis control, a specified allowable speed has been exceeded.                                                                                                                                                                                                                                                                                                                                                                                                                                                                                                                                                                                                                                                                                                                                                                                                                                                                                                |
| 423    | SERVO ALARM: n AXIS                          | In torque control of PMC axis control, the parameter-set allowable cumulative travel distance has been exceeded.                                                                                                                                                                                                                                                                                                                                                                                                                                                                                                                                                                                                                                                                                                                                                                                                                                                                     |
| 430    | n AXIS : SV. MOTOR OVERHEAT                  | A servo motor overheat occurred.                                                                                                                                                                                                                                                                                                                                                                                                                                                                                                                                                                                                                                                                                                                                                                                                                                                                                                                                                     |
| 431    | n AXIS : CNV. OVERLOAD                       | 1) PSM: Overheat occurred.<br>2) $\beta$ series SVU: Overheat occurred.                                                                                                                                                                                                                                                                                                                                                                                                                                                                                                                                                                                                                                                                                                                                                                                                                                                                                                              |
| 432    | n AXIS : CNV. LOWVOLT CON./POWFAULT          | 1) PSM: Phase missing occurred in the input voltage.<br>2) PSMR: The control power supply voltage has dropped.<br>3) $\alpha$ series SVU: The control power supply voltage has dropped.                                                                                                                                                                                                                                                                                                                                                                                                                                                                                                                                                                                                                                                                                                                                                                                              |
| 433    | n AXIS : CNV. LOW VOLT DC LINK               | 1) PSM: The DC link voltage has dropped.<br>2) PSMR: The DC link voltage has dropped.<br>3) $\alpha$ series SVU: The DC link voltage has dropped.<br>4) $\beta$ series SVU: The DC link voltage has dropped.                                                                                                                                                                                                                                                                                                                                                                                                                                                                                                                                                                                                                                                                                                                                                                         |
| 434    | n AXIS : INV. LOW VOLT CONTROL               | SVM: The control power supply voltage has dropped.                                                                                                                                                                                                                                                                                                                                                                                                                                                                                                                                                                                                                                                                                                                                                                                                                                                                                                                                   |
| 435    | n AXIS : INV. LOW VOLT DC LINK               | SVM: The DC link voltage has dropped.                                                                                                                                                                                                                                                                                                                                                                                                                                                                                                                                                                                                                                                                                                                                                                                                                                                                                                                                                |
| 436    | n AXIS : SOFTTHERMAL (OVC)                   | The digital servo software detected the soft thermal state (OVC).                                                                                                                                                                                                                                                                                                                                                                                                                                                                                                                                                                                                                                                                                                                                                                                                                                                                                                                    |
| 437    | n AXIS : CNV. OVERCURRENT POWER              | PSM: Overcurrent flowed into the input circuit.                                                                                                                                                                                                                                                                                                                                                                                                                                                                                                                                                                                                                                                                                                                                                                                                                                                                                                                                      |
| 438    | n AXIS : INV. ABNORMAL CURRENT               | 1) SVM: The motor current is too high.<br>2) $\alpha$ series SVU: The motor current is too high.<br>3) $\beta$ series SVU: The motor current is too high.                                                                                                                                                                                                                                                                                                                                                                                                                                                                                                                                                                                                                                                                                                                                                                                                                            |

| Number | Message                            | Contents                                                                                                                                                                                                                                                                                                                                                                                                                                 |
|--------|------------------------------------|------------------------------------------------------------------------------------------------------------------------------------------------------------------------------------------------------------------------------------------------------------------------------------------------------------------------------------------------------------------------------------------------------------------------------------------|
| 439    | n AXIS : CNV. OVERVOLT POWER       | <ol style="list-style-type: none"> <li>1) PSM: The DC link voltage is too high.</li> <li>2) PSMR: The DC link voltage is too high.</li> <li>3) <math>\alpha</math> series SVU: The C link voltage is too high.</li> <li>4) <math>\beta</math> series SVU: The link voltage is too high.</li> </ol>                                                                                                                                       |
| 440    | n AXIS : CNV. EX DECELERATION POW. | <ol style="list-style-type: none"> <li>1) PSMR: The regenerative discharge amount is too large.</li> <li>2) <math>\alpha</math> series SVU: The regenerative discharge amount is too large. Alternatively, the regenerative discharge circuit is abnormal.</li> </ol>                                                                                                                                                                    |
| 441    | n AXIS : ABNORMAL CURRENT OFFSET   | The digital servo software detected an abnormality in the motor current detection circuit.                                                                                                                                                                                                                                                                                                                                               |
| 442    | n AXIS : CNV. CHARGE FAULT/INV. DB | <ol style="list-style-type: none"> <li>1) PSM: The spare discharge circuit of the DC link is abnormal.</li> <li>2) PSMR: The spare discharge circuit of the DC link is abnormal.</li> <li>3) <math>\alpha</math> series SVU: The dynamic brake circuit is abnormal.</li> </ol>                                                                                                                                                           |
| 443    | n AXIS : CNV. COOLING FAN FAILURE  | <ol style="list-style-type: none"> <li>1) PSM: The internal stirring fan failed.</li> <li>2) PSMR: The internal stirring fan failed.</li> <li>3) <math>\beta</math> series SVU: The internal stirring fan failed.</li> </ol>                                                                                                                                                                                                             |
| 444    | n AXIS : INV. COOLING FAN FAILURE  | SVM: The internal stirring fan failed.                                                                                                                                                                                                                                                                                                                                                                                                   |
| 445    | n AXIS : SOFT DISCONNECT ALARM     | The digital servo software detected a broken wire in the pulse coder.                                                                                                                                                                                                                                                                                                                                                                    |
| 446    | n AXIS : HARD DISCONNECT ALARM     | A broken wire in the built-in pulse coder was detected by hardware.                                                                                                                                                                                                                                                                                                                                                                      |
| 447    | n AXIS : HARD DISCONNECT (EXT)     | A broken wire in the separate detector was detected by hardware.                                                                                                                                                                                                                                                                                                                                                                         |
| 448    | n AXIS : UNMATCHED FEEDBACK ALARM  | The sign of feedback data from the built-in pulse coder differs from that of feedback data from the separate detector.                                                                                                                                                                                                                                                                                                                   |
| 449    | n AXIS : INV. IPM ALARM            | <ol style="list-style-type: none"> <li>1) SVM: IPM (intelligent power module) detected an alarm.</li> <li>2) <math>\alpha</math> series SVU: IPM (intelligent power module) detected an alarm.</li> </ol>                                                                                                                                                                                                                                |
| 460    | n AXIS : FSSB DISCONNECT           | <p>FSSB communication was disconnected suddenly. The possible causes are as follows:</p> <ol style="list-style-type: none"> <li>1) The FSSB communication cable was disconnected or broken.</li> <li>2) The power to the amplifier was turned off suddenly.</li> <li>3) A low-voltage alarm was issued by the amplifier.</li> </ol>                                                                                                      |
| 461    | n AXIS : ILLEGAL AMP INTERFACE     | The axes of the 2-axis amplifier were assigned to the fast type interface.                                                                                                                                                                                                                                                                                                                                                               |
| 462    | n AXIS : SEND CNC DATA FAILED      | Because of an FSSB communication error, a slave could not receive correct data.                                                                                                                                                                                                                                                                                                                                                          |
| 463    | n AXIS : SEND SLAVE DATA FAILED    | Because of an FSSB communication error, the servo system could not receive correct data.                                                                                                                                                                                                                                                                                                                                                 |
| 464    | n AXIS : WRITE ID DATA FAILED      | An attempt was made to write maintenance information on the amplifier maintenance screen, but it failed.                                                                                                                                                                                                                                                                                                                                 |
| 465    | n AXIS : READ ID DATA FAILED       | At power-up, amplifier initial ID information could not be read.                                                                                                                                                                                                                                                                                                                                                                         |
| 466    | n AXIS : MOTOR/AMP COMBINATION     | The maximum current rating for the amplifier does not match that for the motor.                                                                                                                                                                                                                                                                                                                                                          |
| 467    | n AXIS : ILLEGAL SETTING OF AXIS   | <p>The servo function for the following has not been enabled when an axis occupying a single DSP (corresponding to two ordinary axes) is specified on the axis setting screen.</p> <ol style="list-style-type: none"> <li>1. Learning control (bit 5 of parameter No. 2008 = 1)</li> <li>2. High-speed current loop (bit 0 of parameter No. 2004 = 1)</li> <li>3. High-speed interface axis (bit 4 of parameter No. 2005 = 1)</li> </ol> |

● **Details of servo alarm**

The details of servo alarm are displayed in the diagnosis display (No. 200 and No.204) as shown below.

|     | #7  | #6 | #5  | #4  | #3  | #2  | #1  | #0  |
|-----|-----|----|-----|-----|-----|-----|-----|-----|
| 200 | OVL | LV | OVC | HCA | HVA | DCA | FBA | OFA |

**#7 (OVL)** : An overload alarm is being generated.

**#6 (LV)** : A low voltage alarm is being generated in servo amp.

**#5 (OVC)** : A overcurrent alarm is being generated inside of digital servo.

**#4 (HCA)** : An abnormal current alarm is being generated in servo amp.

**#3 (HVA)** : An overvoltage alarm is being generated in servo amp.

**#2 (DCA)** : A regenerative discharge circuit alarm is being generated in servo amp.

**#1 (FBA)** : A disconnection alarm is being generated.

**#0 (OFA)** : An overflow alarm is being generated inside of digital servo.

|     | #7  | #6 | #5 | #4  | #3 | #2 | #1 | #0 |
|-----|-----|----|----|-----|----|----|----|----|
| 201 | ALD |    |    | EXP |    |    |    |    |

When OVL equal 1 in diagnostic data No.200 (servo alarm No. 400 is being generated):

**#7 (ALD)** 0 : Motor overheating

1 : Amplifier overheating

When FBAL equal 1 in diagnostic data No.200 (servo alarm No. 416 is being generated):

| ALD | EXP | Alarm details                                             |
|-----|-----|-----------------------------------------------------------|
| 1   | 0   | Built-in pulse coder disconnection (hardware)             |
| 1   | 1   | Separately installed pulse coder disconnection (hardware) |
| 0   | 0   | Pulse coder is not connected due to software.             |

|     | #7 | #6  | #5  | #4  | #3  | #2 | #1 | #0 |
|-----|----|-----|-----|-----|-----|----|----|----|
| 204 |    | OFS | MCC | LDA | PMS |    |    |    |

**#6 (OFS)** : A current conversion error has occurred in the digital servo.

**#5 (MCC)** : A magnetic contactor contact in the servo amplifier has welded.

**#4 (LDA)** : The LED indicates that serial pulse coder C is defective.

**#3 (PMS)** : A feedback pulse error has occurred because the feedback cable is defective.

**6) Over travel alarms**

| Number | Message           | Contents                                                                                                                                                                                                 |
|--------|-------------------|----------------------------------------------------------------------------------------------------------------------------------------------------------------------------------------------------------|
| 500    | OVER TRAVEL : +n  | Exceeded the n-th axis (axis 1 to 8) + side stored stroke limit I. (Parameter No.1320 or 1326 <b>NOTE</b> )                                                                                              |
| 501    | OVER TRAVEL : -n  | Exceeded the n-th axis (axis 1 to 8) - side stored stroke limit I. (Parameter No.1321 or 1327 <b>NOTE</b> )                                                                                              |
| 502    | OVER TRAVEL : +n  | Exceeded the n-th axis (axis 1 to 8) + side stored stroke limit II. (Parameter No.1322 )                                                                                                                 |
| 503    | OVER TRAVEL : -n  | Exceeded the n-th axis (axis 1 to 8) - side stored stroke limit II. (Parameter No.1323)                                                                                                                  |
| 504    | OVER TRAVEL : +n  | Exceeded the n-th axis (axis 1 to 8) + side stored stroke limit III. (Parameter No.1324 )                                                                                                                |
| 505    | OVER TRAVEL : -n  | Exceeded the n-th axis (axis 1 to 8) - side stored stroke limit III. (Parameter No.1325 )                                                                                                                |
| 506    | OVER TRAVEL : +n  | Exceeded the n-th axis (axis 1 to 8) + side hardware OT.                                                                                                                                                 |
| 507    | OVER TRAVEL : -n  | Exceeded the n-th axis (axis 1 to 8) - side hardware OT.                                                                                                                                                 |
| 508    | INTERFERENCE : +n | When n-axis is moving in the positive direction, it interferes with the order tool post (only with two-path control)                                                                                     |
| 509    | INTERFERENCE : -n | When n-axis is moving in the negative direction, it interferes with the order tool post (only with two-path control)                                                                                     |
| 510    | OVER TRAVEL : +n  | A stroke limit check, made before starting movement, found that the end point of a block falls within the plus (+) side inhibited area along the n-axis defined by a stroke limit. Correct the program.  |
| 511    | OVER TRAVEL : -n  | A stroke limit check, made before starting movement, found that the end point of a block falls within the minus (-) side inhibited area along the N-axis defined by a stroke limit. Correct the program. |

**NOTE**

Over travel alarms No. 504 and No. 505 are provided only with the T series.  
Parameters 1326 and 1327 are effective when EXLM(stroke limit switch signal) is on.

**7) Overheat alarms**

| Number | Message                | Contents                                                                                                                                                                                                                      |
|--------|------------------------|-------------------------------------------------------------------------------------------------------------------------------------------------------------------------------------------------------------------------------|
| 700    | OVERHEAT: CONTROL UNIT | Control unit overheat<br>Check that the fan motor operates normally, and clean the air filter.                                                                                                                                |
| 701    | OVERHEAT: FAN MOTOR    | The fan motor on the top of the cabinet for the control unit is over-heated. Check the operation of the fan motor and replace the motor if necessary.                                                                         |
| 704    | OVERHEAT: SPINDLE      | Spindle overheat in the spindle fluctuation detection<br>(1)If the cutting load is heavy, relieve the cutting condition.<br>(2)Check whether the cutting tool is share.<br>(3)Another possible cause is a faulty spindle amp. |

**8) Rigid tapping alarm**

| Number | Message                         | Contents                                                                                            |
|--------|---------------------------------|-----------------------------------------------------------------------------------------------------|
| 740    | RIGID TAP ALARM : EXCESS ERROR  | During rigid tapping, the position deviation of the spindle in the stop state exceeded the setting. |
| 741    | RIGID TAP ALARM : EXCESS ERROR  | During rigid tapping, the position deviation of the spindle in the stop state exceeded the setting. |
| 742    | RIGID TAP ALARM : LSI OVER FLOW | During rigid tapping, an LSI overflow occurred on the spindle side.                                 |

### 9) Serial spindle alarms

| Number | Message                          | Contents                                                                                                                                                                                                                                                                                                                                                                                                                                                                                                                                                                                                                                                                                                                                                                                                                                                                   |
|--------|----------------------------------|----------------------------------------------------------------------------------------------------------------------------------------------------------------------------------------------------------------------------------------------------------------------------------------------------------------------------------------------------------------------------------------------------------------------------------------------------------------------------------------------------------------------------------------------------------------------------------------------------------------------------------------------------------------------------------------------------------------------------------------------------------------------------------------------------------------------------------------------------------------------------|
| 749    | S-SPINDLE LSI ERROR              | It is serial communication error while system is executing after power supply on. Following reasons can be considered.<br>1) Optical cable connection is fault or cable is not connected or cable is cut.<br>2) MAIN CPU board or option 2 board is fault.<br>3) Spindle amp. printed board is fault.<br>If this alarm occurs when CNC power supply is turned on or when this alarm can not be cleared even if CNC is reset, turn off the power supply also turn off the power supply in spindle side.                                                                                                                                                                                                                                                                                                                                                                     |
| 750    | SPINDLE SERIAL LINK START FAULT  | This alarm is generated when the spindle control unit is not ready for starting correctly when the power is turned on in the system with the serial spindle.<br>The four reasons can be considered as follows:<br>1) An improperly connected optic cable, or the spindle control unit's power is OFF.<br>2) When the NC power was turned on under alarm conditions other than SU-01 or AL-24 which are shown on the LED display of the spindle control unit.<br>In this case, turn the spindle amplifier power off once and perform startup again.<br>3) Other reasons (improper combination of hardware)<br>This alarm does not occur after the system including the spindle control unit is activated.<br>4) The second spindle (when SP2, bit 4 of parameter No. 3701, is 1) is in one of the above conditions 1) to 3).<br>See diagnostic display No. 409 for details. |
| 752    | FIRST SPINDLE MODE CHANGE FAULT  | This alarm is generated if the system does not properly terminate a mode change. The modes include the Cs contouring, spindle positioning, rigid tapping, and spindle control modes. The alarm is activated if the spindle control unit does not respond correctly to the mode change command issued by the NC.                                                                                                                                                                                                                                                                                                                                                                                                                                                                                                                                                            |
| 754    | SPINDLE-1 ABNORMAL TORQUE ALM    | Abnormal first spindle motor load has been detected.                                                                                                                                                                                                                                                                                                                                                                                                                                                                                                                                                                                                                                                                                                                                                                                                                       |
| 762    | SECOND SPINDLE MODE CHANGE FAULT | Refer to alarm No. 752. (For 2nd axis)                                                                                                                                                                                                                                                                                                                                                                                                                                                                                                                                                                                                                                                                                                                                                                                                                                     |
| 764    | SPINDLE-2 ABNORMAL TORQUE ALM    | Same as alarm No. 754 (for the second spindle)                                                                                                                                                                                                                                                                                                                                                                                                                                                                                                                                                                                                                                                                                                                                                                                                                             |
| 772    | SPINDLE-3 MODE CHANGE ERROR      | Same as alarm No. 752 (for the third spindle)                                                                                                                                                                                                                                                                                                                                                                                                                                                                                                                                                                                                                                                                                                                                                                                                                              |
| 774    | SPINDLE-3 ABNORMAL TORQUE ALM    | Same as alarm No. 754 (for the third spindle)                                                                                                                                                                                                                                                                                                                                                                                                                                                                                                                                                                                                                                                                                                                                                                                                                              |
| 782    | SPINDLE-4 MODE CHANGE ERROR      | Same as alarm number 752 (for the fourth spindle)                                                                                                                                                                                                                                                                                                                                                                                                                                                                                                                                                                                                                                                                                                                                                                                                                          |
| 784    | SPINDLE-4 ABNORMAL TORQUE ALM    | Same as alarm number 754 (for the fourth spindle)                                                                                                                                                                                                                                                                                                                                                                                                                                                                                                                                                                                                                                                                                                                                                                                                                          |

● **The details of spindle alarm No.750**

The details of spindle alarm No. 750 are displayed in the diagnosis display (No. 409) as shown below.

|     | #7 | #6 | #5 | #4 | #3  | #2  | #1  | #0  |
|-----|----|----|----|----|-----|-----|-----|-----|
| 409 |    |    |    |    | SPE | S2E | S1E | SHE |

**#3 (SPE) 0** : In the spindle serial control, the serial spindle parameters fulfill the spindle unit startup conditions.

- 1 : In the spindle serial control, the serial spindle parameters do not fulfill the spindle unit startup conditions.
- #2 (S2E)** 0 : The second spindle is normal during the spindle serial control startup.  
1 : The second spindle was detected to have a fault during the spindle serial control startup.
- #1 (S1E)** 0 : The first spindle is normal during the spindle serial control startup.  
1 : The first spindle was detected to have a fault during the spindle axis serial control startup.
- #0 (SHE)** 0 : The serial communications module in the CNC is normal.  
1 : The serial communications module in the CNC was detected to have a fault.

## Alarm List (Serial Spindle)

When a serial spindle alarm occurs, the following number is displayed on the CNC. n is a number corresponding to the spindle on which an alarm occurs. (n = 1: First spindle; n = 2: Second spindle; etc.)

### NOTE\*1

Note that the meanings of the SPM indications differ depending on which LED, the red or yellow LED, is on. When the red LED is on, the SPM indicates a 2-digit alarm number. When the yellow LED is on, the SPM indicates an error number that designates a sequence problem (for example, when a rotation command is entered with the emergency stop state not released).

→ See Appendix A.4, "Error Codes (Serial Spindle)."

## Alarm Numbers and Alarms Displayed on the $\alpha$ Series Spindle Amplifier

| No.   | Message                            | SPM indication(*1) | Faulty location and remedy                                                                                      | Description                                                                                                                                                                                                                                                |
|-------|------------------------------------|--------------------|-----------------------------------------------------------------------------------------------------------------|------------------------------------------------------------------------------------------------------------------------------------------------------------------------------------------------------------------------------------------------------------|
| (750) | SPINDLE SERIAL LINK ERROR          | A0<br>A            | 1 Replace the ROM on the SPM control printed circuit board.<br>2 Replace the SPM control printed circuit board. | The program does not start normally. ROM series error or hardware abnormality on the SPM control printed circuit board                                                                                                                                     |
| (749) | S-SPINDLE LSI ERROR                | A1                 | Replace the SPM control printed circuit board.                                                                  | An abnormality was detected in the CPU peripheral circuit of the SPM control circuit.                                                                                                                                                                      |
| 7n01  | SPN_n_ : MOTOR OVER-HEAT           | 01                 | 1 Check and correct the peripheral temperature and load status.<br>2 If the cooling fan stops, replace it.      | The thermostat embedded in the motor winding operated.<br>The internal temperature of the motor exceeds the specified level.<br>The motor is used in excess of the continuous rating, or the cooling component is abnormal.                                |
| 7n02  | SPN_n_ : EX SPEED ERROR            | 02                 | 1 Check and correct the cutting conditions to decrease the load.<br>2 Correct parameter No. 4082.               | The motor speed cannot follow a specified speed.<br>An excessive motor load torque is detected.<br>The acceleration/deceleration time in parameter No. 4082 is insufficient.                                                                               |
| 7n03  | SPN_n_ : FUSE ON DC LINK BLOWN     | 03                 | 1 Replace the SPM unit.<br>2 Check the motor insulation status.<br>3 Replace the interface cable.               | The PSM becomes ready (00 is indicated), but the DC link voltage is too low in the SPM.<br>The fuse in the DC link section in the SPM is blown. (The power device is damaged or the motor is ground-fault.)<br>The JX1A/JX1B connection cable is abnormal. |
| 7n06  | SPN_n_ : THERMAL SENSOR DISCONNECT | 06                 | 1 Check and correct the parameter.<br>2 Replace the feedback cable.                                             | The temperature sensor of the motor is disconnected.                                                                                                                                                                                                       |

| No.  | Message                            | SPM indication(*1) | Faulty location and remedy                                                                                                                                                                                                               | Description                                                                                                                                                                                                                |
|------|------------------------------------|--------------------|------------------------------------------------------------------------------------------------------------------------------------------------------------------------------------------------------------------------------------------|----------------------------------------------------------------------------------------------------------------------------------------------------------------------------------------------------------------------------|
| 7n07 | SPN_n_ : OVERSPEED                 | 07                 | Check for a sequence error. (For example, check whether spindle synchronization was specified when the spindle could not be turned.)                                                                                                     | The motor speed has exceeded 115% of its rated speed. When the spindle axis was in position control mode, positional deviations were accumulated excessively (SFR and SRV were turned off during spindle synchronization.) |
| 7n09 | SPN_n_ : OVERHEAT MAIN CIRCUIT     | 09                 | 1 Improve the heat sink cooling status.<br>2 If the heat sink cooling fan stops, replace the SPM unit.                                                                                                                                   | Abnormal temperature rise of the power transistor radiator                                                                                                                                                                 |
| 7n11 | SPN_n_ : OVERVOLT POW CIRCUIT      | 11                 | 1 Check the selected PSM.<br>2 Check the input power voltage and change in power during motor deceleration. If the voltage exceeds 253 VAC (for the 200-V system) or 530 VAC (for the 400-V system), improve the power supply impedance. | Overvoltage of the DC link section of the PSM was detected. (PSM alarm indication: 7)<br>PSM selection error. (The maximum output specification of the PSM is exceeded.)                                                   |
| 7n12 | SPN_n_ : OVERCURRENT POW CIRCUIT   | 12                 | 1 Check the motor insulation status.<br>2 Check the spindle parameters.<br>3 Replace the SPM unit.                                                                                                                                       | The motor output current is abnormally high.<br>A motor-specific parameter does not match the motor model.<br>Poor motor insulation                                                                                        |
| 7n15 | SPN_n_ : SP SWITCH CONTROL ALARM   | 15                 | 1 Check and correct the ladder sequence.<br>2 Replace the switching MC.                                                                                                                                                                  | The switch sequence in spindle switch/output switch operation is abnormal.<br>The switching MC contact status check signal and command do not match.                                                                       |
| 7n16 | SPN_n_ : RAM FAULT                 | 16                 | Replace the SPM control printed circuit board.                                                                                                                                                                                           | Abnormality in an SPM control circuit component is detected. (RAM for external data is abnormal.)                                                                                                                          |
| 7n18 | SPN_n_ : SUMCHECK ERROR PGM DATA   | 18                 | Replace the SPM control printed circuit board.                                                                                                                                                                                           | Abnormality in an SPM control circuit component is detected. (Program ROM data is abnormal.)                                                                                                                               |
| 7n19 | SPN_n_ : EX OFFSET CURRENT U       | 19                 | Replace the SPM unit.                                                                                                                                                                                                                    | Abnormality in an SPM component is detected. (The initial value for the U phase current detection circuit is abnormal.)                                                                                                    |
| 7n20 | SPN_n_ : EX OFFSET CURRENT V       | 20                 | Replace the SPM unit.                                                                                                                                                                                                                    | Abnormality in an SPM component is detected. (The initial value of the V phase current detection circuit is abnormal.)                                                                                                     |
| 7n21 | SPN_n_ : POS SENSOR POLARITY ERROR | 21                 | Check and correct the parameters. (No. 4000#0, 4001#4)                                                                                                                                                                                   | The polarity parameter setting of the position sensor is wrong.                                                                                                                                                            |



| No.  | Message                           | SPM indication(*1) | Faulty location and remedy                                                             | Description                                                                                                                                                                                                   |
|------|-----------------------------------|--------------------|----------------------------------------------------------------------------------------|---------------------------------------------------------------------------------------------------------------------------------------------------------------------------------------------------------------|
| 7n24 | SPN_n_ : SERIAL TRANSFER ERROR    | 24                 | 1 Place the CNC-to-spindle cable away from the power cable.<br>2 Replace the cable.    | The CNC power is turned off (normal power-off or broken cable). An error is detected in communication data transferred to the CNC.                                                                            |
| 7n26 | SPN_n_ : DISCONNECT C-VELO DETECT | 26                 | 1 Replace the cable.<br>2 Re-adjust the pre-amplifier.                                 | The signal amplitude of the detection signal (connector JY2) on the Cs contour control motor side is abnormal. (Unconnected cable, adjustment error, etc.)                                                    |
| 7n27 | SPN_n_ : DISCONNECT POS-CODER     | 27                 | 1 Replace the cable.<br>2 Re-adjust the BZ sensor signal.                              | 1 The spindle position coder (connector JY4) signal is abnormal.<br>2 The signal amplitude (connector JY2) of the MZ or BZ sensor is abnormal. (Unconnected cable, adjustment error, etc.)                    |
| 7n28 | SPN_n_ : DISCONNECT C-POS DETECT  | 28                 | 1 Replace the cable<br>2 Re-adjust the pre-amplifier.                                  | The position detection signal (connector JY5) for Cs contour control is abnormal. (Unconnected cable, adjustment error, etc.)                                                                                 |
| 7n29 | SPN_n_ : SHORTTIME OVERLOAD       | 29                 | Check and correct the load status.                                                     | Excessive load has been applied continuously for a certain period of time. (This alarm is issued also when the motor shaft has been locked in the excitation state.)                                          |
| 7n30 | SPN_n_ : OVERCURRENT POW CIRCUIT  | 30                 | Check and correct the power supply voltage.                                            | Overcurrent is detected in PSM main circuit input. (PSM alarm indication: 1)<br>Unbalanced power supply.<br>PSM selection error (The maximum PSM output specification is exceeded.)                           |
| 7n31 | SPN_n_ : MOTOR LOCK OR V-SIG LOS  | 31                 | 1 Check and correct the load status.<br>2 Replace the motor sensor cable (JY2 or JY5). | The motor cannot rotate at a specified speed. (A level not exceeding the SST level for the rotation command has existed continuously.)<br>Abnormality in the speed detection signal.                          |
| 7n32 | SPN_n_ : RAM FAULT SERIAL LSI     | 32                 | Replace the SPM control printed circuit board.                                         | Abnormality in an SPM control circuit component is detected. (The LSI device for serial transfer is abnormal.)                                                                                                |
| 7n33 | SPN_n_ : SHORTAGE POWER CHARGE    | 33                 | 1 Check and correct the power supply voltage.<br>2 Replace the PSM unit.               | Charging of direct current power supply voltage in the power circuit section is insufficient when the magnetic contractor in the amplifier is turned on (such as open phase and defective charging resistor). |

| No.  | Message                               | SPM indication(*1) | Faulty location and remedy                                                                                                                                    | Description                                                                                                                                                                                    |
|------|---------------------------------------|--------------------|---------------------------------------------------------------------------------------------------------------------------------------------------------------|------------------------------------------------------------------------------------------------------------------------------------------------------------------------------------------------|
| 7n34 | SPN_n_ : PARAMETER SETTING ERROR      | 34                 | Correct a parameter value according to the manual.<br>If the parameter number is unknown, connect the spindle check board, and check the indicated parameter. | Parameter data exceeding the allowable limit is set.                                                                                                                                           |
| 7n35 | SPN_n_ : EX SETTING GEAR RATIO        | 35                 | Correct the value according to the parameter manual.                                                                                                          | Gear ratio data exceeding the allowable limit is set.                                                                                                                                          |
| 7n36 | SPN_n_ : OVERFLOW ERROR COUNTER       | 36                 | Check whether the position gain value is too large, and correct the value.                                                                                    | An error counter overflow occurred.                                                                                                                                                            |
| 7n37 | SPN_n_ : SPEED DETECT PAR. ERROR      | 37                 | Correct the value according to the parameter manual.                                                                                                          | The setting of the parameter for the number of pulses in the speed detector is incorrect.                                                                                                      |
| 7n39 | SPN_n_ : 1-ROT Cs SIGNAL ERROR        | 39                 | 1 Adjust the 1-rotation signal in the pre-amplifier.<br>2 Check the cable shield status.<br>3 Replace the cable.                                              | An incorrect relationship between the 1-rotation signal and the number of AB phase pulses was detected during Cs contour control.                                                              |
| 7n40 | SPN_n_ : NO 1-ROT Cs SIGNAL DETECT    | 40                 | 1 Adjust the 1-rotation signal in the pre-amplifier.<br>2 Check the cable shield status.<br>3 Replace the cable.                                              | The 1-rotation signal is not generated during Cs contour control.                                                                                                                              |
| 7n41 | SPN_n_ : 1-ROT POS-CODER ERROR        | 41                 | 1 Check and correct the parameter.<br>2 Replace the cable.<br>3 Re-adjust the BZ sensor signal.                                                               | 1 The 1-rotation signal of the spindle position coder (connector JY4) is abnormal.<br>2 The 1-rotation signal (connector JY2) of the MZ or BZ sensor is abnormal.<br>3 Parameter setting error |
| 7n42 | SPN_n_ : NO 1-ROT. POS-CODER DETECT   | 42                 | 1 Replace the cable.<br>2 Re-adjust the BZ sensor signal.                                                                                                     | 1 The 1-rotation signal of the spindle position coder (connector JY4) is disconnected.<br>2 The 1-rotation signal (connector JY2) of the MZ or BZ sensor is disconnected.                      |
| 7n43 | SPN_n_ : DISCON. PC FOR DIF. SP. MODE | 43                 | Replace the cable.                                                                                                                                            | The differential speed position coder signal (connector JY8) in SPM type 3 is abnormal.                                                                                                        |
| 7n44 | SPN_n_ : CONTROL CIRCUIT(AD) ERROR    | 44                 | Replace the SPM control printed circuit board.                                                                                                                | Abnormality in an SPM control circuit component was detected (A/D converter abnormality).                                                                                                      |
| 7n46 | SPN_n_ : SCREW 1-ROT POS-COD. ALARM   | 46                 | 1 Check and correct the parameter.<br>2 Replace the cable.<br>3 Re-adjust the BZ sensor signal.                                                               | An abnormality equivalent to alarm 41 was detected during thread cutting operation.                                                                                                            |

| No.  | Message                            | SPM indication(*1) | Faulty location and remedy                                                                                                                                                                                                                                                                   | Description                                                                                                                                                                                                                                                                                                                         |
|------|------------------------------------|--------------------|----------------------------------------------------------------------------------------------------------------------------------------------------------------------------------------------------------------------------------------------------------------------------------------------|-------------------------------------------------------------------------------------------------------------------------------------------------------------------------------------------------------------------------------------------------------------------------------------------------------------------------------------|
| 7n47 | SPN_n_ : POS-CODER SIGNAL ABNORMAL | 47                 | <ol style="list-style-type: none"> <li>1 Replace the cable.</li> <li>2 Re-adjust the BZ sensor signal.</li> <li>3 Correct the cable layout (vicinity of the power line).</li> </ol>                                                                                                          | <ol style="list-style-type: none"> <li>1 The A/B phase signal of the spindle position coder (connector JY4) is abnormal.</li> <li>2 The A/B phase signal (connector JY2) of the MZ or BZ sensor is abnormal.</li> </ol> <p>The relationship between the A/B phase and 1-rotation signal is incorrect (Pulse interval mismatch).</p> |
| 7n49 | SPN_n_ : HIGH CONV. DIF. SPEED     | 49                 | Check whether the calculated differential speed value exceeds the maximum motor speed.                                                                                                                                                                                                       | In differential speed mode, the speed of the other spindle converted to the speed of the local spindle has exceeded the allowable limit (the differential speed is calculated by multiplying the speed of the other spindle by the gear ratio).                                                                                     |
| 7n50 | SPN_n_ : SPNDL CONTROL OVERSPEED   | 50                 | Check whether the calculated value exceeds the maximum motor speed.                                                                                                                                                                                                                          | In spindle synchronization, the speed command calculation value exceeded the allowable limit (the motor speed is calculated by multiplying the specified spindle speed by the gear ratio).                                                                                                                                          |
| 7n51 | SPN_n_ : LOW VOLT DC LINK          | 51                 | <ol style="list-style-type: none"> <li>1 Check and correct the power supply voltage.</li> <li>2 Replace the MC.</li> </ol>                                                                                                                                                                   | Input voltage drop was detected. (PSM alarm indication: 4) (Momentary power failure or poor MC contact)                                                                                                                                                                                                                             |
| 7n52 | SPN_n_ : ITP SIGNAL ABNORMAL I     | 52                 | <ol style="list-style-type: none"> <li>1 Replace the SPM control printed circuit board.</li> <li>2 Replace the spindle interface printed circuit board in the CNC.</li> </ol>                                                                                                                | NC interface abnormality was detected (the ITP signal stopped).                                                                                                                                                                                                                                                                     |
| 7n53 | SPN_n_ : ITP SIGNAL ABNORMAL II    | 53                 | <ol style="list-style-type: none"> <li>1 Replace the SPM control printed circuit board.</li> <li>2 Replace the spindle interface printed circuit board in the CNC.</li> </ol>                                                                                                                | NC interface abnormality was detected (the ITP signal stopped).                                                                                                                                                                                                                                                                     |
| 7n54 | SPN_n_ : OVERLOAD CURRENT          | 54                 | Review the load state.                                                                                                                                                                                                                                                                       | An overload current was detected.                                                                                                                                                                                                                                                                                                   |
| 7n55 | SPN_n_ : POWER LINE SWITCH ERROR   | 55                 | <ol style="list-style-type: none"> <li>1 Replace the magnetic contactor.</li> <li>2 Check and correct the sequence.</li> </ol>                                                                                                                                                               | The power line state signal of the magnetic contactor for selecting a spindle or output is abnormal.                                                                                                                                                                                                                                |
| 7n56 | SPN_n_ : INNER COOLING FAN STOP    | 56                 | Replace the SPM unit.                                                                                                                                                                                                                                                                        | The cooling fan in the SPM control circuit stopped.                                                                                                                                                                                                                                                                                 |
| 7n57 | SPN_n_ : EX DECELERATION POWER     | 57                 | <ol style="list-style-type: none"> <li>1 Decrease the acceleration/deceleration duty.</li> <li>2 Check the cooling condition (peripheral temperature).</li> <li>3 If the cooling fan stops, replace the resistor.</li> <li>4 If the resistance is abnormal, replace the resistor.</li> </ol> | <p>An overload was detected in the regenerative resistance. (PSMR alarm indication: 8)</p> <p>Thermostat operation or short-time overload was detected.</p> <p>The regenerative resistor was disconnected, or an abnormal resistance was detected.</p>                                                                              |

| No.  | Message                            | SPM indication(*1) | Faulty location and remedy                                                                                                                                           | Description                                                                                    |
|------|------------------------------------|--------------------|----------------------------------------------------------------------------------------------------------------------------------------------------------------------|------------------------------------------------------------------------------------------------|
| 7n58 | SPN_n_ : OVERLOAD IN PSM           | 58                 | 1 Check the PSM cooling status.<br>2 Replace the PSM unit.                                                                                                           | The temperature of the radiator of the PSM has increased abnormally. (PSM alarm indication: 3) |
| 7n59 | SPN_n_ : COOLING FAN STOP IN PSM   | 59                 | Replace the SPM unit.                                                                                                                                                | The cooling fan in the PSM stopped. (PSM alarm indication: 2)                                  |
| 7n62 | SPN_n_ : MOTOR VCMD OVERFLOWED     | 62                 | Check and correct the parameters. (No. 4021, 4056 to 4059)                                                                                                           | The specified motor speed is too large.                                                        |
| 7n66 | SPN_n_ : AMP MODULE COMMUNICATION  | 66                 | 1 Replace the cable.<br>2 Check and correct the connection.                                                                                                          | An error was found in communication between amplifiers.                                        |
| 7n73 | SPN_n_ : MOTOR SENSOR DISCONNECTED | 73                 | 1 Replace the feedback cable.<br>2 Check the shield processing.<br>3 Check and correct the connection.<br>4 Adjust the sensor.                                       | The motor sensor feedback signal is not present.                                               |
| 7n74 | SPN_n_ : CPU TEST ERROR            | 74                 | Replace the SPM control printed-circuit board.                                                                                                                       | An error was detected in a CPU test.                                                           |
| 7n75 | SPN_n_ : CRC ERROR                 | 75                 | Replace the SPM control printed-circuit board.                                                                                                                       | An error was detected in a CRC test.                                                           |
| 7n79 | SPN_n_ : INITIAL TEST ERROR        | 79                 | Replace the SPM control printed-circuit board.                                                                                                                       | An error was detected in an initial test operation.                                            |
| 7n81 | SPN_n_ : 1-ROT MOTOR SENSOR ERROR  | 81                 | 1 Check and correct the parameter.<br>2 Replace the feedback cable.<br>3 Adjust the sensor.                                                                          | The one-rotation signal of the motor sensor cannot be correctly detected.                      |
| 7n82 | SPN_n_ : NO 1-ROT MOTOR SENSOR     | 82                 | 1 Replace the feedback cable.<br>2 Adjust the sensor.                                                                                                                | The one-rotation signal of the motor sensor is not generated.                                  |
| 7n83 | SPN_n_ : MOTOR SENSOR SIGNAL ERROR | 83                 | 1 Replace the feedback cable.<br>2 Adjust the sensor.                                                                                                                | An irregularity was detected in a motor sensor feedback signal.                                |
| 7n84 | SPN_n_ : SPNDL SENSOR DISCONNECTED | 84                 | 1 Replace the feedback cable.<br>2 Check the shield processing.<br>3 Check and correct the connection.<br>4 Check and correct the parameter.<br>5 Adjust the sensor. | The spindle sensor feedback signal is not present.                                             |
| 7n85 | SPN_n_ : 1-ROT SPNDL SENSOR ERROR  | 85                 | 1 Check and correct the parameter.<br>2 Replace the feedback cable.<br>3 Adjust the sensor.                                                                          | The one-rotation signal of the spindle sensor cannot be correctly detected.                    |
| 7n87 | SPN_n_ : SPNDL SENSOR SIGNAL ERROR | 87                 | The one-rotation signal of the spindle sensor is not generated.                                                                                                      | An irregularity was detected in a spindle sensor feedback signal.                              |
| 7n88 | SPN_n_ : COOLING RADIFAN FAILURE   | 88                 | Replace the SPM external cooling fan.                                                                                                                                | The external cooling fan stopped.                                                              |

| No.  | Message                        | SPM indication(*1) | Faulty location and remedy   | Description                        |
|------|--------------------------------|--------------------|------------------------------|------------------------------------|
| 7n97 | SPN_n_ : OTHER SPINDLE ALARM   | 97                 | Replace the SPM.             | Another irregularity was detected. |
| 7n98 | SPN_n_ : OTHER CONVERTER ALARM | 98                 | Check the PSM alarm display. | A PSM alarm was detected.          |

| No.  | Message                        | SPM indication(*1) | Faulty location and remedy                                                                                                                                         | Description                                                                                                                                                                                                                                                               |
|------|--------------------------------|--------------------|--------------------------------------------------------------------------------------------------------------------------------------------------------------------|---------------------------------------------------------------------------------------------------------------------------------------------------------------------------------------------------------------------------------------------------------------------------|
| 9n01 | SPN_n_ : MOTOR OVERHEAT        | 01                 | <ol style="list-style-type: none"> <li>1 Check and correct the peripheral temperature and load status.</li> <li>2 If the cooling fan stops, replace it.</li> </ol> | <p>The thermostat embedded in the motor winding operated.</p> <p>The internal temperature of the motor exceeds the specified level.</p> <p>The motor is used in excess of the continuous rating, or the cooling component is abnormal.</p>                                |
| 9n02 | SPN_n_ : EX SPEED ERROR        | 02                 | <ol style="list-style-type: none"> <li>1 Check and correct the cutting conditions to decrease the load.</li> <li>2 Correct parameter No. 4082.</li> </ol>          | <p>The motor speed cannot follow a specified speed.</p> <p>An excessive motor load torque is detected.</p> <p>The acceleration/deceleration time in parameter No. 4082 is insufficient.</p>                                                                               |
| 9n03 | SPN_n_ : FUSE ON DC LINK BLOWN | 03                 | <ol style="list-style-type: none"> <li>1 Replace the SPM unit.</li> <li>2 Check the motor insulation status.</li> <li>3 Replace the interface cable.</li> </ol>    | <p>The PSM becomes ready (00 is indicated), but the DC link voltage is too low in the SPM.</p> <p>The fuse in the DC link section in the SPM is blown. (The power device is damaged or the motor is ground-fault.)</p> <p>The JX1A/JX1B connection cable is abnormal.</p> |
| 9n06 |                                | 06                 | <ol style="list-style-type: none"> <li>1 Check and correct the parameter.</li> <li>2 Replace the feedback cable.</li> </ol>                                        | <p>The temperature sensor of the motor is disconnected.</p>                                                                                                                                                                                                               |
| 9n07 | SPN_n_ : OVERSPEED             | 07                 | <p>Check for a sequence error. (For example, check whether spindle synchronization was specified when the spindle could not be turned.)</p>                        | <p>The motor speed has exceeded 115% of its rated speed.</p> <p>When the spindle axis was in position control mode, positional deviations were accumulated excessively (SFR and SRV were turned off during spindle synchronization.)</p>                                  |
| 9n09 | SPN_n_ : OVERHEAT MAIN CIRCUIT | 09                 | <ol style="list-style-type: none"> <li>1 Improve the heat sink cooling status.</li> <li>2 If the heat sink cooling fan stops, replace the SPM unit.</li> </ol>     | <p>Abnormal temperature rise of the power transistor radiator</p>                                                                                                                                                                                                         |

| No.  | Message                                   | SPM indication(*1) | Faulty location and remedy                                                                                                                                                                                                               | Description                                                                                                                                                              |
|------|-------------------------------------------|--------------------|------------------------------------------------------------------------------------------------------------------------------------------------------------------------------------------------------------------------------------------|--------------------------------------------------------------------------------------------------------------------------------------------------------------------------|
| 9n11 | SPN_n_ : OVERVOLT<br>POW CIRCUIT          | 11                 | 1 Check the selected PSM.<br>2 Check the input power voltage and change in power during motor deceleration. If the voltage exceeds 253 VAC (for the 200-V system) or 530 VAC (for the 400-V system), improve the power supply impedance. | Overvoltage of the DC link section of the PSM was detected. (PSM alarm indication: 7)<br>PSM selection error. (The maximum output specification of the PSM is exceeded.) |
| 9n12 | SPN_n_ : OVERCURRENT<br>POW CIRCUIT       | 12                 | 1 Check the motor insulation status.<br>2 Check the spindle parameters.<br>3 Replace the SPM unit.                                                                                                                                       | The motor output current is abnormally high.<br>A motor-specific parameter does not match the motor model.<br>Poor motor insulation                                      |
| 9n15 | SPN_n_ : SP SWITCH<br>CONTROL<br>ALARM    | 15                 | 1 Check and correct the ladder sequence.<br>2 Replace the switching MC.                                                                                                                                                                  | The switch sequence in spindle switch/output switch operation is abnormal.<br>The switching MC contact status check signal and command do not match.                     |
| 9n16 | SPN_n_ : RAM FAULT                        | 16                 | Replace the SPM control printed circuit board.                                                                                                                                                                                           | Abnormality in an SPM control circuit component is detected. (RAM for external data is abnormal.)                                                                        |
| 9n18 | SPN_n_ : SUMCHECK<br>ERROR PGM<br>DATA    | 18                 | Replace the SPM control printed circuit board.                                                                                                                                                                                           | Abnormality in an SPM control circuit component is detected. (Program ROM data is abnormal.)                                                                             |
| 9n19 | SPN_n_ : EX OFFSET<br>CURRENT U           | 19                 | Replace the SPM unit.                                                                                                                                                                                                                    | Abnormality in an SPM component is detected. (The initial value for the U phase current detection circuit is abnormal.)                                                  |
| 9n20 | SPN_n_ : EX OFFSET<br>CURRENT V           | 20                 | Replace the SPM unit.                                                                                                                                                                                                                    | Abnormality in an SPM component is detected. (The initial value of the V phase current detection circuit is abnormal.)                                                   |
| 9n21 | SPN_n_ : POS SENSOR<br>POLARITY ERROR     | 21                 | Check and correct the parameters. (No. 4000#0, 4001#4)                                                                                                                                                                                   | The polarity parameter setting of the position sensor is wrong.                                                                                                          |
| 9n24 | SPN_n_ : SERIAL<br>TRANSFER<br>ERROR      | 24                 | 1 Place the CNC-to-spindle cable away from the power cable.<br>2 Replace the cable.                                                                                                                                                      | The CNC power is turned off (normal power-off or broken cable).<br>An error is detected in communication data transferred to the CNC.                                    |
| 9n26 | SPN_n_ : DISCONNECT<br>C-VELO DE-<br>TECT | 26                 | 1 Replace the cable.<br>2 Re-adjust the pre-amplifier.                                                                                                                                                                                   | The signal amplitude of the detection signal (connector JY2) on the Cs contour control motor side is abnormal. (Unconnected cable, adjustment error, etc.)               |

| No.  | Message                          | SPM indication(*1) | Faulty location and remedy                                                                                                                                    | Description                                                                                                                                                                                                   |
|------|----------------------------------|--------------------|---------------------------------------------------------------------------------------------------------------------------------------------------------------|---------------------------------------------------------------------------------------------------------------------------------------------------------------------------------------------------------------|
| 9n27 | SPN_n_ : DISCONNECT POS-CODER    | 27                 | 1 Replace the cable.<br>2 Re-adjust the BZ sensor signal.                                                                                                     | 1 The spindle position coder (connector JY4) signal is abnormal.<br>2 The signal amplitude (connector JY2) of the MZ or BZ sensor is abnormal.<br>(Unconnected cable, adjustment error, etc.)                 |
| 9n28 | SPN_n_ : DISCONNECT C-POS DETECT | 28                 | 1 Replace the cable<br>2 Re-adjust the pre-amplifier.                                                                                                         | The position detection signal (connector JY5) for Cs contour control is abnormal.<br>(Unconnected cable, adjustment error, etc.)                                                                              |
| 9n29 | SPN_n_ : SHORTTIME OVERLOAD      | 29                 | Check and correct the load status.                                                                                                                            | Excessive load has been applied continuously for a certain period of time. (This alarm is issued also when the motor shaft has been locked in the excitation state.)                                          |
| 9n30 | SPN_n_ : OVERCURRENT POW CIRCUIT | 30                 | Check and correct the power supply voltage.                                                                                                                   | Overcurrent is detected in PSM main circuit input. (PSM alarm indication: 1)<br>Unbalanced power supply.<br>PSM selection error (The maximum PSM output specification is exceeded.)                           |
| 9n31 | SPN_n_ : MOTOR LOCK OR V-SIG LOS | 31                 | 1 Check and correct the load status.<br>2 Replace the motor sensor cable (JY2 or JY5).                                                                        | The motor cannot rotate at a specified speed. (A level not exceeding the SST level for the rotation command has existed continuously.)<br>Abnormality in the speed detection signal.                          |
| 9n32 | SPN_n_ : RAM FAULT SERIAL LSI    | 32                 | Replace the SPM control printed circuit board.                                                                                                                | Abnormality in an SPM control circuit component is detected. (The LSI device for serial transfer is abnormal.)                                                                                                |
| 9n33 | SPN_n_ : SHORTAGE POWER CHARGE   | 33                 | 1 Check and correct the power supply voltage.<br>2 Replace the PSM unit.                                                                                      | Charging of direct current power supply voltage in the power circuit section is insufficient when the magnetic contractor in the amplifier is turned on (such as open phase and defective charging resistor). |
| 9n34 | SPN_n_ : PARAMETER SETTING ERROR | 34                 | Correct a parameter value according to the manual.<br>If the parameter number is unknown, connect the spindle check board, and check the indicated parameter. | Parameter data exceeding the allowable limit is set.                                                                                                                                                          |
| 9n35 | SPN_n_ : EX SETTING GEAR RATIO   | 35                 | Correct the value according to the parameter manual.                                                                                                          | Gear ratio data exceeding the allowable limit is set.                                                                                                                                                         |
| 9n36 | SPN_n_ : OVERFLOW ERROR COUNTER  | 36                 | Check whether the position gain value is too large, and correct the value.                                                                                    | An error counter overflow occurred.                                                                                                                                                                           |

| No.  | Message                               | SPM indication(*1) | Faulty location and remedy                                                                                                                                                          | Description                                                                                                                                                                                                                                                                                                                         |
|------|---------------------------------------|--------------------|-------------------------------------------------------------------------------------------------------------------------------------------------------------------------------------|-------------------------------------------------------------------------------------------------------------------------------------------------------------------------------------------------------------------------------------------------------------------------------------------------------------------------------------|
| 9n37 | SPN_n_ : SPEED DETECT PAR. ERROR      | 37                 | Correct the value according to the parameter manual.                                                                                                                                | The setting of the parameter for the number of pulses in the speed detector is incorrect.                                                                                                                                                                                                                                           |
| 9n39 | SPN_n_ : 1-ROT Cs SIGNAL ERROR        | 39                 | <ol style="list-style-type: none"> <li>1 Adjust the 1-rotation signal in the pre-amplifier.</li> <li>2 Check the cable shield status.</li> <li>3 Replace the cable.</li> </ol>      | An incorrect relationship between the 1-rotation signal and the number of AB phase pulses was detected during Cs contour control.                                                                                                                                                                                                   |
| 9n40 | SPN_n_ : NO 1-ROT Cs SIGNAL DETECT    | 40                 | <ol style="list-style-type: none"> <li>1 Adjust the 1-rotation signal in the pre-amplifier.</li> <li>2 Check the cable shield status.</li> <li>3 Replace the cable.</li> </ol>      | The 1-rotation signal is not generated during Cs contour control.                                                                                                                                                                                                                                                                   |
| 9n41 | SPN_n_ : 1-ROT POS-CODER ERROR        | 41                 | <ol style="list-style-type: none"> <li>1 Check and correct the parameter.</li> <li>2 Replace the cable.</li> <li>3 Re-adjust the BZ sensor signal.</li> </ol>                       | <ol style="list-style-type: none"> <li>1 The 1-rotation signal of the spindle position coder (connector JY4) is abnormal.</li> <li>2 The 1-rotation signal (connector JY2) of the MZ or BZ sensor is abnormal.</li> <li>3 Parameter setting error</li> </ol>                                                                        |
| 9n42 | SPN_n_ : NO 1-ROT. POS-CODER DETECT   | 42                 | <ol style="list-style-type: none"> <li>1 Replace the cable.</li> <li>2 Re-adjust the BZ sensor signal.</li> </ol>                                                                   | <ol style="list-style-type: none"> <li>1 The 1-rotation signal of the spindle position coder (connector JY4) is disconnected.</li> <li>2 The 1-rotation signal (connector JY2) of the MZ or BZ sensor is disconnected.</li> </ol>                                                                                                   |
| 9n43 | SPN_n_ : DISCON. PC FOR DIF. SP. MODE | 43                 | Replace the cable.                                                                                                                                                                  | The differential speed position coder signal (connector JY8) in SPM type 3 is abnormal.                                                                                                                                                                                                                                             |
| 9n44 | SPN_n_ : CONTROL CIRCUIT(AD) ERROR    | 44                 | Replace the SPM control printed circuit board.                                                                                                                                      | Abnormality in an SPM control circuit component was detected (A/D converter abnormality).                                                                                                                                                                                                                                           |
| 9n46 | SPN_n_ : SCREW 1-ROT POS-COD. ALARM   | 46                 | <ol style="list-style-type: none"> <li>1 Check and correct the parameter.</li> <li>2 Replace the cable.</li> <li>3 Re-adjust the BZ sensor signal.</li> </ol>                       | An abnormality equivalent to alarm 41 was detected during thread cutting operation.                                                                                                                                                                                                                                                 |
| 9n47 | SPN_n_ : POS-CODER SIGNAL ABNORMAL    | 47                 | <ol style="list-style-type: none"> <li>1 Replace the cable.</li> <li>2 Re-adjust the BZ sensor signal.</li> <li>3 Correct the cable layout (vicinity of the power line).</li> </ol> | <ol style="list-style-type: none"> <li>1 The A/B phase signal of the spindle position coder (connector JY4) is abnormal.</li> <li>2 The A/B phase signal (connector JY2) of the MZ or BZ sensor is abnormal.</li> </ol> <p>The relationship between the A/B phase and 1-rotation signal is incorrect (Pulse interval mismatch).</p> |
| 9n49 | SPN_n_ : HIGH CONV. DIF. SPEED        | 49                 | Check whether the calculated differential speed value exceeds the maximum motor speed.                                                                                              | In differential speed mode, the speed of the other spindle converted to the speed of the local spindle has exceeded the allowable limit (the differential speed is calculated by multiplying the speed of the other spindle by the gear ratio).                                                                                     |



| No.  | Message                            | SPM indication(*1) | Faulty location and remedy                                                                                                                                                                                               | Description                                                                                                                                                                                                                             |
|------|------------------------------------|--------------------|--------------------------------------------------------------------------------------------------------------------------------------------------------------------------------------------------------------------------|-----------------------------------------------------------------------------------------------------------------------------------------------------------------------------------------------------------------------------------------|
| 9n50 | SPN_n_ : SPNDL CONTROL OVER-SPEED  | 50                 | Check whether the calculated value exceeds the maximum motor speed.                                                                                                                                                      | In spindle synchronization, the speed command calculation value exceeded the allowable limit (the motor speed is calculated by multiplying the specified spindle speed by the gear ratio).                                              |
| 9n51 | SPN_n_ : LOW VOLT DC LINK          | 51                 | 1 Check and correct the power supply voltage.<br>2 Replace the MC.                                                                                                                                                       | Input voltage drop was detected. (PSM alarm indication: 4) (Momentary power failure or poor MC contact)                                                                                                                                 |
| 9n52 | SPN_n_ : ITP SIGNAL ABNORMAL I     | 52                 | 1 Replace the SPM control printed circuit board.<br>2 Replace the spindle interface printed circuit board in the CNC.                                                                                                    | NC interface abnormality was detected (the ITP signal stopped).                                                                                                                                                                         |
| 9n53 | SPN_n_ : ITP SIGNAL ABNORMAL II    | 53                 | 1 Replace the SPM control printed circuit board.<br>2 Replace the spindle interface printed circuit board in the CNC.                                                                                                    | NC interface abnormality was detected (the ITP signal stopped).                                                                                                                                                                         |
| 9n54 | SPN_n_ : OVERLOAD CURRENT          | 54                 | Review the load state.                                                                                                                                                                                                   | An overload current was detected.                                                                                                                                                                                                       |
| 9n55 | SPN_n_ : POWER LINE SWITCH ERROR   | 55                 | 1 Replace the magnetic contactor.<br>2 Check and correct the sequence.                                                                                                                                                   | The power line state signal of the magnetic contactor for selecting a spindle or output is abnormal.                                                                                                                                    |
| 9n56 | SPN_n_ : INNER COOLING FAN STOP    | 56                 | Replace the SPM unit.                                                                                                                                                                                                    | The cooling fan in the SPM control circuit stopped.                                                                                                                                                                                     |
| 9n57 | SPN_n_ : EX DECELERATION POWER     | 57                 | 1 Decrease the acceleration/deceleration duty.<br>2 Check the cooling condition (peripheral temperature).<br>3 If the cooling fan stops, replace the resistor.<br>4 If the resistance is abnormal, replace the resistor. | An overload was detected in the regenerative resistance. (PSMR alarm indication: 8)<br>Thermostat operation or short-time overload was detected.<br>The regenerative resistor was disconnected, or an abnormal resistance was detected. |
| 9n58 | SPN_n_ : OVERLOAD IN PSM           | 58                 | 1 Check the PSM cooling status.<br>2 Replace the PSM unit.                                                                                                                                                               | The temperature of the radiator of the PSM has increased abnormally. (PSM alarm indication: 3)                                                                                                                                          |
| 9n59 | SPN_n_ : COOLING FAN STOP IN PSM   | 59                 | Replace the SPM unit.                                                                                                                                                                                                    | The cooling fan in the PSM stopped. (PSM alarm indication: 2)                                                                                                                                                                           |
| 9n62 | SPN_n_ : MOTOR VCMD OVERFLOWED     | 62                 | Check and correct the parameters. (No. 4021, 4056~4059)                                                                                                                                                                  | The specified motor speed is too large.                                                                                                                                                                                                 |
| 9n66 | SPN_n_ : AMP MODULE COMMUNICATION  | 66                 | 1 Replace the cable.<br>2 Check and correct the connection.                                                                                                                                                              | An error was found in communication between amplifiers.                                                                                                                                                                                 |
| 9n73 | SPN_n_ : MOTOR SENSOR DISCONNECTED | 73                 | 1 Replace the feedback cable.<br>2 Check the shield processing.<br>3 Check and correct the connection.<br>4 Adjust the sensor.                                                                                           | The motor sensor feedback signal is not present.                                                                                                                                                                                        |

| No.  | Message                            | SPM indication(*1) | Faulty location and remedy                                                                                                                                           | Description                                                                 |
|------|------------------------------------|--------------------|----------------------------------------------------------------------------------------------------------------------------------------------------------------------|-----------------------------------------------------------------------------|
| 9n74 | SPN_n_ : CPU TEST ERROR            | 74                 | Replace the SPM control printed-circuit board.                                                                                                                       | An error was detected in a CPU test.                                        |
| 9n75 | SPN_n_ : CRC ERROR                 | 75                 | Replace the SPM control printed-circuit board.                                                                                                                       | An error was detected in a CRC test.                                        |
| 9n79 | SPN_n_ : INITIAL TEST ERROR        | 79                 | Replace the SPM control printed-circuit board.                                                                                                                       | An error was detected in an initial test operation.                         |
| 9n81 | SPN_n_ : 1-ROT MOTOR SENSOR ERROR  | 81                 | 1 Check and correct the parameter.<br>2 Replace the feedback cable.<br>3 Adjust the sensor.                                                                          | The one-rotation signal of the motor sensor cannot be correctly detected.   |
| 9n82 | SPN_n_ : NO 1-ROT MOTOR SENSOR     | 82                 | 1 Replace the feedback cable.<br>2 Adjust the sensor.                                                                                                                | The one-rotation signal of the motor sensor is not generated.               |
| 9n83 | SPN_n_ : MOTOR SENSOR SIGNAL ERROR | 83                 | 1 Replace the feedback cable.<br>2 Adjust the sensor.                                                                                                                | An irregularity was detected in a motor sensor feedback signal.             |
| 9n84 | SPN_n_ : SPNDL SENSOR DISCONNECTED | 84                 | 1 Replace the feedback cable.<br>2 Check the shield processing.<br>3 Check and correct the connection.<br>4 Check and correct the parameter.<br>5 Adjust the sensor. | The spindle sensor feedback signal is not present.                          |
| 9n85 | SPN_n_ : 1-ROT SPNDL SENSOR ERROR  | 85                 | 1 Check and correct the parameter.<br>2 Replace the feedback cable.<br>3 Adjust the sensor.                                                                          | The one-rotation signal of the spindle sensor cannot be correctly detected. |
| 9n87 | SPN_n_ : SPNDL SENSOR SIGNAL ERROR | 87                 | The one-rotation signal of the spindle sensor is not generated.                                                                                                      | An irregularity was detected in a spindle sensor feedback signal.           |
| 9n88 | SPN_n_ : COOLING RADIFAN FAILURE   | 88                 | Replace the SPM external cooling fan.                                                                                                                                | The external cooling fan stopped.                                           |

## 10) System alarms

(These alarms cannot be reset with reset key.)

| Number | Message                      | Contents                                                                                                                                                                                          |
|--------|------------------------------|---------------------------------------------------------------------------------------------------------------------------------------------------------------------------------------------------|
| 900    | ROM PARITY                   | A parity error occurred in the CNC, macro, or servo ROM. Correct the contents of the flash ROM having the displayed number.                                                                       |
| 910    | SRAM PARITY : (BYTE 0)       | A RAM parity error occurred in the part program storage RAM. Clear the RAM, or replace the SRAM module or motherboard. Subsequently, re-set the parameters and all other data.                    |
| 911    | SRAM PARITY : (BYTE 1)       |                                                                                                                                                                                                   |
| 912    | DRAM PARITY : (BYTE 0)       |                                                                                                                                                                                                   |
| 913    | DRAM PARITY : (BYTE 1)       |                                                                                                                                                                                                   |
| 914    | DRAM PARITY : (BYTE 2)       |                                                                                                                                                                                                   |
| 915    | DRAM PARITY : (BYTE 3)       |                                                                                                                                                                                                   |
| 916    | DRAM PARITY : (BYTE 4)       |                                                                                                                                                                                                   |
| 917    | DRAM PARITY : (BYTE 5)       |                                                                                                                                                                                                   |
| 918    | DRAM PARITY : (BYTE 6)       |                                                                                                                                                                                                   |
| 919    | DRAM PARITY : (BYTE 7)       |                                                                                                                                                                                                   |
| 920    | SERVO ALARM (1-4 AXIS)       | Servo alarm (first to fourth axis). A watchdog alarm condition occurred, or a RAM parity error occurred in the axis control card.<br>Replace the axis control card.                               |
| 921    | SERVO ALARM (5-8 AXIS)       | Servo alarm (fifth to eighth axis). A watchdog alarm condition occurred, or a RAM parity error occurred in the axis control card.<br>Replace the axis control card.                               |
| 926    | FSSB ALARM                   | FSSB alarm.<br>Replace the axis control card.                                                                                                                                                     |
| 930    | CPU INTERRUPT                | CPU error (abnormal interrupt).<br>The motherboard or CPU card may be faulty.                                                                                                                     |
| 935    | SRAM ECC ERROR               | An error occurred in RAM for part program storage.<br>Action:<br>Replace the master printed circuit board (SRAM module), perform all-clear operation, and set all parameter and other data again. |
| 950    | PMC SYSTEM ALARM             | An error occurred in the PMC.<br>The PMC control circuit on the motherboard may be faulty.                                                                                                        |
| 951    | PMC WATCH DOG ALARM          | An error occurred in the PMC.<br>(Watchdog alarm)<br>The motherboard may be faulty.                                                                                                               |
| 972    | NMI OCCURRED IN OTHER MODULE | An NMI occurred on a board other than the motherboard.<br>The option board may be faulty.                                                                                                         |
| 973    | NON MASK INTERRUPT           | An NMI occurred as a result of an unknown cause.                                                                                                                                                  |
| 974    | F-BUS ERROR                  | A bus error occurred on the FANUC bus.<br>The motherboard or option board may be faulty.                                                                                                          |
| 975    | BUS ERROR                    | A bus error occurred on the motherboard.<br>The motherboard may be faulty.                                                                                                                        |
| 976    | L-BUS ERROR                  | A bus error occurred on the local bus.<br>The motherboard may be faulty.                                                                                                                          |



## [Numbers]

7.2"/8.4" LCD-mounted Type CNC Control Unit, 452  
 8-digit Program Number, 152  
 9.5"/10.4" LCD-mounted Type CNC Control Unit, 452

---

## [A]

Absolute and Incremental Programming (G90, G91), 111  
 Actual Feedrate Display, 712  
 Address and Specifiable Value Range for Series 15 Tape Format, 350  
 Advance Preview Control (G08), 364  
 Alarm and Self-diagnosis Functions, 579  
 Alarm Display, 446\$580  
 Alarm History Display, 582  
 Alarm List, 847  
 Altering a Word, 657  
 Angular axis Control / Arbitrary Axis Control, 392  
 Arithmetic and Logic Operation, 305  
 Assembling, 549  
 Automatic Erase CNC Screen Display, 788  
 Automatic Inserting of Sequence Numbers, 686  
 Automatic Operation, 437\$512  
 Automatic Tool Offset (G36, G37), 286  
 Auxiliary Function, 133  
 Auxiliary Function (M Function), 134  
 Axis Control Function, 371

---

## [B]

B-axis Control (G100, G101, G102, G103, G110), 382  
 Background Editing, 677  
 Balance Cut (G68, G69), 412  
 Battery for Built-in Absolute Pulse Coders (DC6V), 817  
 Battery for Separate Absolute Pulse Coders (6 VDC), 816  
 Battery in the Panel *i* (3 VDC), 814  
 Branch and Repetition, 311

---

## [C]

Canceling Spindle Positioning, 125  
 Canned Cycle, 353  
 Canned Cycle (G90, G92, G94), 156  
 Canned Cycle for Drilling (G80-G89), 182  
 Canned Cycle for Drilling Cancel (G80), 192  
 Canned Drilling Cycle Formats, 356  
 Canned Grinding Cycle (for Grinding Machine), 194  
 Cautions on Various Kinds of Data, 8  
 Chamfering and Corner R, 198

Changing of Tool Offset Value (Programmable Data Input ) (G10), 285  
 Changing Workpiece Coordinate System, 102  
 Character-to-codes Correspondence Table, 846  
 Characters and Codes to be Used for the Pattern Data Input Function, 429  
 Check by Running the Machine, 439  
 Checked by Self-diagnostic Screen, 583  
 Chuck and Tailstock Barriers, 569  
 Circular Interpolation (G02, G03), 52  
 Circular Threading (G35, G36), 76  
 Clearing the Screen, 787  
 Command for Machine Operations – Miscellaneous Function, 25  
 Compensation Function, 219  
 Conditional Branch (IF Statement), 312  
 Conditions for Making a Tool Post Interference Check, 407  
 Connecting PCMCIA Card Attachment, 549  
 Constant Lead Threading (G32), 68  
 Constant Surface Speed Control (G96, G97), 116  
 Continuous Thread Cutting, 73  
 Controlled Axes, 31\$32  
 Conversational Programming with Graphic Function, 691  
 Coordinate Rotation (G68.1, G69.1), 289  
 Coordinate System, 97  
 Coordinate System on Part Drawing and Coordinate System Specified by CNC – Coordinate System, 17  
 Coordinate Value and Dimension, 110  
 Copying a Program between Two Paths, 419\$680  
 Copying an Entire Program, 668  
 Copying Part of a Program, 669  
 Corner Circular Interpolation Function (G39), 281  
 Correction in Chamfering and Corner Arcs, 268  
 Counter Input of Offset value, 753  
 Counting a Tool Life, 131  
 Creating Programs, 684  
 Creating Programs in Teach in Mode (Playback), 688  
 Creating Programs Using the MDI Panel, 685  
 Current Block Display Screen, 720  
 Current Position Display , 446  
 Custom Macro, 293  
 Cutting Feed, 88  
 Cutting Speed – Spindle Speed Function, 23  
 Cylindrical Interpolation (G07.1), 62

---

## [D]

Data Input/output, 586  
 Data Input/output on the All IO Screen, 614  
 Data Input/output Using a Memory Card, 639  
 Data Output, 449  
 Data Setting for the Tool Post Interference Check Function, 402  
 Decimal Point Programming, 113

Deleting a Block, 659  
 Deleting a Word, 658  
 Deleting All Programs, 665  
 Deleting Blocks, 659  
 Deleting Files, 611  
 Deleting More Than One Program by Specifying a Range, 666  
 Deleting Multiple Blocks, 660  
 Deleting One Program, 665  
 Deleting Programs, 665  
 Details of Functions, 339  
 Details of Tool Nose Radius Compensation, 242  
 Diameter and Radius Programming, 114  
 Direct Drawing Dimensions Programming, 202  
 Direct Input of Measured Workpiece Origin Offsets, 766  
 Direct Input of tool offset measured B, 751  
 Direct Input of Tool Offset Value, 749  
 Direction of Imaginary Tool Nose, 231  
 Display, 445  
 Display of Run Time and Parts Count, 714  
 Displaying a Program List for a Specified Group , 742  
 Displaying and Entering Setting Data, 759  
 Displaying and Setting Custom Macro Common Variables, 768  
 Displaying and Setting Data, 442  
 Displaying and Setting Parameters, 777  
 Displaying and Setting Pitch Error Compensation Data, 779  
 Displaying and Setting Run Time, Parts Count, and Time, 763  
 Displaying and Setting the Software Operator's Panel, 769  
 Displaying and Setting the Workpiece Origin Offset Value, 765  
 Displaying and Setting Tool Life Management Data, 771  
 Displaying Directory of Floppy Disk, 605  
 Displaying Memory Used and a List of Programs, 736  
 Displaying the B-axis Operation State, 734  
 Displaying the Directory, 606  
 Displaying the Pattern Menu, 421  
 Displaying the Program Number and Sequence Number, 782  
 Displaying the Program Number, Sequence Number, and Status, and Warning Messages for Data Setting or Input/Output Operation, 782  
 Displaying the Status and Warning for Data Setting or Input/Output Operation, 783  
 Distribution Processing Termination Monitoring Function for the High-speed Machining Command (G05), 363  
 DNC Operation, 542  
 DNC operation, 546  
 DNC Operation with Memory Card, 545  
 Dry Run, 557  
 Dwell (G04), 91

**[E]**

Editing a Part Program, 441  
 Editing of Custom Macros, 676  
 Editing Programs, 651  
 Emergency Stop, 563  
 End Face Peck Drilling Cycle (G74), 175  
 End Face Turning Cycle (G94), 161  
 Equal-lead Threading, 351  
 Erase CRT Screen Display, 787  
 Example of Making a Tool Post Interference Check, 410  
 Execution of Tool Post Interference Checking, 408  
 Explanation of the Keyboard, 456  
 Extended Part Program Editing Function, 667  
 External I/O Devices, 479  
 External Operator Message History Display, 785  
 External Output Commands, 333

**[F]**

FANUC Handy File, 481  
 Feed Functions, 84  
 Feed-feed Function, 15  
 Feedrate Override, 555  
 File Deletion, 591  
 File Search, 589  
 Files, 587  
 Finishing Cycle (G70), 172  
 Floating Reference Position Return (G30.1), 96  
 Front Boring Cycle (G85) / Side Boring Cycle (G89), 191  
 Front Drilling Cycle (G83) / Side Drilling Cycle (G87), 186  
 Front Face Rigid Tapping Cycle (G84) / Side Face Rigid Tapping Cycle (G88), 208  
 Front Tapping Cycle (G84) / Side Tapping Cycle (G88), 189  
 Function Keys, 459  
 Function Keys and Soft Keys, 458  
 Function to Simplify Programming, 155  
 Functions for High Speed Cutting, 360

**[G]**

G53, G28, G30, and G30.1 Commands in Tool-tip Radius Compensation Mode, 272  
 G53, G28, G30, and G30.1 Commands When Tool Position Offset is Applied, 225  
 General Flow of Operation of CNC Machine Tool, 6  
 General Precautions for Offset Operations, 271  
 General Screen Operations, 458  
 Graphic Display (See Section III-12), 448  
 Graphics Display, 790  
 Graphics Function, 789

**[H]**

Heading a Program, 655  
 Helical Interpolation (G02, G03), 57  
 Help Function, 796  
 High Speed Cycle Cutting, 361  
 How to Indicate Command Dimensions for Moving the Tool – Absolute, Incremental Commands, 20  
 How to Use Canned Cycles (G90, G92, G94), 164  
 How to View the Position Display Change without Running the Machine, 440  
 Hypothetical Axis Interpolation (G07), 66

**[I]**

Imaginary Tool Nose, 229  
 Inch/metric Conversion (G20, G21), 112  
 Incorrect Threaded Length, 836  
 Increment System, 35  
 Incremental Feed, 490  
 Input Command from MDI, 270  
 Inputting / Outputting Custom Macro Common Variables, 603  
 Inputting a Program, 592  
 Inputting and Outputting Floppy Files, 625  
 Inputting and Outputting Offset Data, 622  
 Inputting and Outputting Parameters, 620  
 Inputting and Outputting Parameters and Pitch Error Compensation Data, 599  
 Inputting and Outputting Programs, 616  
 Inputting Custom Macro Common Variables, 603  
 Inputting Offset Data, 597  
 Inputting Parameters, 599  
 Inputting Pitch Error Compensation Data, 601  
 Inserting a Word, 656  
 Inserting, Altering and Deleting a Word, 652  
 Interference Check, 262  
 Interpolation Functions, 42  
 Interruption Type Custom Macro, 337

**[J]**

Jog Feed, 488

**[K]**

Key Input and Input Buffer, 476

**[L]**

Limitation and Notes, 548  
 Limitations, 332

Linear Interpolation (G01), 51  
 List of Functions and Tape Format, 828  
 Local Coordinate System, 107

**[M]**

M Code Group Check Function, 136  
 Machine Coordinate System, 98  
 Machine Lock and Auxiliary Function Lock, 553  
 Macro Call, 316  
 Macro Call Using an M Code, 324  
 Macro Call Using G Code, 323  
 Macro Statements and NC Statements, 310  
 Manual Absolute On and Off, 494  
 Manual Handle Feed, 491  
 Manual Handle Interruption, 535  
 Manual Intervention and Return, 540  
 Manual Linear/circular Interpolation, 499  
 Manual Numeric Command, 504  
 Manual Operation, 434\$485  
 Manual Reference Position Return, 486  
 Maximum Strokes, 36  
 MDI Operation, 516  
 Memory Card Input/Output, 630  
 Memory Common to Tool Posts, 414  
 Memory Operation, 513  
 Memory Operation by Series 15 Tape Format, 349  
 Merging a Program, 671  
 Method of Replacing Battery, 807  
 Mirror Image, 538  
 Mirror Image for Double Turret (G68, G69), 201  
 Modal Call (G66), 321  
 Moving Part of a Program, 670  
 Multiple M Commands in a Single Block, 135  
 Multiple Repetitive Canned Turning Cycle, 354  
 Multiple Repetitive Cycle (G70–G76), 166  
 Multiple Thread Cutting Cycle (G76), 177  
 Multiple-thread Cutting, 74  
 Multistage Skip (G31), 81

**[N]**

Name of Axes, 34  
 Next Block Display Screen, 721  
 Nomographs, 835  
 Notes on Multiple Repetitive Cycle (G70–G76), 181  
 Notes on Reading this Manual, 8  
 Notes on Tool Nose Radius Compensation, 239

**[O]**

Offset, 222

Offset Data Input and Output, 597  
 Offset Number, 221  
 Offset Number and Offset Value, 232  
 Operating Monitor Display, 716  
 Operational Devices, 450  
 Operations, 546  
 Oscillation Direct Fixed-Dimension Grinding Cycle, 197  
 Oscillation Grinding Cycle (G73), 196  
 Outer Diameter / Internal Diameter Cutting Cycle (G90), 156  
 Outer Diameter / Internal Diameter Drilling Cycle (G75), 176  
 Outputting a Program, 595  
 Outputting a Program List for a Specified Group, 613  
 Outputting Custom Macro Common Variable, 604  
 Outputting Custom Macro Common Variables, 624  
 Outputting Offset Data, 598  
 Outputting Parameters, 600  
 Outputting Pitch Error Compensation Data, 602  
 Outputting Programs, 610  
 Overall Position Display, 709  
 Overcutting by Tool Nose Radius Compensation, 267  
 Overtravel, 564  
 Overview of Tool Nose Radius Compensation, 229

## [P]







Parameter, 548  
 Part Drawing and Tool Movement, 16  
 Parts Count Display, Run Time Display, 447  
 Password Function, 678  
 Pattern Data Display, 425  
 Pattern Data Input Function, 420  
 Pattern Repeating (G73), 171  
 Plane Selection, 109  
 Polar Coordinate Interpolation (G12.1, G13.1), 58  
 Polygonal Turning, 372  
 Position Display in the Relative Coordinate System, 706  
 Position Display in the Workpiece Coordinate System, 704  
 Positioning (G00), 43  
 Power Disconnection, 484  
 Power On/off, 482  
 Precautions to be Taken by Operator, 193  
 Preparatory Function (G Function), 37  
 Presetting the Workpiece Coordinate System, 711  
 Processing Macro Statements, 329  
 Program Check Screen, 722  
 Program Components other than Program Sections, 140  
 Program Configuration, 26\$138  
 Program Contents Display, 719  
 Program Display, 445

Program Input/output, 592  
 Program Number Search, 662  
 Program of Tool Life Data, 128  
 Program Restart, 520  
 Program Screen for MDI Operation, 725  
 Program Section Configuration, 143  
 Programmable Parameter Entry (G10), 346

## [R]

Radius Direction Error at Circle Cutting, 843  
 Range of Command Value, 832  
 Rapid Traverse, 87  
 Rapid Traverse Override, 556  
 Reading Files, 609  
 Recommended Memory Card, 551  
 Reference Position, 92  
 Reference Position (Machine-Specific Position), 16  
 Reference Position Return, 93  
 Registering Custom Macro Programs, 331  
 Repetition (While Statement), 313  
 Replacement of Words and Addresses, 674  
 Replacing Battery for LCD-mounted Type *i* Series, 808  
 Replacing the Battery for Stand-alone Type *i* Series, 811  
 Rigid Tapping, 207  
 Rotary Axis Control, 378  
 Rotary Axis Roll-over, 377

## [S]

Safety Functions, 562  
 Sample Program, 327  
 Scheduling Function, 528  
 Screen Displayed at Power-on, 483  
 Screen Hardcopy, 801  
 Screens Displayed by Function Key  , 785  
 Screens Displayed by Function Key  , 745  
 Screens Displayed by Function Key  , 703  
 Screens Displayed by Function Key  (in Memory Mode or MDI Mode), 718  
 Screens Displayed by Function Key  (in the EDIT Mode), 735  
 Screens Displayed by Function Key  , 776  
 Selecting a Workpiece Coordinate System, 101



Selection of Tool Used for Various Machining – Tool Function, 24  
 Sequence Number Comparison and Stop, 761  
 Sequence Number Search, 663  
 Setting a Workpiece Coordinate System, 99  
 Setting and Display of Interference Forbidden Areas for Tool Post Interference Checking, 406  
 Setting and Display Units, 451  
 Setting and Displaying B-axis Tool Compensation, 774  
 Setting and Displaying Data, 695  
 Setting and Displaying the Tool Offset Value, 746  
 Setting Input/Output-Related Parameters, 615  
 Setting the Floating Reference Position, 715  
 Setting the Workpiece Coordinate System Shifting Amount, 754  
 Simple Calculation of Incorrect Thread Length, 838  
 Simple Call (G65), 317  
 Simple Synchronization Control, 379  
 Single Block, 558  
 Skip Function (G31), 79  
 Soft Key Configuration, 478  
 Soft Keys, 460  
 Specification, 545  
 Specification Method, 338  
 Specification number, 549  
 Specifying a Tool Group in a Machining Program, 132  
 Specifying the Spindle Speed Value Directly (S5-digit Command), 116  
 Specifying the Spindle Speed with a Code, 116  
 Spindle Control in Two-path Control, 415  
 Spindle Orientation, 123  
 Spindle Positioning, 123  
 Spindle Positioning Function, 123  
 Spindle Speed Fluctuation Detection Function (G25, G26), 120  
 Spindle Speed Function, 115  
 Stamping the Machining Time, 726  
 Stand-alone Type 61 Full Key MDI Unit, 455  
 Stand-alone Type Small MDI Unit, 453  
 Stand-alone Type Standard MDI Unit, 454  
 Status when Turning Power on, when Clear and when Reset, 844  
 Stock Removal in Facing (G72), 170  
 Stock Removal in Turning (G71), 166  
 Stored Stroke Check, 565  
 Stroke Limit Check Prior to Performing Movement, 576  
 Subprogram (M98, M99), 149  
 Subprogram call (M198), 547  
 Subprogram Call Function (M198), 533  
 Subprogram Call Using an M Code, 325  
 Subprogram Calling, 352  
 Subprogram Calls Using a T Code, 326  
 Supplementary Explanation for Copying, Moving and Merging, 672  
 Synchronization Control, 381

Synchronization Control and Composite Control, 417  
 System Variables, 298

---

## [T]

T Code for Tool Offset, 221  
 Tape Code List, 825  
 Test Operation, 552  
 Testing a Program, 439  
 The Second Auxiliary Functions (B Codes), 137  
 Thread Cutting Cycle (G92), 158  
 Three-Dimensional Coordinate Conversion (G68, G69), 211  
 Tool Compensation and Number of Tool Compensation, 283  
 Tool Compensation Values, Number of Compensation Value, and Entering Values from the Program (G10), 283  
 Tool Figure and Tool Motion by Program, 29  
 Tool Function (T Function), 126  
 Tool Geometry Offset and Tool Wear Offset, 220  
 Tool Life Management, 128  
 Tool Movement Along Workpiece Parts Figure-interpolation, 12  
 Tool Movement by Programing – Automatic Operation, 436  
 Tool Movement in Offset Mode, 246  
 Tool Movement in Offset Mode Cancel, 259  
 Tool Movement in Start-up, 244  
 Tool Movement Range – Stroke, 30  
 Tool Offset, 220  
 Tool Path at Corner, 840  
 Tool Post Interface Check, 402  
 Tool Selection, 127\$221  
 Tool Withdrawal and Return (G10.6), 394  
 Torque Limit Skip (G31 P99), 82  
 Traverse Direct Fixed-dimension Grinding Cycle (G72), 195  
 Traverse Grinding Cycle (G71), 194  
 Turning on the Power, 482  
 Two-path Control Function, 397  
 Two-path Simultaneous Editing on the Program Screen, 739

---

## [U]

Unconditional Branch (GOTO Statement), 311

---

## [V]

Variable-lead Thread Cutting (G34), 72  
 Variables, 294

---

## [W]

Waiting for Tool Posts, 400  
 Warning Messages, 477

Word Search, 653

Work Position and Move Command, 234

Workpiece Coordinate System, 99

Workpiece Coordinate System Preset (G92.1), 104

Workpiece Coordinate System Shift, 106

---

**[Y]**

Y Axis Offset, 756

---

Revision Record

FANUC Series 16i/18i/160i/180i-TB OPERATOR'S MANUAL (B-63524EN)

| Edition | Date       | Contents | Edition | Date | Contents |
|---------|------------|----------|---------|------|----------|
| 01      | Jan., 2001 | _____    |         |      |          |
|         |            |          |         |      |          |
|         |            |          |         |      |          |
|         |            |          |         |      |          |



- *No part of this manual may be reproduced in any form.*
- *All specifications and designs are subject to change without notice.*